

REFERENCE:	Nova Bus Manuals
SECTION:	03: Windows
RS N°:	MQR 7621-2938
EFFECTIVE IN PROD.:	NA
TC RECALL N°:	2025-080
NHTSA RECALL N°:	25V-101

APPLICATION DEADLINES: N/A CLAIM
REFERENCE NUMBER: SR5785

SUBJECT:	Incorrect number of emergency exits according to FMVSS 217
JUSTIFICATION:	The affected vehicles may have been manufactured with an incorrect amount of emergency exits to meet the requirements of FMVSS 217. While exceeding the unobstructed opening surface required, the impacted vehicles do not provide at least 40% of the required area on each side of the bus. During an emergency, a non-compliance to FMVSS 217 may increase the time required to exit the bus, therefore increasing the risk of an injury.

LEVEL	DESCRIPTION	DIRECT CHARGES		TIME
		LABOUR	MATERIAL	
1	Replace the window with a window with an emergency exit.	Nova Bus	Nova Bus	5h30
2	-	-	-	-

MATERIAL REQUIRED PER VEHICLE

QTY	PART N°	REV.	DESCRIPTION
LEVEL 1			
1	N112838-13	-	MV78 Wdw ASSY - 6mm Lam 44% Gray -Set Screw Locks
1	N81626-1	-	DECAL EMERGENCY
1	N81626-2	-	DECAL EMERGENCY
1.5 ft	N44010	B	TAPE NEOPRENE 1" X 1/8THK (cut into 1 inch lengths)
56	N73848	F	Screw #10-16 X 1 3/8 TORX SS
1	N93837-82	-	WINDOW LEGACY 43% SLDR PO LAM
1	N8889151	-	Sash Stop (0000302C)
1	N8888127	-	Fastener for the Sash Stop (0000101F)

LEVEL 1 SHOP SUPPLIES***

QTY	PART N°	REV.	DESCRIPTION
400 ml	N32989	C	Sealant Butyl 757 (325 ml cartridge)

***WHEN ORDERING, PLEASE SPECIFY THE QUANTITY OF CONSUMABLES REQUIRED ACCORDING TO THE NUMBER OF BUSES TO BE REPAIRED.

Materials will be available within 98 days once your order has been placed.

To order, please contact novabus.parts@volvo.com

Or by phone for CANADA 1-800-771-6682, for USA 1-877-999-8808

Specify document number, quantity of parts required and shipping address.

DISPOSAL OF PARTS

REMOVED PARTS ARE:	DISCARDED *	RETAINED	* Dispose of the unused parts and the defective parts in accordance with local environmental standards in effect.
	Yes	-	

REVISION HISTORY

REV.	DATE	CHANGE DESCRIPTION	WRITTEN BY
NR	2026JA30	Initial release	André Pelletier

CLIENT	ORDER	ROAD NUMBER		VIN (2NVY/4RKY...)		QTY
		FROM	TO	FROM	TO	
University Of Colorado	L336					1

**WARNING**

FOLLOW YOUR INTERNAL SAFETY PROCEDURES.

PROCEDURE

- 1.1. Park the vehicle on an even surface with the transmission on neutral.
- 1.2. Apply the parking brake and set the master control switch to the **stop** position.

INSTRUCTIONS FOR THE FIRST WINDOW REPLACEMENT (N112838-13)

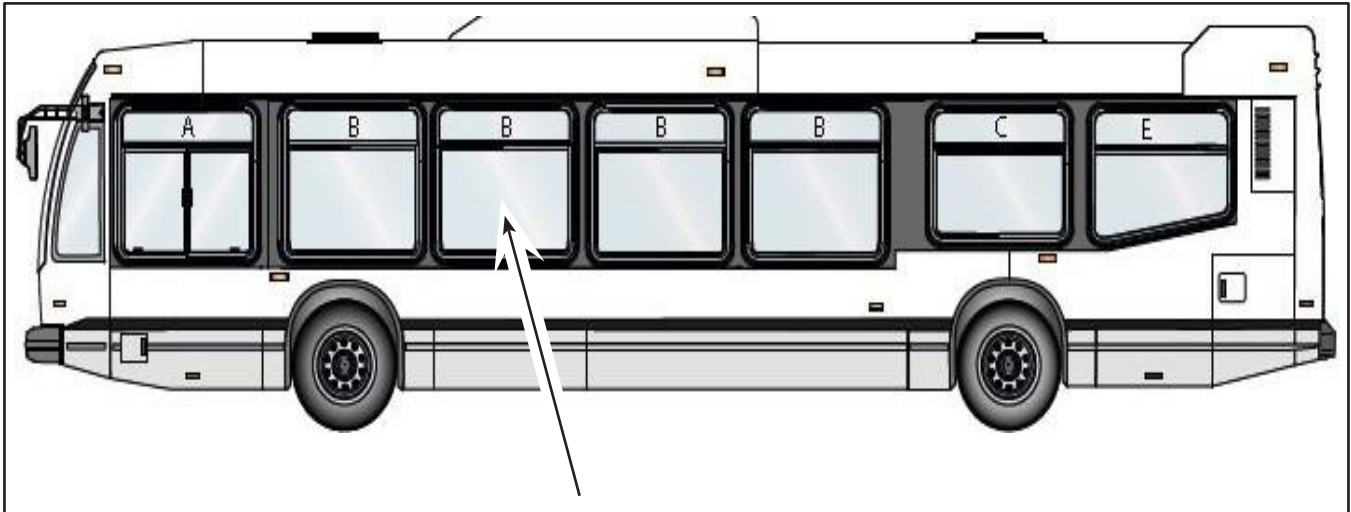

*Figure 1 - Location of the First Window to Be Replaced by a Window With an Emergency Exit N112838-13
(Image for Reference)*

- 1.3. On the front left side of the vehicle, remove the chime cord that is interfering with the window removal by removing the screws from the switch cover and then removing the mechanism from the wall. Retain the parts.

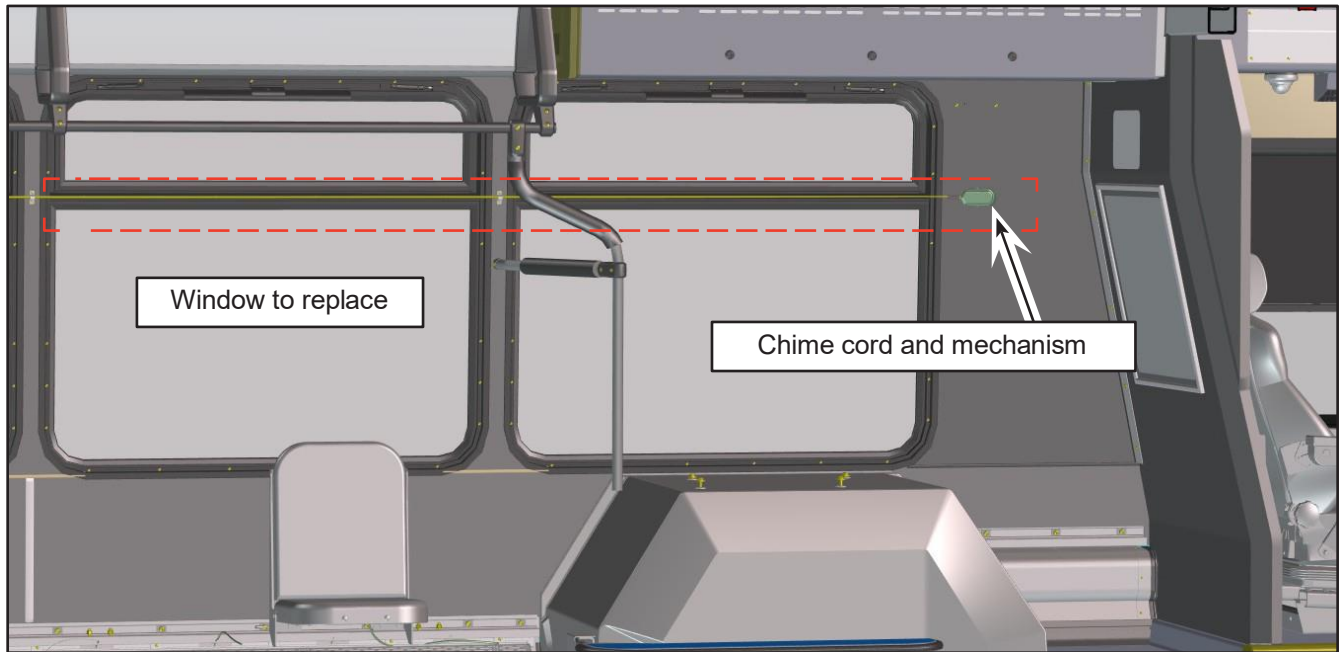

*Figure 2 - Remove the Chime Cord That is Preventing the Window From Being Removed
(Some Parts Omitted for Clarity, Your Configuration May Differ)*

**CAUTION**

Always wear thick gloves and safety glasses when handling glass. To avoid accidents when installing or removing windows, it is strongly recommended to work with at least one assistant. A suction cup window handler is recommended to make the job easier.

**NOTE**

The window must be installed from the outside of the vehicle. Once in place, a clamp ring is then screwed into the main frame from the inside.

For a video on the general window installation procedure, visit the supplier's website:

<https://arowglobal.com/literature-instructional-videos/>

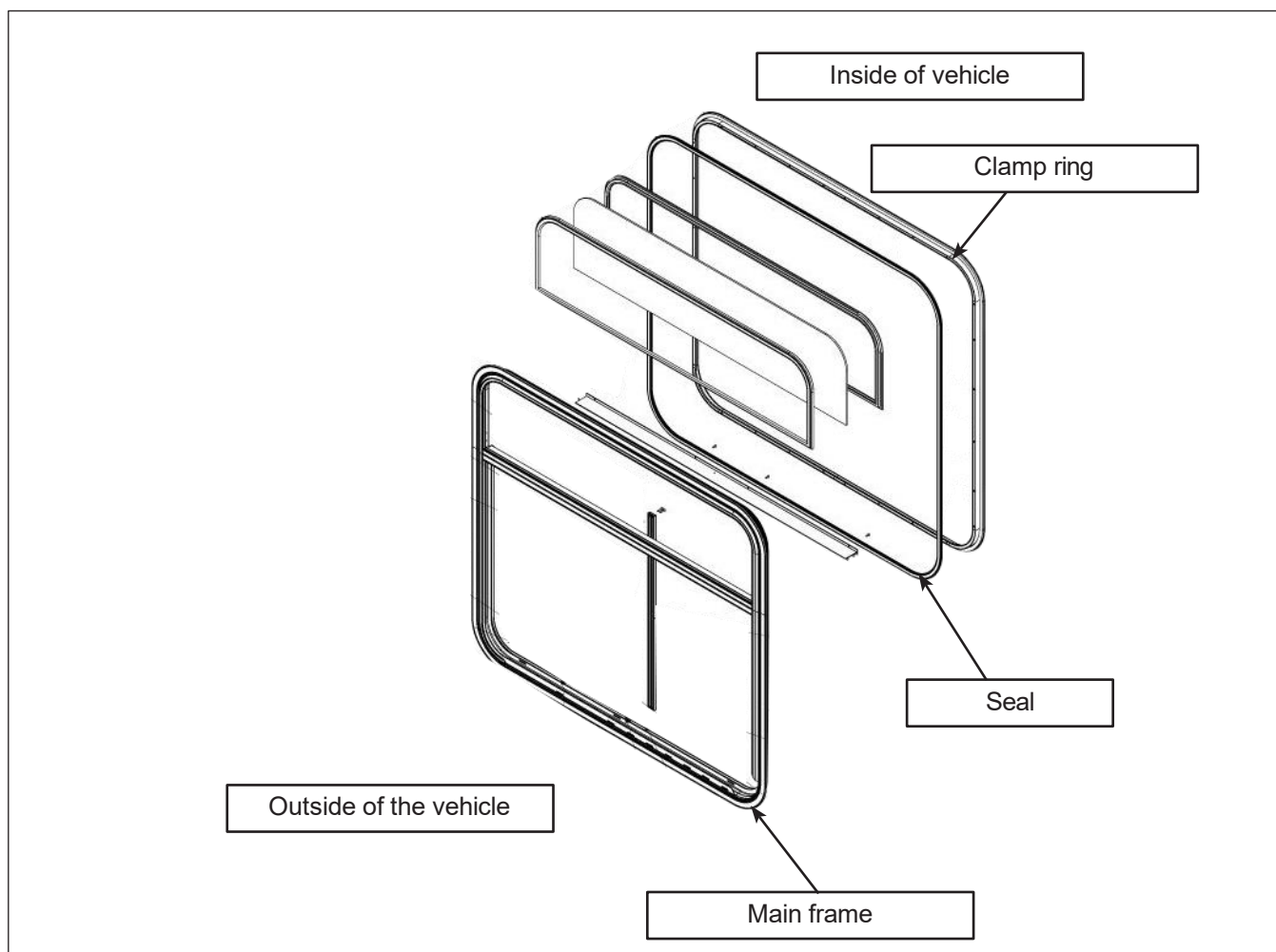

Figure 3 - Typical Example of Window Components

REMOVAL



CAUTION

Before removing and installing a window, **ensure that you have sufficient support to hold the windows from the outside.**

- 1.4. Remove and discard all screws securing the window assembly to the bus.
- 1.5. Remove the window as carefully as possible.

INSTALLATION

- 1.6. Place the new window on a dolly or suitable support, with the clamp ring facing upwards.
- 1.7. Ensure that the contact surfaces inside and outside the vehicle are clean and free of obstructions.
- 1.8. Seal all vertical joints between two exterior body panels with a 0.25 in bead of N32989 butyl sealant and also apply a bead around the entire window opening; see the following figure.

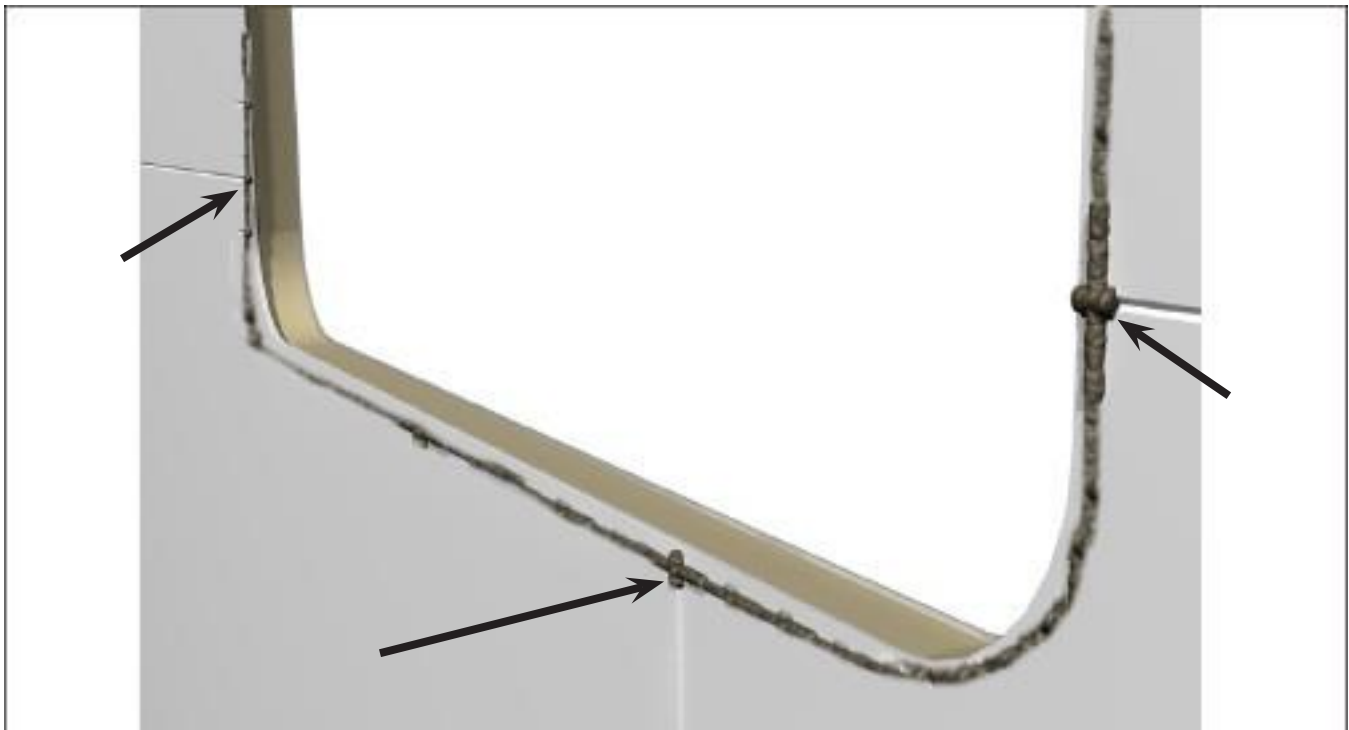

Figure 4 - Apply Butyl to the Body Seams and Around the Opening

- 1.9. Prepare the window for installation by removing the white foam blocks from the frame.



Figure 5 - Dispose of the Foam Protections

- 1.10. Then remove the clamp ring and check that the window seal is securely in place.



Figure 6 - Verify the Seal is at the Right Place

1.11. With the help of an assistant, place the window in the structure opening by resting the bottom of the window on the structure and tilting the top of the window against the bus body.

When positioning the window, be careful not to let the seal touch the edge of the structure opening. This could displace the seal and cause water leaks. See the following figure.

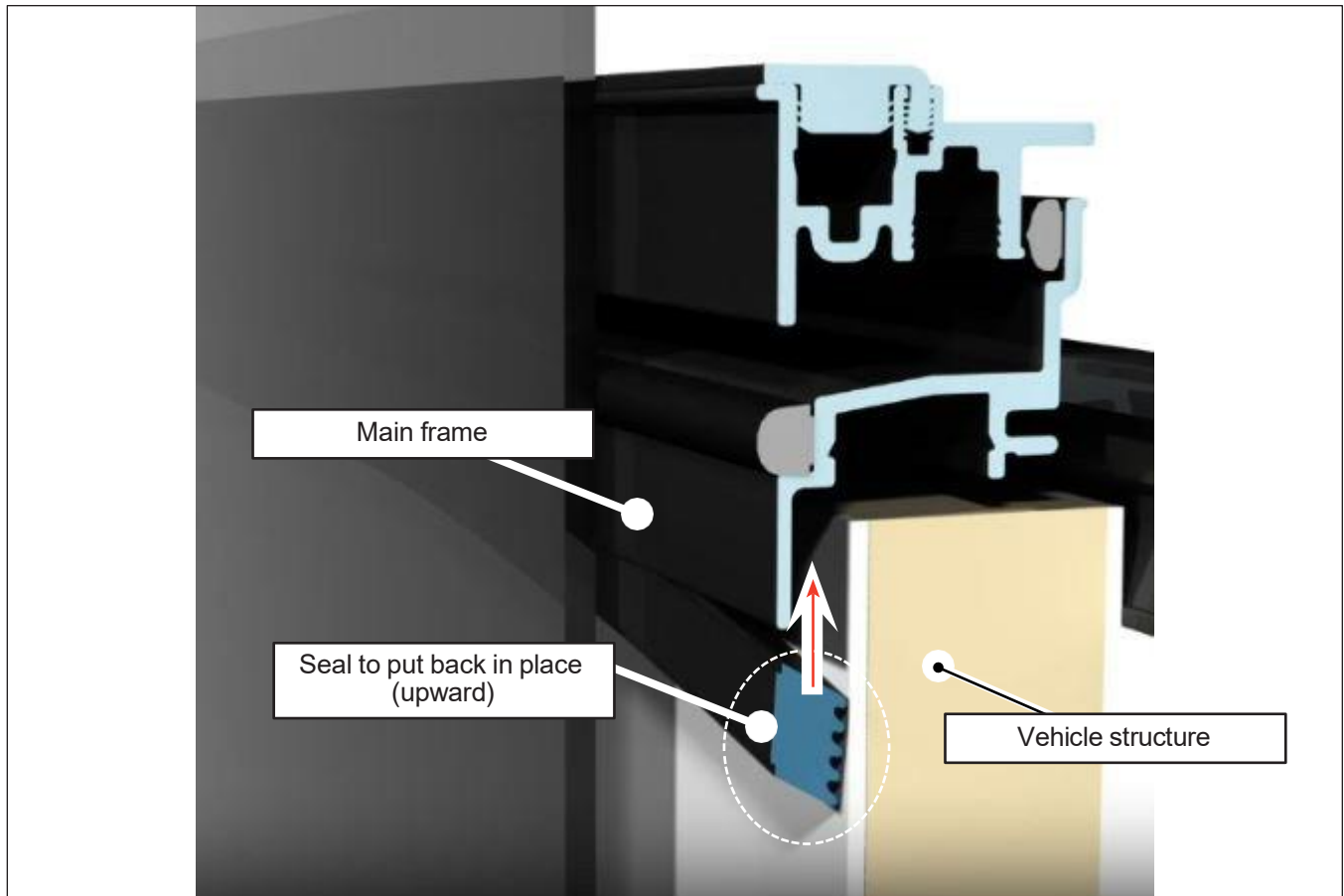

Figure 7 - Put the Seal Back in Place, if Required

- 1.12. Position the window in the center of the opening, adding N44010 shims (to be cut from the material provided) under the window support cushions from inside the bus, if necessary.

**CAUTION**

When positioning the window, do not shim or apply leverage to any part of the frame except at the support block locations indicated in green in the following figure or within 6 inches of the frame corners.

The maximum allowable distance between the window frame and the upper structural tube is 3/16 in. Shim the support pads as needed. See the following figure.

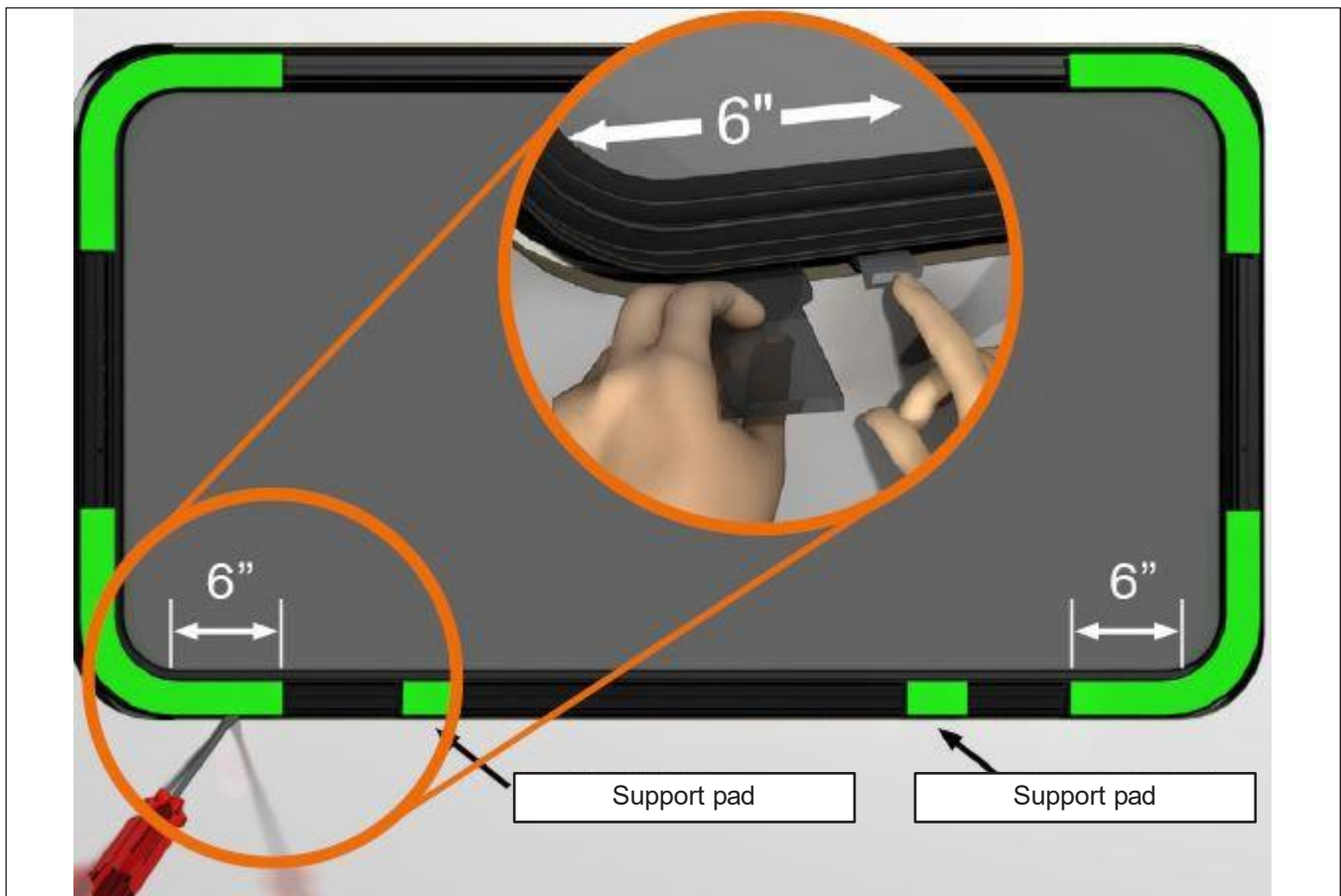

Figure 8 - Use a Lever or Install Shims Only in the Areas Indicated in Green

**NOTE**

Use a low-speed drill for initial screw installation (approximately 100 rpm).

Before installing each screw, lubricate it with Delo Starplex N24412 lubricant or equivalent.

- 1.13. Partially install the clamp ring using 6 screws. It is recommended to install the two bottom corners first, then the two top corners and the top center, on each side of the joint. Do not fully tighten the screws, as the window must be secure while still allowing for vertical and horizontal alignment adjustments. See the following figure for the installation of the first 6 screws.

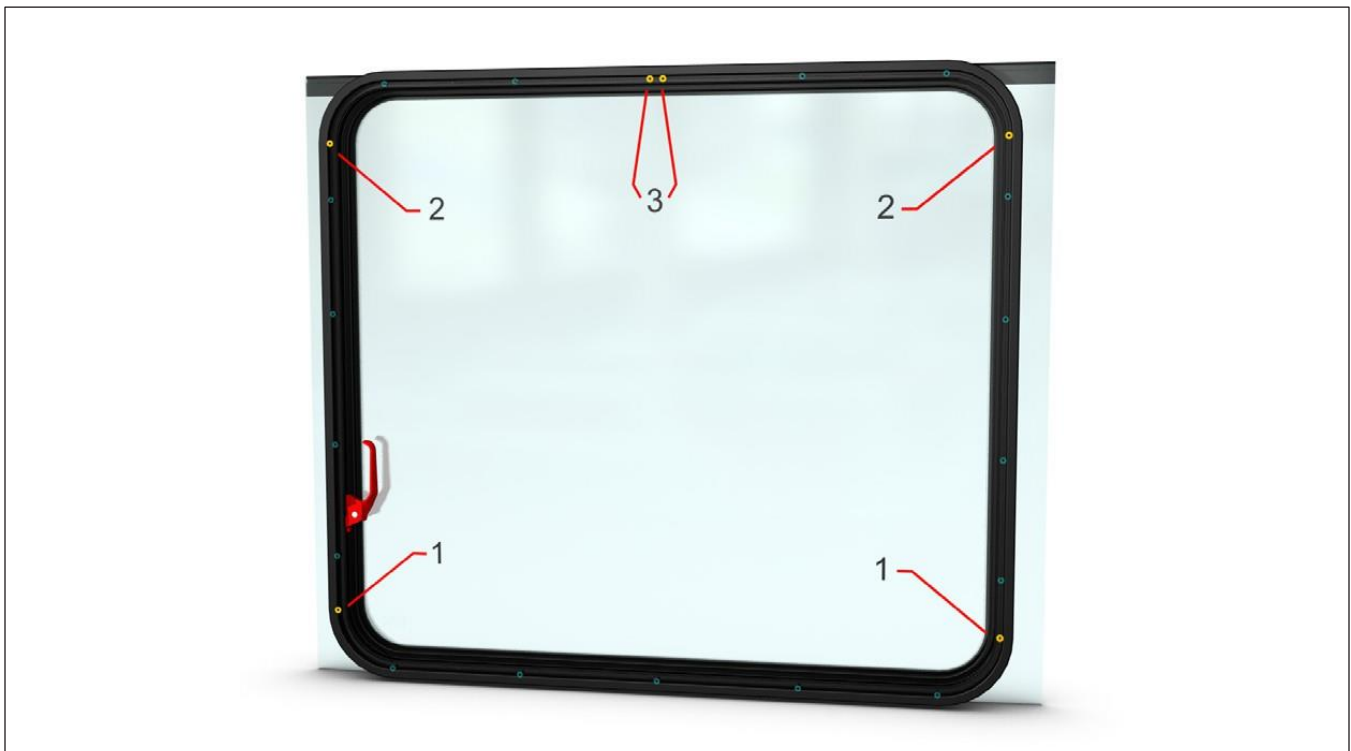

Figure 9 - Location of the 6 Bolts to be Installed Partially

- 1.14. Once horizontal and vertical alignment are complete, finish the clamp ring installation by tightening the remaining screws to 20 in-lb.

**NOTE**

Low speed drill to be used for initial screw installation (approximately 100 rpm).

- 1.15. Once all screws are installed, tighten them securely to 45 in-lb starting at the top joint and alternating on each side of the joint. See the following figure for the tightening sequence.

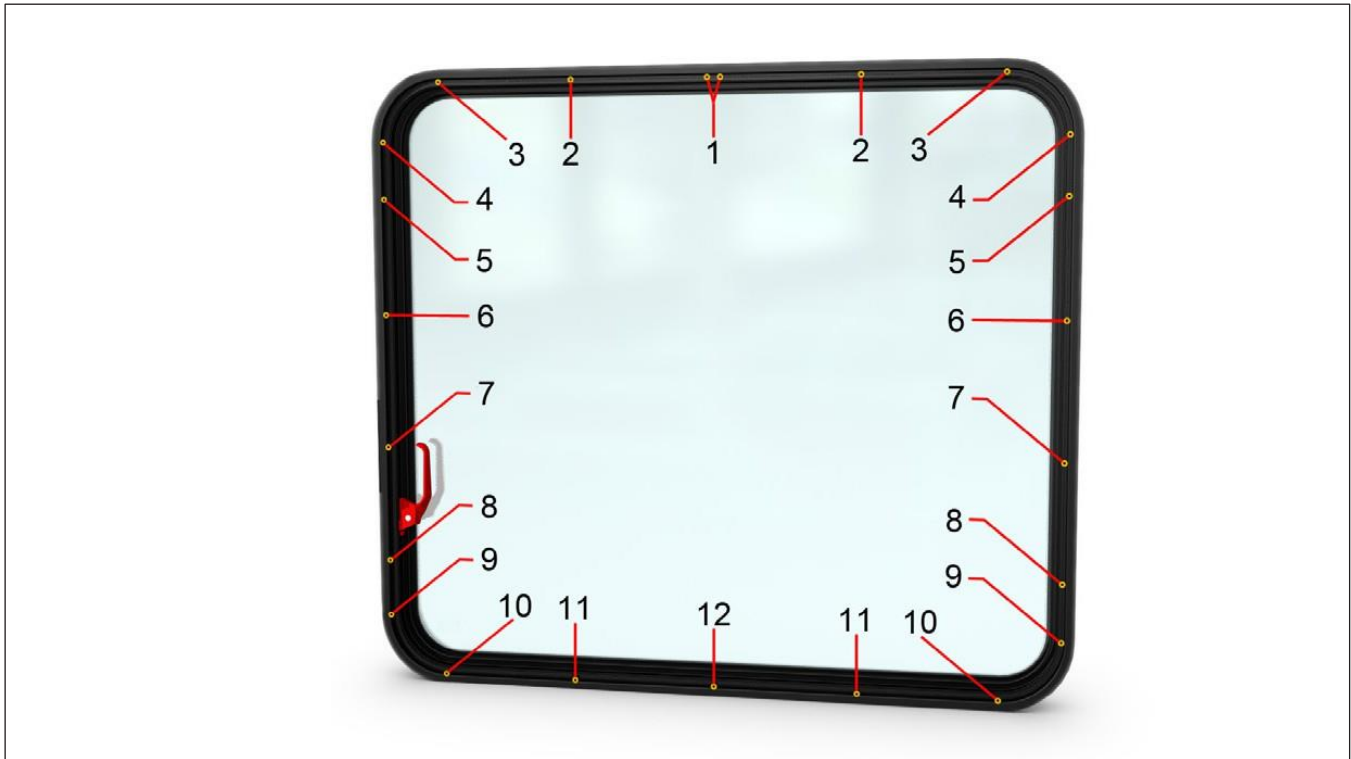

Figure 10 - Screws Torque Sequence

- 1.16. The tightening torque should be rechecked to ensure that no screws have been missed and/or that none have loosened after tightening adjacent screws.
- 1.17. As the window seal compresses, the tightening torque set during installation decreases. For optimal window seal performance, the anchor ring screws must have a minimum average tightening torque of 20 in-lb.
- 1.18. Once installation is complete, operate the emergency exit handle and open the window to an angle of approximately 60°. Release the window suddenly so that it closes and locks itself. Verify that the window is properly locked.

INSTALL THE STICKER

- 1.19. To install the sticker inside the vehicle, wash and degrease the window. Install the sticker next to the emergency exit handle, center it with the handle and at 5/8 in (17 mm) from it.

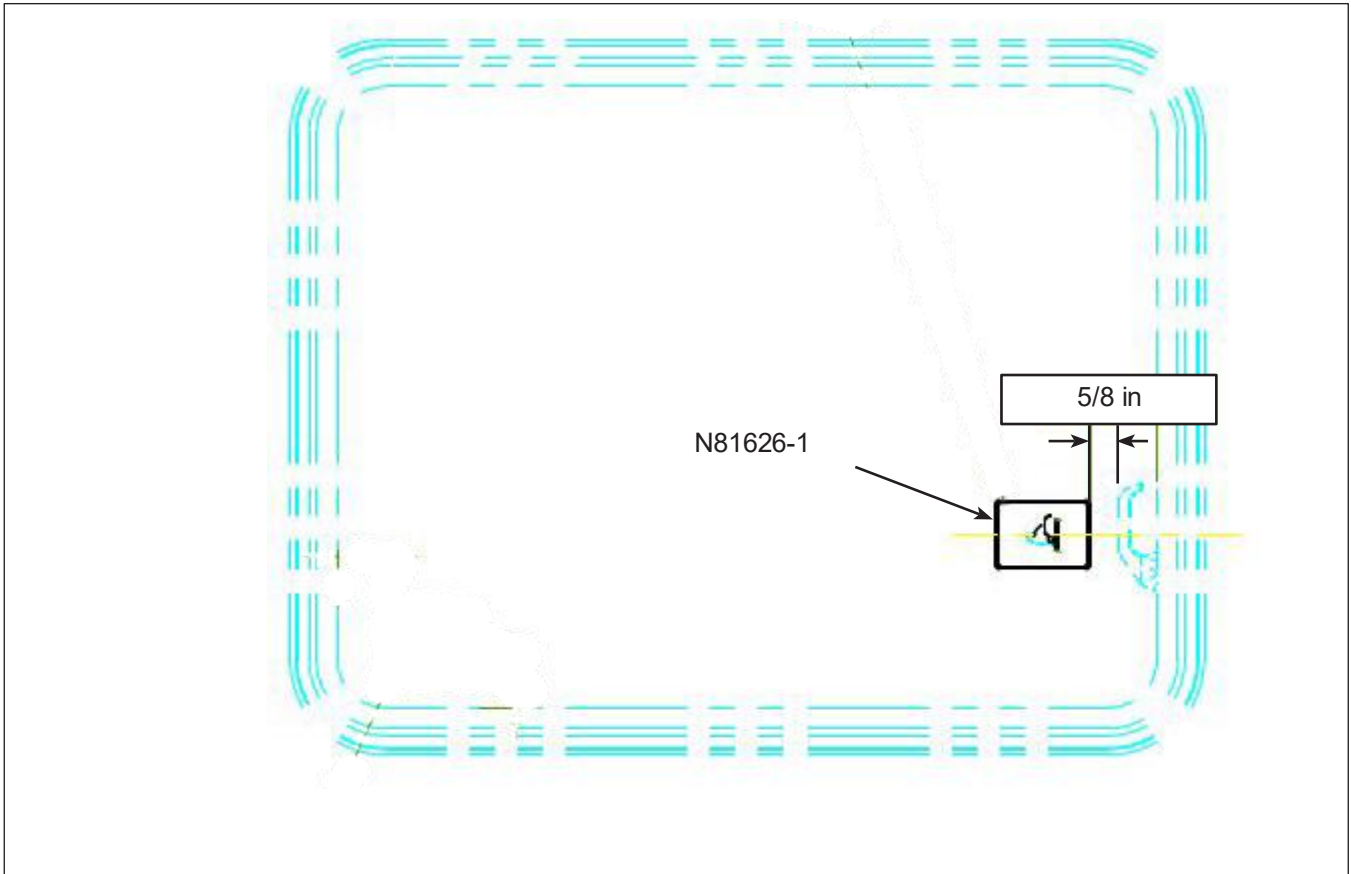

Figure 11 - Install the Sticker

- 1.20. Reinstall the chime cord as originally installed and check its operation.

INSTRUCTIONS FOR THE SECOND WINDOW REPLACEMENT (N93837-82)



Figure 12 - Location of the Second Window to Replace by N93837-82

- 1.21. On the rear right side of the vehicle, remove the chime cord that is interfering with the window removal by removing the screws from the switch cover and then removing the mechanism from the wall. Retain the parts. Your configuration may differ.

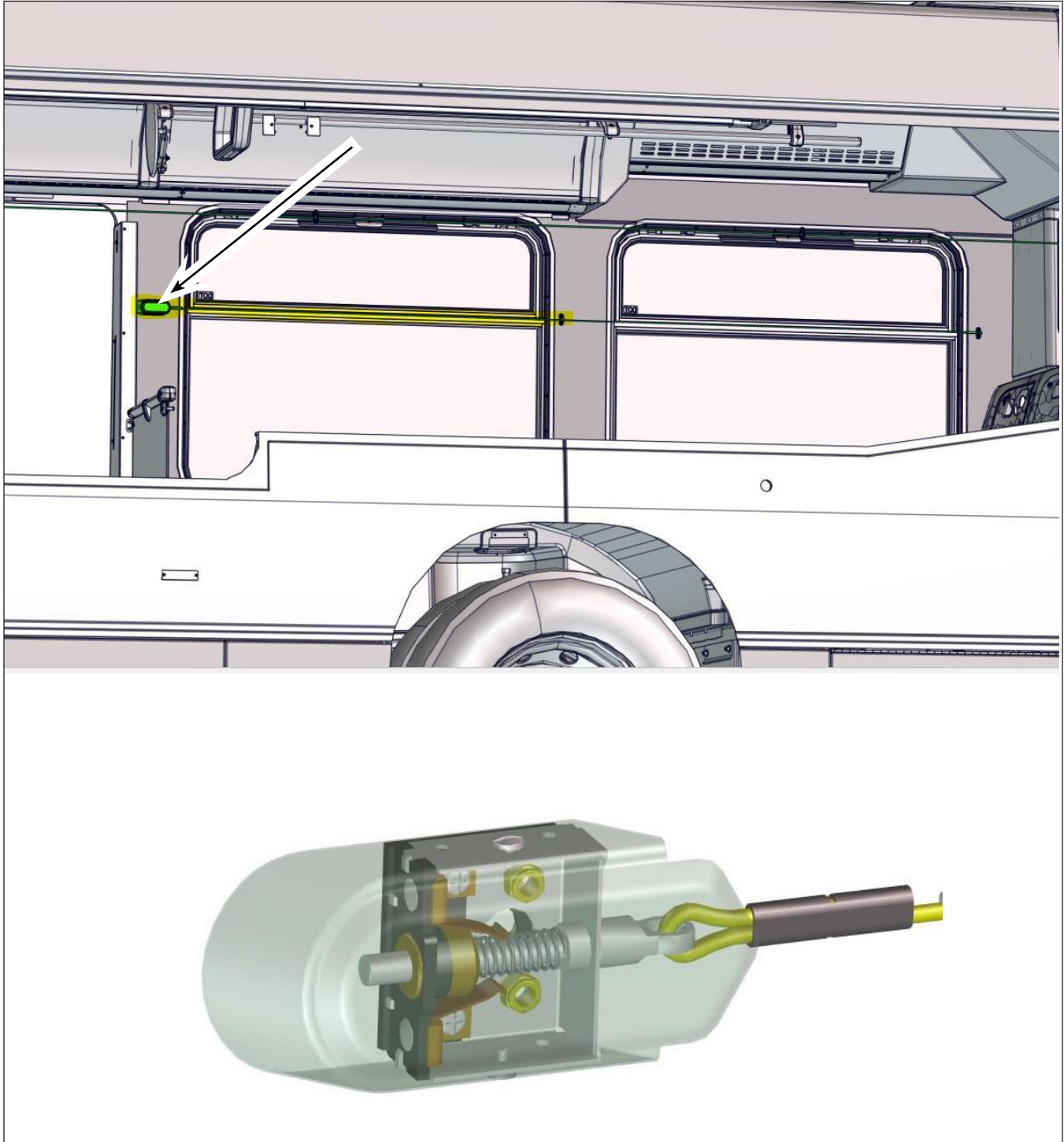

Figure 13 - Remove the Chime Cord (Your Configuration May Differ)

**CAUTION**

Always wear thick gloves and safety glasses when handling glass. To avoid accidents when installing or removing windows, it is strongly recommended to work with at least one assistant. A suction cup window handler is recommended to make the job easier.

**NOTE**

The window must be installed from the outside of the vehicle. Once in place, a clamp ring is then screwed into the main frame from the inside.

For a video on the general window installation procedure, visit the supplier's website:

<https://arowglobal.com/literature-instructional-videos/>

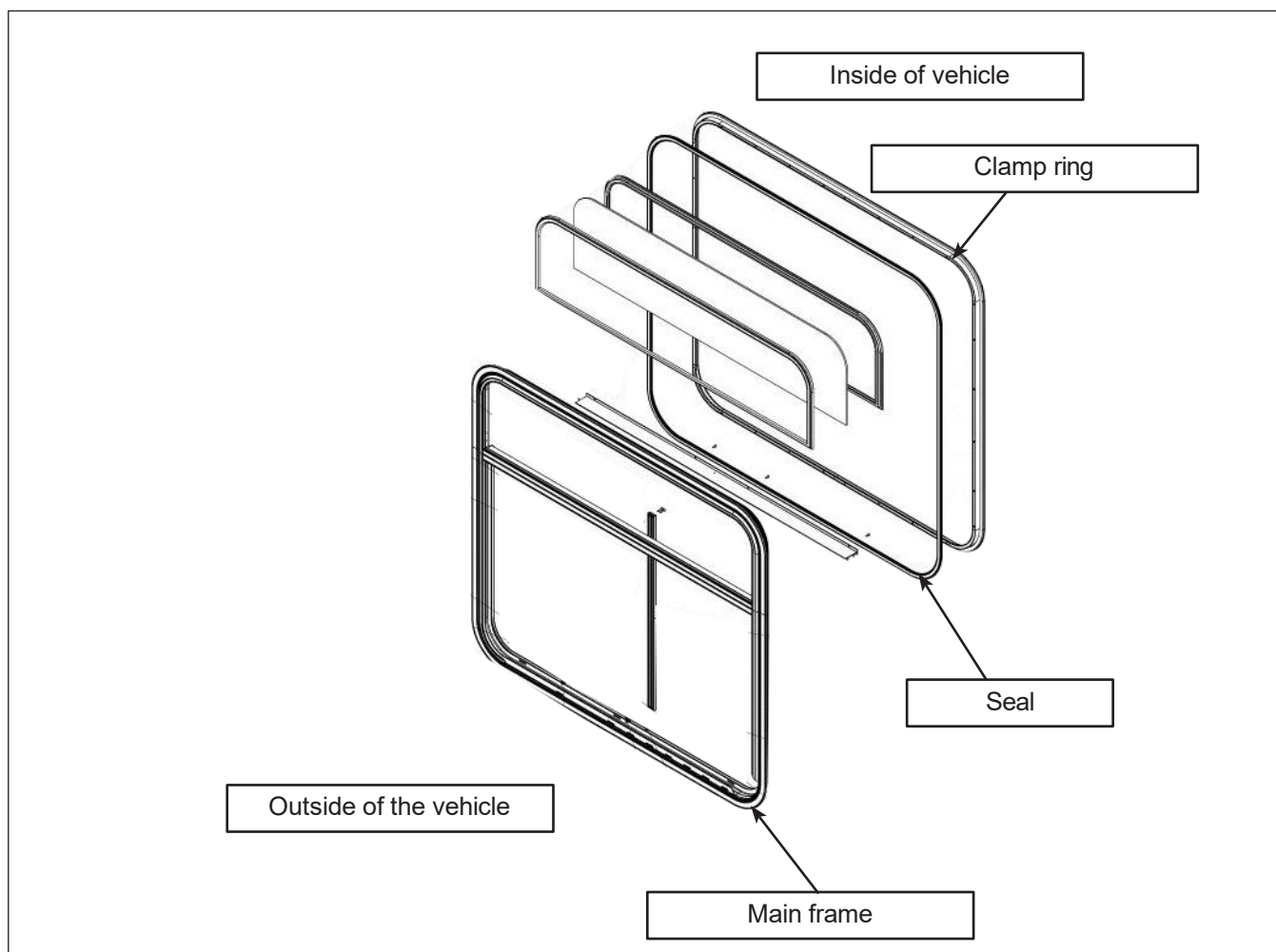

Figure 14 - Typical Example of Window Components

REMOVAL



CAUTION

Before removing and installing a window, **ensure that you have sufficient support to hold the windows from the outside.**

- 1.22. Remove and discard all screws securing the window assembly to the bus.
- 1.23. Remove the window as carefully as possible.

INSTALLATION

- 1.24. Place the new window on a dolly or suitable support, with the clamp ring facing upwards.
- 1.25. Ensure that the contact surfaces inside and outside the vehicle are clean and free of obstructions.
- 1.26. Prepare the window for installation by removing the white foam blocks from the frame.



Figure 15 - Dispose of the Foam Protections

1.27. Then remove the clamp ring and check that the window seal is securely in place.



Figure 16 - Verify the Seal is at the Right Place

- 1.28. Cut the tip of the butyl cartridges at the 1/4" mark. All butyl beads should have a diameter between 3/16" and 1/4" (approximately the size of a pencil). - The butyl applied to the window sealant should be centered on it.
- 1.29. Seal as close as possible to the edge of the window all joints between 2 exterior body panels with a 0.25 in bead of N32989 butyl sealant. See the following figure.

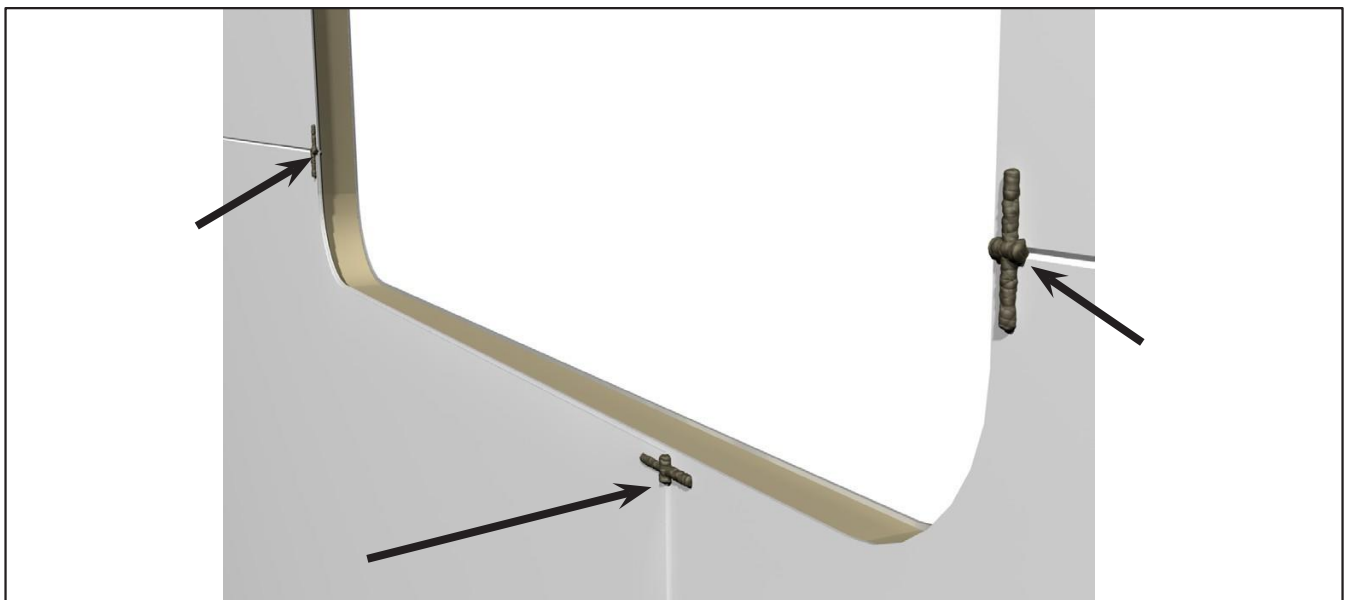

Figure 17 - Apply Butyl to the Body Seams

1.30. Apply butyl to the window seal, centered on it, only in the areas indicated in green on the following figure.

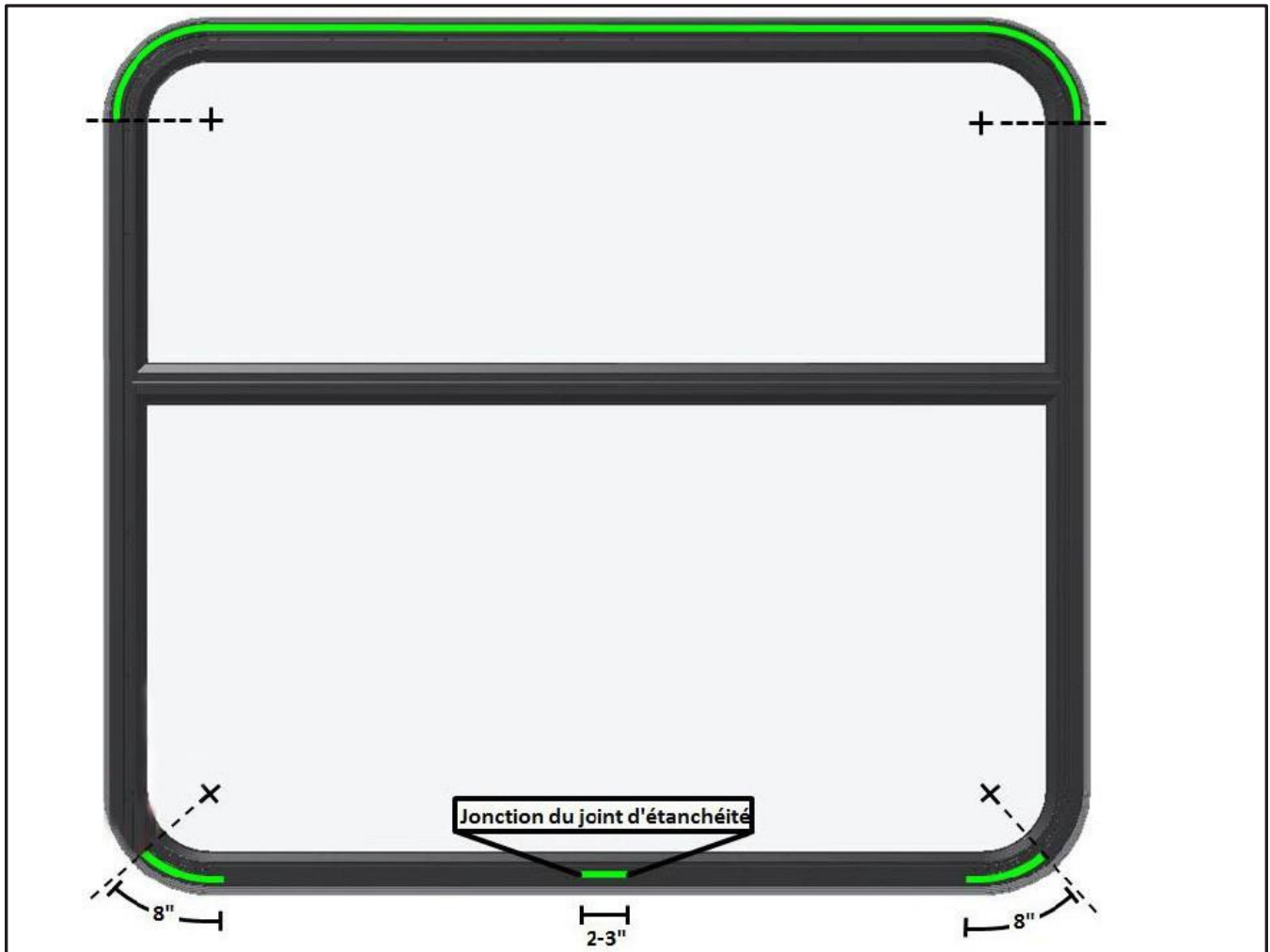

Figure 18 - Apply Butyl to the Body Seams

1.31. With the help of an assistant, place the window in the structure opening by resting the bottom of the window on the structure and tilting the top of the window against the bus body.

When positioning the window, be careful not to let the seal touch the edge of the structure opening. This could displace the seal and cause water leaks. See the following figure.

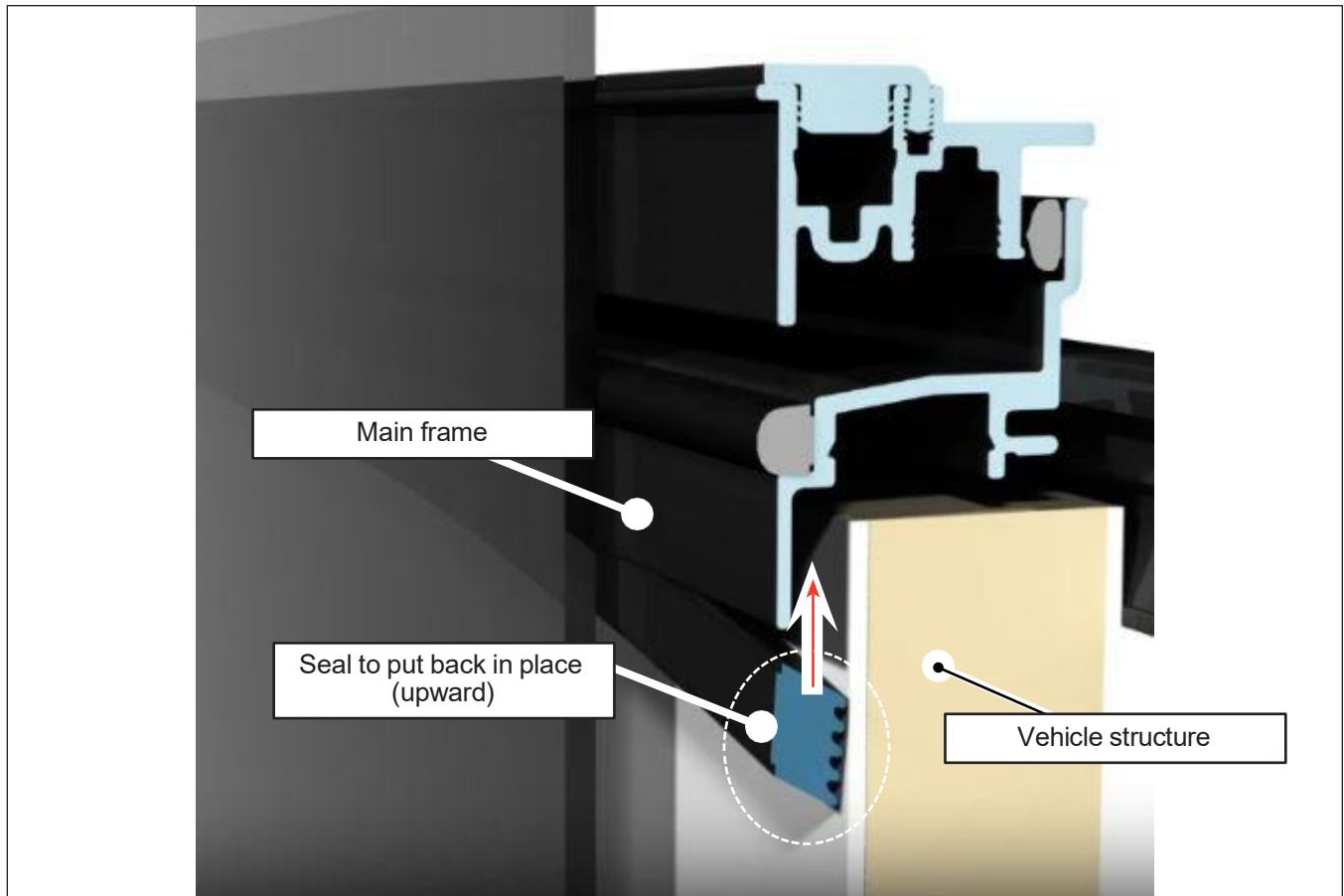

Figure 19 - Put the Seal Back in Place if Required

- 1.32. Position the window in the center of the opening, adding N44010 shims (to be cut from the material provided) under the window support cushions from inside the bus, if necessary.

**CAUTION**

When positioning the window, do not shim or apply leverage to any part of the frame except at the support block locations indicated in green in the following figure or within 6 inches of the frame corners.

The maximum allowable distance between the window frame and the upper structural tube is 3/16 in. Shim the support pads as needed. See the following figure.

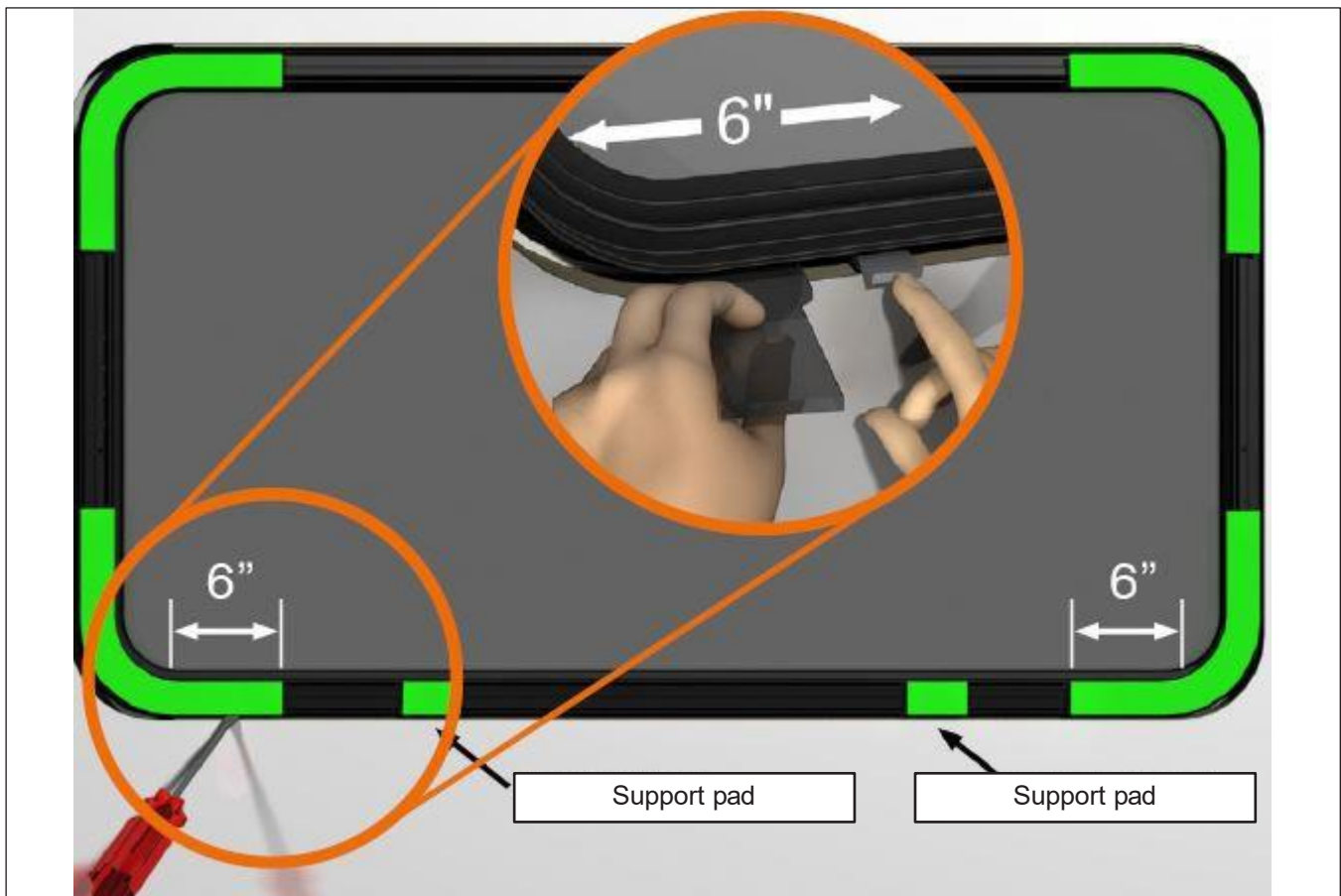

Figure 20 - Use a Lever or Install Shims Only in the Areas Indicated in Green

**NOTE**

Use a low-speed drill for initial screw installation (approximately 100 rpm).

Before installing each screw, lubricate it with Delo Starplex N24412 lubricant or equivalent.

- 1.33. Partially install the clamp ring using 6 screws. It is recommended to install the two bottom corners first, then the two top corners and the top center, on each side of the joint. Do not fully tighten the screws, as the window must be secure while still allowing for vertical and horizontal alignment adjustments. See the following figure for the installation of the first 6 screws.

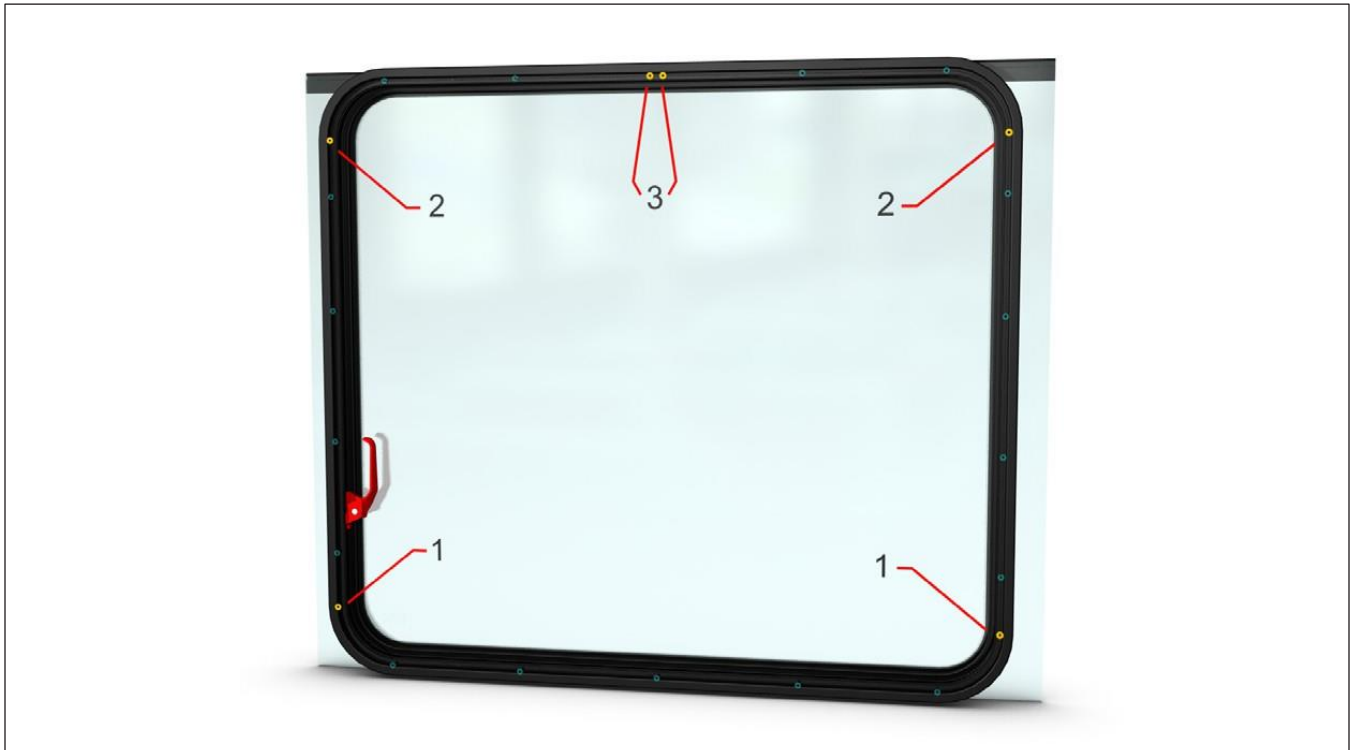

Figure 21 - Location of the 6 Bolts to be Installed Partially

- 1.34. Once horizontal and vertical alignment are complete, finish the clamp ring installation by tightening the remaining screws to 20 in-lb.

**NOTE**

Low speed drill to be used for initial screw installation (approximately 100 rpm).

- 1.35. Once all screws are installed, tighten them securely to 45 in-lb starting at the top joint and alternating on each side of the joint. See the following figure for the tightening sequence.

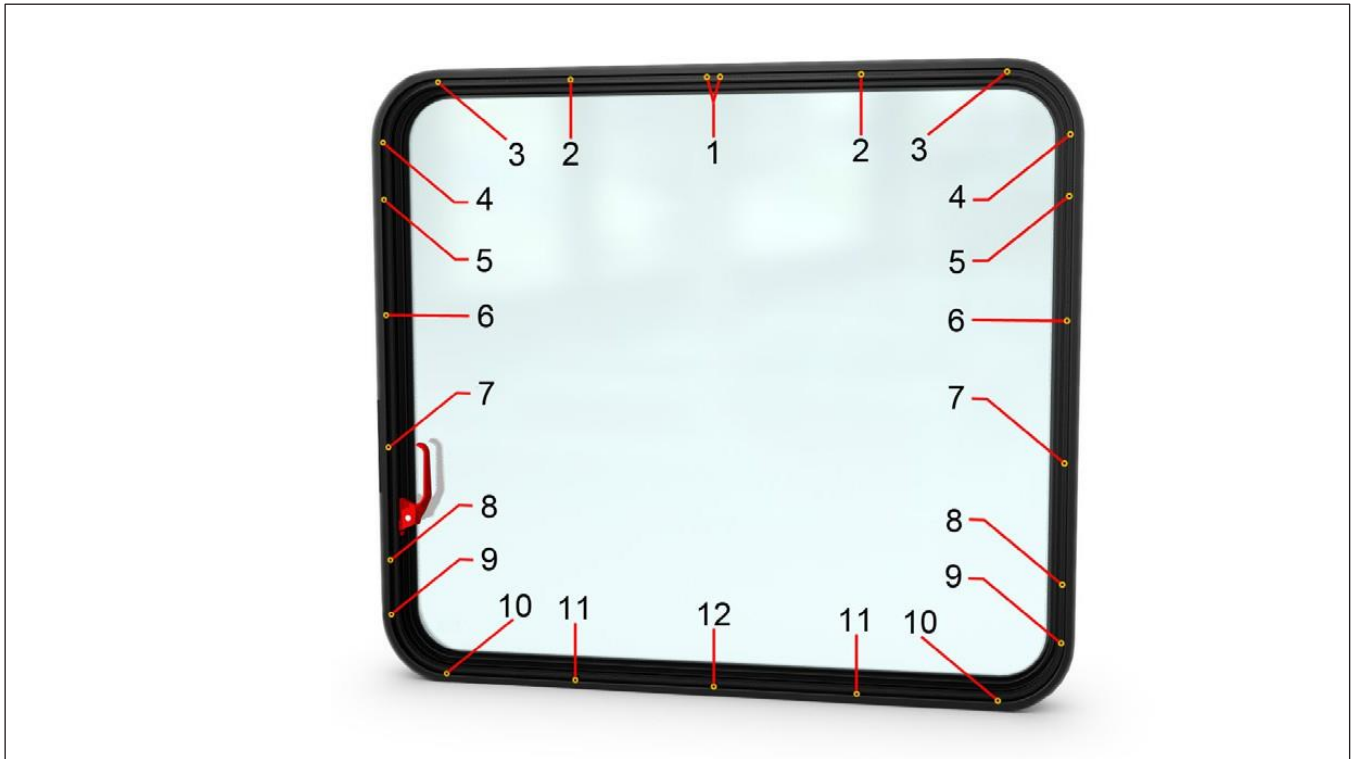

Figure 22 - Screws Torque Sequence

- 1.36. The tightening torque should be rechecked to ensure that no screws have been missed and/or that none have loosened after tightening adjacent screws.
- 1.37. As the window seal compresses, the tightening torque set during installation decreases. For optimal window seal performance, the anchor ring screws must have a minimum average tightening torque of 20 in-lb.
- 1.38. Once installation is complete, operate the emergency exit handle and open the window to an angle of approximately 60°. Release the window suddenly so that it closes and locks itself. Verify that the window is properly locked.

INSTALL THE STICKER

- 1.39. To install the sticker inside the vehicle, wash and degrease the window. Install the sticker next to the emergency exit handle, center it with the handle and at 5/8 in from it.

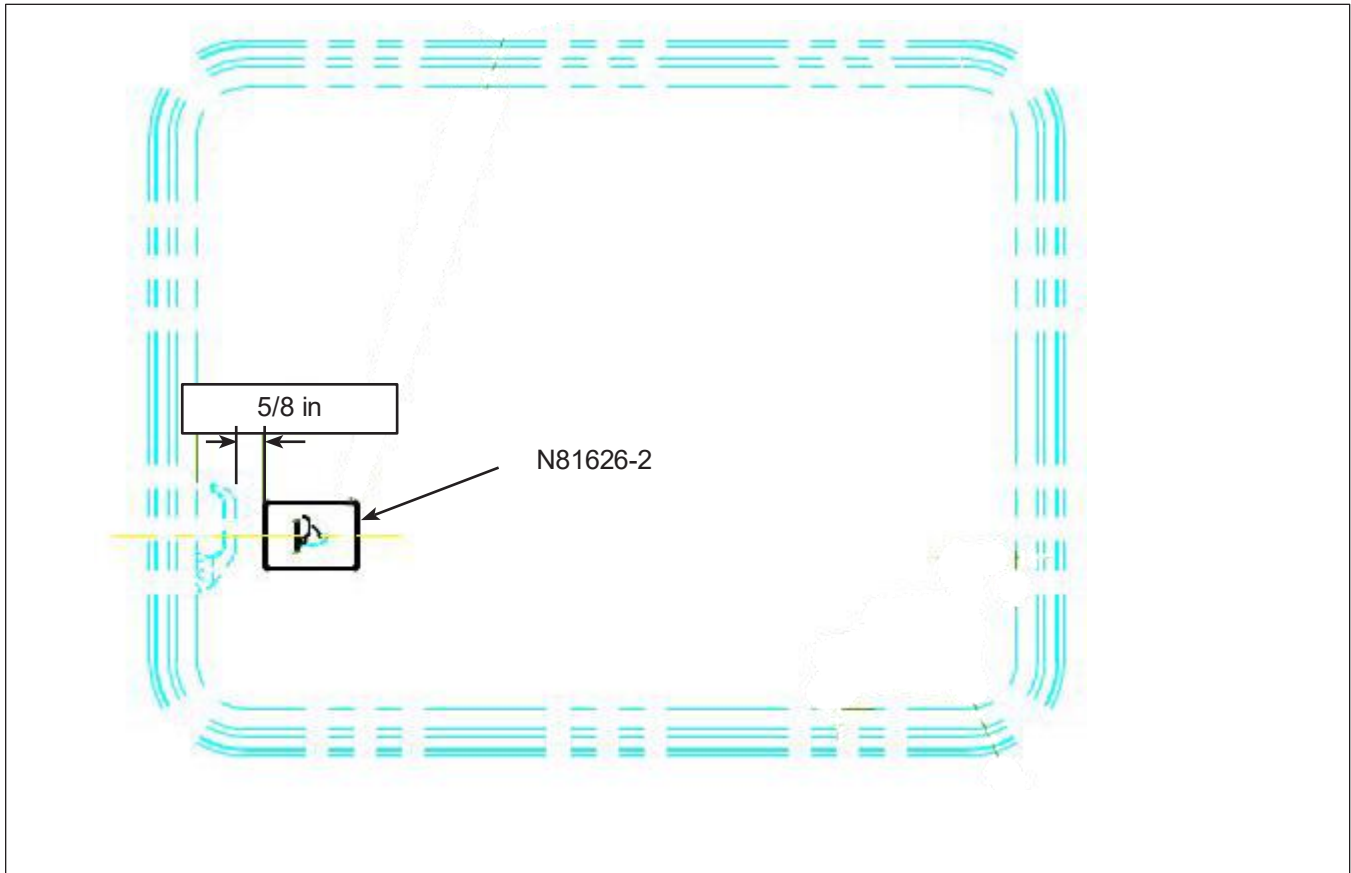

Figure 23 - Install the Sticker

- 1.40. Reinstall the chime cord as originally installed and check its operation.

1.41. A sash stop, N8889151 with a screw N8888127, must be installed so that the emergency exit sliding window opens only a maximum of 5 1/4 inches.

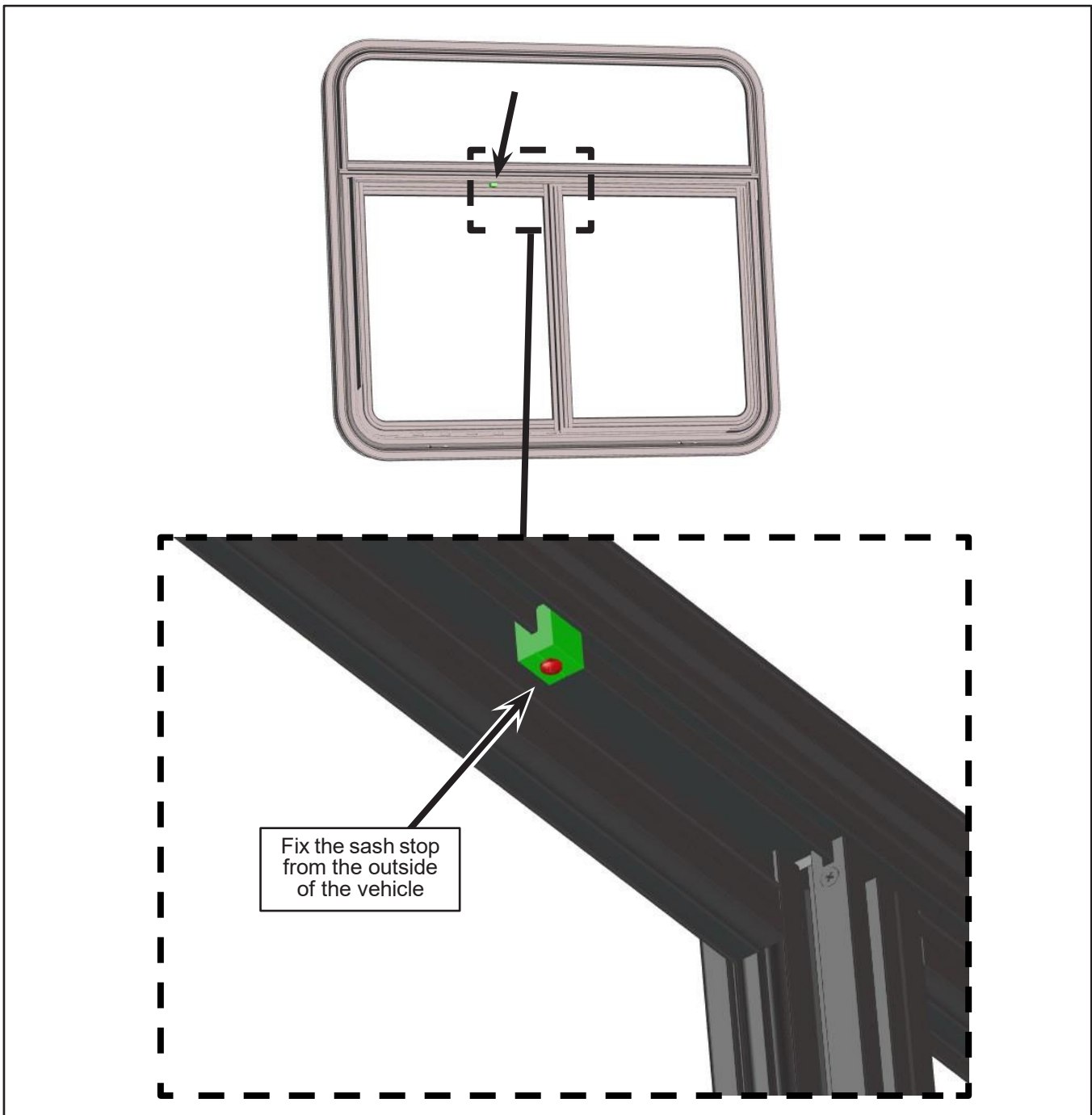

Figure 24 - Install a Sash Stop

1.42. The vehicle may be returned to service.

