

TECHNICAL INSTRUCTIONS
FOR
SAFETY RECALL 25LA03
INCREASED RISK OF INJURY DUE TO SEAT BELT DAMAGE
CERTAIN 2024-25MY RX and 2025MY NX

The repair quality of covered vehicles is extremely important to Lexus. All dealership technicians performing this repair are required to successfully complete the most current version of the E-Learning course "Safety Recall and Service Campaign Essentials". To ensure that all vehicles have the repair performed correctly; technicians performing this repair are required to currently have completed the following course:

- LIC206A - Electrical Repair 1

It is the dealership's responsibility to select technicians that have completed the above courses to perform this repair. Carefully review your resources, the technician skill level, and ability before assigning technicians to this repair. It is important to consider technician days off and vacation schedules to ensure there are properly trained technicians available to perform this repair at all times.

I. OPERATION FLOW CHART

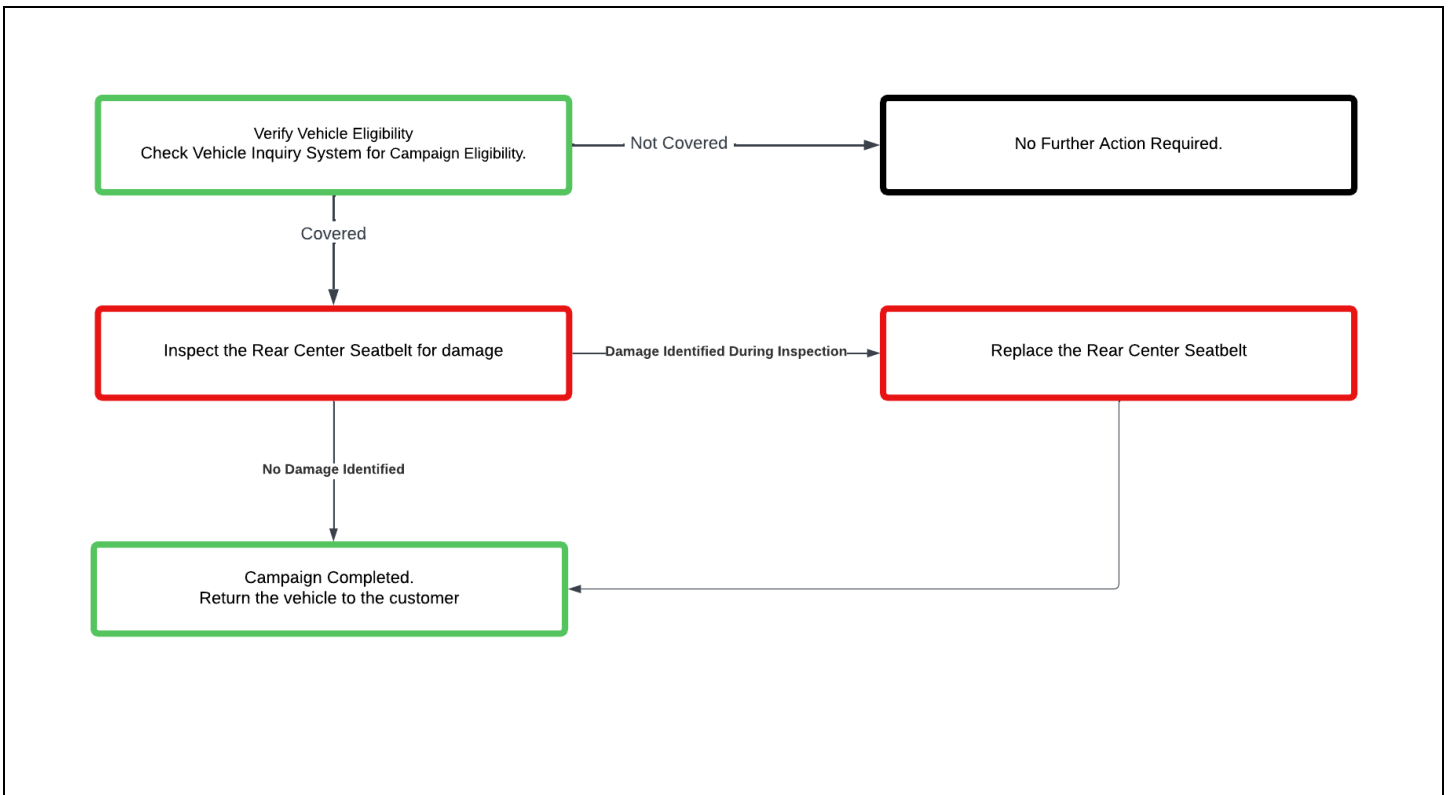

II. IDENTIFICATION OF AFFECTED VEHICLES

1. CHECK VEHICLE FOR CAMPAIGN ELIGIBILITY

- a. Compare the vehicle's VIN to the VIN listed on the Repair Order to ensure they match.
- b. Check the TIS Vehicle Inquiry System or Service Lane to verify this vehicle is eligible for Safety Recall 25LA03.

Note: Warranty will not reimburse dealers for repairs completed on vehicles that are not affected or were previously completed, even by another dealer.

III. PREPARATION

A. PARTS

Part Number	Description	Quantity
73350-0E190-C0	BELT ASSY, REAR SEAT, OUTER CENTER (RX)	As Needed
73350-F6010-C0	BELT ASSY, REAR SEAT, OUTER CENTER (NX)	As Needed

B. TOOLS & EQUIPMENT

- Hand Tools
- Torque Wrench
- Plastic Pry Tools

IV. BACKGROUND

The second-row center seatbelt of the subject vehicles may have been damaged during manufacturing. This may cause the seatbelt to not meet certain strength requirements. If an occupant is belted in the second-row center seat with a damaged seatbelt, it may increase the risk of injury during certain crashes.

V. COMPONENTS

Rear Center Seat Belt Assembly

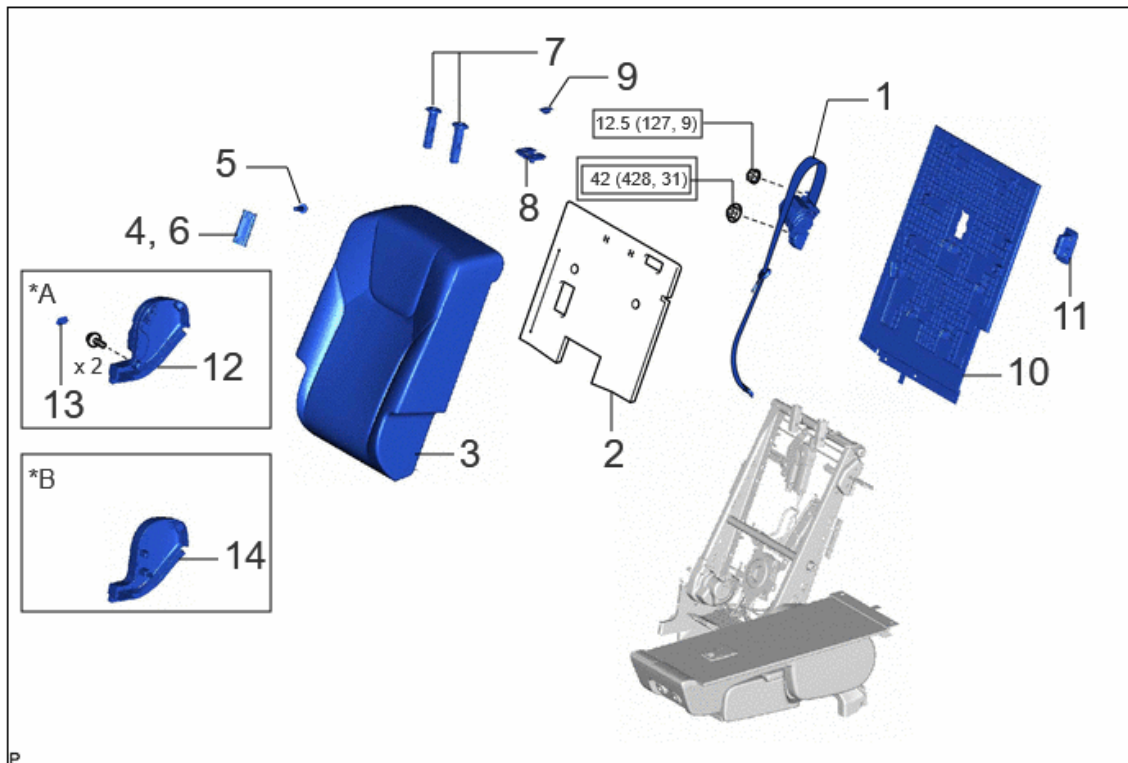

VI. INSPECT THE REAR SEAT BELT



- A. Locate the rear center seat belt
- B. Inspect the rear center seat belt webbing for damage
 - Begin from bottom at seat cushion near anchor bracket
 - Continue to inspect belt webbing up to the top of the seat cushion
 - Slowly pull seat belt out of retractor, continuing to visually inspect front side
 - Using an ungloved fingertip, feel across the belt's surface for any abnormalities in the surface texture.
 - Repeat on the back side as you feed the belt back into the retractor
- C. If damage is found, record inspection result and take photos of the condition. Provide the photos to the parts department for parts release. Once Approved for repair, move to Step VII.
 - If No damage to the seat belt is found, the vehicle can be returned to the customer.

HINT: Use the photos below to confirm NG or OK Condition



Nick Mark = NG

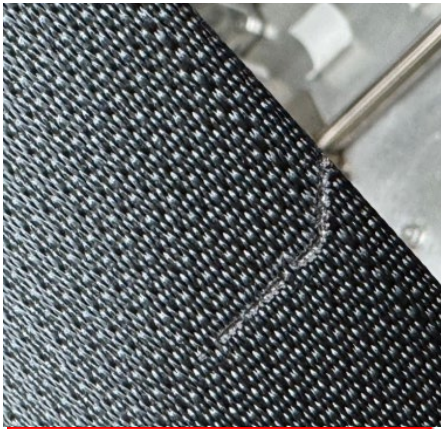

Burn Mark = NG



Burn Mark = NG

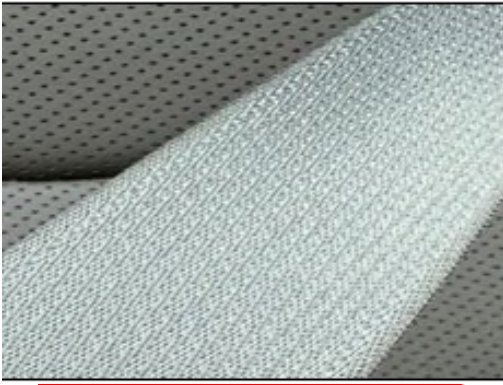

OK



OK

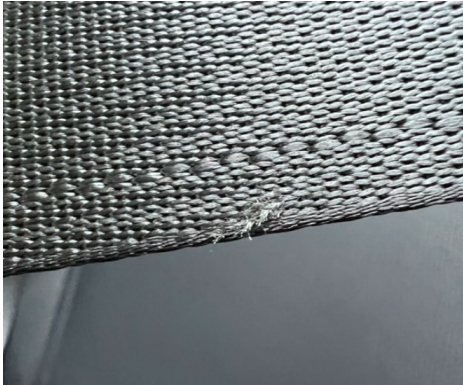

OK

VII. PERFORMING THE REMEDY

1. Remove the Rear Center Seat Belt Assembly

RX:

[Refer to the TIS for instructions on SEAT BELT > REAR SEAT OUTER BELT ASSEMBLY > REMOVAL](#)

NX:

[Refer to the TIS for instructions on SEAT BELT > REAR SEAT OUTER BELT ASSEMBLY > REMOVAL](#)

2. Install the **NEW** Rear Center Seat Belt Assembly

RX:

[Refer to the TIS for instructions on SEAT BELT > REAR SEAT OUTER BELT ASSEMBLY > INSTALLATION](#)

NX:

[Refer to the TIS for instructions on SEAT BELT > REAR SEAT OUTER BELT ASSEMBLY > INSTALLATION](#)

◀ VERIFY REPAIR QUALITY ▶

- Confirm new Seat Belt-Assembly is properly installed and operates correctly.
- Confirm that no new DTCs were introduced during the repair.

If you have any questions regarding this update, please contact your regional representative.

VIII. APPENDIX

PARTS DISPOSAL

In accordance with Federal law, please make sure all recalled parts (original parts) removed from the vehicle are disposed of in a manner in which they will not be reused, *unless requested for parts recovery return*