

January 28, 2025

Version 1

Safety Recall: 2025 MDX Center Information Display

APPLIES TO

Year	Model	Trim Level	VIN Range
2025	MDX	Advance, Advance A-Spec, Advance Type S	Check the iN VIN status for eligibility.

BACKGROUND

Due to improper software programming, the center information display unit may show a black screen after the transmission is shifted from reverse to other drive positions within a certain time. If the transmission is shifted into reverse following this display error, the screen remains black. If a black screen is shown in the center information display unit when the vehicle is driven in reverse, the risk of a crash or injury are increased.

CLIENT NOTIFICATION

Owners of affected vehicles will be sent a notification of this campaign. Do an iN VIN status inquiry to make sure the vehicle is shown as eligible. Some vehicles affected by this campaign may be in your new or used vehicle inventory.

Failure to repair a vehicle subject to a recall or campaign may subject your dealership to claims or lawsuits from the client or anyone else harmed as a result of such failure. Before selling a vehicle in inventory, always check if it is affected by a safety recall by conducting a VIN status inquiry.

CORRECTIVE ACTION

Replace the display screen.

WARRANTY CLAIM INFORMATION

Operation Number	Description	Flat Rate Time	Defect Code	Symptom Code	Template ID	Failed Part Number
8411EX	Replace the center display screen	0.3hr	6DJ00	RKZ00	B25012A	8A700-TYA-A21
8411EXA	Do the steering angle relearn - Add	0.1hr				

PARTS INFORMATION

Part Name	Part Number	Quantity
Display Assy., Center (12.3 inch) (ALPS ALPINE)	8A700-TYA-A22	1

CLIENT INFORMATION: The information in this bulletin is intended for use only by skilled technicians who have the proper tools, equipment, and training to correctly and safely maintain your vehicle. These procedures should not be attempted by "do-it-yourselfers," and you should not assume this bulletin applies to your vehicle, or that your vehicle has the condition described. To determine whether this information applies, contact an authorized Acura automobile dealer.

TOOL INFORMATION

Tool Name	Tool Number	Quantity
Trim Tool Set	SOJATP2014 or SILTRIMTL10	1

Available through the Acura Tool and Equipment Program. To order online, go to *iN* > **Service** > **Quick Links** > **Tool and Equipment Program**, and then search by tool number. To order by phone, call **888-424-6857**.

REPAIR PROCEDURE

1. Disconnect the [12 Volt Battery Terminal](#).
2. Using a trim tool, carefully remove the center speaker cover.

NOTE: Take care not to scratch or damage the dash and speaker cover when inserting the trim tool.

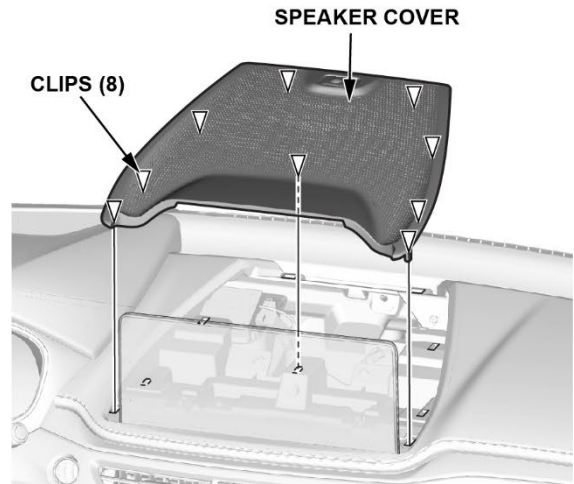
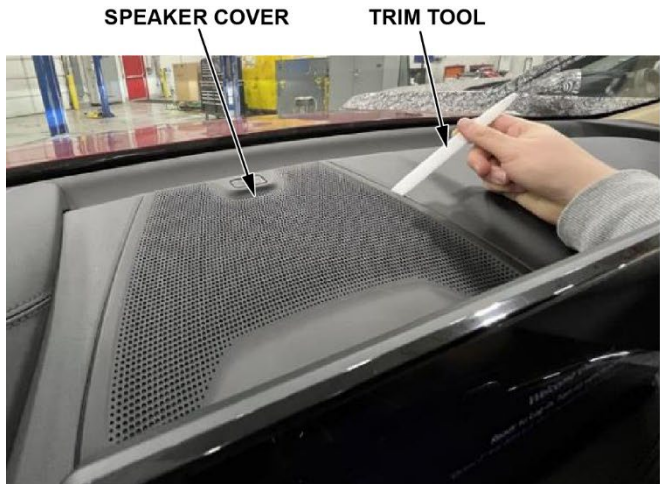

3. Unplug the two connectors from the center speaker and remove the cover speaker assembly from the vehicle.

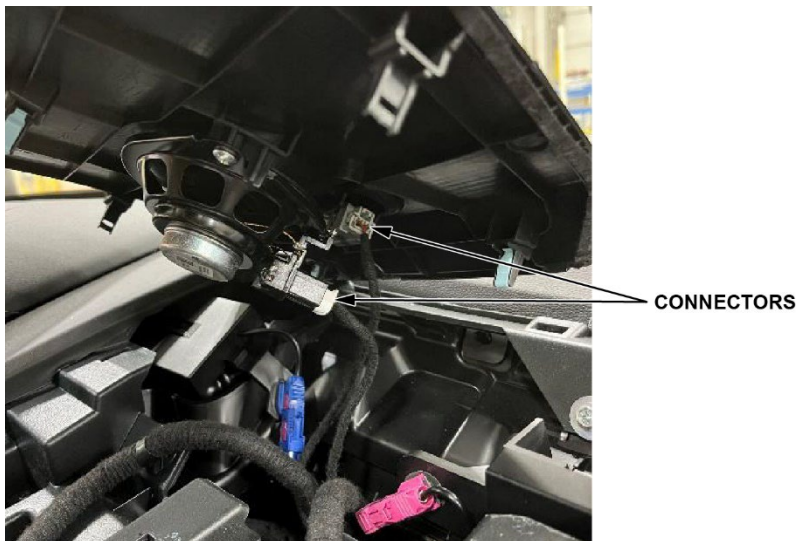

4. Disconnect the three connectors from the center display screen.

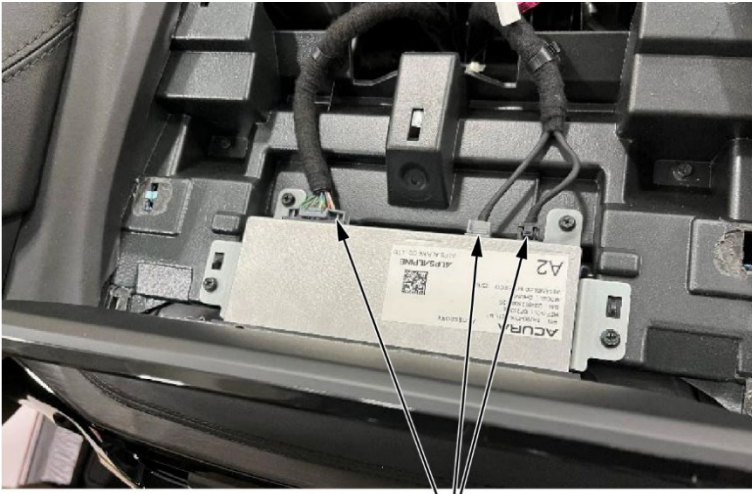

CONNECTORS

5. Remove the four screws that secure the screen.

NOTE: To prevent losing the screws or damaging the interior of the vehicle, **do not** leave the screws in the vehicle, on the dash or on the seats.

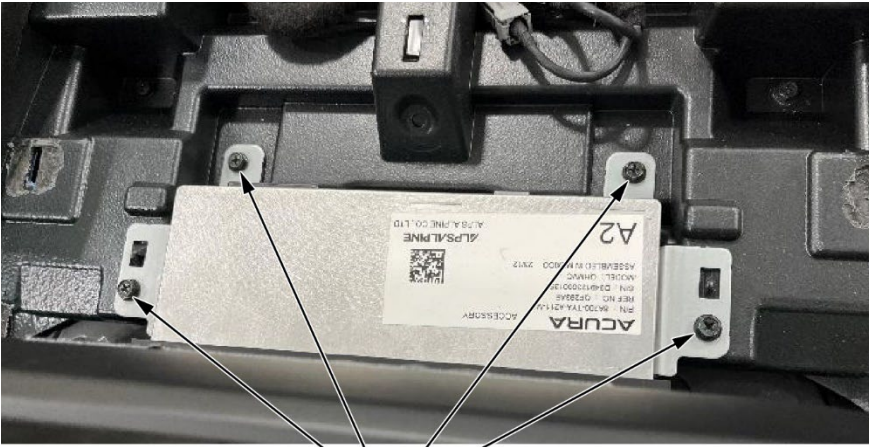

SCREWS

6. First, pivot the screen forward to release the lower tabs from the dash, then slide the screen back to remove.



TABS

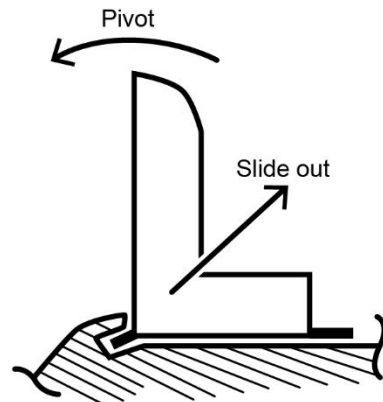

7. Install the new screen and reconnect the connectors.
8. Connect the center speaker and reinstall the center speaker cover assembly onto the dash.
9. Connect the [12 Volt Battery Terminal](#).
10. Turn the vehicle ON, shift the vehicle into reverse, make sure the rear camera image is displayed on the screen. Then shift into other drive positions to ensure the screen is functioning properly.
11. Perform the [Steering Angle Neutral Position Learn](#).

Disposing a Defective Screen:

NOTE:

- Safety glasses and protective gloves recommended.
 - To prevent reusing a defective screen, it is necessary to render the screen useless.
1. Document the defective screen serial number on the repair order.



2. Cover the defective screen using a shop towel and shatter the screen.
3. Properly dispose the defective screen in accordance with federal, state and/or local regulations.