

January 17, 2025

Version 1

Safety Recall: 2024 ZDX Passenger-Side Front Stabilizer Bracket Bolt Inspection

APPLIES TO

Year	Model	Trim Level	VIN Range
2024	ZDX	ALL	Check iN VIN Status for eligibility.

BACKGROUND

During assembly, the passenger-side front stabilizer bar bracket bolts may have been improperly fastened. If the bracket bolt(s) loosens and separates from the vehicle frame, the stabilizer bar and/or bracket can damage the high voltage cables and/or EV battery coolant lines.

CLIENT NOTIFICATION

Owners of affected vehicles will be sent a notification of this campaign. Do an iN VIN status inquiry to make sure the vehicle is shown as eligible. Some vehicles affected by this campaign may be in your new or used vehicle inventory.

Failure to repair a vehicle subject to a recall or campaign may subject your dealership to claims or lawsuits from the customer or anyone else harmed as a result of such failure. To see if a vehicle in inventory is affected by this safety recall, do a VIN status inquiry before selling it.

CORRECTIVE ACTION

Inspect the passenger side front stabilizer bolts, inspect for damage if bolts are missing, replace any damaged parts, replace missing bolts, tighten bolts to proper torque specification.

PARTS INFORMATION

Part Name	Part Number	Quantity
Front Shaft Bracket Bolt (BOLT, FR. STABILZER SHAFT BRACKET)	11589273	1 or 2 (as needed)

NOTE: Parts are controlled for this campaign. Contact your facing parts center analyst for parts requests. Acura expects a very low number of vehicles will require bolt replacement.

REQUIRED MATERIALS

NONE

TOOL INFORMATION

NONE

CLIENT INFORMATION: The information in this bulletin is intended for use only by skilled technicians who have the proper tools, equipment, and training to correctly and safely maintain your vehicle. These procedures should not be attempted by "do-it-yourselfers," and you should not assume this bulletin applies to your vehicle, or that your vehicle has the condition described. To determine whether this information applies, contact an authorized Acura automobile dealer.

WARRANTY CLAIM INFORMATION

Operation Number	Description	Flat Rate Time	Defect Code	Symptom Code	Template ID	Failed Part Number
4165A6	Inspect right front stabilizer bracket bolts & torque to specification.	0.4 hr	6XD00	KKY00	B25013A	84739114
4161K6	Replace right front stabilizer bracket (1) bolt & torque to specification (includes inspection).	0.5 hr	6XD00	KKY00	B25013B	84739114
4161K6	Replace right front stabilizer bracket (2) bolts & torque to specification (includes inspection).	0.5 hr	6XD00	KKY00	B25013C	84739114

REPAIR PROCEDURE

1. Remove the front right tire and wheel assembly.
 - [Tire and Wheel Removal and Installation](#)
2. Remove the mounting bolts (circled) for the rear half of the wheelhouse liner, then move the rear half of the wheelhouse liner to allow access to the front stabilizer bar mounting bolts.

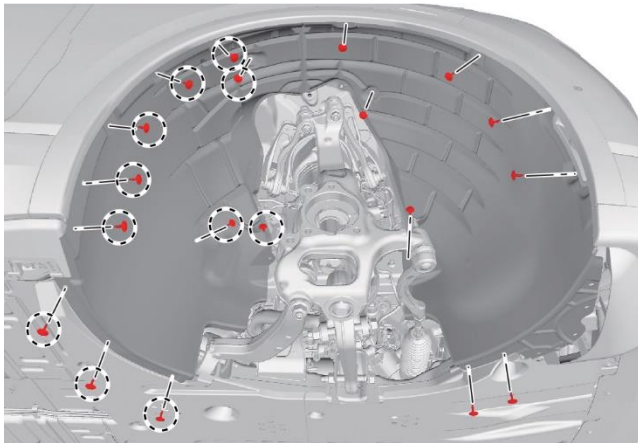

3. Release the harness and brake line from the two mounting clips.

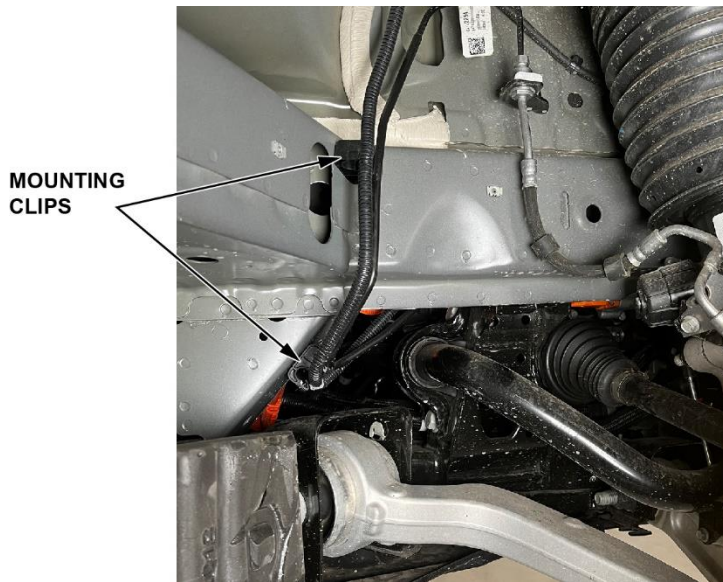

4. Make a reference mark on both bolts and the stabilizer bar bracket with a paint pen.
NOTE: If any bolts are missing, refer to the appropriate Required Action in Step 5.

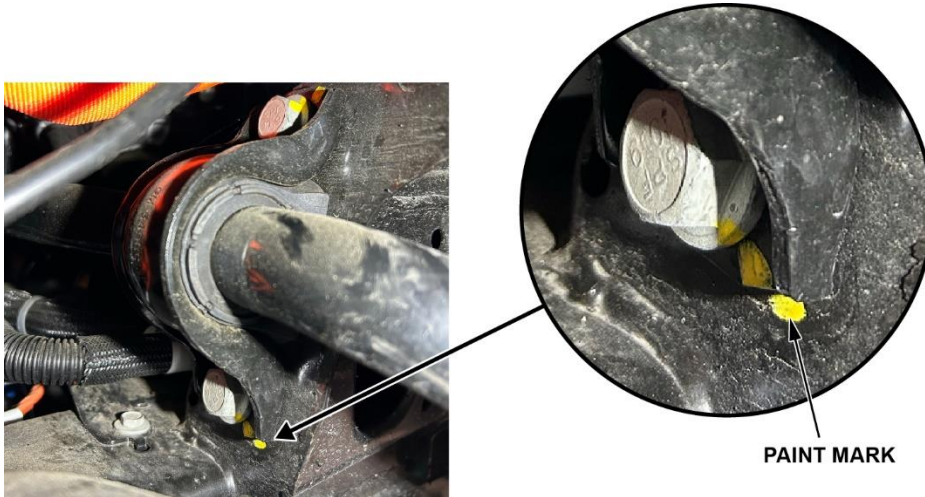

5. Torque both right-side front stabilizer bar bracket bolts to **10 N·m (7 lb-ft)**, then check the paint marks to see if the bolts have moved:

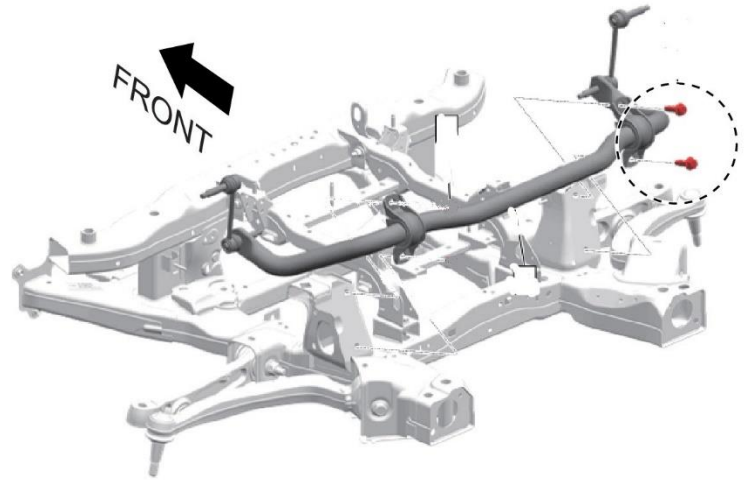

Bolt Status	Required Action
Neither of the two bolts have moved.	Torque the two passenger-side front stabilizer bar bracket bolts to 100 N·m (74 lb-ft) .
One bolt moved, or is missing.	Replace the loose or missing bolt with a new bolt, then torque the two passenger-side front stabilizer bar bracket bolts to 100 N·m (74 lb-ft) .
Both bolts have moved.	Replace both bolts with new bolts, then torque the two passenger-side front stabilizer bar bracket bolts to 100 N·m (74 lb-ft) .
Both bolts are missing.	Inspect the EV battery cable, the drive motor battery charger inlet hose, the drive motor power distribution control module hose, and the stabilizer bar for any damage. Replace any damaged components. Replace both bolts with new bolts, then torque the two passenger-side front stabilizer bar bracket bolts to 100 N·m (74 lb-ft) .

EV BATTERY CABLE

DRIVE MOTOR BATTERY CHARGER INLET HOSE

DRIVE MOTOR POWER DISTRIBUTION CONTROL MODULE HOSE



6. Reinstall all removed parts in reverse order of removal.