



# IMPORTANT SAFETY RECALL

This notice applies to your vehicle. Refer to the provided list.

**NHTSA Recall Number:** 25V663

**Altec Identifier:** CSN-3257

April 23, 2026

Dear Altec Owner,

For US owners, this notice is sent to you in accordance with the *National Traffic and Motor Vehicle Safety Act*. For Canadian owners, this notice is sent to you in accordance with the requirements of the *Motor Vehicle Safety Act*. This is to inform you that your vehicle may contain a defect that could affect the safety of a person.

Altec Industries, Inc. has decided that a defect which relates to motor vehicle safety exists in certain ST600 units built from April 2022 through July 2024. These units could experience extended periods of high current draw in the voltage regulator on the spray unit auxiliary engine enclosure. Damage to the voltage regulator can generate heat or a fire in the auxiliary engine enclosure, **increasing the risk of death or serious injury**.

Refer to the included notice for the items covered under the Altec Warranty Policy. If you had this repair performed before you received this notice, you may be eligible to receive reimbursement for the cost of obtaining a pre-notification remedy of the problem associated with this recall.

Compare your unit's identifying information with the provided list to verify your unit is affected. You may also contact Altec or view your fleet through Altec Connect to determine if there are any other outstanding notices.

The repair, consisting of rewiring the Vanguard engine voltage regulator and start solenoid, can be performed by a qualified person, or you may contact Altec for further assistance. The repair is expected to take 15 minutes and one person to complete. All work will be performed at no charge to the customer when presented for repair.

Please be aware that Altec Service will not service units over 25 years old, as indicated by the unit's serial number. If your unit has reached 25 years since manufacture, Altec Service will not carry out the work described in this notice. This work must be performed by a qualified person and is covered by the listed warranty considerations.

If your model is on the obsolete list, it has reached Altec's recommended end of product life, and Altec recommends removing it from service. Warranty coverage for obsolete units addressed in this notice will not apply. Unit status for End of Service or End of Product Life will be included with the provided unit list. Contact Altec for further guidance if needed.

If you have sold or retired the unit, update the records through Altec Connect. If you have leased this equipment to another person or company, you are required by Federal Law to forward a copy of this notice to the lessee by first class mail within ten (10) days of the receipt of this notice.

For US owners: After contacting Altec, if you are still not able to have the safety condition remedied without charge and within a reasonable time, you may submit a complaint to: Administrator, National Highway Traffic Safety Administration, 1200 New Jersey Avenue SE, Washington, DC 20590 or call toll-free 1-888-327-4236 (TTY 1-888-275-9171) or go to <http://www.safercar.gov>.

For Canadian Owners: If you are still not able to have the safety condition remedied by your dealer within a reasonable time, please contact Altec.

We regret this inconvenience; however, we are taking this action in the interest of your safety and continued satisfaction with Altec products. Thank you for your immediate attention on this important matter.

## Voltage Regulator Damage

**Units Affected:** Certain ST600 spray trucks built from April 2022 to July 2024. Verify your unit is affected by reviewing the attached list or accessing Altec Connect.

**Background:** Altec has learned that the voltage regulator on the spray unit auxiliary engine can experience extended periods of high current draw that could cause damage. The damage could generate heat or a fire.

**WARNING**

**Death or serious injury could result from a fire. Follow the modified operation procedure to remove the potential for a voltage spike that could damage the voltage regulator.**

**Customer Action:** Complete the Repair Procedure beginning on page 2, or contact Altec to complete this work. Complete this work by the next preventive maintenance cycle or within 30 days of receipt of this notice.

Subsequent damage due to failure to perform the required action(s) in the time period allowed will not be covered by warranty.

**Ask your service provider to check for any outstanding notices at your next appointment.**

**Requirements:** The repair is estimated to take less than 15 minutes and one person to complete.

**Completion and Warranty:** The repair is covered under the Altec Warranty Policy and can be performed by Altec, the customer, or the customer’s warranty provider. Altec will perform the work for free at an Altec facility. If the customer or the customer’s warranty provider performs the work, a warranty claim must be submitted to be reimbursed for the cost of the labor. Altec will allow up to \$22.50 for the labor to perform the repair. Customers are responsible for the travel costs of an Altec Mobile Service technician if the technician performs the work at the owner’s location

**Altec Contact Info:**

Phone: 1-877-GO ALTEC (1-877-462-5832) — Altec Connect Customer Portal: [altec.com/altec-connect/](https://altec.com/altec-connect/)

Altec Use Only	
Inspection labor	0.0 hr (Service); 0.0 hr (other)
Repair labor	0.75 hr (Service); 0.25 hr (other)
Account #	010.1067.43156.000.9574.000
Travel	Not included
NHTSA code	90
Prime fail P/N	NA
Kit instructions	N/A

Altec Use Only			
Description	Part No.	Qty	Warranty
N/A	N/A	N/A	N/A

## Repair Procedure:

1. Read and understand all steps of the instructions before beginning the procedure. Wear appropriate personal protective equipment (PPE) following your employer's requirements.
2. Turn both Vanguard engines off using the key switches (refer to Figure 1).

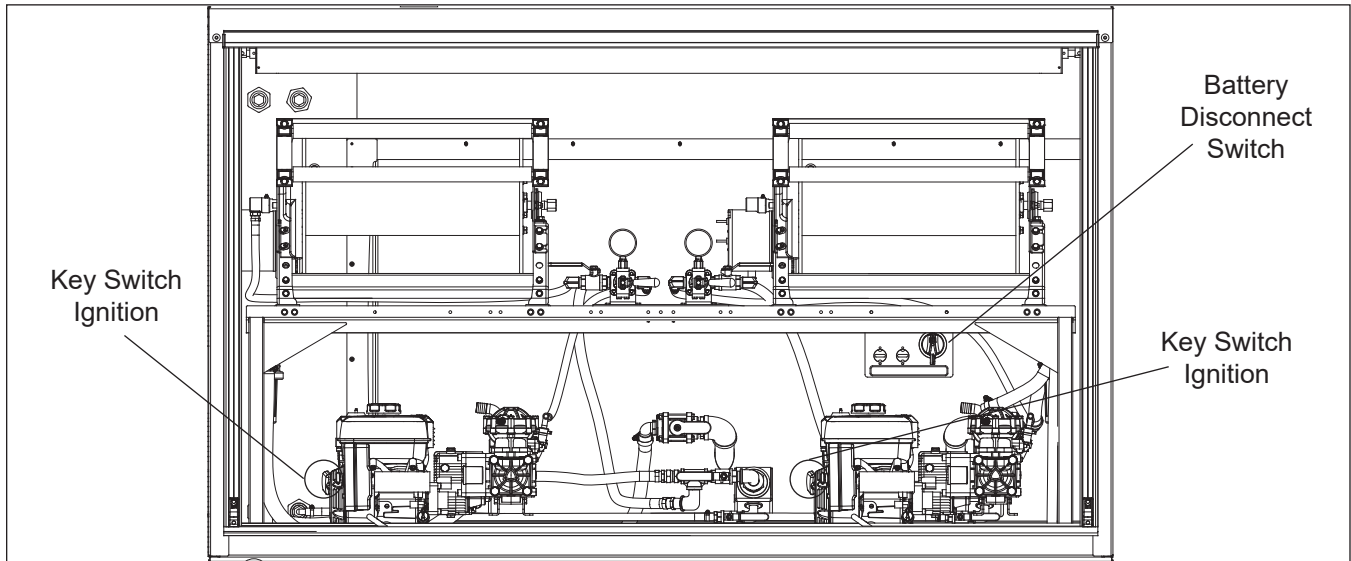

**Figure 1 — Battery Disconnect Switch**

3. Move the battery disconnect switch (refer to Figure 1) to the Off position.
4. Locate rear Vanguard engine voltage regulator and start solenoid (refer to Figure 2).

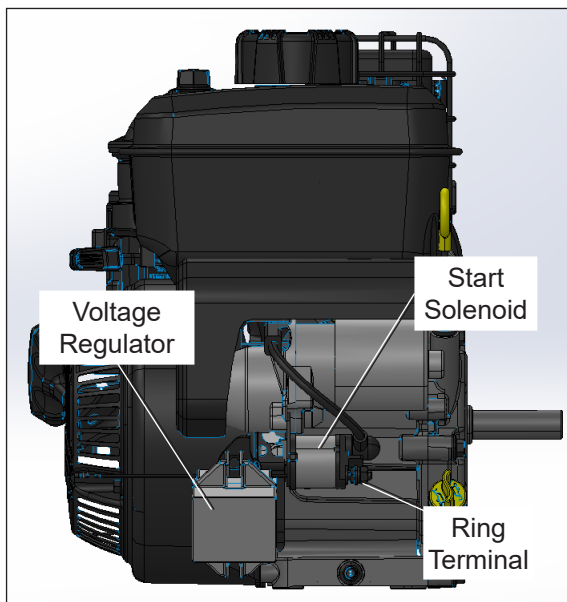

**Figure 2 — Engine**



**Figure 3 — Connector**

5. Disconnect the 2-pin connector with yellow wires from the stator to the voltage regulator. Wrap the stator-side connector with electrical tape to prevent shorting to ground (refer to Figure 3). Tie up the loose ends with the connector facing down to prevent rubbing or water intrusion.

6. Disconnect the red wire ring terminal from the voltage regulator at the starter solenoid stud (refer to Figure 2). Wrap the ring terminal with electrical tape to prevent contacting the battery terminal on the solenoid. Tie up the loose ends to prevent rubbing.
7. Repeat steps 3 through 6 for the front Vanguard engine, if applicable.
8. Leave the battery disconnect switch in off position while the spray unit is not in use.
9. Put the unit back into service.
10. Complete the Inspection and Repair Sheet at the end of this notice, and return it to Altec. If the repair was performed by Altec, mark this notice as complete on the Service Request.

# INSPECTION AND REPAIR SHEET

Complete this form and submit it to Altec to document a completed inspection that results in no repair or a repair that did not require a parts kit to complete.

Choose one of these options for submission.

- Scan the Product Safety QR code and complete the form.
- Complete, scan, and email this page to [product.safety@altec.com](mailto:product.safety@altec.com)
- Online through the customer portal – Altec Connect\*

\*If the customer or the customer’s warranty provider performs the repair, submit a warranty claim through Altec Connect to be reimbursed for the cost of the parts and/or labor.



Product Safety



Altec Connect

Model	Altec Unit Serial Number	Date Inspected

Company Name \_\_\_\_\_ Phone \_\_\_\_\_

Service Company Name \_\_\_\_\_ Phone \_\_\_\_\_

Company Contact \_\_\_\_\_

Company Mailing Address \_\_\_\_\_

City \_\_\_\_\_ State/Province \_\_\_\_\_

ZIP/Mailing Code \_\_\_\_\_ Country \_\_\_\_\_

Signature \_\_\_\_\_

Submission of this form does not order parts or schedule service from Altec.

Contact Altec for more information or to schedule the work to be done by Altec.

Make copies of this form for additional units if needed.

Rev.	Date	Description
A	11/21/2025	Released
B	04/23/2026	Final repair added