

**F1027 A-B**

**Creation Date:** December 2025  
**Revision Date:** January 2026  
**Second Revision Date:** January 2026  
**NHTSA #** 25V-760  
**NHTSA #** 25E-072  
**Transport Canada #** 2025-610

## Subject: TufTrac Axle Clamp Group

Models Affected					
Make	Model	Model Year Start	Model Year End	Production Start Date	Production End Date
Freightliner	108SD	2020	2026	September 12, 2019	September 3, 2025
	114SD	2020	2026	August 9, 2019	September 4, 2025
	122SD	2021	2023	January 22, 2020	December 21, 2022
	Business Class M2	2020	2026	August 15, 2019	September 2, 2025
Western Star	4700	2023	2023	February 10, 2022	February 10, 2022
	47X	2021	2026	July 8, 2020	September 18, 2025
	48X RHD	2022	2022	March 24, 2021	March 24, 2021
	49X	2020	2026	March 20, 2019	September 15, 2025

### General Information

**SECOND REVISION:** The work instruction has been revised to refine the method used to assess the gap between the casting and the axle housing by adding an additional visual check, clarify that wheel and tire removal is not required for inspection.

On behalf of the entities listed below, Daimler Truck North America LLC (DTNA) has decided that a defect that relates to motor vehicle safety exists on the vehicles mentioned above.

- Freightliner Trucks Division
- Wholly owned subsidiary Western Star Truck Sales, Inc.

**PROBLEM:** The fasteners in the axle clamp group on certain vehicles may not have been properly tightened and can loosen and fail. As a result, the axle could shift, leading to a loss of vehicle control, increasing the risk of a crash.

**SOLUTION:** A Daimler Truck North America authorized service facility will inspect and tighten the fasteners on the axle clamp group and replace the castings on the axle clamp group as needed.

There are approximately 21,855 vehicles involved.

### Additional Repairs

Dealers must complete all outstanding Recall and Field Service campaigns prior to the sale or delivery of a vehicle. A dealer

## F1027 A-B

<b>Creation Date:</b>	<b>December 2025</b>
<b>Revision Date:</b>	<b>January 2026</b>
<b>Second Revision Date:</b>	<b>January 2026</b>
<b>NHTSA #</b>	<b>25V-760</b>
<b>NHTSA #</b>	<b>25E-072</b>
<b>Transport Canada #</b>	<b>2025-610</b>

will be liable for any progressive damage that results from its failure to complete campaigns before sale or delivery of a vehicle.

Owners may be liable for any progressive damage that results from failure to complete campaigns within a reasonable time after receiving notification.

Please contact Warranty Campaigns for consideration of additional charges prior to performing the repair.

## Work Instructions

Please refer to the attached work instructions. Prior to performing the campaign, check the vehicle for a completion sticker (Form WAR260).

## Replacement Parts

**NOTE:** Only approximately 2% of vehicles require replacement of the castings on the axle clamp group. Each vehicle must first be inspected following the work instructions.

### **IMPORTANT - After Repair is Complete\*:**

Attach a red completion sticker (WAR260) to the base label (WAR259).

If the vehicle does not have a base label, clean a spot on the appropriate location, and attach a base label, prior to attaching the completion sticker.

If a campaign kit is not required, write the campaign number on a blank sticker and attach it to the base label.

(Failure to install a completion sticker may result in a chargeback of the campaign claim.)

\* TBB is exempt from the completion sticker process

## Removed Parts

- For U.S. and Canadian Dealers, use the part disposition in OWL to determine how to manage removed parts (return, scrap, etc.). Dispositions are available at the date of the repair.
- For Export Dealers, destroy removed parts unless otherwise advised.

## Claim Reimbursement – Labor Allowance

**IMPORTANT:** OWL must be viewed prior to performing the Recall to ensure the vehicle is involved and the campaign has not been previously completed. Also, check for a completion sticker prior to beginning work.

You will be reimbursed for your parts, labor, and handling (landed cost for Export Distributors) by submitting your claim

**F1027 A-B**

<b>Creation Date:</b>	<b>December 2025</b>
<b>Revision Date:</b>	<b>January 2026</b>
<b>Second Revision Date:</b>	<b>January 2026</b>
<b>NHTSA #</b>	<b>25V-760</b>
<b>NHTSA #</b>	<b>25E-072</b>
<b>Transport Canada #</b>	<b>2025-610</b>

through the Warranty system within 30 days of completing this campaign.

- In OWL, use the 'Retrieve' function and select the appropriate procedure. This will auto-populate the PFP, component code, replacement parts, cause, corrective action and SRT code.

**F1027 A-B**

<b>Creation Date:</b>	<b>December 2025</b>
<b>Revision Date:</b>	<b>January 2026</b>
<b>Second Revision Date:</b>	<b>January 2026</b>
<b>NHTSA #</b>	<b>25V-760</b>
<b>NHTSA #</b>	<b>25E-072</b>
<b>Transport Canada #</b>	<b>2025-610</b>

**Table 1 – Claim Reimbursement Table**

<b>Claim Type</b>	Recall Campaign
<b>Campaign</b>	F1027 A-B
<b>VMRS Component Code</b>	F99-999-005
<b>Cause Code</b>	A1 – Campaign
<b>Primary Failed Part</b>	25-F1027-000

**Table 2 – Labor Allowance for F1027 A-B**

<b>Groups</b>	<b>Procedure</b>	<b>Time Allowed (hours)</b>	<b>SRT Codes</b>	<b>Corrective Action</b>
AB	Inspect Tufrac Axle Clamp Group	1.4	996-R259A	06-Inspect
AB	Retorque First Axle Clamp Group	4.5	996-R259B	12-Repair Recall/Campaign
AB	Retorque Both Axle Clamp Groups	5.6	996-R259C	12-Repair Recall/Campaign

- Claim type is **Recall Campaign**.
- In the Campaign field, enter the campaign number and appropriate group (F1027-A and F1027-B).
- In the Primary Failed Part field, enter 25-F1027-000.
- In the Labor section, enter the appropriate SRT from the Labor Allowance Table. Administrative time will auto-populate if applicable using SRT 939-6010A for 0.3 hours.
- The VMRS Component Code is F99-999-005 and the Cause Code is A1 - Campaign.
- U.S. and Canada – Reimbursement for Prior Repairs. When a customer asks about reimbursement, please do the following:
  - Accept the documentation of the previous repair.
  - Make a brief check of the customer’s paperwork to see if the repair may be eligible for reimbursement. (See the ‘Copy of Owner Letter’ section of this bulletin for reimbursement guidelines.)
  - Submit an OWL Recall Pre-Approval Request for a decision.
  - Include the approved amount on your OWL claim in the Other Charges section.
  - Attach the documentation to the pre-approval request.
  - If approved, submit a ‘based on claim’ for the pre-approval.
  - The Dealer is required to reimburse the customer the appropriate amount.

**F1027 A-B**

<b>Creation Date:</b>	<b>December 2025</b>
<b>Revision Date:</b>	<b>January 2026</b>
<b>Second Revision Date:</b>	<b>January 2026</b>
<b>NHTSA #</b>	<b>25V-760</b>
<b>NHTSA #</b>	<b>25E-072</b>
<b>Transport Canada #</b>	<b>2025-610</b>

**IMPORTANT:** OWL must be viewed prior to performing the recall to ensure the vehicle is involved and the campaign has not been previously completed. Also, check for a completion sticker prior to beginning work.

U.S. and Canadian dealers, contact the Warranty Campaigns Department via the Warranty Support Center at [DTNAPortal.com/WSC](http://DTNAPortal.com/WSC) if you have any questions. Export distributors, submit a WSC ticket or contact your International Service Manager.

U.S. and Canadian Dealers: To return excess kit inventory related to this campaign, U.S. dealers must submit a Parts Authorization Return (PAR) to the Memphis PDC. Canadian dealers must submit a PAR to their facing PDC. All kits must be in resalable condition. PAR requests must include the original purchase invoice number. Export Distributors: Excess inventory is not returnable.

The letter notifying U.S. and Canadian vehicle owners is included for your reference.

Please note that the National Traffic and Motor Vehicle Safety Act, as amended (Title 49, United States Code, Chapter 301), requires the owner's vehicle(s) be corrected within a reasonable time after parts are available to you. The Act states that failure to repair a vehicle within 60 days after tender for repair shall be prima facie evidence of an unreasonable time. However, circumstances of a particular situation may reduce the 60-day period. Failure to repair a vehicle within a reasonable time can result in either the obligation to (a) replace the vehicle with an identical or reasonably equivalent vehicle, without charge, or (b) refund the purchase price in full, less a reasonable allowance for depreciation. The Act further prohibits dealers from selling a vehicle unless all outstanding recalls are performed. Any lessor is required to send a copy of the recall notification to the lessee within 10 days. Any subsequent stage manufacturer is required to forward this notice to its distributors and retail outlets within five working days.

F1027 A-B

<b>Creation Date:</b>	<b>December 2025</b>
<b>Revision Date:</b>	<b>January 2026</b>
<b>Second Revision Date:</b>	<b>January 2026</b>
<b>NHTSA #</b>	<b>25V-760</b>
<b>NHTSA #</b>	<b>25E-072</b>
<b>Transport Canada #</b>	<b>2025-610</b>

## Copy of Notice to Owners

### Subject: TufTrac Axle Clamp Group

**For Notice to U.S. Customers:** This notice is sent to you in accordance with the requirements of the *National Traffic and Motor Vehicle Safety Act*. **For Notice to Canadian Customers:** This notice is sent to you in accordance with the requirements of the Motor Vehicle Safety Act.

Daimler Truck North America LLC (DTNA), on behalf of its Freightliner Trucks Division, and wholly owned subsidiary, Western Star Truck Sales, Inc., has decided that a defect, which relates to motor vehicle safety, exists in certain 2020-2026 Freightliner 108SD, 114SD, 122SD and Business Class M2 and Western Star 4700, 47X, 48X RHD and 49X vehicles. See below for additional details:

Make	Model	Model Yr. Start	Model Yr. End	Prod. Start Date	Prod. End Date
Freightliner	108SD	2020	2026	September 12, 2019	September 3, 2025
	114SD	2020	2026	August 9, 2019	September 4, 2025
	122SD	2021	2023	January 22, 2020	December 21, 2022
	Business Class M2	2020	2026	August 15, 2019	September 2, 2025
Western Star	4700	2023	2023	February 10, 2022	February 10, 2022
	47X	2021	2026	July 8, 2020	September 18, 2025
	48X RHD	2022	2022	March 24, 2021	March 24, 2021
	49X	2020	2026	March 20, 2019	September 15, 2025

The fasteners in the axle clamp group on certain vehicles may not have been properly tightened and can loosen and fail. As a result, the axle could shift, leading to a loss of vehicle control, increasing the risk of a crash.

A Daimler Truck North America authorized service facility will inspect and tighten the fasteners on the axle clamp group and replace the castings on the axle clamp group as needed. The Recall will take approximately four hours and will be **performed free of charge**.

Please contact an authorized Daimler Truck North America dealer to arrange to have the Recall performed and to ensure that parts are available.

To locate an authorized dealer, go to <https://northamerica.daimlertruck.com/brands/support>. At the bottom of the page click on the appropriate brand (shown as an icon), and at the top of each brand's page is an option to 'Find a Dealer'.

You may also confirm your vehicle's involvement in this recall at the following URL:  
<https://dtna-dlinfo.prd.freightliner.com:48518/VinLookup/vin-module/getVinLookupPage>.

**F1027 A-B**

<b>Creation Date:</b>	<b>December 2025</b>
<b>Revision Date:</b>	<b>January 2026</b>
<b>Second Revision Date:</b>	<b>January 2026</b>
<b>NHTSA #</b>	<b>25V-760</b>
<b>NHTSA #</b>	<b>25E-072</b>
<b>Transport Canada #</b>	<b>2025-610</b>

You may be liable for any progressive damage that results from your failure to complete the Recall within a reasonable time after receiving notification.

If you do not own the vehicle that corresponds to the identification number(s), which appears on the notification, please return the notification to the Warranty Campaigns Department with any information you can furnish that will assist us in locating the present owner. If you have leased this vehicle, Federal law requires that you forward this notice to the lessee within 10 days. If you are a subsequent stage manufacturer, Federal law requires that you forward this notice to your distributors and retail outlets within five working days. **For Notice to US Customers:** If you have paid to have this recall service condition corrected prior to this notice, you may be eligible to receive reimbursement. Please see the reverse side of this notice for details.

If you have questions about this Recall Campaign, please contact the Warranty Campaigns Department at (800) 547-0712, 7:00 a.m. to 4:00 p.m. Pacific Time, Monday through Friday, e-mail address [DTNA-War-Campaigns@DaimlerTruck.com](mailto:DTNA-War-Campaigns@DaimlerTruck.com). For other concerns, you may contact the Customer Assistance Center at (800) 385-4357. **For Notice to US Customers:** If your manufacturer, distributor, or dealer fails to remedy the defect or noncompliance without charge and within a reasonable time, you may wish to submit a complaint to the Administrator, National Highway Traffic Safety Administration, 1200 New Jersey Avenue SE, Washington, DC 20590; or call the Vehicle Safety Hotline at (888) 327-4236 (TTY: 800-424-9153); or go to <https://www.nhtsa.gov>. **For Notice to Canadian Customers:** If you have a safety concern relating to this Recall, you may wish to contact Transport Canada – Motor Vehicle Safety at, 80 rue Noel, Gatineau, Quebec J8Z 0A1 or phone (800) 333-0510.

We regret any inconvenience this action may cause but feel certain you understand our interest in motor vehicle safety.

WARRANTY CAMPAIGNS DEPARTMENT

Enclosure

**F1027 A-B**

<b>Creation Date:</b>	<b>December 2025</b>
<b>Revision Date:</b>	<b>January 2026</b>
<b>Second Revision Date:</b>	<b>January 2026</b>
<b>NHTSA #</b>	<b>25V-760</b>
<b>NHTSA #</b>	<b>25E-072</b>
<b>Transport Canada #</b>	<b>2025-610</b>

## **Reimbursement to Customers for Repairs Performed Prior to Recall**

If you have already **paid** to have this condition corrected, you may be eligible to receive reimbursement.

Requests for reimbursement may include parts and labor. Reimbursement may be limited to the amount the repair would have cost if completed by an authorized Daimler Truck North America LLC dealer. The following documentation must be presented to your dealer for consideration for reimbursement.

Please provide original or clear copies of all receipts, invoices, and repair orders that show:

- The name and address of the person who paid for the repair
- The Vehicle Identification Number (VIN) of the vehicle that was repaired
- What problem occurred, what repair was done, when the repair was done
- Who repaired the vehicle
- The total cost of the repair expense that is being claimed
- Proof of payment for the repair (such as the front and back of a cancelled check or a credit card receipt)

Reimbursement will be made by check from your Daimler Truck North America LLC dealer.

Please speak with your Daimler Truck North America LLC authorized dealer concerning this matter.

**F1027 A-B**

<b>Creation Date:</b>	<b>December 2025</b>
<b>Revision Date:</b>	<b>January 2026</b>
<b>Second Revision Date:</b>	<b>January 2026</b>
<b>NHTSA #</b>	<b>25V-760</b>
<b>NHTSA #</b>	<b>25E-072</b>
<b>Transport Canada #</b>	<b>2025-610</b>

## Work Instructions

### Subject: TufTrac Axle Clamp Group

Models Affected					
Make	Model	Model Yr. Start	Model Yr. End	Prod. Start Date	Prod. End Date
Freightliner	108SD	2020	2026	September 12, 2019	September 3, 2025
	114SD	2020	2026	August 9, 2019	September 4, 2025
	122SD	2021	2023	January 22, 2020	December 21, 2022
	Business Class M2	2020	2026	August 15, 2019	September 2, 2025
Western Star	4700	2023	2023	February 10, 2022	February 10, 2022
	47X	2021	2026	July 8, 2020	September 18, 2025
	48X RHD	2022	2022	March 24, 2021	March 24, 2021
	49X	2020	2026	March 20, 2019	September 15, 2025

**F1027 A-B**

<b>Creation Date:</b>	<b>December 2025</b>
<b>Revision Date:</b>	<b>January 2026</b>
<b>Second Revision Date:</b>	<b>January 2026</b>
<b>NHTSA #</b>	<b>25V-760</b>
<b>NHTSA #</b>	<b>25E-072</b>
<b>Transport Canada #</b>	<b>2025-610</b>

## Inspection and Re-Tightening of the TufTrac Clamp Group

**SECOND REVISION:** The work instruction has been revised to refine the method used to assess the gap between the casting and the axle housing by adding an additional visual check, clarify that wheel and tire removal is not required for inspection.

1. Check the base label (Form WAR259) for a completion sticker for F1027 (Form WAR260), indicating this work has been done. The base label is usually located on the passenger-side door, about 12 inches (30 cm) below the door latch. If a completion sticker is present, no work is needed. If a completion sticker is not present, proceed to the next step.
2. Park the vehicle on a level surface, shut down the engine, and set the parking brake. Chock the tires.



### **WARNING:**

Never work around or under a vehicle that is supported only by a jack. Always support the vehicle with safety stands. Jacks can slip, allowing the vehicle to fall, which could result in serious injury or death.

3. Raise the vehicle and support the frame rails with jack stands. For detailed instructions on raising and lowering the vehicle, see **Group 00** of the applicable workshop manual.
4. Using a suitable jack, lightly support the rear axles enough to maintain their seating in the clamp group, not to carry the vehicle load.
5. Using a creeper, roll under the vehicle to gain access to the suspension clamp group.  
If the track rod nuts obstruct access to the clamp group fasteners, remove the nuts and rotate them to create sufficient clearance.

**F1027 A-B**

<b>Creation Date:</b>	<b>December 2025</b>
<b>Revision Date:</b>	<b>January 2026</b>
<b>Second Revision Date:</b>	<b>January 2026</b>
<b>NHTSA #</b>	<b>25V-760</b>
<b>NHTSA #</b>	<b>25E-072</b>
<b>Transport Canada #</b>	<b>2025-610</b>

6. Inspect the clamp group for damage and to verify the torque. See [Fig. 1](#) and [Fig. 2](#).

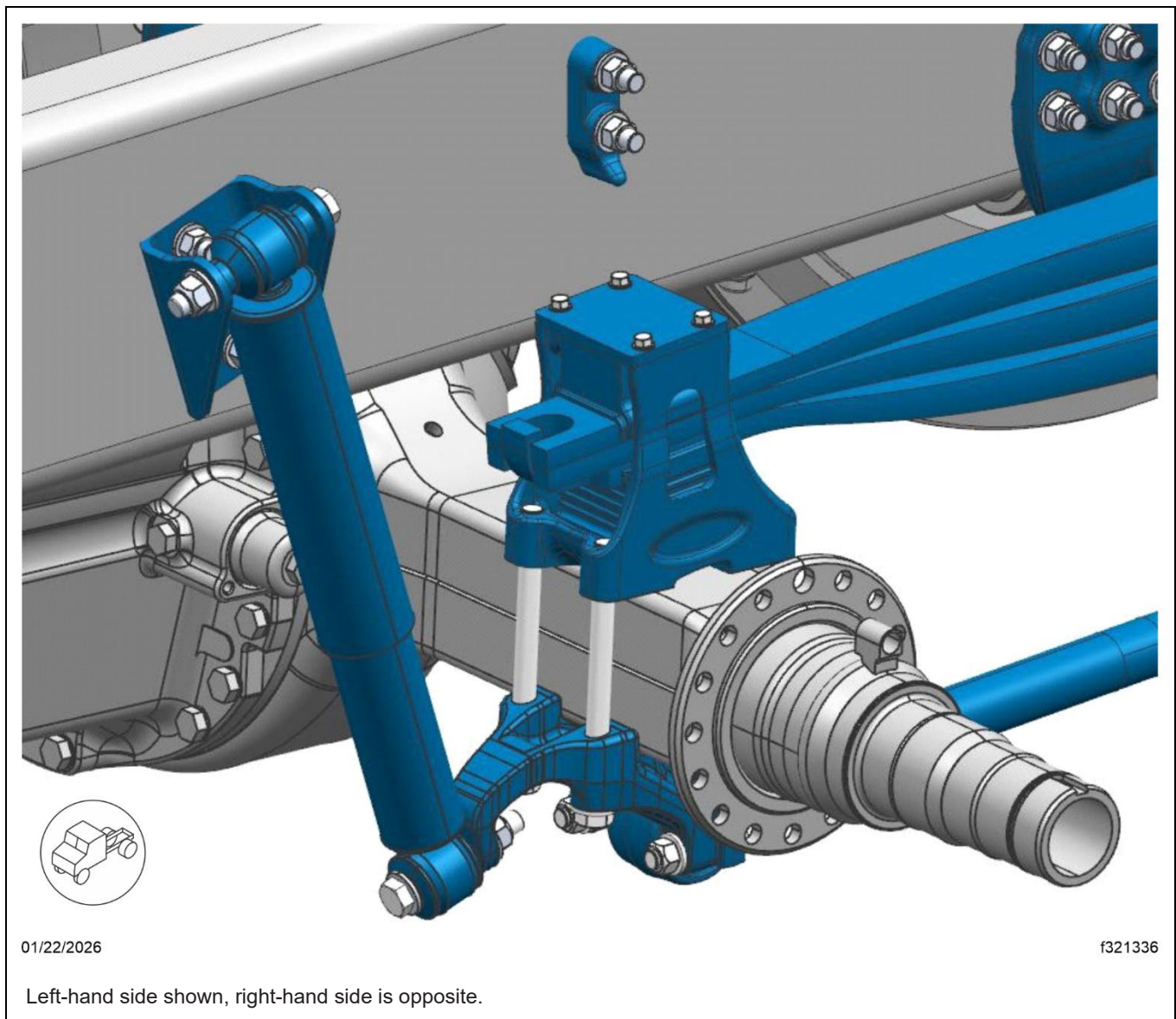

**Fig. 1, Clamp Group, Forward Drive Axle**

F1027 A-B

Creation Date:	December 2025
Revision Date:	January 2026
Second Revision Date:	January 2026
NHTSA #	25V-760
NHTSA #	25E-072
Transport Canada #	2025-610

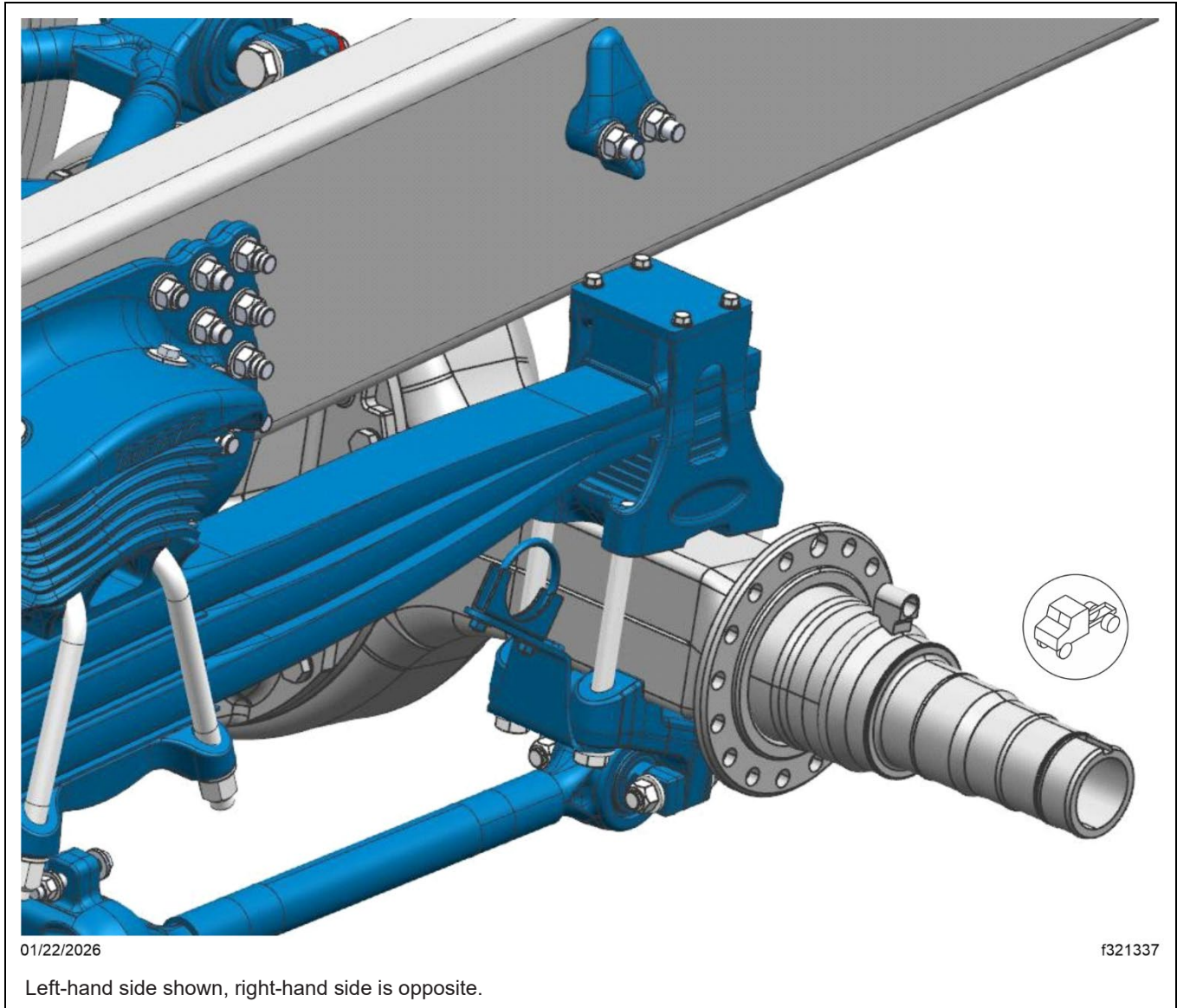

**Fig. 2, Clamp Group, Rear Drive Axle**

F1027 A-B

Creation Date:	December 2025
Revision Date:	January 2026
Second Revision Date:	January 2026
NHTSA #	25V-760
NHTSA #	25E-072
Transport Canada #	2025-610

## NOTICE

Uneven mating surfaces can cause the feeler gauge to produce inaccurate readings, making the casting and axle gap appear out of specification. If a gap is detected, verify clamp group contact with the mating surface using a flashlight.

7. Inspect each corner of the clamp group with a 0.015-inch feeler gauge, as shown in **Fig. 3**. There should be no gap between the suspension clamp group casting and the axle housing.

Is there any gap between the suspension clamp group casting and the axle housing?

**YES** → The bolts must be replaced, and the lower retainer casting must be inspected. Continue with the next step.

**NO** → Go to step 16.

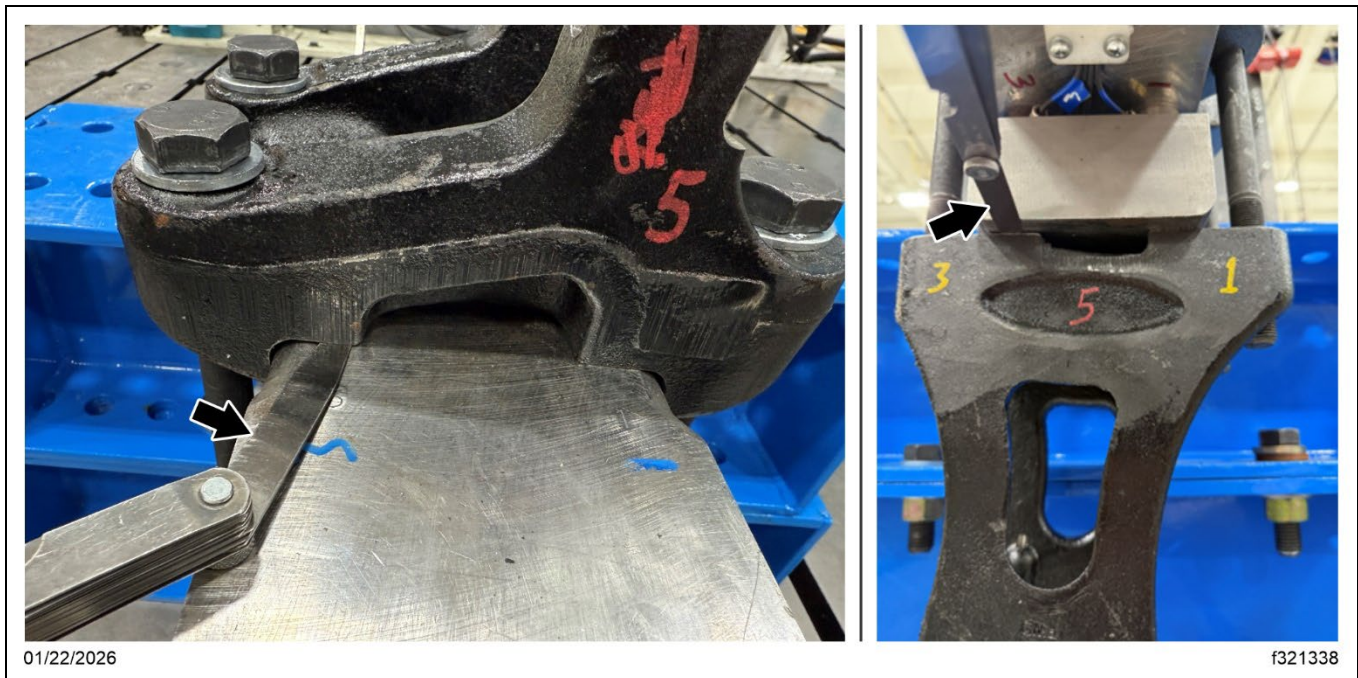

**Fig. 3, Measuring the Gap Using a Feeler Gauge**

8. Remove the wheel and tire assemblies. For instructions, see **Group 40** of the applicable workshop manual.
9. Remove the locknut, retainers, and bushings (if applicable) from the shock absorber lower mount.

F1027 A-B

Creation Date:	December 2025
Revision Date:	January 2026
Second Revision Date:	January 2026
NHTSA #	25V-760
NHTSA #	25E-072
Transport Canada #	2025-610

10. Remove the shock absorber from the lower mount.
11. Remove the bolts. Remove the casting if damaged.

**IMPORTANT:** If the casting needs to be replaced, it is critical that the casting is seated evenly with an even gap on all sides to achieve correct torque and clamping force.

After finger-tightening, lightly wiggle the casting to help it settle and align. Then adjust as needed and hand-tighten again.

12. Position the new casting in place and hand-tighten each bolt evenly.
13. Fasteners that only require re-tightening and are not removed from the casting do not require replacement. Any fastener that is fully removed must be replaced.
14. Use a flashlight to inspect the area between the casting and the axle housing mating surface. Confirm that no light is visible through the mating surface. See [Fig. 4](#).

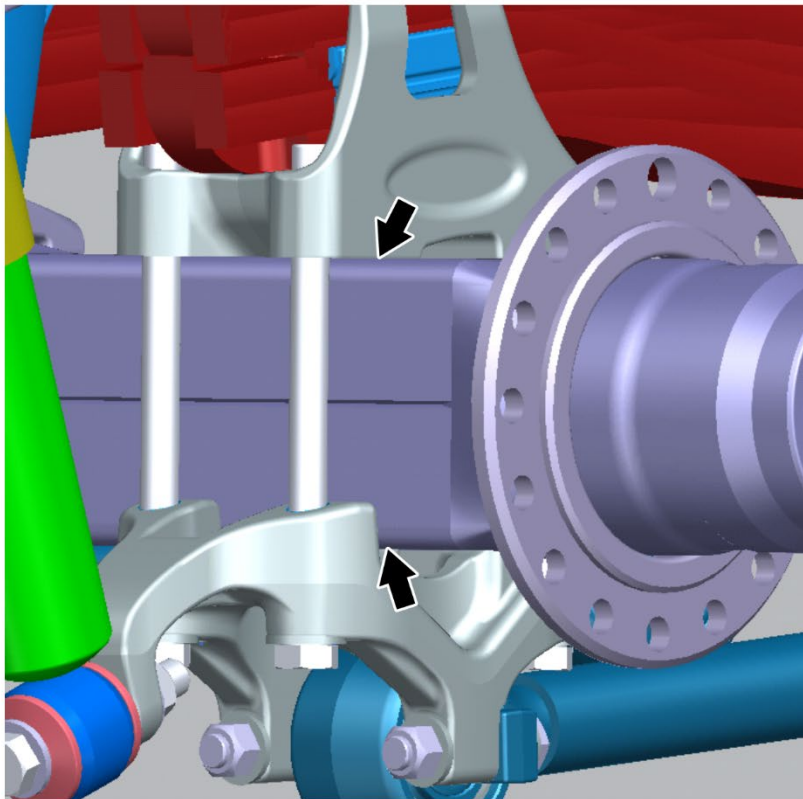

01/22/2026

f321340

The arrows indicate the locations to inspect for any light passing under the casting.

**F1027 A-B**

<b>Creation Date:</b>	<b>December 2025</b>
<b>Revision Date:</b>	<b>January 2026</b>
<b>Second Revision Date:</b>	<b>January 2026</b>
<b>NHTSA #</b>	<b>25V-760</b>
<b>NHTSA #</b>	<b>25E-072</b>
<b>Transport Canada #</b>	<b>2025-610</b>

---

**Fig. 4, Casting and Axle Mating Surface**

15. Measure the total gap at all four corners of the clamp group.
16. Ensure the total gap at each corner does not exceed 0.015 inch for proper presentation and assembly. If the total gap exceeds 0.015 inch, use a flashlight to confirm that the mating surface is in full contact after the fasteners have been tightened to the specified torque.

**IMPORTANT:** Over-tightening one side can lift the casting on the opposite side. If this occurs, loosen the bolt and snug down the other side until the gap is even. Continue hand-tightening until both sides are snug.

17. Continue with the tightening process until the manufacturer's specifications have been met.
18. If no damage is found and the gap is within specifications, use the torque values listed below to tighten the bolts again, if necessary. Ensure to tighten the bolts in a criss-cross pattern, as shown in [Fig. 5](#).

Step 1	Hand Tighten
Step 2	60 lbf·ft (81 N·m)
Step 3	150 lbf·ft (203 N·m)
Step 4	236 lbf·ft (320 N·m)

F1027 A-B

Creation Date:	December 2025
Revision Date:	January 2026
Second Revision Date:	January 2026
NHTSA #	25V-760
NHTSA #	25E-072
Transport Canada #	2025-610

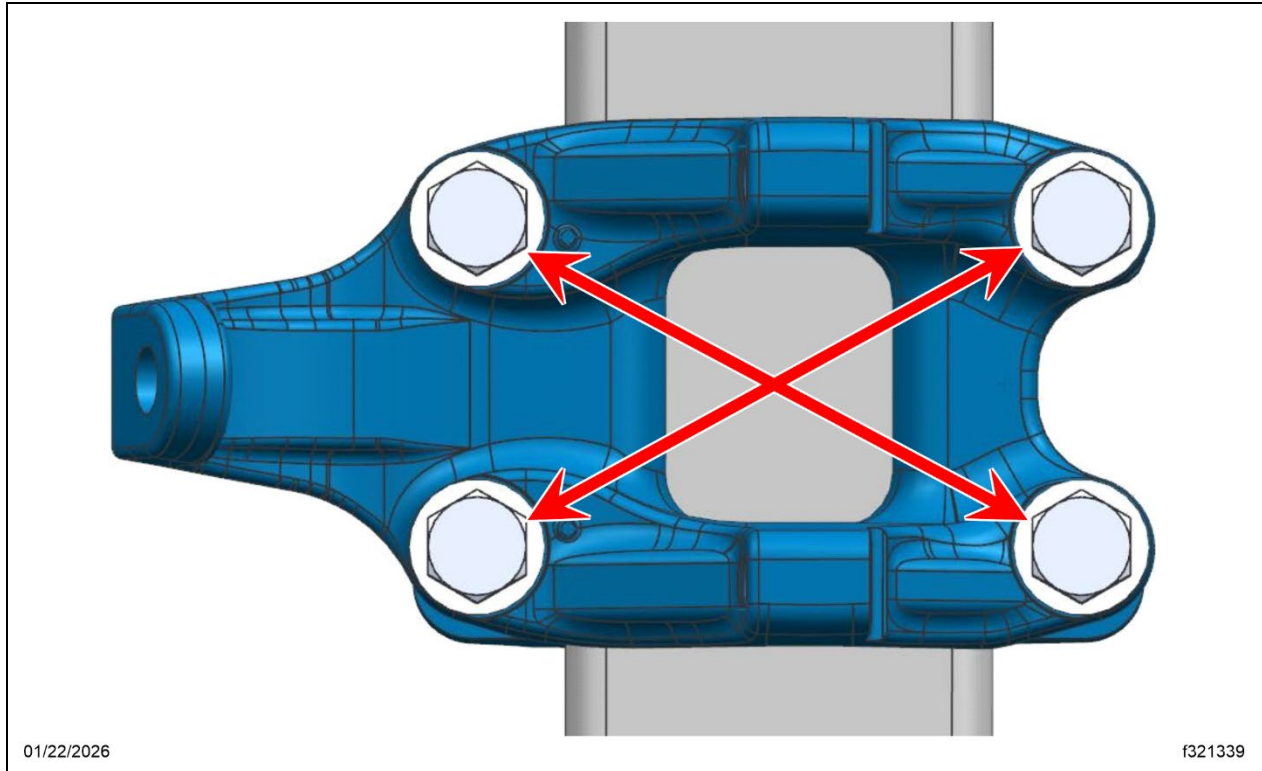

**Fig. 5, Tightening the Bolts in a Criss-Cross Pattern**

19. Install the shock absorber on the lower mount.
20. Repeat steps 6 through 18 for the remaining clamp groups.
21. Install the wheel and tire assemblies. For instructions, see **Group 40** of the applicable workshop manual.
22. Remove the safety stands from under the vehicle, then lower the vehicle. For detailed instructions on raising and lowering the vehicle, see **Group 00** of the applicable workshop manual.
23. Clean a spot on the base label (Form WAR259) and attach a campaign completion sticker for F1027 (Form WAR260).