

**ATTENTION:** Mercedes-Benz Dealer Principals, General Managers, Sales Managers, Service Managers & Parts Managers

## Safety Recall Launch Notification

November 14, 2025

Campaign #	NHTSA ID	Description	<b>Replace Front Short-Range Radar Sensor</b>
2025110002	25V711	25P3091002	

### Campaign Details

Total Recall Population	12	<b>Model(s)/ Platform(s)</b>	G-Class (465 platform)
Vehicles in Dealer Inventory	1		
Model Year(s)	2025		
<b>Issue</b>	Mercedes-Benz AG, the manufacturer of Mercedes-Benz vehicles, has decided that a defect exists on certain subject vehicles. The front short-range radar sensor printed circuit board might not meet current production specifications. As a consequence, object detection might not be sufficiently robust and potentially cause certain driver assistance system functions to deactivate without warning. Furthermore, autonomous partial or full braking might not be initiated as intended. Should a driver rely solely on the driver assistance systems, the risk of a crash might increase.		
<b>What We're Doing</b>	MBUSA will conduct a voluntary recall. An authorized Mercedes-Benz dealer will replace the front short-range radar sensor on the affected vehicles.		
<b>Remedy</b>	The remedy part is available and can be ordered at this time.		
<b>Pending Date</b>	Affected VINs will be flagged in VMI as "OPEN" on Friday, November 14, 2025. The campaign will be visible on the <a href="http://www.NHTSA.gov">www.NHTSA.gov</a> website and may generate questions from customers.		
<b>Approximate Customer Notification Date</b>	Friday, November 28, 2025 Final customer letter can be found at <a href="http://MBUSA.com/recall">MBUSA.com/recall</a> or <a href="http://NHTSA.gov">NHTSA.gov</a> at the time of mailing.		
<b>Warranty Claim Notice</b>	Please note the campaign will close after the warranty claim has been submitted. This change can take at least one-day to reflect in NetStar VMI.		

**Given this notice, it is a violation of federal law for a dealer to sell or lease any new vehicle in dealer inventory covered by this notification until the vehicle has been repaired. Violations of federal law may result in civil penalties.**

- Loaner and demonstrator vehicles may continue to be driven, but must not be retailed until repaired.
- Once the remedy is available, vehicles will be flagged as "OPEN" and Work Instructions will be available.
- As a matter of normal service process, please check for other repair measures that might be applicable to the vehicle(s).

**Additionally, given this notice, it is a violation of federal law for car rental companies to rent vehicles covered by this notification until the vehicle has been repaired. Violations of federal law may result in civil penalties.**

While we regret any inconvenience this may cause, MBUSA is determined to maintain a high level of vehicle quality and customer satisfaction. Please refer all customer inquiries to the Customer Care Center at 1-800-FOR-MERCEDES.



# Recall Campaign Bulletin



Mercedes-Benz

November 2025

**Rev. A December 1, 2025**

TO: ALL MERCEDES-BENZ CENTERS

CAMPAIGN NO.	<b>2025110002</b>
CAMPAIGN DESC.	<b>25P3091002</b>
NHTSA ID	<b>25V711</b>
SUBJECT	<b>Replace Front Radar Sensor</b>
MODEL(S)	<b>G-Class (465 platform)</b>
MODEL YEAR(S)	<b>2025</b>
CAMPAIGN POPULATION	<b>12</b>

## Campaign Technical Instructions

### Prior to performing this Campaign:

Check the Vehicle Master Inquiry (VMI) to verify this campaign applies to the specific vehicle.

Always check for other open campaigns and perform them accordingly!

Review the entire campaign bulletin first, and perform the procedures exactly as described.

### **Revision Note(s):**

- **Updated part number**

Order No. P-RC-2025110002

Recall Campaign Bulletin

Recall Campaign Bulletin

Recall Campaign Bulletin

Recall Campaign Bulletin

Recall Campaign Bulletin

**Primary Parts Information**

Qty.	Part Name	Part Number
1	Front Radar Sensor	A 000 905 64 24

**i** Small parts such as screws, lock nuts, sealing rings, cable ties, fluids, sealant, etc. are not listed in the parts list. The required small parts are taken into account in the budgeting.

**Work Procedure**

1. Replace front **Midrange radar (B92/20)**.

**i** For basic repair information, see AR54.21-P-0701XG.

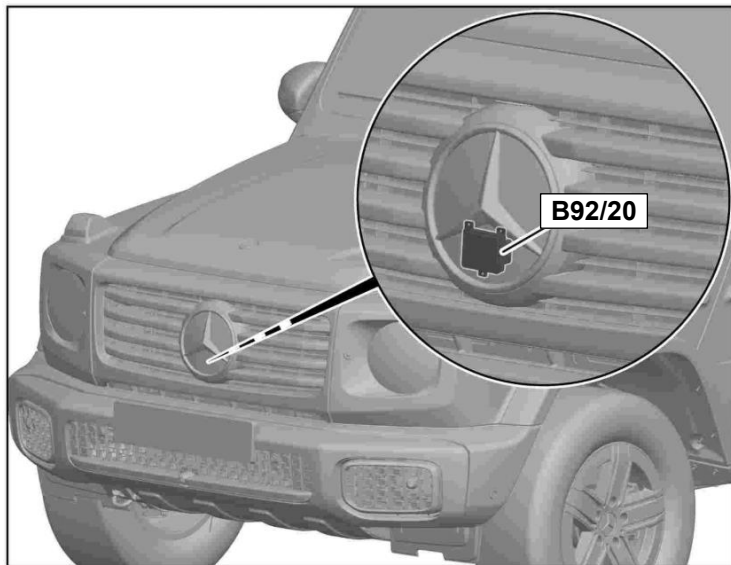
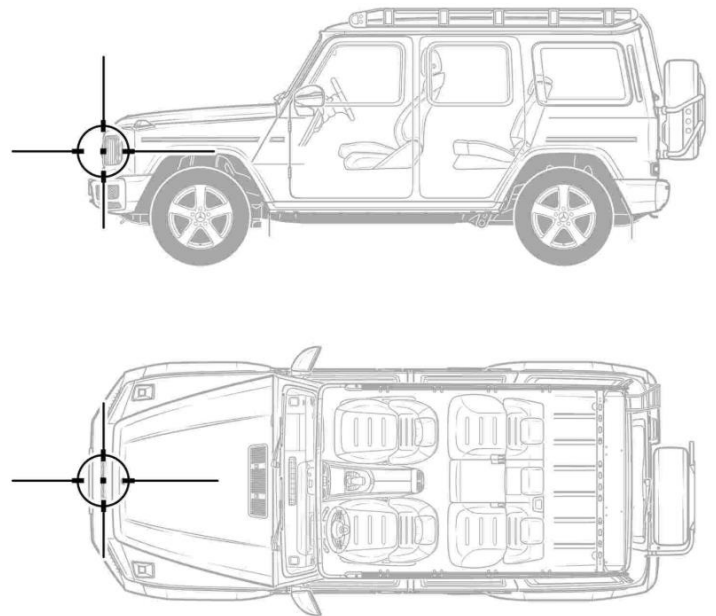

Figure 1



Model(s): 465

**Warranty Information**

**i** **Note:** *The following allowable labor operation should be used when submitting a warranty claim for this repair:*

Damage Code	Operation Number	Description	Labor Time (hrs.)
30 910 02	11-0036	Replace front <b>Midrange radar</b> sensor. <b>Includes:</b> Commissioning radar sensor	0.5
	11-0038*	Perform calibration drive	ZM

\* Calibration drive **Start / Finish mileage** must be documented in the Repair Order text!

**i** **Note:** *Always check Xentry Operation Time (XOT) for the current OP-Code times. Labor times are subject to change and updates may not be reflected in this document.*