



Service Engineering Operations
Customer Service Division

Ford Motor Company
PO Box 1904
Dearborn, Michigan 48121

May 29, 2026

TO: All U.S. Ford and Lincoln Dealers

SUBJECT: **NEW VEHICLE DEMONSTRATION / DELIVERY HOLD**
Safety Recall 25S92
Certain 2015-2017 Model Year Mustang Vehicles
Seat Belt Anchor Pretensioner Inspection

REF : **NEW VEHICLE DEMONSTRATION / DELIVERY HOLD - Advance Notice –**
Safety Recall 25S92 - Supplement #1
Dated: October 16, 2025

AFFECTED VEHICLES (U.S. Population Of Affected Vehicles 328,266)

Vehicle	Model Year	Assembly Plant	Build Date Range
Mustang	2015	Flat Rock	February 11, 2014 to July 31, 2015
	2016		February 20, 2015 to June 1, 2016
	2017		February 11, 2016 to October 2, 2017

Affected vehicles are identified in OASIS and FSA VIN Lists.

REASON FOR THIS SAFETY RECALL

Exposure to a corrosive environment (where use of road salt is prevalent in winter months as an example) may weaken the driver and/or front passenger seat belt anchor pretensioner cables or cause them to separate from their anchor pretensioner assemblies. Weakened or separated cables reduce the effectiveness of the seat belt restraint system in a crash, increasing the risk of injury.

SERVICE ACTION

Before demonstrating or delivering any new in-stock vehicles involved in this recall, dealers are to perform a seat belt anchor pretensioner inspection, trim the carpet around the seat belt anchor pretensioners, inspect the outer seat belt track bolts, and replace a body plug in the front door hinge area per the attached technical instructions. For new vehicle storage guidelines, refer to EFC13033, Storage Guidelines for New Vehicles.

FSA PROGRAM OPTIONS

Program Option	Eligibility	Comments
Mobile Repair	No	See Mobile Service Repair Assessment Level section below, if applicable.
Over-the-Air (OTA) Update	No	See Over-The-Air (OTA) Updates section of the FSA Policy Document, if applicable.
Rentals	Conditional	See the Rental Vehicles section below, if applicable.
Alternative Transportation Available	No	See Alternate Transportation section in the FSA Policy Document.
Pickup & Delivery (PDL)	Yes	See Pickup & Delivery section in the FSA Policy document.
Towing	No	See Towing section below, if applicable.
Essential Special Service Tools (ESST)	No	See Technical Instructions and/or Workshop Manual (WSM) as needed.
Administrative Allowance	Yes	See Administrative Allowance section in FSA Policy Document, and if applicable, Labor Allowances table below.
Owner Refunds	Yes	See Owner Refunds section below, if applicable.
Photo Submission	Yes	See Repair Photo Submission section below, if applicable.

Note: For further information on certain Program Options above, see the corresponding section within the FSA Policy Document.

OWNER NOTIFICATION MAILING SCHEDULE

Owner letters are expected to be mailed the week of June 1, 2026 or sooner. Dealers should repair any affected vehicles that arrive at their dealerships, whether or not the customer has received a letter.

PLEASE NOTE

Federal law requires dealers to complete this recall service before a new vehicle is delivered to the buyer or lessee. Violation of this requirement by a dealer could result in a civil penalty of up to \$27,168 per vehicle. Correct all vehicles in your new vehicle inventory before delivery.

ATTACHMENTS

- Technical Instructions
- Owner Notification Letter
- Recall Reimbursement Plan

REFERENCE MATERIAL

- Warranty & Policy Manual (located on FMCDealer Warranty Portal Page):
www.fmcdealer.dealerconnection.com/content/fmcdealer/us/en/parts_service/wty.html
- FSA Policy Document (located on FMCDealer FSA Resources Page for Ford and Lincoln dealerships):
www.fmcdealer.dealerconnection.com/content/fmcdealer/us/en/parts_service/fsa/rsc.html
- FSA Policy Document (located on the Fleet SharePoint site for Fleets with in-house warranty):
<https://azureford.sharepoint.com/sites/OneWarrantySolution/usfleet/SitePages/Home.aspx>
- The Mobile Repair / Vehicle Pickup & Delivery Record can be found on the Technical Assistance tab in PTS:
<https://www.fordtechservice.dealerconnection.com>

QUESTIONS & ASSISTANCE

For questions and assistance, contact the Special Service Support Center (SSSC) via the SSSC Web Contact Site. The SSSC Web Contact Site can be accessed through the Professional Technician System (PTS) website using the SSSC link listed at the bottom of the OASIS VIN report screen or listed under the SSSC tab.

Customer Service Division

Safety Recall 25S92**MOBILE SERVICE REPAIR ASSESSMENT LEVEL**

- All Vehicles Affected
 - Ⓢ - Not a Mobile Service Repair (MRA5)

OASIS ACTIVATION

OASIS was activated on September 17, 2025.

FSA VIN LISTS ACTIVATION

FSA VIN Lists were available through <https://web.fsavinlists.dealerconnection.com> on September 17, 2025. Owner names and addresses will be available by June 22, 2026.

NOTE: Your FSA VIN Lists may contain owner names and addresses obtained from motor vehicle registration records. The use of such motor vehicle registration data for any purpose other than in connection with this recall is a violation of law in several states, provinces, and countries. Accordingly, you must limit the use of this listing to the follow-up necessary to complete this recall.

SOLD VEHICLES

- Ford has not issued instructions to stop selling/delivering or driving used vehicles under this safety recall. Owners should contact their dealers for an appointment to have their vehicles remedied as soon as practicable. Owners can continue to safely drive their vehicles if they have their vehicles inspected and seat belt anchor pretensioners are assessed to be acceptable.
- Immediately contact any of your affected customers whose vehicles are not on your VIN list but are identified in OASIS. Give the customer a copy of the Owner Notification Letter (when available) and schedule a service date.
- Correct other affected vehicles identified in OASIS which are brought to your dealership.
- Dealers are to prioritize repairs of customer vehicles over repairs of new and used vehicle inventory.

IN-STOCK VEHICLES

- Correct all affected units in your new vehicle inventory before delivery.
- Use OASIS to identify any affected vehicles in your used vehicle inventory.

DEALER-OPERATED RENTAL VEHICLES

The Fixing America's Surface Transportation (FAST) Act law effective June 2016 prohibits a rental company from selling, renting, or leasing vehicles subject to a safety or compliance recall. Please consult your legal counsel for legal advice.

BRANDED / SALVAGED TITLE VEHICLES

Affected branded / salvaged title vehicles are eligible for this recall.

OWNER REFUNDS

- **This Safety Recall must still be performed, even if the owner has paid for a previous repair. Claiming a refund will not close the recall on the vehicle.**
- Ford Motor Company is offering a refund for owner-paid repairs covered by this recall if the repair was performed before the date indicated in the reimbursement plan, which is posted with this bulletin. Owners are directed to seek reimbursement through authorized dealers or, at their option, directly through Ford Motor Company at PO Box 6251, Dearborn, MI 48121-6251.

Safety Recall 25S92**OWNER REFUNDS (continued)**

- Dealers are also pre-approved to refund owner-paid emergency repairs that were performed away from an authorized servicing dealer after the end date specified in the reimbursement plan. Non-covered repairs, or those judged by Ford to be excessive, will not be reimbursed.
- Refunds will only be provided for the cost associated with seat belt anchor pretensioner inspection.

RENTAL VEHICLES

For FSA 25S92 Dealer Bulletin, use the following rental provisions for short or long term rental, when performing the inspection repairs per the Technical Instructions:

Short Term Rentals:

- Dealers are pre-approved for up to 2 days for a comparable rental vehicle. Follow Customer Loyalty Program (CLP) guidelines for dollar amounts.
- Rentals will only be reimbursed for the day(s) the vehicle is at the dealership for part replacement.
- Prior approval for more than 2 rental days is required from the Centralized Loaner Support Team. Contact the Centralized Loaner Support Team via the CRC Dealer Portal for consideration and approval if appropriate.
- Dealers may request a rental vehicle when Ford parts are on backorder; prior approval is required from the Centralized Loaner Support Team via the CRC Dealer Portal.
- If the vehicle is off road, then refer to EFC14236. VOR escalation is required in DOW.
fmcdealer.dealerconnection.com/content/dam/fmcdealer/documents/parts_service/customer/GCCT/Pages/FSALoanerProgram.pdf

Long Term Rentals – Requires SSSC Prior Approval:

- If a customer with open FSA 25S92 experiences a seat belt anchor pretensioner cable rust/corrosion, per the Technical Instructions and photo submission, the SSSC will authorize a long term rental.
- To maximize the customer experience, it is important to provide the customer with a rental while their vehicle is down, waiting for replacement part(s).
- Rental requests are now reviewed/approved by the Central Loaner Support Team (CLT) through the CRC Dealer Portal. Refer to EFC15509 for additional details.
- Submit a request to CLT under FSA 25S92 for consideration and approval, if a vehicle exhibiting the concern is identified for this program, and seat belt anchor pretensioner parts are not available.
- Eligible rental expenses should be claimed on an RO line separate from the repair.
- Use Misc. Expense code “RENTAL” for the rental expenses and sub code 26A04 on the claim.
- The maximum number of days that can be requested on one RO line is 30 days. Submit extensions beyond the initial 30-day request to CLT for approval.
- If the vehicle is off-road, then refer to EFC14236. VOR escalation is required in DOW.
fmcdealer.dealerconnection.com/content/dam/fmcdealer/documents/parts_service/customer/GCCT/Pages/FSALoanerProgram.pdf

Safety Recall 25S92**REPAIR PHOTO SUBMISSION**

Ford requires photo evidence if the inspection reveals rust or corrosion on the seat belt pretensioner components, per the Technical Instructions for this FSA. The SSSC must approve the repair prior to any work being performed.

Action Required

- Contact the SSSC and upload the necessary photos or documentation as attachments for review.
1. **Capture Required Photos (4–6 Photos Total)** Ensure all images are clear, sharp, and legible. You must capture:
 - Open Repair Order (RO): A clear image of the physical or digital RO.
 - VIN Plate: Located on the driver-side (LH) door jamb.
 - Odometer: Showing the vehicle's current mileage.
 - Rust/Corrosion Evidence: Clear image(s) showing red rust on the steel-braided cable of the seat belt pretensioner(s) and/or significant corrosion on the surrounding components on either side.
 2. **Upload the Photos** - You can upload your photos using one of two methods:
 - Desktop (SSSC Web Portal)
 - Upload the photos directly as attachments within the SSSC contact request form when submitting your case.
 - Mobile (PTS Mobile App)
 - Open the PTS Mobile app and go to Images/Files Upload.
 - Select SSSC in the sub-menu and verify that your P&A Code is correct.
 - Select the appropriate FSA and upload the photos.

Note: If you have already started a contact, you can link the photos to your prior Contact ID. If you have not started the SSSC contact yet, upload the photos anyway—the system will automatically link them when you open the contact for this VIN and recall.

3. Submit for Approval & Claiming

- Request Repair Approval: Open an Approval Request contact with the SSSC to review the failed inspection.
- Retrieve SSSC Approval Code: Once approved, the SSSC will provide an approval code. This code is required to submit your claim.
- Request Rental Approval (If Needed): Once you have your SSSC approval code, contact the Centralized Loaner Support Team to obtain a rental approval code for claiming.

ADDITIONAL REPAIR (LABOR TIME AND/OR PARTS)

Additional repairs identified as necessary to complete the FSA should be managed as follows:

- For related damage and access time requirements, refer to the Warranty and Policy Manual / Section 6 – Ford & Lincoln Program Policies / General Information & Special Circumstances for FSAs / Related Damage.
- **For vehicles within new vehicle bumper-to-bumper warranty coverage, no SSSC approval is required**, although related damage must be on a separate repair line with the “Related Damage” radio button checked.
 - Ford vehicles – 3 years or 36,000 miles

Safety Recall 25S92**ADDITIONAL REPAIR (LABOR TIME AND/OR PARTS) (continued)**

- **For vehicles outside new vehicle bumper-to-bumper warranty coverage:**
 - Submit an Approval Request to the SSSC Web Contact Site before completing the repair.
- See “Additional Repair Info” in the FSA Policy Document for further Terms and Conditions.

CLAIMS PREPARATION AND SUBMISSION

- **Technician Competency Requirement:** The STST Competency 10 certification requirement in the U.S. market only will be enforced starting with repair orders opened on or after August 31, 2024. FSA repairs will be rejected, and the claim will not be paid if the repairing technician is not certified in STST Competency 10 FSA. See EFC15936 for more details.
- **Claim Entry:** Enter claims using Dealer Management System (DMS) or One Warranty Solution (OWS) online.
 - When entering claims, select claim type **31**: Field Service Action. The FSA number 25S92 is the subcode.
 - If other services are requested on the same RO, please complete them. Once they are completed, and if the customer elects to take delivery of their vehicle while waiting for parts to arrive to complete this program, dealers should close the repair order. Reference to W&P manual section 1.3.09 for detailed information associated with these applicable process steps.
 - For additional claims preparation and submission information, refer to the Recall and Customer Satisfaction Program (CSP) Repairs in the OWS User Guide.
- **Related Damage/Additional labor and/or parts:** Must be claimed as Related Damage on a separate repair line from the FSA with the same claim type and subcode as described in Claim Entry above.

IMPORTANT: Click the Related Damage Indicator radio button.
- **Rentals:** For rental vehicle claiming, follow Customer Loyalty Program (CLP) guidelines for dollar amounts. Enter the total amount of the rental expense under the Miscellaneous Expense code **RENTAL**.
- **Refunds:** Submit refunds on a separate repair line.
 - Program Code: 25S92 - Misc. Expense: ADMIN
 - Misc. Expense: REFUND - Misc. Expense: 0.2 Hrs.
 - Multiple refunds should be submitted on one repair line and the invoice details for each repair should be detailed in the comments section of the claim.
- **Provision for Locally Obtained Supplies:** Includes: painters masking tape, isopropyl alcohol wipes, anti-corrosion sealer, touch-up paint pen (see miscellaneous part section for details).
 - Submit on the same line as the repair.
 - Program Code: 25S92
 - Misc. Expense: OTHER
 - Misc. Expense for Repairs and Interim Repairs: Claim up to **\$35.00 total**.

Safety Recall 25S92

LABOR ALLOWANCES

Note: Refer to the table below, for the corresponding labor operations.(Additional supplemental labor operations may be claimed from the Supplemental Labor Allowances table.)

Description	Labor Operation & Time (Hours)	
	Coupe	Convertible
<p>NO Rust/Corrosion found on pretensioner braided cables and related components per the Technical Instructions:</p> <ol style="list-style-type: none"> 1. Inspect BOTH seat belt anchor pretensioners for rust/corrosion, cut/trim the carpet on BOTH sides of the vehicle per the Technical Instructions. 2. NO RUST/CORROSION was found on either side (LH/RH) seat belt anchor pretensioner braided cables assemblies. 3. Remove A-pillar body sticker seals. Clean and prepare the paint surface area. 4. Apply anti-corrosion coating sealer and touch-up paint. 5. Install TWO New body plugs. <p>This Labor operation closes FSA 25S92.</p>	<p>25S92B</p> <p>0.5</p>	<p>25S92C</p> <p>0.7</p>

SUPPLEMENTAL LABOR ALLOWANCES **These labor operation codes DO NOT close the FSA.**

Note: Claim any relevant supplemental labor operations in addition to the primary labor operation. Some of the following labor operations, can be claimed after submitting photo evidence to the SSSC.

Description	Labor Operation & Time (Hours)	
	Coupe	Convertible
<p>Rust/Corrosion found on pretensioner braided cables and related components per the Technical Instructions:</p> <ol style="list-style-type: none"> 1. Inspect BOTH seat belt anchor pretensioners for rust/corrosion, cut/trim the carpet on BOTH sides of the vehicle per the Technical Instructions. 2. RUST/CORROSION was found on either side (LH/RH) seat belt anchor pretensioner braided cables assemblies per SSSC photo review. The customer is put in Long Term Rental vehicle, per SSSC approval direction. Proceed with the Technical Instructions. 3. Proceed to remove the A-pillar body sticker seals. Clean and prepare the paint surface area. 4. Apply anti-corrosion coating sealer and touch-up paint. 5. Install TWO New body plugs. 6. Keep the Repair Order open, while the vehicle is under Long Term Rental and waiting for the Dealer Bulletin Supplement. <p>Follow the Technical Instructions for interim repairs. This labor operation does not close FSA 25S92.</p>	<p>25S92EE</p> <p>0.9</p>	<p>25S92FF</p> <p>1.1</p>

Safety Recall 25S92

SUPPLEMENTAL LABOR ALLOWANCES These labor operation codes DO NOT close the FSA.

(continued)

Note: Claim any relevant supplemental labor operations in addition to the primary labor operation.

Description	Labor Operation & Time (Hours)
<p>Rust Found – One or both pretensioners exhibited rust/corrosion per the Technical Instructions and outboard seat track bolts also exhibited red rust corrosion on the bolts:</p> <ol style="list-style-type: none"> 1. Inspect both driver and passenger outboard seat track bolts on each seat track for rust. 2. Replace 1 to a maximum of 4 rusted outboard seat track bolts. <p>Can claim with labor combination operations 25S92EE (Coupe) or 25S92FF (convertible). This labor operation does not close FSA 25S92.</p>	<p>25S92D</p> <p>0.4</p>
<p>Ford Vehicle Pick-Up & Delivery Allowance: This allowance is only for <u>non-eligible</u> 2026 Remote Experience Program Dealers. NOTE: This allowance is for dealer-performed vehicle Pick-Up & Delivery for dealership repairs only. Can only be claimed once, regardless of outstanding FSAs repaired.</p>	<p>25S92PP</p> <p>0.5</p>
<p>Time allowed to submit photos. If VOR is required and vehicle must be present in dealership to complete repair:</p> <ol style="list-style-type: none"> 1. Attach a photo or clearly show and upload the open repair order (RO). 2. Attach a photo of door tag showing the VIN plate. 3. Attach a photo of vehicle odometer current mileage. 4. Attach photos of a rust/corrosion of seat belt pretensioner(s) or surrounding components, per the Technical Instructions. 5. If the vehicle is off road, then refer to EFC14236. VOR escalation is required in DOW. 	<p>25S92ZZ</p> <p>0.2</p>

PARTS REQUIREMENTS / ORDERING INFORMATION

Regular Part Ordering: Inspection is required. See Technical Instructions.

Order your parts through normal order processing channels. To guarantee the shortest delivery time, an emergency order for parts must be placed.

Safety Recall 25S92

PARTS REQUIREMENTS / ORDERING INFORMATION (Continued)

Service Part Number	Claim Quantity	Package Order Quantity	Number in Package	Description
W718717 - S300	2	1	4	A-Pillar Rubber Body Plug
Miscellaneous – Obtain Locally				
Painter’s Masking Tape – 6654 -3M. One roll of yellow automotive refinish masking tape (Or equivalent) as needed (One roll of tape services multiple vehicles)				Claim as Misc. Other Up to \$35.00 Total Assumes most products can be used multiple times For Repairs and Interim repairs that are needed
Isopropyl Alcohol Wipes - Rotunda Part # CSU460. 1-Box of Chaos Safety Supplies Alcohol Wipes (or equivalent) as needed (One box of alcohol wipes services multiple vehicles)				
Anti-corrosion sealer - Motorcraft® anti-corrosion PM-13-B (or equivalent) as needed (One bottle of anti-corrosion sealer services multiple vehicles)				
Touch-Up paint pen - Motorcraft® touch-up Paint (VIN Specific part number. Use parts catalog with base part # -19500- to search for the correct touch-up paint pen color application) (or equivalent) (One touch-up pen services multiple vehicles)				

Restricted Part Ordering:

PARTS REQUIREMENTS / ORDERING INFORMATION

Restricted Part Ordering:

Inspection Required Inspection is required, refer to FSA 25S92 Technical Instructions to obtain approval from SSSC on replacement of outboard seat track bolt(s).

To place an order for K-Coded outboard seat track bolt(s), submit a VIN-specific Part Order contact via the SSSC Web Contact Site.

If parts are on back order, vehicle must be present in the dealership. The VIN-specific part order must provide the following:

1. Attach a photo of vehicle mileage.
2. Attach a photo of door tag showing VIN.
3. If the vehicle is off road, then refer to EFC14236. VOR escalation is required in DOW.

Service Part Number	Claim Quantity	Package Order Quantity	Number in Package	Description
W715925 - S437M	up to 4	1	4	Outboard - seat track bolt(s) (as required)

Dealers will be notified via a DOES II communication if circumstances warrant a change in part supply strategy and when open ordering resumes.

Safety Recall 25S92

PARTS REQUIREMENTS / ORDERING INFORMATION (continued)

If other services are requested on the same RO, please complete them. Once they are completed, and if the customer elects to take delivery of their vehicle while waiting for parts to arrive to complete this program, dealers should close the repair order. Reference to W&P manual section 1.3.09 for detailed information associated with these applicable process steps.

DEALER PRICE

For the latest prices, refer to DOES II.

PARTS RETENTION, RETURN, & SCRAPPING

Please refer to the FSA Policy Document for any and all questions on parts.

EXCESS STOCK RETURN

Please refer to the FSA Policy Document for any and all questions on parts.

REPLACED FSA PARTS INSPECTION AND SIGN OFF

Please refer to the FSA Policy Document for any and all questions on parts.

CERTAIN 2015-2017 MODEL YEAR MUSTANG VEHICLES — SEAT BELT ANCHOR PRETENSIONER INSPECTION

SERVICE PROCEDURE

IMPORTANT! The Service Technician Specialty Training (STST) Competency 10 certification requirement in the U.S. market only will be enforced starting with repair orders opened on or after August 31, 2024. Field Service Action (FSA) repairs will reject and the claim will not be paid if the repairing technician is not certified in STST Competency 10 FSA. See Electronic Field Communication (EFC) 15936 for more details.

NOTE: Flow Chart is a high level overview only. Read ALL technical instructions for full detail.

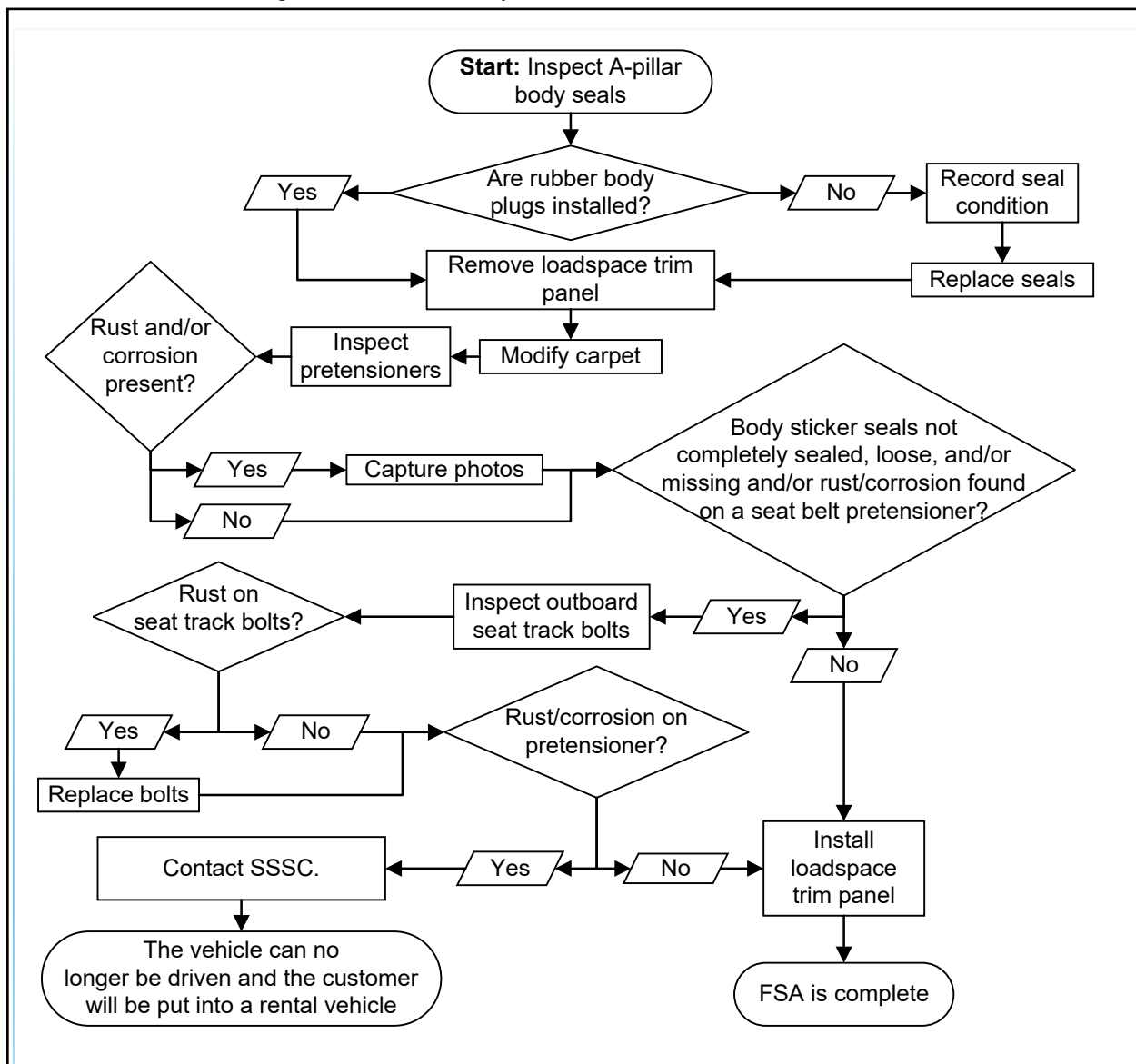

1. On both sides, fully open the front doors.
2. On both sides, inspect the A-pillar body hole. See Figure 1.

- Are rubber body plugs present in the A-pillar body holes?

Yes - Rubber body plugs are present in the A-pillar body holes. Proceed to Step 11.

No - Body sticker seals are present in the A-pillar body holes. Proceed to Step 3.

NOTE: Left hand (LH) side shown, right hand (RH) side similar.

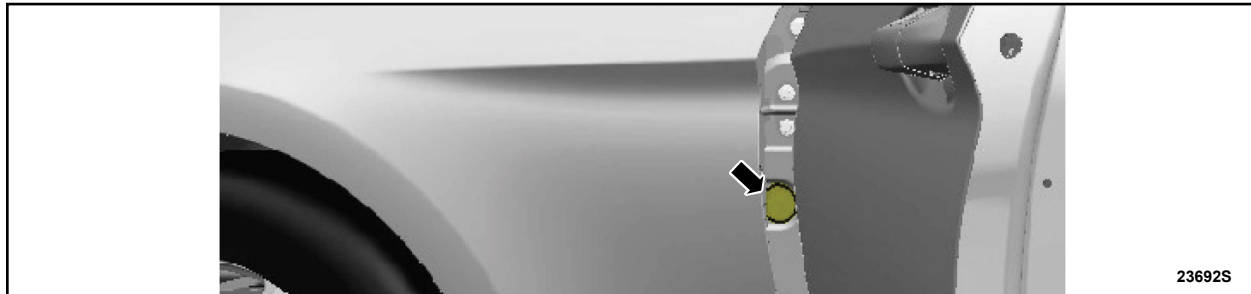

FIGURE 1

3. On both sides, inspect the fender insulator to be sure it does not restrict access to the A-pillar body sticker seal. If the fender insulator covers any portion of the A-pillar body sticker seal, the foam fender insulator can be slightly indented to allow for unobstructed access to the A-pillar body sticker seal.
4. On both sides, inspect and record the condition (complete 360-degree adhesion to the sheet metal, loose and/or missing) of the A-pillar body sticker seal. See Figure 2.

NOTE: The A-pillar body sticker seals are an adhesive patch that seals a 19 mm (0.75 in.) diameter hole in the sheet metal.

NOTE: Loose A-pillar body sticker seals shown.

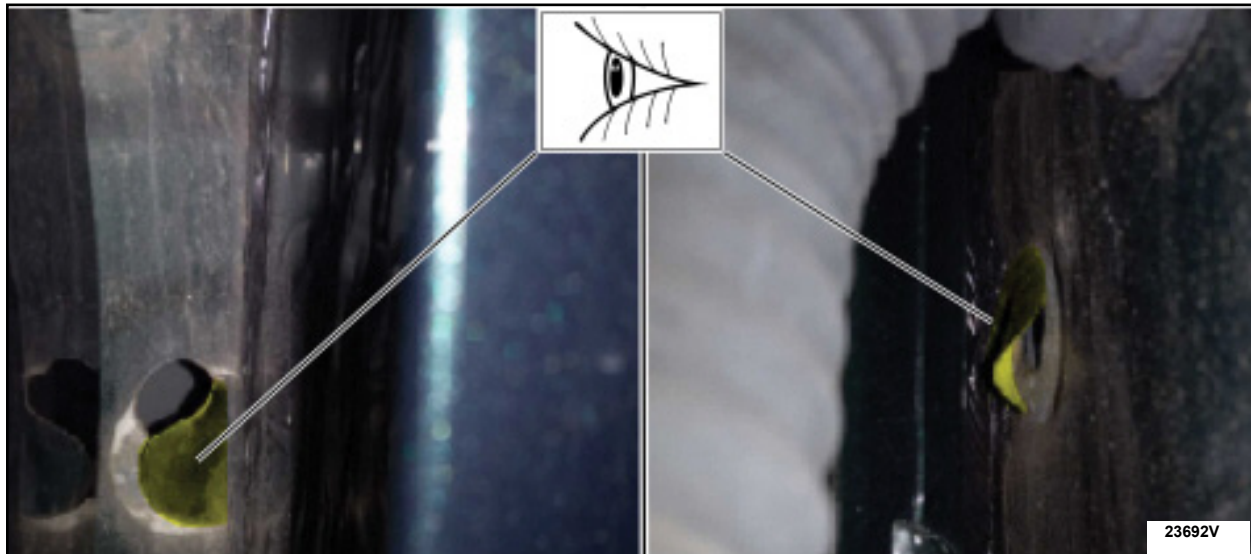

FIGURE 2



5. On both sides, apply paint-safe, protective tape to the door and fender edges.
 6. On both sides, use fingers and/or pliers to completely remove and discard the A-pillar body sticker seal. See Figures 1 and 2.
 7. On both sides, use alcohol wipes to remove all remaining adhesive left by the discarded A-pillar body sticker seal.
 8. On both sides, apply Motorcraft® Anti-Corrosion Coating to all exposed metal around both A-pillar body holes and allow to dry following the instructions on the container.
 9. On both sides, use a small paint brush to apply touch-up paint to the exterior surfaces that were previously coated with Motorcraft® Anti-Corrosion Coating. Allow the paint time to dry following the instructions on the touch-up paint container.
 10. On both sides, install and fully seat a new rubber body plug into the A-pillar body hole.
- NOTE:** There will be two rubber body plugs installed per vehicle.
11. On both sides, remove the loadspace trim panel. Follow Workshop Manual (WSM) procedures in Section 501-05.
 12. On both sides, apply tape to the carpet in the area shown. See Figure 3.

NOTE: LH side shown, RH side similar.

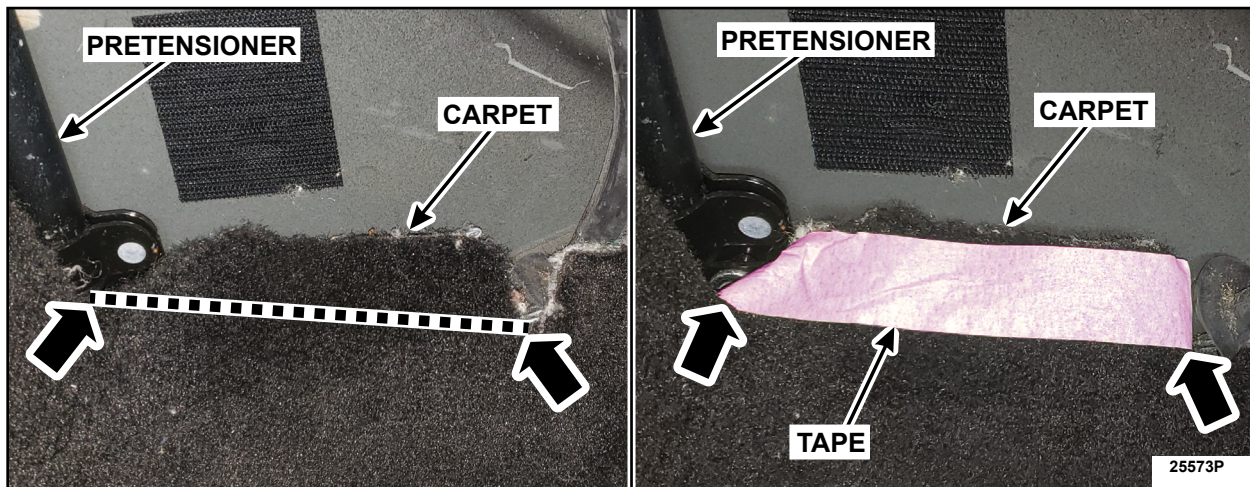

FIGURE 3



13. On both sides, carefully cut the carpet along the tape (1). Remove and discard the cut section of carpet (2). See Figure 4.

NOTE: LH side shown, RH side similar.

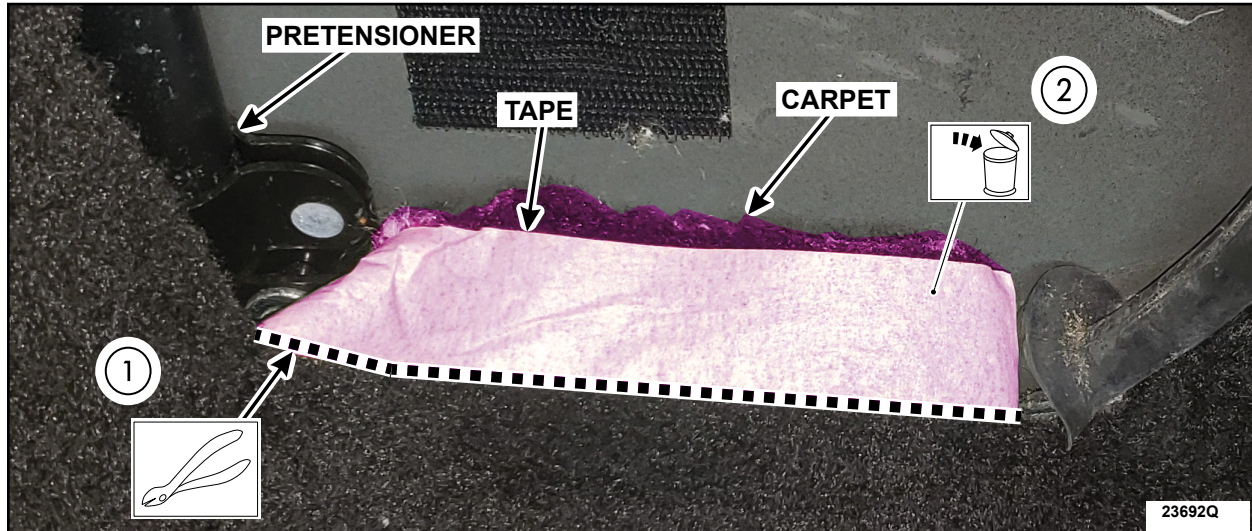

FIGURE 4

14. In the specified carpet section, position the carpet and remove and discard the foam insulation from the underside on both sides of the vehicle. See Figure 5.

NOTE: It is possible to remove the foam insulation by hand by pulling it off the underside of the carpet.

NOTE: LH side shown, RH side similar.



FIGURE 5



15. On both sides, visually inspect the steel braided cable on the seat belt pretensioner and the surrounding area for signs of rust and/or corrosion. See Figures 6-9.

- On either side, is red rust present on the steel braided cable of the seat belt pretensioner and/or a significant amount of corrosion present on the surrounding components?

Yes - Red rust is present on the steel braided cable of the seat belt pretensioner and/or a significant amount of corrosion is present on the steel braided cable and/or surrounding components - Does not pass inspection - Proceed to Step 16.

No - There is no red rust present on the steel braided cable of the seat belt pretensioner and there is not a significant amount of corrosion present on the steel braided cable and/or surrounding components - Passes Inspection - Proceed to Step 17.

NOTE: RH side shown, LH side similar.



FIGURE 6

NOTE: A small amount of white dusty surface rust on the steel braided cable and surrounding components is acceptable. See Figure 7.

NOTE: RH side shown, LH side similar.



FIGURE 7



NOTE: Any amount of red rust on the steel braided cable is NOT acceptable and does not pass inspection. See Figure 8.

NOTE: RH side shown, LH side similar.

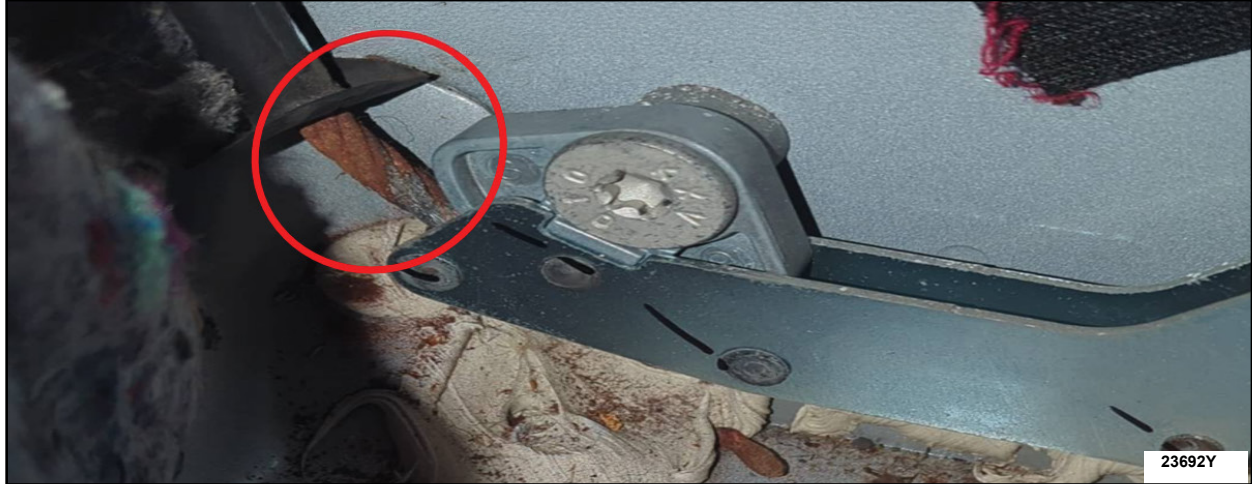

FIGURE 8

NOTE: A significant amount of white rust on the steel braided cable and/or surrounding components is NOT acceptable and does not pass inspection. See Figure 9.

NOTE: RH side shown, LH side similar.



FIGURE 9



16. Capture a clear photo of the red rust that is present on the steel braided cable of the seat belt pretensioner(s) and/or the significant amount of corrosion that is present on the steel braided cable(s) and/or surrounding components.

NOTE: Make sure there is adequate lighting when capturing the clear image of the steel braided cable on the seat belt pretensioner.

17. Did the inspections in Step 4 and Step 15 reveal ANY of the following conditions:

- An A-pillar body sticker seal with incomplete 360-degree adhesion to the sheet metal.
- An A-pillar body sticker seal that was loose.
- An A-pillar body sticker seal that was missing.
- Red rust present on the steel braided cable of the LH and/or RH seat belt pretensioner.
- A significant amount of corrosion present on the steel braided cable of the LH and/or RH seat belt pretensioner and/or surrounding components.

Yes - Proceed to Step 18.

No - Proceed to Step 22.

18. On both sides, remove the front seat outboard shield bolt caps. See Figure 10.

NOTE: LH side shown, RH side similar.

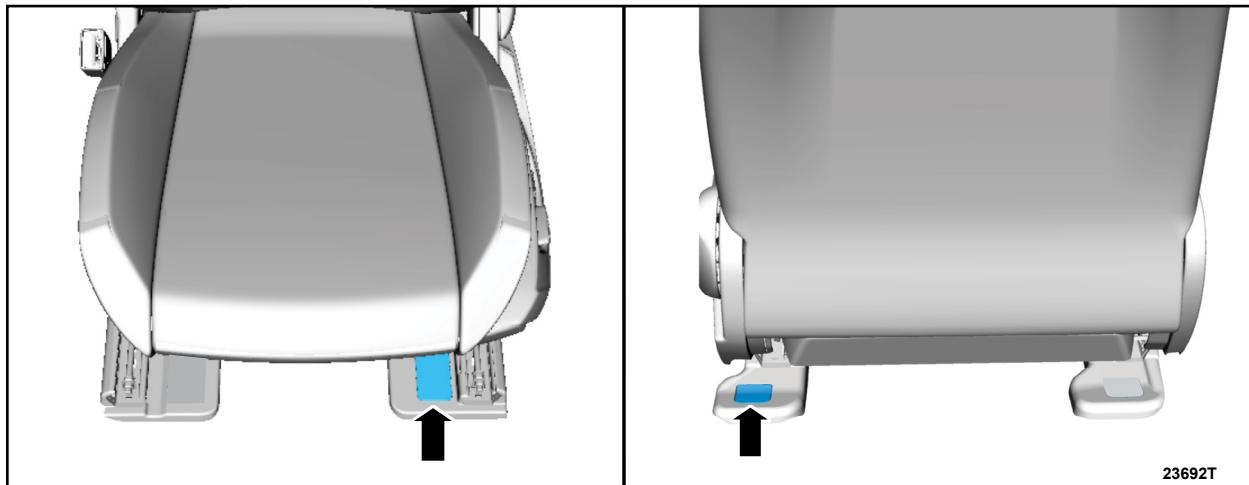

FIGURE 10



19. On both sides, inspect the outboard seat track bolts for rust.

- Is red rust present on the lower surface of the bolt and seat track bracket mounting surface? See Figure 11.

Yes - Does not pass inspection - Proceed to Step 20.

No - Passes Inspection - Proceed to Step 21.

NOTE: On the LH side seat, the bolts being inspected for rust are the left front and the left rear outboard seat track bolts. On the RH side seat, the bolts being inspected for rust are the right front and the right rear outboard seat track bolts.

NOTE: Front LH side outboard seat track bolt (1) shown on left, Rear RH side seat track bolt shown (2) on right, all others similar.

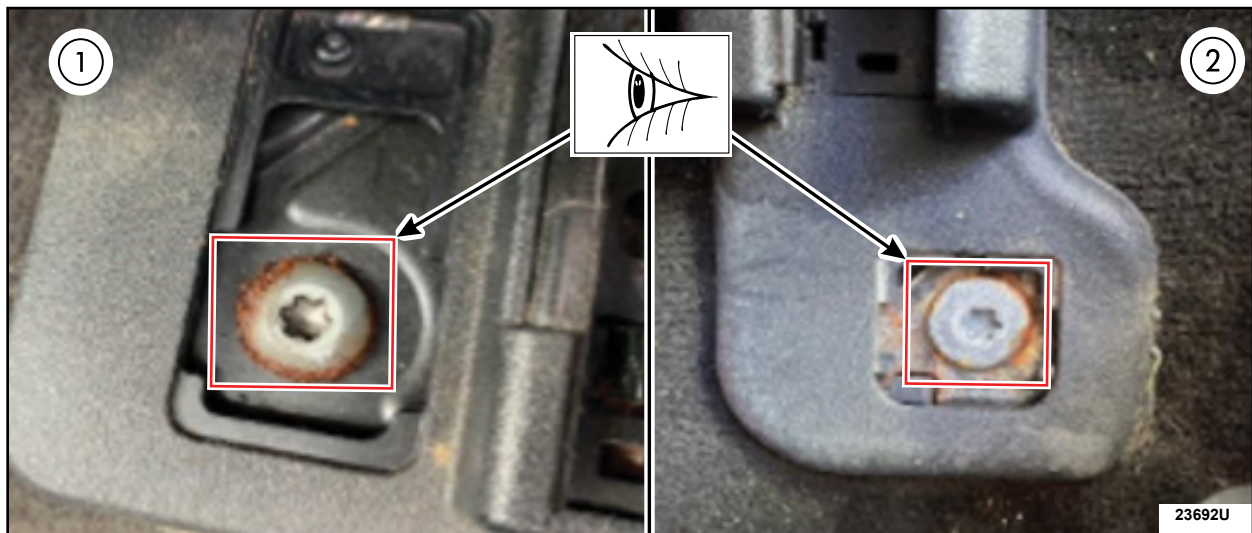

FIGURE 11

20. Only replace the affected outboard seat track bolt(s) one at a time.

• Torque: 35 lb.ft (47 Nm)

NOTE: It may be necessary to replace up to 4 (four) bolts in total.

21. On both sides, install the front seat outboard shield bolt caps. See Figure 10.

22. Did the inspection in Step 15 reveal, on the LH and/or RH side, red rust on the steel braided cable of the seat belt pretensioner and/or a significant amount of corrosion present on the surrounding components?

Yes - Contact the Special Service Support Center (SSSC). Proceed to Page 9.

No - Proceed to Step 23.

23. On both sides, install the loadspace trim panel. Follow WSM procedures in Section 501-05.



PHOTO REQUEST SUBMISSION (SSSC PHOTO SUBMISSION)

Ford has requested photo evidence, if the inspection reveals rust/corrosion on the seat belt pretensioners components, per the Technical Instructions for this FSA. The Special Service Support Center (SSSC) must provide approval prior to performing the repair.

The SSSC must provide approval prior to performing further repair.

1. Contact the SSSC, submit an Approval Request to the SSSC web contact site, and upload the necessary photos or copy of documentation as an attachment for review. A total of 4 to 6 photos will be needed, these should include:

- Open Repair order (RO): A clear image of the physical or digital RO.
- Vehicle Identification Number (VIN) Plate: Located on the left-side (LH) door jamb
- Odometer: Showing the vehicle's current mileage.
- Rust/Corrosion Evidence: Clear image(s) showing red rust on the steel braided cable of the seat belt pretensioner(s) and/or significant corrosion on the surrounding components on either side.

2. There are two ways to submit the requested items to SSSC.

- a. Directly in the SSSC contact request form while submitting your contact on your computer.
- b. Via PTS Mobile under the Images/Files Upload menu selection. Select SSSC in the sub-menu and make sure your P&A code is correct. Upload the items by selecting the appropriate FSA with the option to use a prior contact ID. The items will be associated with your SSSC contact during submission.

NOTE: If you have not submitted an SSSC contact yet, then you can still upload the items via PTS Mobile, and the items will be available when opening your SSSC contact for this VIN and recall.

3. Upon review of the seat belt anchor pretensioner image(s), the SSSC confirmed the presence of red rust on the steel braided cable of the seat belt pretensioner(s) and/or a significant amount of corrosion is present on the surrounding components on one or both sides of the pretensioner(s). **The vehicle can no longer be driven.** The SSSC will instruct the dealer to put the customer in a rental vehicle. Once the revised Dealer Bulletin is released, with the available parts, the replacement of the front seat belt retractor and pretensioner will be required.

NOTE: The vehicle can remain disassembled at this time.

4. Upon approval, the SSSC will provide an approval code for rentals. Refer to the Dealer Bulletin rental sections for claiming.

IMPORTANT NOTE: Federal law prohibits selling motor vehicle parts or components that are under safety, compliance, or emissions recall. Unless a part is requested to be returned to Ford, all parts replaced under this FSA must be scrapped in accordance with all applicable local, state and federal environmental protection and hazardous material regulations. Refer to the Parts Retention, Return, & Scrapping section of the FSA dealer bulletin for further information.



Ford Motor Company
Recall Reimbursement Plan for 25S92

Ford and Lincoln dealers are in the best position to quickly and efficiently process reimbursement requests. However, federal legislation requires all motor vehicle manufacturers to establish processes through which customers may seek recall reimbursement directly from the manufacturer or the dealers.

Regarding the specific reimbursement plan for Recall # 25S92, owners who have paid for service to remedy the defect or noncompliance must have had that service performed before June 30, 2026. After this date, if repairs related to this recall are performed by a non-Ford repair facility in an emergency, customers must submit any refund requests through their dealership. As required by this federal regulation, Ford Motor Company submitted the details of its latest General Recall Reimbursement Plan in a letter to the National Highway Traffic Safety Administration (NHTSA) in May 2025. The following is the text of that letter and the Plan:

General Recall Reimbursement Plan
(As submitted to the NHTSA)

Pursuant to the requirements set forth in 49 CFR Part 573 and Part 577 of the Code of Federal Regulations, Ford Motor Company (Ford) is submitting required information pertaining to our general reimbursement plan for the cost of remedies paid for by vehicle owners before they are notified of a related safety recall.

Set forth below is Ford's general plan to reimburse owners and purchasers for costs incurred for remedies in advance of notification of potential safety-related defects or non-compliances pursuant to Part 573.6 (c)(8)(i). This plan has not changed since our May 21, 2025 submission.

Reimbursement Notification

Ford's notice to a vehicle owner in accordance with 49 CFR Part 577 will indicate that Ford is offering a refund if the owner paid to have service to remedy the defect or noncompliance prior to a specified ending date. In accordance with Part 573.13 (c)(2), this ending date will be defined as a minimum of ten calendar days after the date on which Ford mailed the last of its Part 577 notifications to owners and will be indicated in the specific reimbursement plan available to owners for an individual recall. This notice will direct owners to seek eligible reimbursement through authorized dealers or, at their option, directly through Ford at the following address:

Ford Motor Company
P.O. Box 6251
Dearborn, MI 48121-6251

Ford notes that this rule allows for the identification of a beginning date for reimbursement eligibility. Under the rule, an owner who paid to remedy the defect or noncompliance prior to the identified beginning date would not be eligible for reimbursement. Ford generally has not established such a beginning date for reimbursement eligibility and does not presently anticipate changing this general policy. However, in any case where Ford determines a beginning date is appropriate, Ford will indicate that date in the owner notice. As permitted by 577.11(e), Ford may not include a reimbursement notification when all vehicles are well within the warranty period, subject to approval by the Agency.

Costs to be Reimbursed

For vehicles, reimbursement will not be less than the lesser of:

- The amount paid by the owner for the remedy that specifically addressed and was reasonably necessary to correct the defect or noncompliance that is the subject of the recall, or
- The cost of parts for the remedy (to be no more than the manufacturer's list retail price for authorized part(s), plus associated labor at local labor rates, miscellaneous fees (such as disposal of waste) and taxes.

For replacement equipment, reimbursement will be the amount paid by the owner for the replacement item (limited by the amount of the retail list price of the defective or noncompliant item that was replaced, plus taxes, where the brand or model purchased by the owner was different than the brand or model that was the subject of the recall). If the item of motor vehicle equipment was repaired, the reimbursement provisions identified above for vehicles will apply.

Ford notes that costs incurred by the owner within the period during which Ford's original or extended warranty would have provided for a free repair of the problem will not be eligible for reimbursement, as provided by Part 573.13 (d)(1).

Entities Authorized to Provide Reimbursement

Ford will continue to use authorized dealers to reimburse owners under the specific reimbursement plans for a particular recall and will encourage owners to pursue requests for reimbursement directly through dealers to expedite reimbursement. Ford will also provide a mailing address to which customers can, at their option, send requests for reimbursement directly to Ford, as previously noted. Requests for reimbursement sent directly to Ford may take up to 60 days to process. Whether the owner chooses to pursue reimbursement requests through a dealer or directly through Ford, the owner will be directed to submit the required documentation, upon which reimbursement eligibility will be determined.

Required Documentation

The reimbursement determination will depend upon the information provided by the customer. Consistent with Part 573.13 (d)(4) the following information must be submitted:

- Claimant name and address
- Vehicle make, model and model year
- Vehicle identification number (VIN) and, for replacement equipment, a description of such equipment or, for tires, the model, size and TIN (DOT code)
- Identification of the recall number (either the Ford recall number or the NHTSA recall number)
- Identification of the owner of the recalled vehicle at the time that the pre-notification remedy was obtained
- An original receipt for the pre-notification remedy that includes a breakdown of the amount for parts, labor, other costs and taxes, including costs for the replacement item. Where the receipt covers work other than to address the recall or noncompliance, Ford may require the claimant to separately identify costs that are eligible for reimbursement.
- If the remedy was obtained during the warranty repair did not correct the problem related to the recall

Failure to submit all the above information may result in denial of the reimbursement request.

Additional Information

The Part 577 required owner notice will provide a toll-free telephone number through which specific information about the reimbursement plan can be requested from Ford. This general reimbursement plan will be incorporated into notifications pursuant to Part 573.6 by reference. Information specific to an individual recall also may be incorporated into the Part 573.6 notification.