



Storyteller Overland, LLC
Customer Service Department
428 Industrial Lane
Birmingham, AL 35211

April 2025

TO: Storyteller Overland, LLC Dealers
Subject: NHTSA Recall: 25V-070

Storyteller Overland, LLC (“Storyteller”) has decided that certain 2024-2025 Storyteller Overland MODE XO vehicles may fail to comply with FMVSS 207, “Seat Systems”. All MODE XO’s subject to the recall were manufactured prior to 01/24/2025. Storyteller has notified MODE XO owners of this recall, and MODE XO owners are already reaching out to Storyteller Dealers to schedule repairs. DO NOT DELIVER TO A CUSTOMER ANY MODE XO VEHICLES SUBJECT TO THIS RECALL UNTIL CORRECTIVE ACTION HAS BEEN TAKEN.

What is the reason for this recall? Storyteller Overland, LLC has determined that certain Storyteller Mode XO vehicles may not comply with FMVSS 207 seat pull testing requirements, as it was determined by Storyteller's supplier that the seat assembly's floor mounting system may contain manufacturing defects.

What is the risk? If seat assemblies do not meet FMVSS 207 pull testing requirements, the risk of injury increases during an accident.

What is the fix? Please see the instructions attached to this letter for repair instructions and required parts. Please coordinate with STO's Customer Service Department to ensure required parts have been shipped to you in time for each MODE XO owner's appointment. When the service has been completed, please submit the checklist provided to Storyteller via email to service@storytelleroverland.com. Please contact Storyteller should you have any questions or need any assistance with these instructions.

Dealers are to service all vehicles subject to this campaign at no charge to owners regardless of mileage, age of vehicle, or ownership from this time forward. Storyteller will reimburse your service department for the labor time set forth in the repair instructions.

Thank you for your prompt attention to this important matter.



MODE XO Seat Recall

Rev03062025

Overview:

The following are instructions for replacement of the MODE XO seat mounting brackets and seat slide mounting washer plate. Complete the attached checklist "03062025 Recall # 25V070 XO Seat Recall Checklist" along with these instructions and provide a signed, completed copy to service@storytelleroverland.com.

Applicable Vehicles:

ALL MODE XOs produced prior to 01/24/2025

Safety Alert:

All work completed under the scope of this recall must be performed by qualified individuals. The following procedure requires work under the van where vehicle components could be hot. Only perform these steps once the van has had adequate time to cool down and is set up in a safe location. The work contained in these steps involve safety critical components to the vehicle and therefore must follow the procedure contained here. Reach out to Storyteller Overland should you have any questions or concerns.

Flat Time: 16 hours (2 people, 8 hours)

Supplies Needed:

- (1) Updated MODE XO Underbody Seat Bracket*
- (2) Updated MODE XO Seat Bracket Top Plates*
- (1) 1 1/2" x 1 1/2" Hub x Hub ABS coupling*
- (2) 1 1/4" x 1 1/2" PVC Bushing Adapter *
- (2) Seat Slide Mounting Washer Plates*
- (1) 5/16"-18 X 1.50" Zinc-plated Hex Head Bolt*
- (2) Luan Wood Shims M4W-17-00-003-1.1*
- (23) 1/2"-13 Nylon Lock Nuts*
- (15) Zip Ties*
- All Purpose Plumbers Cement for PVC and ABS (Oatey #30834)
- Seal Bond 105
- OSI Quad Max

* indicates items to be provided for the repair



Tools Needed:

- | | |
|--------------------------------|-----------------------------------|
| Impact Driver | Flat Head Screwdriver |
| #2 Philips Bit | T-30 Torx Bit |
| Torque Wrench (102 NM & 56 NM) | E16 External Torx Socket |
| 1/8" Allen Key | 12" Extension |
| 5/16" Deep Well Socket | 9/16" Socket & Combination Wrench |
| Ratchet Handle | Hose cutters |
| 3/4" Socket | Flush Cutters |
| 90° Electric Ratchet | Floor Jack |
| 1/2" Combination Wrench | |

Repair Procedure:

1. Inspect.

a. Inspect the entire unit for any damage prior to beginning repairs. Review findings with customer and note on the checklist

2. Remove the fridge from galley.

a. Start by removing the top (2) drawers from galley and set aside.

b. Prior to disconnecting the fridge, fridge will need to go through a defrosting stage and content removed or needs to be connected to a separate 12v power supply once out of van.

c. Disconnect (2) spade connections on the backside of the fridge. **Note: some models will also have 110 power cable that is taped to the backside of fridge this will need to be disconnected from an internal galley 110 receptacle prior to removing the fridge.** (See Figure 1 and 2)

d. Open the fridge door and take a phillips bit screw driver and 1/8" allen key to remove the (4) screws that are securing the fridge to the galley. Retain all hardware once removed. (#10-24 x 1" SS barrel nut, 1/4" PVC washer, #10-24 x 1.25" Flat Head Screw and aluminum counter sunk washer. (See Figure 3)

e. Slightly lift up on the fridge then carefully slide the fridge forward, towards the front of the van and remove to set out of the way. (See Figure 4) **Note: be very cautious to not damage the floor trim when removing the fridge.**

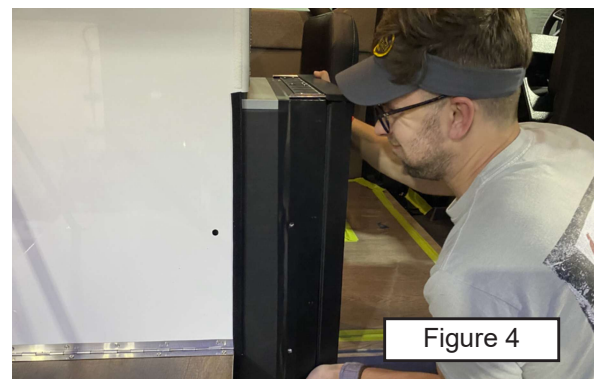
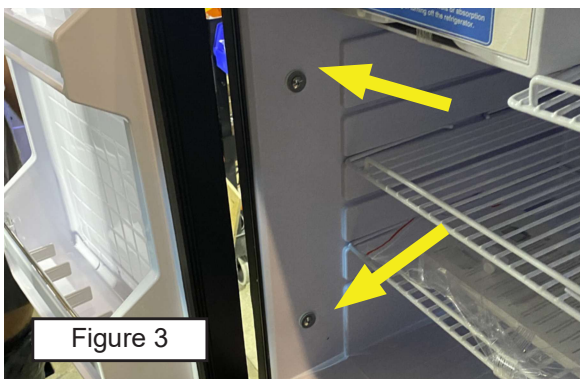
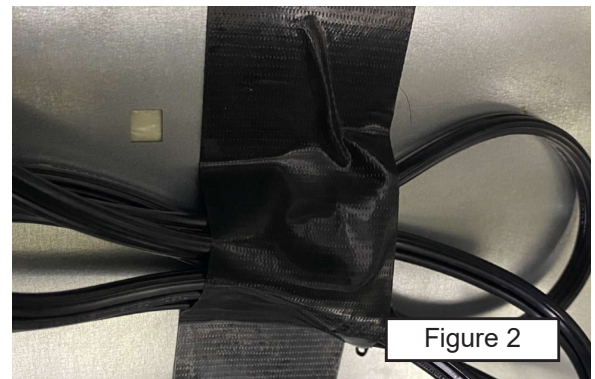
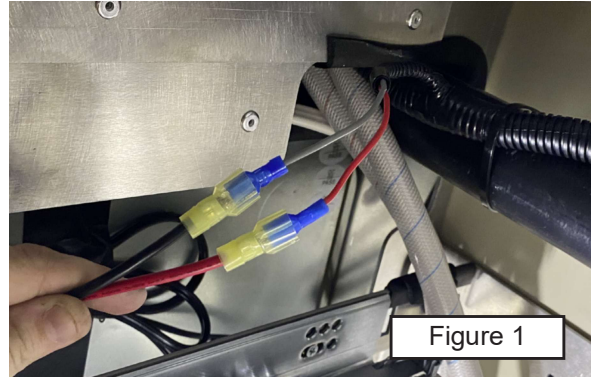

3. Remove XO Seat Shroud

a. Slide the XO seat forward to access the top plate of the seat shroud to remove the (3) wafer head wood screws securing the black angled trim to the front face of the shower wall. Next remove the (3) wafer head self tapping screws that go through the top of the plate and into the bracing below the panel. (See Figure 5)

b. With the (3) wafer head screws removed, rotate the top plate up and disconnect the (2) loomed cables, then pass the (2) loomed cables back through the top of the seat shroud. Carefully remove the top plate and set out of the way. (See Figure 6)

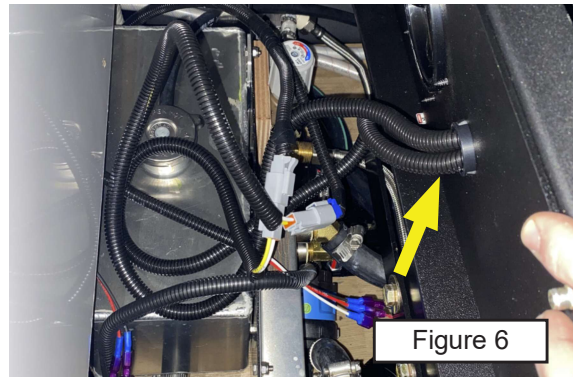
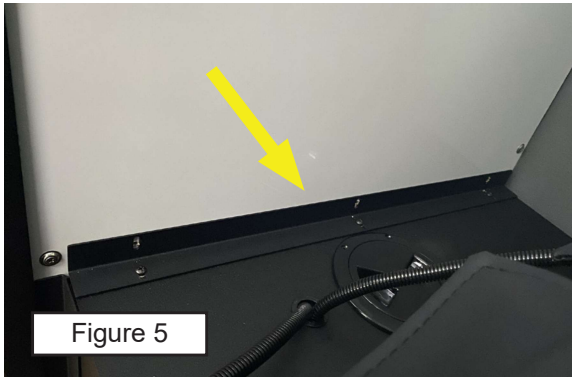

c. Use a 5/16" socket to disconnect the hose clamp for the air duct inside of the seat shroud.

d. Remove the (2) wafer head screws from the front and (1) wafer head screw from the side of the lower seat shroud panels. (See Figure 7 & Figure 8)

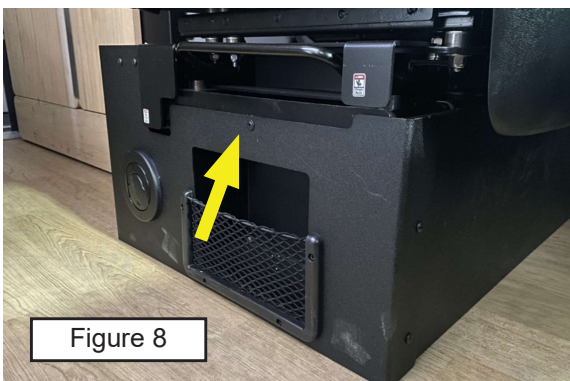
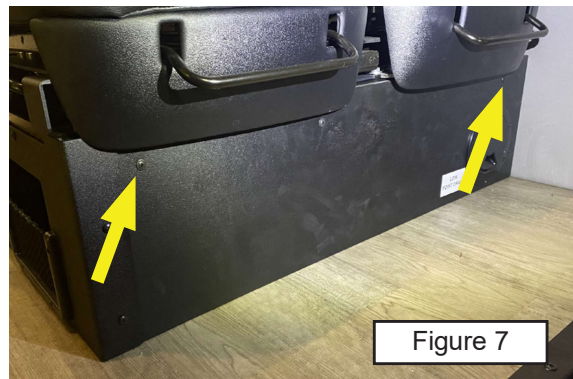

e. Carefully slide the seat shroud assembly away from the seat and set outside the van. (Figure 9)

f. Next remove the screws that are securing the air handler to the floor between the seat legs. (Figure 10)

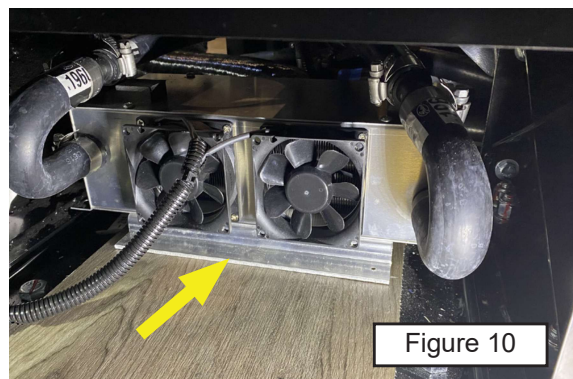

4. Remove XO Seat

- a. Use a 3/4" socket/wrench to remove the (8) 1/2" nylon lock nuts and (8) 1/2" SAE washers that secure the seat base to the floor brackets. (See Figure 11 and Figure 12) **Note: the nylon lock nuts will need to be replaced with new ones when the seat is reinstalled into the van.**
- b. Once the (8) 1/2" nylon lock nuts are loose, carefully remove the seat from the van making sure not to damage any of the floor or surrounding area.

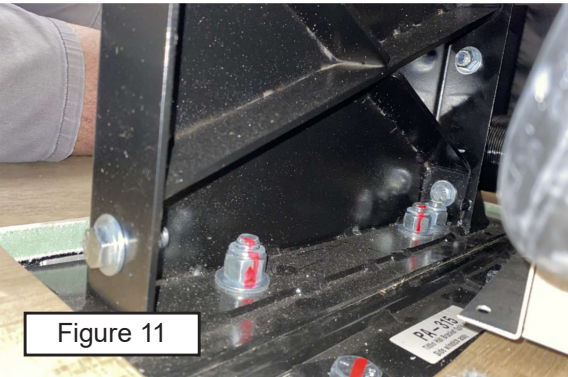

5. Repair XO Seat

- a. With the seat removed from the van, use a 1/2" combination wrench and flat blade screwdriver to remove the bolt holding a gold U bracket from the inside seat, left rear track. (See Figure 13) **Note: It is easiest to access this bolt with the inside seat slid all the way forward and sideways away from the other seat.**
- b. Once the U bracket is removed replace with (2) flat bar spacers. (See Figure 14) Position the (2) spacer in the track, from the back side of the seat, then reuse the existing nylon lock nut and bolt to secure the (2) flat bars in place. (See figure 15) **Note: the gold U bracket will no longer be used and can be discarded.**

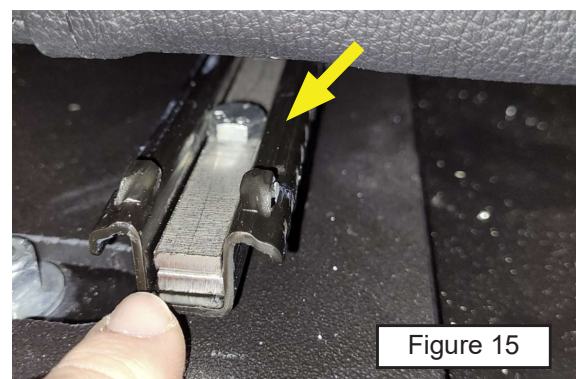
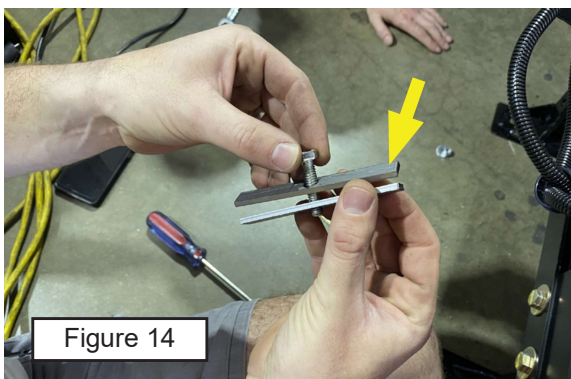
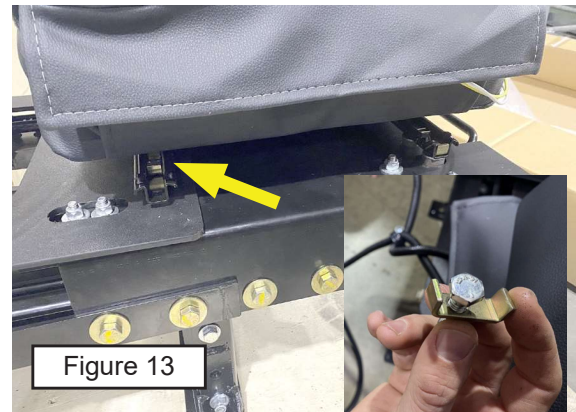

6. Remove Grey Tank

- a. Make sure the content of grey tank has been emptied prior to performing service.

b. On the top inboard side of the grey tank disconnect the fitting for the hepvo valve at the elbow below the shower drain. In the same area on top of the grey tank, disconnect the deutsch connector for the tank sensor. (See Figure 16)

c. Use a 5/16" socket/wrench to loosen the hose clamp on the grey ribbed macerator hose then carefully remove the ribbed hose from the 90° fitting. (See Figure 17) **Note: this connection has silicone to seal the hose to the fitting. The hose will need to be carefully twisted, pulled and/or pried off of the barbed fitting. When prying, make sure to not damage the hose, fitting or tank.**

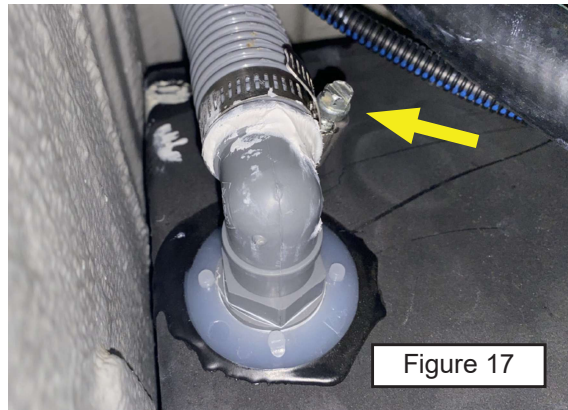
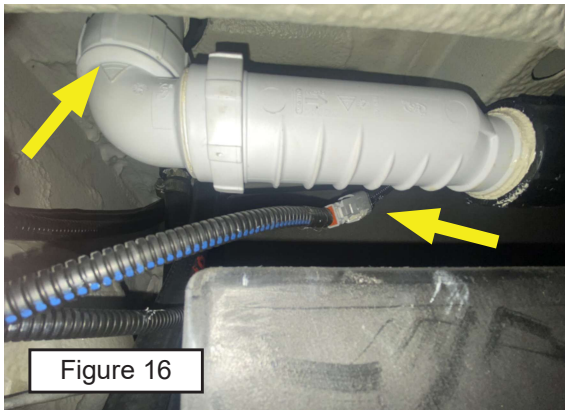

c. Position a floor jack under the grey tank pan to help support the tank assembly while the plumbing and hardware are removed.

d. Once the tank is supported, use the 9/16" socket to remove the (8) 3/8" x 1/2" hex head bolts and 3/8" flat washers along the bottom, sides of the grey tank bracket. (See Figure 18)

e. Use flush cutters to cut the zip tie holding the 1/4" rixen furnace fuel line to the fuel filler tube, at the front of the fuel tank and the zip ties that are holding the coolant lines on the side mounting brackets of the grey tank pan.



f. On the Inside of the van use a pair of hose cutters to carefully cut the grey tank vent hose at approximately 2-3" below the white shower finish panel as shown. (See Figure 19)

g. Once grey tank vent hose has been cut from the inside of the van, carefully lower the grey tank down and out of the way. (See Figure 20)

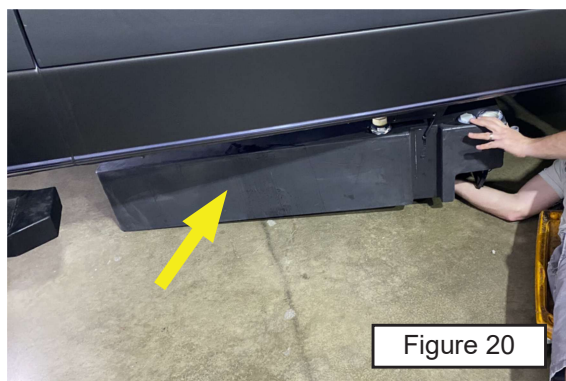

7. Remove The Fuel Tank

- a. Open the fuel door and use a T-30 torx bit with an extension to remove the (4) bolts securing the fuel filler neck housing. (See Figure 21)
- b. Next loosen the (2) bolts holding the fuel door hinge, to the van, then rotate the fuel door enough to remove the fuel filler neck housing and set the hardware to the side.
- c. Once the shroud has been removed, use the same T-30 torx bit to remove the single screw holding the filler neck in place. (See Figure 22)
- d. Disconnect the fuel cap tether from the fuel door and reinstall the fuel cap back on the filler neck to prevent any fuel being spilled during the repair process.

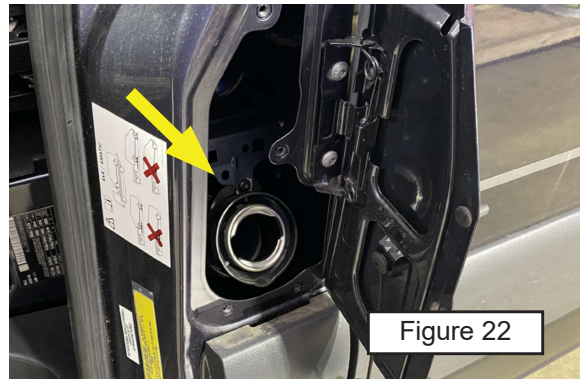
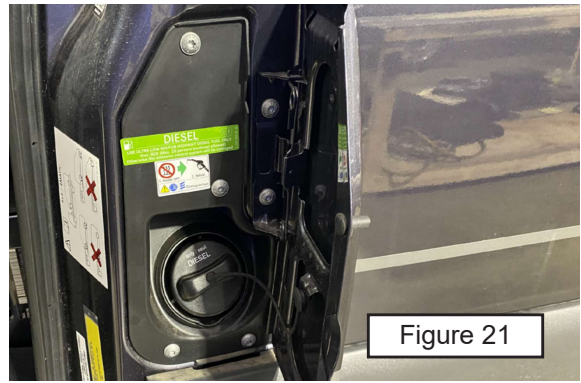

- e. Use the E16 socket to remove the (2) bolts holding the center fuel tank strap. (See Figure 23)
- f. Reposition the jack back under the van and centered under the fuel tank. With the jack in place, remove the (2) bolts holding all (3) the fuel tank straps. (See Figure 24) **Note: retain all hardware and tank strap brackets, these will be needed when reinstalling the fuel tank.**
- g. With the (3) fuel tank straps removed slowly lower the tank down while paying attention to the fuel line mounting points, disconnecting the fuel lines from the chassis mounting points as needed to lower the tank until it is supported by a stand (such as a pallet). **NOTE: The fuel tank needs to remain supported off the floor with a stand to prevent having to disconnect the fuel lines and to prevent damage the lines during the repair process.**

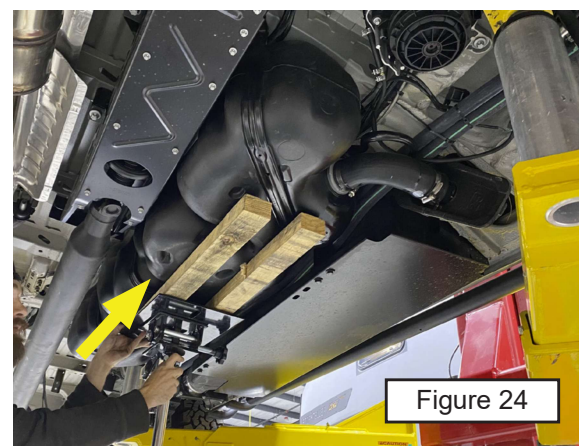
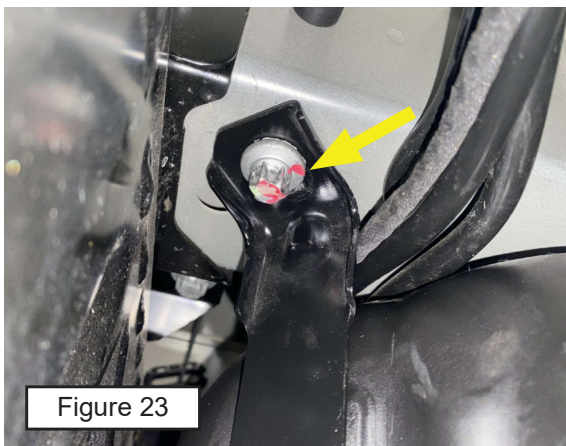

8. Remove The Lower Seat Bracket

a. Start by using flush cutters to cut any zip ties securing the harness to the lower seat bracket, then removing the brake lines from the (2) clips that are mounted on the bracket. (See Figure 25)

b. Next remove the brake lines from the clips that are mounted to the frame rail directly in front and behind the lower seat bracket. (See Figure 26)

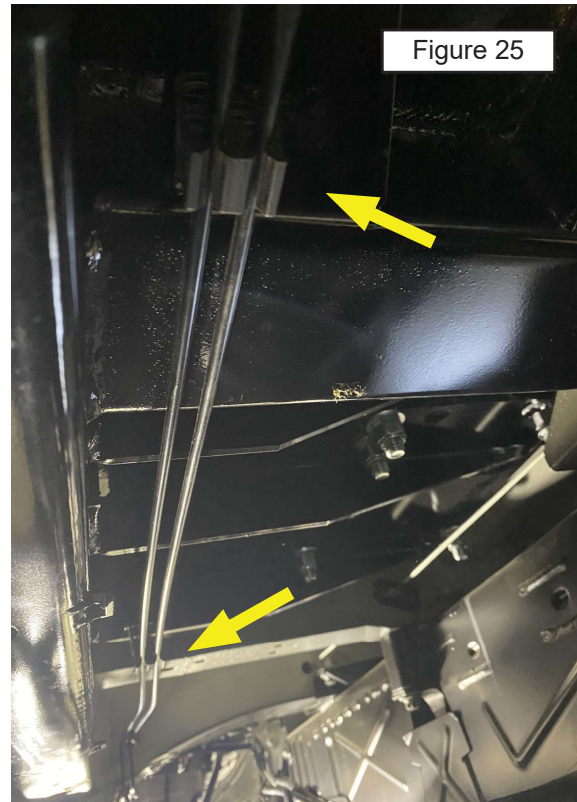
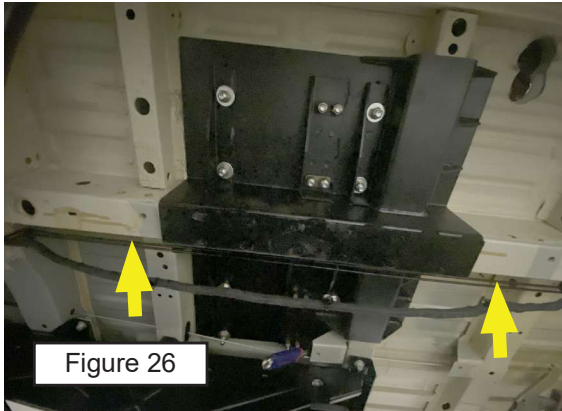

c. Having the brake lines removed from the (4) clips, will help prevent damage and add some flexibility in the lines to maneuver the seat bracket out and the new one back in place during the install.

d. Position the coolant lines for the Rixen furnace out of the way then use a 3/4" socket and wrench on the bottom side to remove the (15) under body seat bracket bolts. (See Figure 27) **Note: this step will require (2) people (1) Inside the van to loosen the bolts and (1) on the bottom side to hold the nuts in place with a breaker bar and socket.**

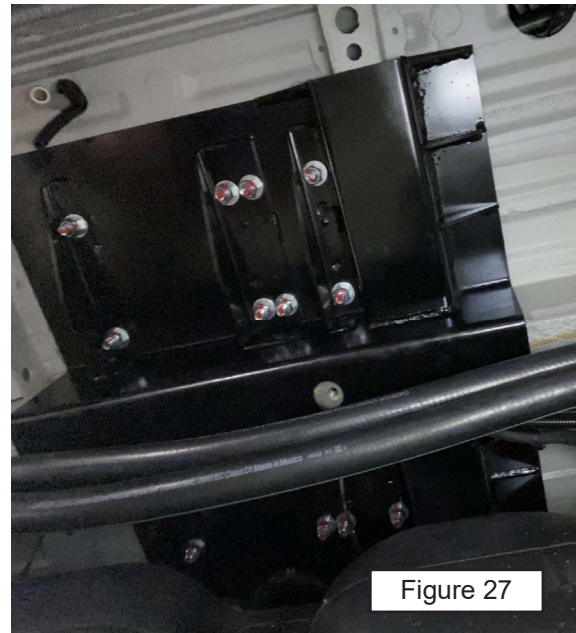

e. Carefully lower the under-body bracket down making sure not to damage any fuel or break lines in the area. (See Figure 28)

f. Once the under-body bracket is down on the ground, use a flat head screwdriver to press the center pin on the break line clips and remove the (2) clips from the bracket. (See Figure 29) Verify that the aluminum spacers have remained in place on both the top and bottom side of the van. (4) long spacers (4) short spacers as shown. (See Figure 30)

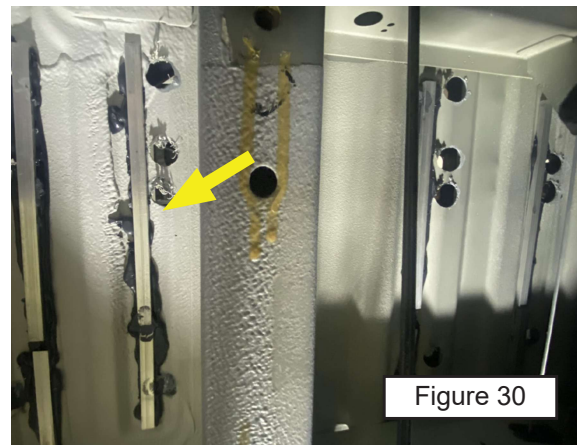
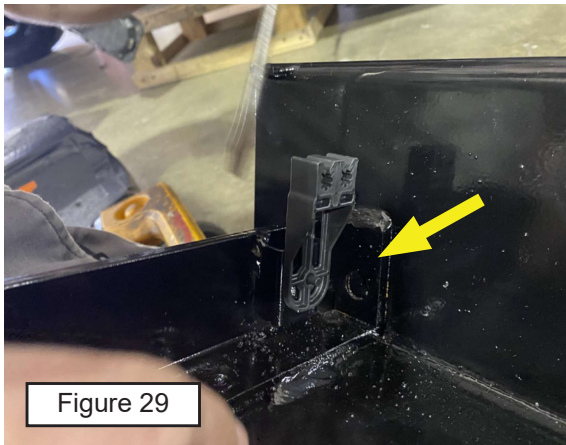

9. Replace Upper and Lower Seat Mounting Brackets

a. Remove upper seat mounting brackets from inside the van, then position the new upper seat mounting bracket back in the original place. (See Figure 31)

b. apply glue to the backside of each (1) luan shim then position the shim to the front of the floor bracket, and slide under the sub-floor. **Note: apply seal bond 105 to the bottom of the luan then slide the luan under the flooring to provide additional support under the sub-floor.**

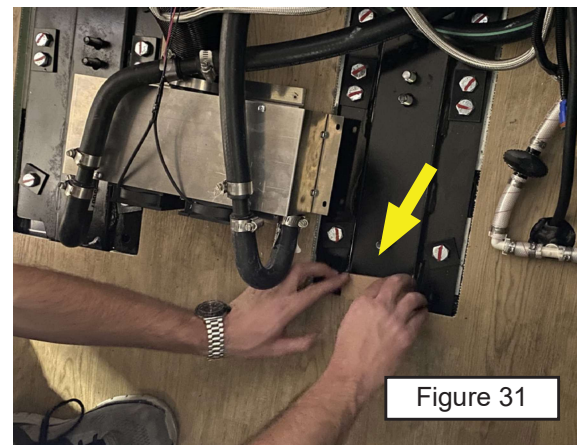

c. Carefully position the lower seat mounting bracket up and over all the coolant lines, fuel lines and brake lines making sure not to damage any of these lines while aligning the new bracket in place over the frame rail. (See Figure 32)

d. With the top and bottom set of brackets positioned in place, feed the bolts back through the bracket from the top side and reuse the single and double hole washer plates in the corresponding locations. Thread on washers and new nylon lock nuts on the bottom side van. (See Figure 33) **Note: the floor brackets will need to be aligned with seat base, before the bolts are tightened and torqued.**

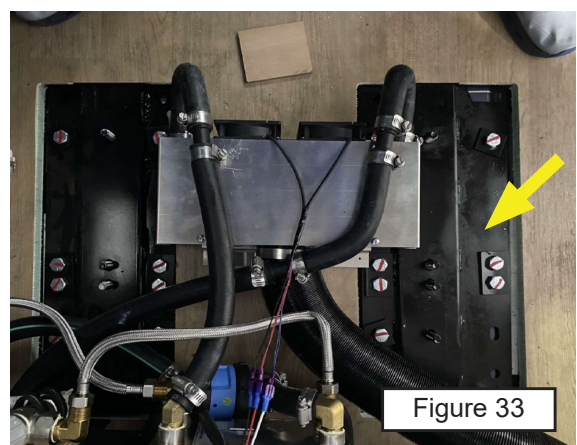
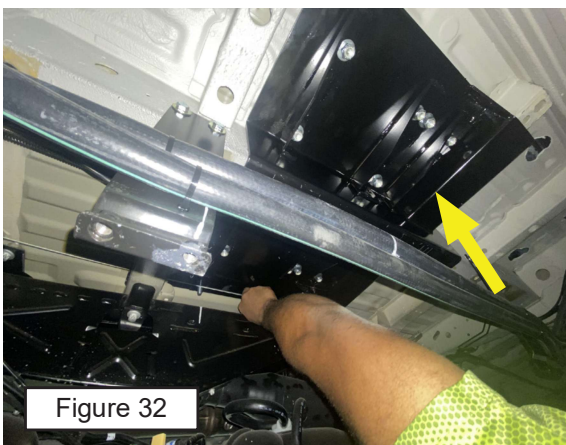

e. Align the studs on the top set of brackets, spaced at 17 3/8" to center of stud, then verify that the seat base matches that same measurement. With the brackets in the correct location then tighten and torque each bolt down. (See Figure 34)

f. Once aligned, use a torque wrench and a 3/4" socket to torque each of the (15) bolts to **102 NM or 75 ft lbs.** **Note: this step will require (2) people (1) Inside the van to torque the bolts and (1) on the bottom side to hold the nut in place.**

g. Once all bolts are secured and properly torqued, use a red paint pen on both the top and bottom side of the van to mark that each of the bolts have been torqued to the appropriate specs. (See Figure 35)

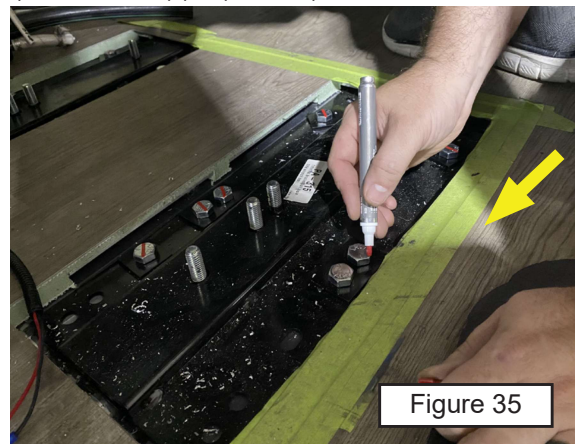
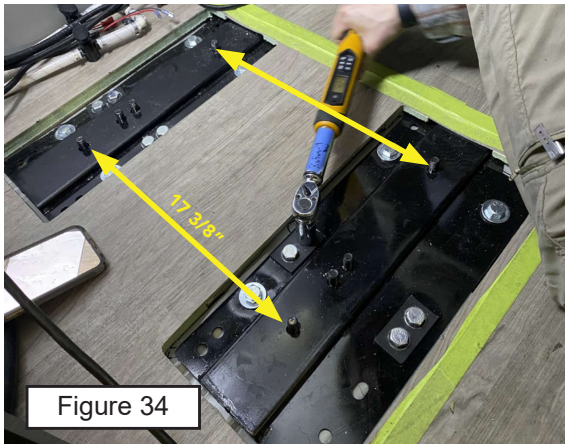

10. Re-Install Fuel Tank

a. Start with re-installing the brake line clips back onto the lower seat bracket on the underside of the van, by positioning the clip into the mounting locations prior depressing the center pin to lock the clip in place. Once in place reposition the brake lines back into all (4) clips making sure not to twist them. (See Figure 36)

b. Next re-install (2) zip ties back through the bracket to secure the harness along the frame rail, (See Figure 37) then install (2) more zip ties back around the coolant lines to secure them through the holes on

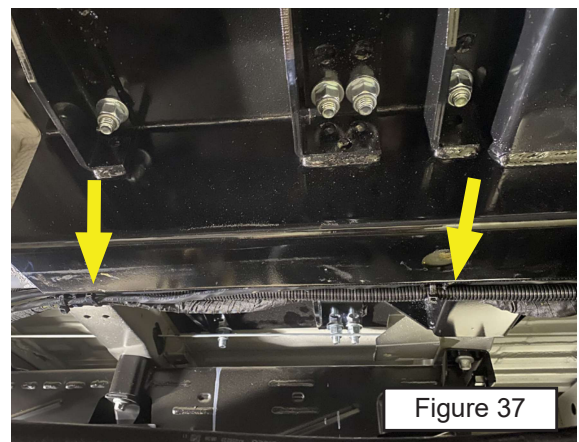
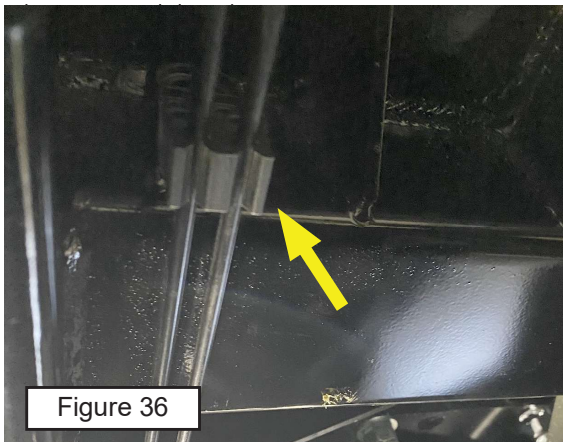

c. Carefully reposition the fuel tank back in place and return the fuel neck back up and through the exterior of the van near the driver's side door. Make sure when lifting the tank back in place to reinstall the breather line back through the opening in the frame rail. (See Figure 38)

d. Next re-secure the (3) tank straps in place around the fuel tank, use the E16 external torx socket to torque all (6) factory bolts back to **56 NM or 41.3 ft-lbs**, then use a paint pen to mark that each bolt has been torqued. (See Figure 39)

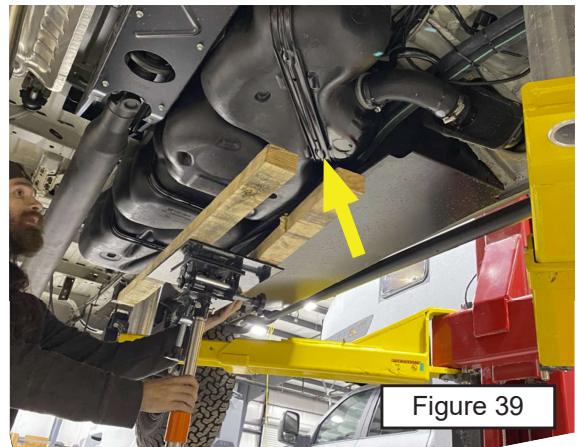
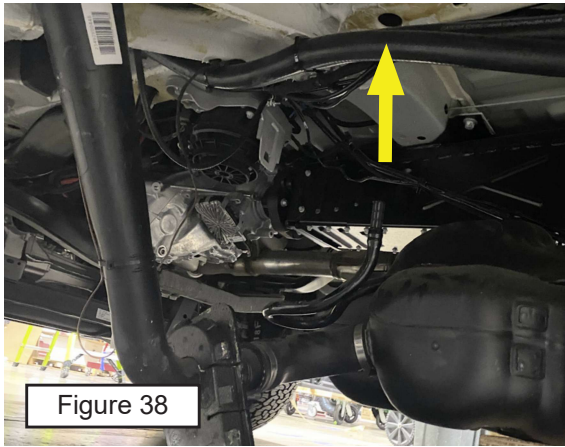

e. Reinstall the lower foam grommet around the fuel filler neck and back in place on the bottom side of the chassis. (See Figure 40)

f. Use a T-30 Torx bit to reinstall the fuel filler neck using the same factory hardware, then install the (4) bolts securing the fuel filler neck housing. Reposition the fuel filler door then secure the (2) bolts holding the fuel door hinge to the van. (See Figure 41) **Note: Verify that the fuel door aligns correctly with the van body and adjust accordingly with the 2 bolts on the hinge.**

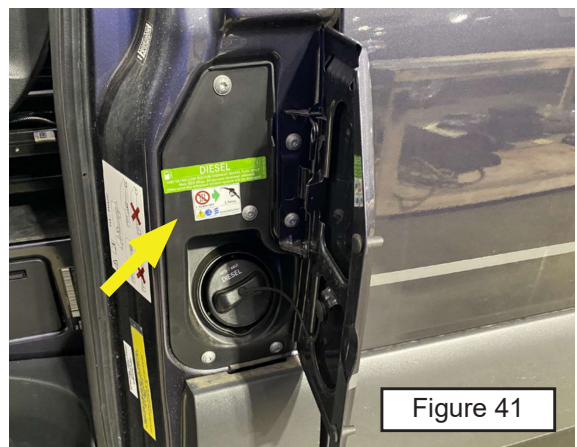
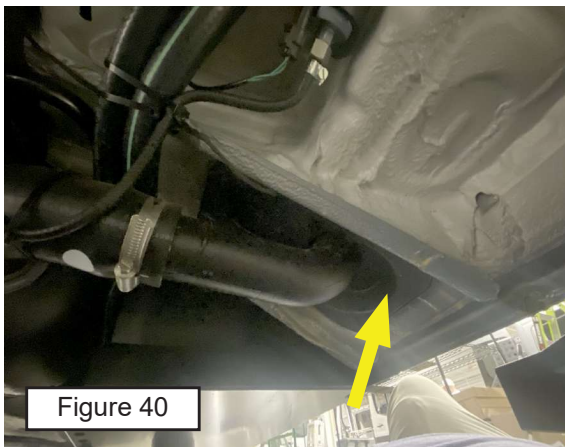

11. Re-Install Grey Tank and Grey Tank Bracket

a. Position the grey tank and pan on the jack and back in line with the support brackets. **Note: when raising the grey tank back in place, use a jack to help lift and hold the grey tank assembly while the plumbing connections are made.**

b. Apply quadmax to the 90° elbow macerator fitting at the end of the grey tank and re-apply pipe joint compound to the hepvo valve that is running along the top of the grey tank. (See Figure 42)

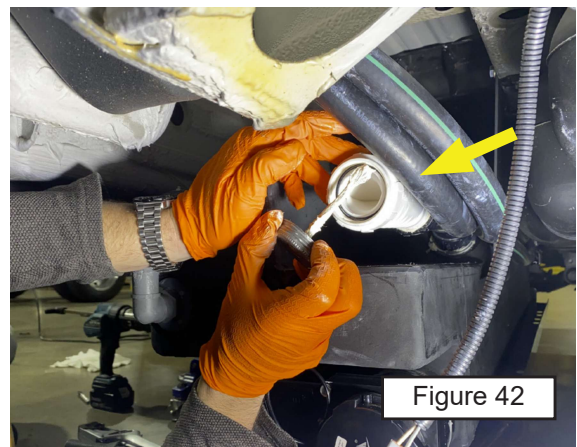

c. Once the joint compound has been applied to the hepvo valve and the Quadmax is applied to the elbow fitting, carefully lift the tank in place. While lifting the tank feed the grey tank vent pipe back through the floor hole.

d. With the tank remaining in the up position, secure the hepvo valve once aligned (See Figure 43) and connect the grey macerator line to the 90° elbow at the end of the grey tank. Wipe away any excess quadmax sealant from the fitting and re-secure the hose clamp. (See Figure 44)

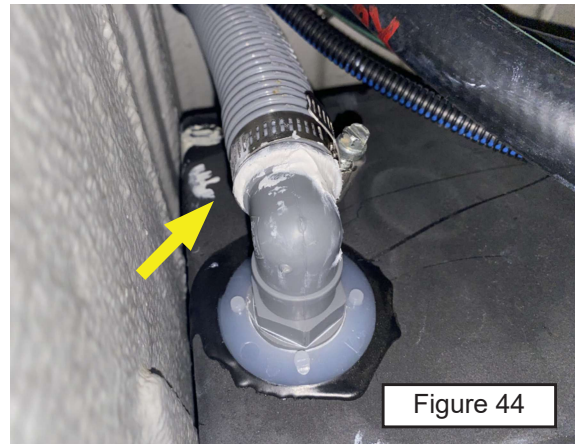
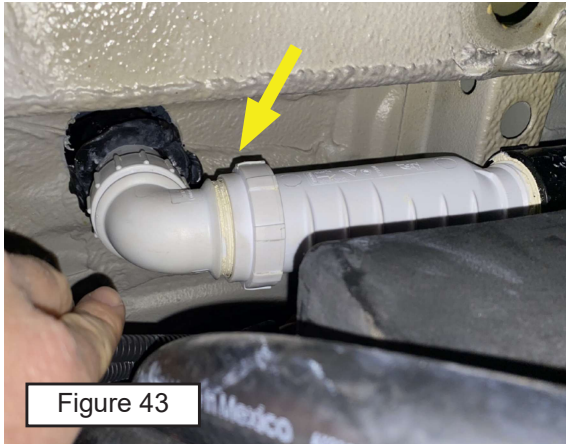

e. Secure the grey tank monitor deutsch connector back to the harness along the topside of the grey tank. (See Figure 45) **Note: the harness zip ties may need to be removed in order to reinstall the connection, if zip ties are removed make sure to replace them with new zip ties in the same area to prevent the harness from hanging below the chassis of the van.**

f. With the hepvo valve reconnected, realign the holes of the grey tank pan with the brackets and reinstall the (8) 3/8" x 1/2" SS black hex head bolts, and (8) 3/8" SS flat washers through the bottom side of the bracket and secure using a 9/16" socket and combination wrench. (See Figure 46)

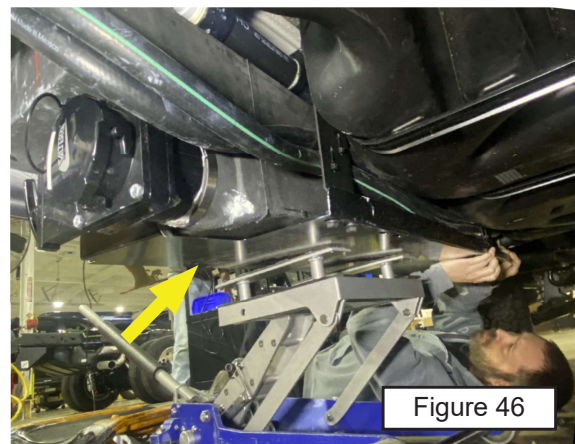
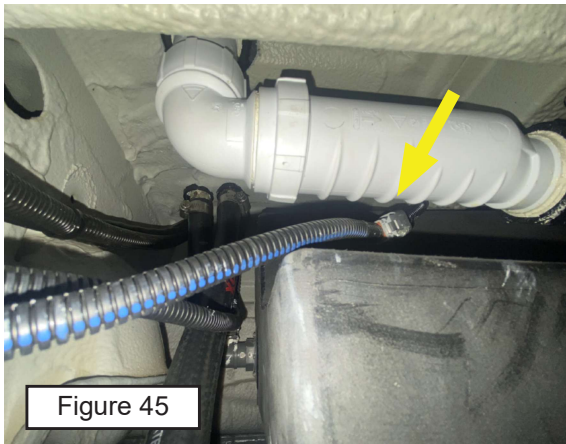

12. Install Coupling on Grey Tank Vent

a. Inside the van on the front of the shower wall use a hose cutter to trim off approximately 2", making sure both the top and bottom cut are straight and there is no angle at the end of the line.

- b. Apply the all purpose plumbers cement to both sides of the grey tank vent hose then install the (2) 1 1/4" x 1 1/2" PVC bushing adapter to each side of the grey tank vent hose. (See Figure 47)
- c. With the (2) PVC bushing in place at the (2) open ends of the grey tank vent lines, next apply the all purpose plumbers cement to the 1 1/2" x 1 1/2" Hub x Hub black ABS coupling, then position the coupling between the (2) bushing adapters. (See Figure 48)
- d. Wipe up any excess plumber's cement, then let the glue set prior to testing.

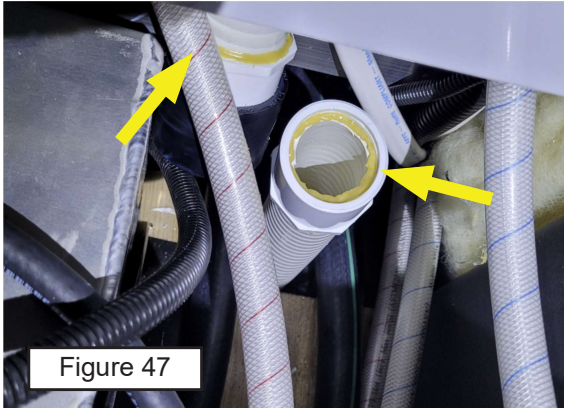

Figure 47

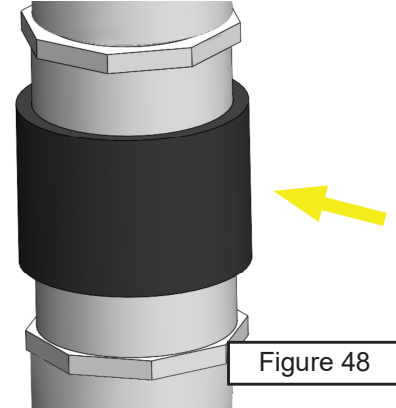

Figure 48

13. Perform a Plumbing Inspection and Flood Test

- a. To perform a flood test first turn the MODE Com system on and verify that there are no sink drain stoppers in the sink. **Note: system must be on to monitor the grey tank levels.**
- b. Using a hose carefully fill the sink up with water to the ridge, where the sink lid rests.
- c. With the sink full of water, inspect galley area for any leaks in the sink or drain.
- d. Next press and hold the sink drain pump button, on the galley to empty the water from the sink. While holding the button, have a second person verify that there are no leaks around the macerator line on the grey tank fitting. Note: do not press the sink drain pump button without water in the sink.
- e. Next place the hose in the shower of the van and fill the grey tank with water, while filling the shower with water monitor the grey tank level on the MODE Com screen.
- f. Once the grey tank level on the screen reads 100%, continue to slowly fill the tank until there is approximately 1" of water standing in the shower pan, then turn the hose off.
- g. With the grey tank full let the water sit for approximately 10 minutes and inspect all of the plumbing around the grey tank, shower drain as well as the coupling on the grey tank vent line.
- h. Repair all leaks and repeat testing until no leaks occur. If there are no leaks detected, while the testing is performed, drain the grey tank by removing the cap at the back of the grey tank.
- i. Once the testing is completed, wipe down any water left inside the galley and shower area.

14. Re-install Seat and Seat Shroud

a. Inside the van carefully lift and re-position the seat back in place on the studs, making sure not to damage the studs, wiring or Rixen plumbing as you set the seat down on the studs. (See Figure 49)

b. Once aligned, install the original (8) 1/2" SAE washers and (8) new 1/2"-13 nylon lock nuts to secure the seat base to the floor brackets. Use a torque wrench and a 3/4" socket to torque each of the (8) nuts to **102 NM or 75 ft lbs.** **Note: new 1/2"-13 nylon lock nuts need to be installed once the seat is reinstalled.**

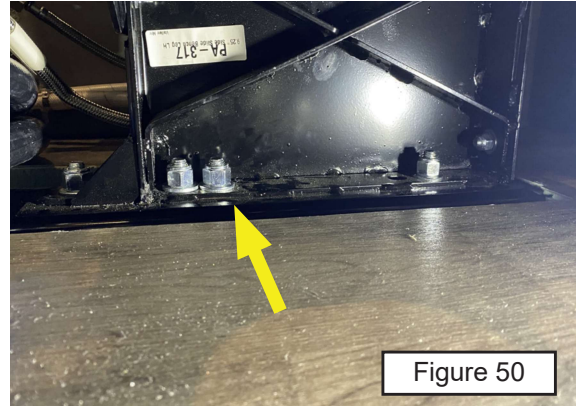

c. Use a paint pen on both the top and bottom side of the van to mark that each of the bolts have been torqued to the appropriate specs. (See Figure 51) Next reposition the air handler back in place and install the wafer head screws along the front and back edge of the air handler. (See Figure 52)

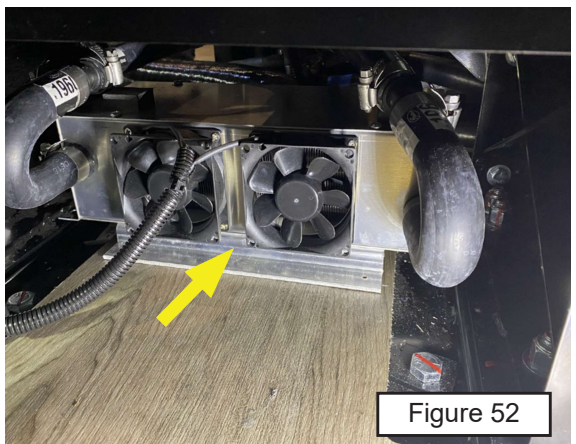
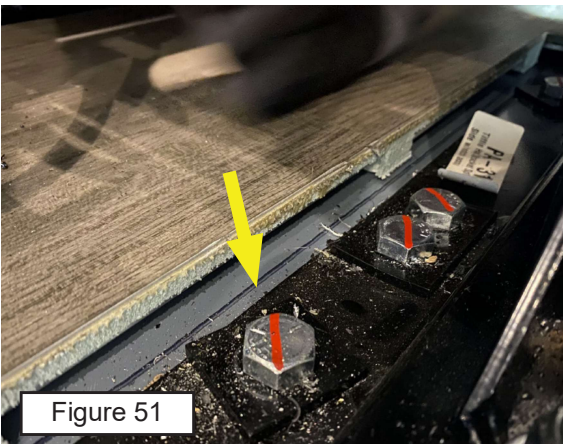

d. Position the seat shroud back in place and install the (2) wafer head screws from the front and (1) wafer head screw from the side of the lower seat shroud panels. (See Figure 53 & Figure 54)

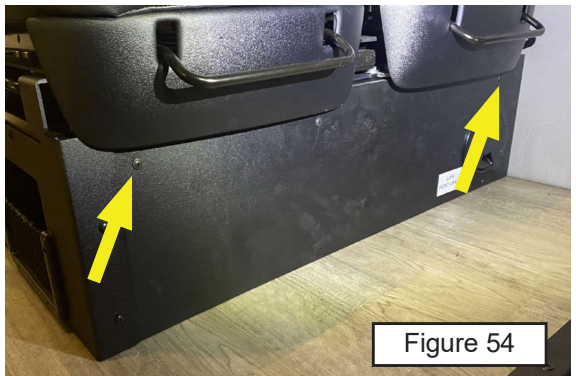
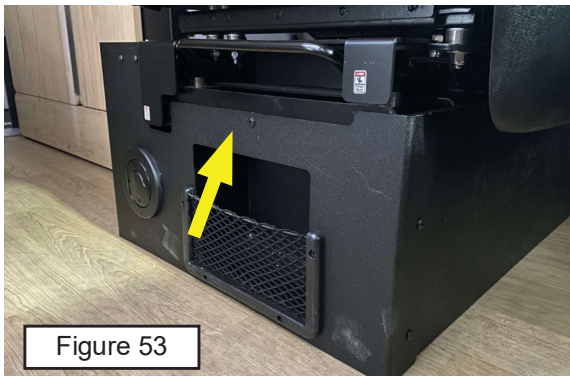

e. Position the air duct back on the side outlet of the seat shroud and use a 5/16" socket to secure the hose clamp inside of the seat shroud. (See Figure 55)

f. Pass the (2) loomed cables back through the top plate of the seat shroud, then connect back to the (2) seat harness pig tails. Test seat operation using switches on the driver side wall to ensure seats are connected to the proper connectors as labels on the wall switch.

g. Reposition the top plate back in place and install the (3) wafer head self-tapping screws back down through the panel, then re-install the (3) wafer head wood screws along the angled trim to the front face of the shower finish panel. (See Figure 56)

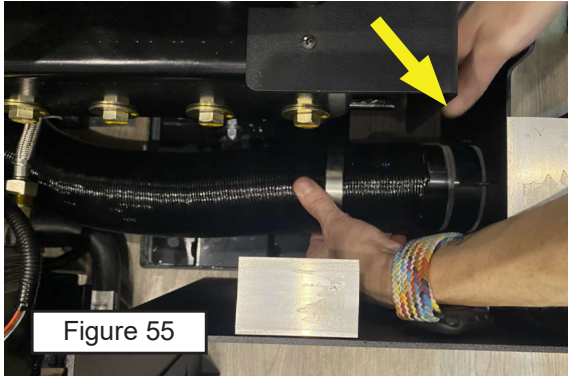

Figure 55

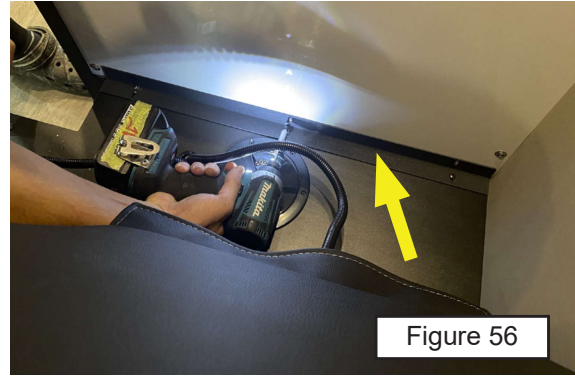

Figure 56

15. Re-install Fridge

a. Carefully position the fridge inside the van and connect (2) spade connections on the backside of the fridge. **Note: some models will also have 110 power cable that is taped to the backside of fridge this will need to be connected to an Internal 110 receptacle prior to installing the fridge.** (See Figure 57)

b. Once fridge is aligned, open the fridge door and take the phillips bit and 1/8" allen key to re-install the (4) screws to secure the fridge to the galley. (See Figure 58) (#10-24 x 1" SS barrel nut, 1/4" PVC washer, #10-24 x 1.25" Flat Head Screw and aluminum counter sunk washer) **Note: tighten hardware using a philips head screwdriver from the inside of the fridge, while holding the allen wrench from the outside. Make sure not to overtighten hardware to prevent damaging the fridge or galley.**

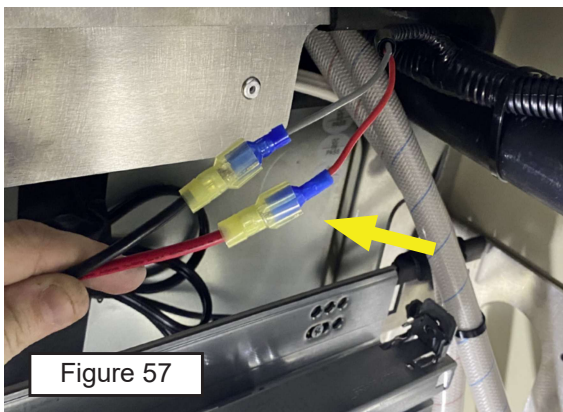

Figure 57

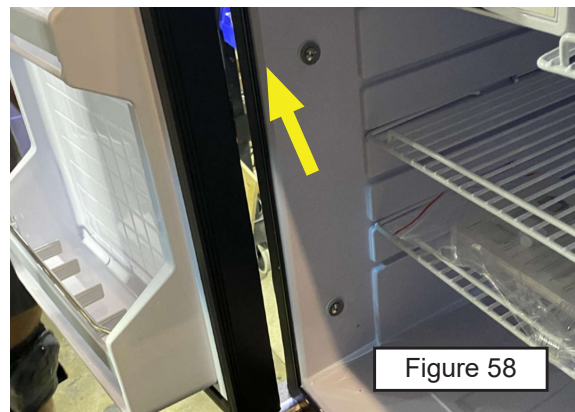

Figure 58

c. Zip tie the spade connection for the fridge out of the way, then reinstall the drawers back into the galley. Once drawers are installed, inspect all work and ensure no additional damage was caused during the install, verify that the fridge and heat are operating as intended and this completes the process.



NHTSA Recall # 25V-070 Checklist

Rev03062025

Instructions: Complete this checklist along with the procedure outlined in the document "03062025 NHTSA Recall #25V070 MODE XO Seat." Once the recall repair is complete, supply completed form to Storyteller Overland via email at service@storytelleroverland.com

Service Center Name: _____ **Date:** _____

Name/Employee # of person(s) performing recall service: _____

Van Owner's Name: _____ **Van's VIN:** _____

Step 1: Inspect Unit for any damage prior to work: _____

Step 5: Aisle side seat's left rear track mounting bracket replaced with (2) provided washer plates. Initials: _____

Step 8f: All aluminum spacers are in place on top and bottom of van floor. Initials: _____

Step 9b: Luan shims glued back into place on both upper seat mounting brackets. Initials: _____

Step 9f: All (15) seat mounting bracket bolts torqued to **102 Nm (75 ft-lbs)**. Initials: _____

Step 10a: Brake lines clipped back into place at all points. Initials: _____

Step 10b: Harness and coolant lines resecured as specified with zip ties. Initials: _____

Step 10d: All (6) fuel tank strap bolts torqued to **56 Nm (41.3 ft-lbs)**. Initials: _____

Step 10e: Fuel filler foam repositioned into place. Initials: _____

Step 10f: Fuel fill door aligned square to van body. Initials: _____

Step 11b: Quad Max applied to macerator elbow. Pipe Joint Compound applied to Hepvo valve. Initials: _____

Step 12: Gray tank vent line couplings glued together. Initials: _____

Step 13: Were any leaks found during leak testing? (circle one) YES NO If yes, where? _____

Repair any leaks (If applicable) until no leaks are found. Initials: _____

Step 14b: Torque seat mounting nuts to **102 Nm (75 Ft-lbs)**. Initials: _____

Step 14f: Seats hooked up to proper connectors to function per labeled wall switches. Initials: _____

Step 15c: No additional damage was done to the unit. Initials: _____