



Service Engineering Operations  
Customer Service Division

Ford Motor Company  
PO Box 1904  
Dearborn, Michigan 48121

March 2, 2026

**TO:** All U.S. Ford and Lincoln Dealers  
**SUBJECT:** **NEW VEHICLE DEMONSTRATION / DELIVERY HOLD -  
Safety Recall 25S01 – Supplement #1**  
Certain 2021-2024 Model Year Bronco Vehicles  
Rear Shock Absorber External Reservoir Corrosion  
**REF :** **NEW VEHICLE DEMONSTRATION / DELIVERY HOLD -  
Safety Recall 25S01**  
Dated: August 7, 2025

**New! REASON FOR SUPPLEMENT**

- **Affected Vehicles:** U.S. population updated.
- **FSA Program Options:** Added new section.
- **Reference Material:** Added new section.
- **Additional Repair (Labor Time and/or Parts):** Add direction to review FSA Policy Documents.
- **Labor Allowances and Parts Ordering Information:** Updated labor allowances charts, parts ordering information and parts lists, and included direction to review FSA Policy Documents.
- **Technical Instructions:** Included note and example of differences in rear upper shock absorber mount stud thread pitch to facilitate proper part ordering.

**AFFECTED VEHICLES (U.S. Population Of Affected Vehicles 149,072):**

Vehicle	Model Year	Assembly Plant	Build Date Range
Bronco	2021-2024	Michigan	September 23, 2020 through July 23, 2024

Affected vehicles are identified in OASIS and FSA VIN Lists.

**REASON FOR THIS SAFETY RECALL**

In some of the affected vehicles, the rear shock absorbers may experience corrosion between the external reservoir mounting flange and the damper body. This may result in degradation of the external reservoir welds causing fluid leaks near the rear wheels, noise, separation of the external reservoir and/or a bouncy ride.

Rear shock absorber external reservoir(s) that separate from the vehicle can create a potential road hazard for other road users, increasing the risk of a crash.

**SERVICE ACTION**

Before demonstrating or delivering any new in-stock vehicles involved in this recall, dealers are to inspect both rear shock absorbers for leaking or missing external reservoirs. If either rear external reservoir is leaking or missing, both rear shock absorbers are to be replaced. If the external reservoirs are intact and no leaks are found, the external reservoir to shock absorber joint is to be sealed and a revised external reservoir retention clamp/shield is to be installed. This service must be performed on all affected vehicles at no charge to the vehicle owner. For new vehicle storage guidelines, refer to EFC13033, Storage Guidelines for New Vehicles.

### **SERVICE ACTION (continued)**

To assist vehicle owners to have this repair completed, dealers should:

- Arrange to pick up the owner's vehicle and drive it to the dealership for repairs.
  - Re-deliver the owner's vehicle after repairs have been completed.
- Pick-Up & Delivery should be made available for all customers. Refer to the Rental and Claiming sections for further details.

### **New! FSA PROGRAM OPTIONS**

<b><i>Program Option</i></b>	<b><i>Eligibility</i></b>	<b><i>Comments</i></b>
<i>Mobile Repair</i>	<i>No</i>	<i>See <b>Mobile Service Repair Assessment Level</b> section below, if applicable.</i>
<i>Over-the-Air (OTA) Update</i>	<i>No</i>	<i>See <b>Over-The-Air (OTA) Updates</b> section of the FSA Policy Document, if applicable.</i>
<i>Rentals</i>	<i>No</i>	<i>See the <b>Rental Vehicles</b> section below, if applicable.</i>
<i>Alternative Transportation Available</i>	<i>No</i>	<i>See <b>Alternate Transportation</b> section in the FSA Policy Document.</i>
<i>Pickup &amp; Delivery (PDL)</i>	<i>Yes</i>	<i>See <b>Pickup &amp; Delivery</b> section in the FSA Policy document.</i>
<i>Towing</i>	<i>No</i>	<i>See <b>Towing</b> section below, if applicable.</i>
<i>Essential Special Service Tools (ESST)</i>	<i>No</i>	<i>See <b>Technical Instructions and/or Workshop Manual (WSM)</b> as needed.</i>
<i>Administrative Allowance</i>	<i>No</i>	<i>See <b>Administrative Allowance</b> section in FSA Policy Document, and if applicable, <b>Labor Allowances</b> table below.</i>
<i>Owner Refunds</i>	<i>Yes</i>	<i>See <b>Owner Refunds</b> section below, if applicable.</i>
<i>Photo Submission</i>	<i>Yes</i>	<i>See <b>Repair Photo Submission</b> section below, if applicable.</i>

**Note:** For further information on certain Program Options above, see the corresponding section within the FSA Policy Document.

### **OWNER NOTIFICATION MAILING SCHEDULE**

Owner letters were mailed the week of August 11, 2025. Dealers should repair any affected vehicles that arrive at their dealerships, whether or not the customer has received a letter.

### **PLEASE NOTE**

**Federal law requires dealers to complete this recall service before a new vehicle is delivered to the buyer or lessee. Violation of this requirement by a dealer could result in a civil penalty of up to \$27,168 per vehicle. Correct all vehicles in your new vehicle inventory before delivery.**

## **ATTACHMENTS**

- Technical Instructions
- Owner Notification Letter
- Vehicle Pickup & Delivery Record
- Recall Reimbursement Plan

## **New! REFERENCE MATERIAL**

- *Warranty & Policy Manual (located on FMCDealer Warranty Portal Page):*  
[www.fmcdealer.dealerconnection.com/content/fmcdealer/us/en/parts\\_service/wty.html](http://www.fmcdealer.dealerconnection.com/content/fmcdealer/us/en/parts_service/wty.html)
- *FSA Policy Document (located on FMCDealer FSA Resources Page for Ford and Lincoln dealerships):*  
[www.fmcdealer.dealerconnection.com/content/fmcdealer/us/en/parts\\_service/fsa/rsc.html](http://www.fmcdealer.dealerconnection.com/content/fmcdealer/us/en/parts_service/fsa/rsc.html)
- *FSA Policy Document (located on the Fleet SharePoint site for Fleets with in-house warranty):*  
<https://azureford.sharepoint.com/sites/OneWarrantySolution/usfleet/SitePages/Home.aspx>

## **QUESTIONS & ASSISTANCE**

For questions and assistance, contact the Special Service Support Center (SSSC) via the SSSC Web Contact Site. The SSSC Web Contact Site can be accessed through the Professional Technician System (PTS) website using the SSSC link listed at the bottom of the OASIS VIN report screen or listed under the SSSC tab.

Customer Service Division

**Safety Recall 25S01 – Supplement #1****MOBILE SERVICE REPAIR ASSESSMENT LEVEL**

- All Vehicles Affected
  -  - Not a Mobile Service Repair (MRA5)

**OASIS ACTIVATION**

OASIS was activated on August 7, 2025.

**FSA VIN LISTS ACTIVATION**

FSA VIN Lists were made available through <https://web.fsavinlists.dealerconnection.com> on August 7, 2025. Owner names and addresses were made available on August 29, 2025.

**NOTE:** Your FSA VIN Lists may contain owner names and addresses obtained from motor vehicle registration records. The use of such motor vehicle registration data for any purpose other than in connection with this recall is a violation of law in several states, provinces, and countries. Accordingly, you must limit the use of this listing to the follow-up necessary to complete this recall.

**SOLD VEHICLES**

- Ford has not issued instructions to stop selling/delivering or driving used vehicles under this safety recall. Owners should contact their dealers for an appointment to have their vehicles remedied as soon as practicable.
- Immediately contact any of your affected customers whose vehicles are not on your VIN list but are identified in OASIS. Give the customer a copy of the Owner Notification Letter (when available) and schedule a service date.
- Correct other affected vehicles identified in OASIS which are brought to your dealership.
- Dealers are to prioritize repairs of customer vehicles over repairs of new and used vehicle inventory.

**STOCK VEHICLES**

- Correct all affected units in your new vehicle inventory before delivery.
- Use OASIS to identify any affected vehicles in your used vehicle inventory.

**DEALER-OPERATED RENTAL VEHICLES**

The Fixing America's Surface Transportation (FAST) Act law effective June 2016 prohibits a rental company from selling, renting, or leasing vehicles subject to a safety or compliance recall. Please consult your legal counsel for legal advice.

**BRANDED / SALVAGED TITLE VEHICLES**

Affected branded / salvaged title vehicles are eligible for this recall.

**OWNER REFUNDS**

- **This Safety Recall must still be performed, even if the owner has paid for a previous repair. Claiming a refund will not close the recall on the vehicle.**
- Ford Motor Company is offering a refund for owner-paid repairs covered by this recall if the repair was performed before the date indicated in the reimbursement plan, which is posted with this bulletin. Owners are directed to seek reimbursement through authorized dealers or, at their option, directly through Ford Motor Company at PO Box 6251, Dearborn, MI 48121-6251.

**Safety Recall 25S01 – Supplement #1****OWNER REFUNDS (continued)**

- Dealers are also pre-approved to refund owner-paid emergency repairs that were performed away from an authorized servicing dealer after the end date specified in the reimbursement plan. Non-covered repairs, or those judged by Ford to be excessive, will not be reimbursed.
- Refunds will only be provided for the cost associated with replacement of rear shock absorbers due to missing or leaking external reservoirs.

**RENTAL VEHICLES**

Rental vehicles are not approved for this program.

**REPAIR PHOTO SUBMISSION**

Ford has requested photo evidence prior to performing the repair for this FSA.

- The SSSC must provide approval prior to performing the repair.
- Use APPROVAL REQUEST contact type ONLY.
- Contact the SSSC and upload the necessary photo or copy of documentation as an attachment for review. **Photos of the VIN, RO and of the leaking or missing rear shock absorber reservoir(s) are to be submitted for review.** This can be done in two ways:
  - Directly in the SSSC contact request form while submitting your contact on your desktop.
  - Via PTS Mobile under the Images / Files Upload menu selection
    - You should select SSSC in the sub-menu and ensure your P&A code is correct. Upload the photo(s) by selecting the appropriate FSA with the option to use a prior contact ID. These photo(s) will be associated with your SSSC contact during submission.
    - If you have not submitted a SSSC contact yet, then you can still upload the photo(s) via PTS Mobile, and the photo(s) will be available when opening your SSSC contact for this VIN and recall.
- Upon approval, the SSSC will provide an approval code that must be used for claiming.

**New! ADDITIONAL REPAIR (LABOR TIME AND/OR PARTS)**

Additional repairs identified as necessary to complete the FSA should be managed as follows:

- For related damage and access time requirements, refer to the Warranty and Policy Manual / Section 6 – Ford & Lincoln Program Policies / General Information & Special Circumstances for FSAs / Related Damage.
- **For vehicles within new vehicle bumper-to-bumper warranty coverage, no SSSC approval is required**, although related damage must be on a separate repair line with the “Related Damage” radio button checked.
  - Ford vehicles – 3 years or 36,000 miles
- **For vehicles outside new vehicle bumper-to-bumper warranty coverage:**
  - Submit an Approval Request to the SSSC Web Contact Site before completing the repair.
- *See “Additional Repair Info” in the FSA Policy Document for further Terms and Conditions.*



Safety Recall 25S01 – **Supplement #1**

**New!** LABOR ALLOWANCES

*Note: Only one labor operation may be claimed from this table. (Additional supplemental labor operations may be claimed from the Supplemental Labor Allowances table.)*

Description	Labor Operation	Labor Time Hour(s)
Inspect rear shock absorbers – short flange shock absorbers already installed – <b>PASS</b> <i>This labor operation code closes the FSA.</i>	25S01A	0.3
Inspect rear shock absorbers – <b>PASS</b> – Long flange shock absorbers with attached reservoir, no leaks, no excess corrosion – <b>Install retainer/shield kit.</b> <i>This labor operation code closes the FSA.</i>	25S01B	0.8
Inspect rear shock absorbers – <b>FAIL</b> – One or both rear shock reservoirs are leaking, corroded or missing – <b>replace both rear shock absorbers</b> <b>NOTE:</b> SSSC approval code is required to claim this operation. <i>This labor operation code closes the FSA.</i>	25S01C	1.8

**New!** SUPPLEMENTAL LABOR ALLOWANCES - These labor operation codes DO NOT close the FSA.

*Note: Claim any relevant supplemental labor operations in addition to the primary labor operation.*

Description	Labor Operation	Labor Time Hour(s)
<b>Ford Vehicle Pick-Up &amp; Delivery Allowance:</b> <b>This allowance is only for <u>non-eligible</u> 2025 Remote Experience Program Dealers.</b> <b>NOTE:</b> This allowance is for dealer-performed vehicle Pick-Up & Delivery for dealership repairs only. Can only be claimed once, regardless of outstanding FSAs repaired.	25S01PP	0.5
Time allowed to submit photos. If VOR is required and vehicle must be present in dealership to complete repair: <ol style="list-style-type: none"> <li>1. Attach a photo of door tag showing VIN.</li> <li>2. Attach a photo of vehicle RO.</li> <li>3. Attach a photo of the leaking or missing rear shock absorber reservoir(s).</li> <li>4. If the vehicle is off road, then refer to EFC14236. VOR escalation is required in DOW.</li> </ol>	25S01ZZ	0.2

Safety Recall 25S01 – **Supplement #1**

**New!** PARTS REQUIREMENTS / ORDERING INFORMATION

Inspection required, see Technical Instructions.

**Restricted Part Ordering:**

To place an order for rear shock absorbers and related hardware, submit a VIN-specific Part Order contact via the SSSC Web Contact Site.

If parts are on backorder, vehicle must be present in the dealership. The VIN-specific part order must provide the following:

1. Attach a photo of vehicle mileage.
2. Attach a photo of door tag showing VIN.
3. Attach a photo of the RO
4. Attach a photo of the leaking or missing rear shock absorber reservoir(s).
5. If the vehicle is off road, then refer to EFC14236. VOR escalation is required in DOW.

Service Part Number	Claim Quantity	Package Order Quantity	Number in Package	Description
MB3Z-18125-DA	As Needed		1	Rear Shock Absorber - SWB Badlands
MB3Z-18125-DB			1	Rear Shock Absorber - LWB Badlands
MB3Z-18125-DC			1	Rear Shock Absorber - SWB Sasquatch
NB3Z-18125-R			1	Rear Shock Absorber - LWB Sasquatch
<i>MB3Z-18125-CZ</i>			<i>1</i>	<i>Rear Shock Absorber - LWB Sasquatch 2021MY</i>
W720199-S440			4	Strut Rod Nut
W715135-S450			4	Upper Shock Mount Nut – <i>Fine Pitch M10 X 1.25MM</i>
<i>W520213-S440</i>			<i>2</i>	<i>Upper Shock Mount Nut – Coarse Pitch M10 X 1.5MM</i>
W719177-S439			4	Lower Shock Mount Bolt
W719178-S440			4	Lower Shock Mount Nut

Dealers will be notified via a DOES II communication if circumstances warrant a change in part supply strategy and when open ordering resumes.

**Order the parts below through normal order processing channels:**

Inspection required, see Technical Instructions.

**NOTE: These parts are NOT to be used on new shock absorbers.**

Service Part Number	Claim Quantity	Package Order Quantity	Number in Package	Description
NB3Z-18089-A	1	1	1	Rear Shock Absorber Sheild/Retainer Kit (Parts For 2 Shocks)
TA-357	1	1	6	Motorcraft® High Performance RTV Silicone

To guarantee the shortest delivery time, an emergency order for parts must be placed.

Safety Recall 25S01 – *Supplement #1*

**DEALER PRICE**

For the latest prices, refer to DOES II.

**New! PARTS RETENTION, RETURN, & SCRAPPING**

*Please refer to the FSA Policy Document for any and all questions on parts policy.*

**New! EXCESS STOCK RETURN**

*Please refer to the FSA Policy Document for any and all questions on parts policy.*

**New! REPLACED FSA PARTS INSPECTION AND SIGN OFF**

*Please refer to the FSA Policy Document for any and all questions on parts policy.*

## CERTAIN 2021-2024 MODEL YEAR BRONCO VEHICLES — REAR SHOCK ABSORBER EXTERNAL RESERVOIR CORROSION

### **NEW !** SERVICE PROCEDURE

**IMPORTANT!** The Service Technician Specialty Training (STST) Competency 10 certification requirement, in the U.S. market only, will be enforced starting with repair orders opened on or after August 31, 2024. Field Service Action (FSA) repairs will reject and the claim will not be paid if the repairing technician is not certified in STST Competency 10 FSA. See Electronic Field Communication (EFC) 15936 for more details.

1. With the vehicle in NEUTRAL, position it on a hoist. Follow the Workshop Manual (WSM) procedures in Section 100-02.
2. On both sides, inspect the rear shock to reservoir attachment flange. Slightly rotate the rubber stone shield to gain visual access to the flange. See Figure 1. Is the vehicle equipped with the long flanged reservoir? See Figure 2.

**Yes** - Continue to the next step.

**No** - This FSA does not apply. Lower the vehicle. This completes the FSA.

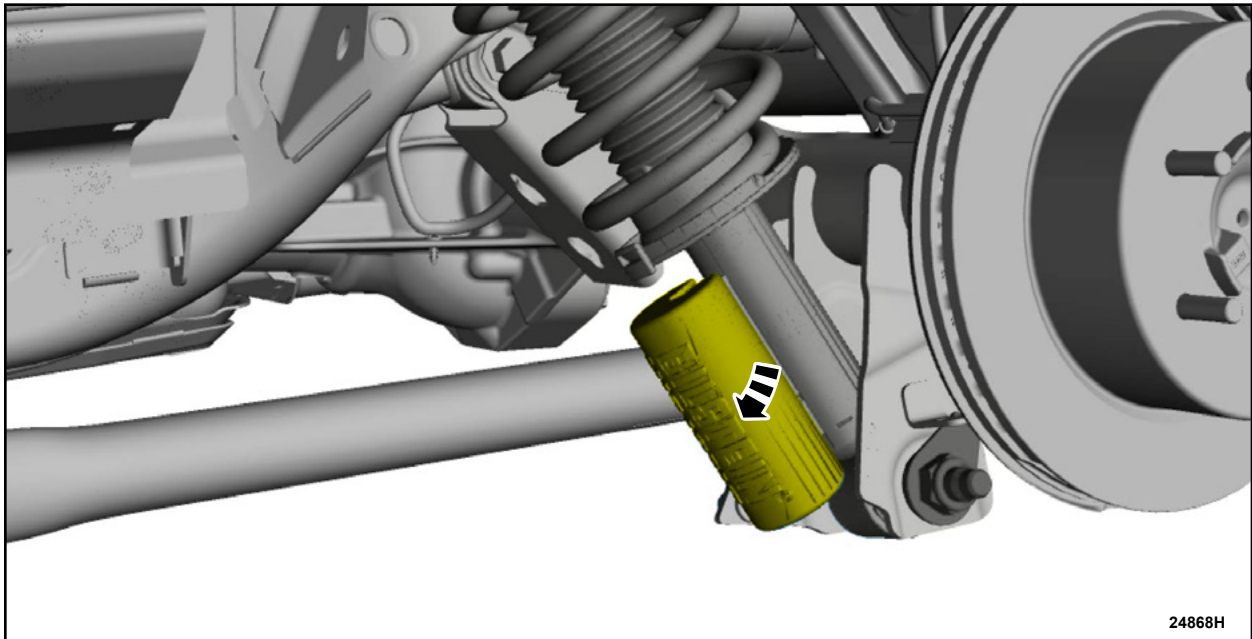

24868H

**FIGURE 1**



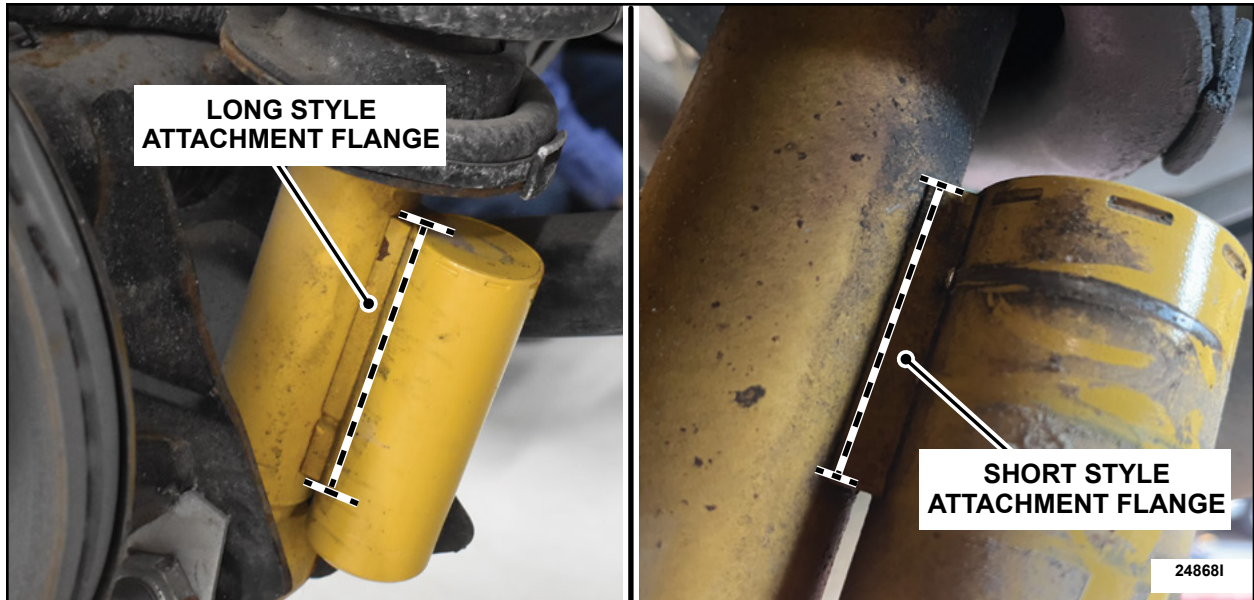

**FIGURE 2**

3. Remove both rear tires. Follow the WSM procedures in Section 204-04.
4. On both sides, remove and discard the rear shock absorber stone shields. See Figure 3.

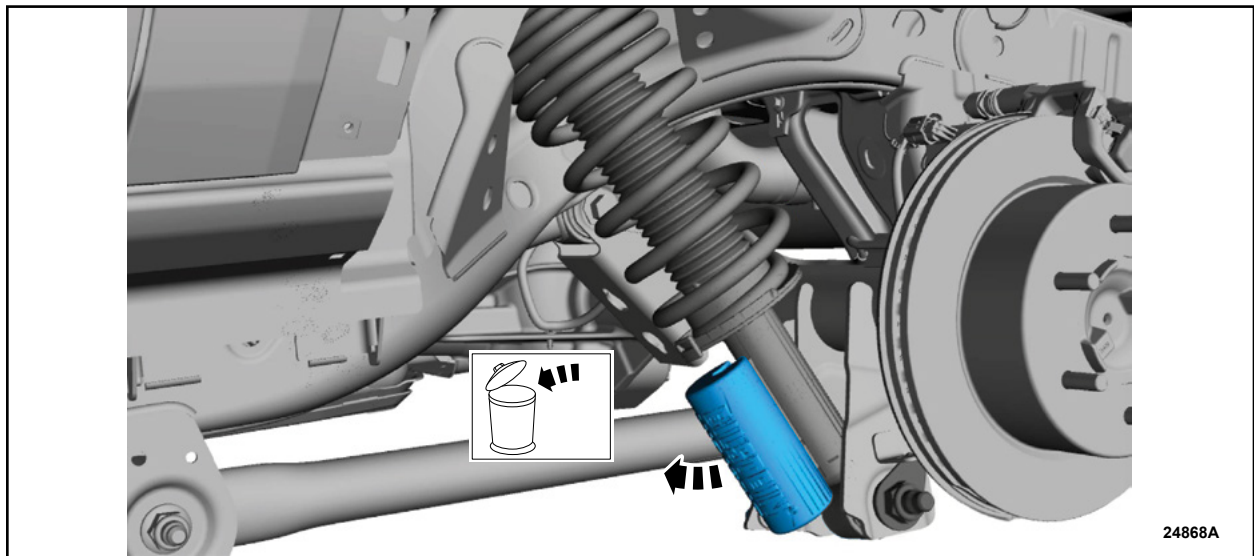

**FIGURE 3**



5. On both sides, inspect the rear shock and the shock to reservoir attachment flange areas for cracks, broken welds, leaks, and/or *missing shock reservoirs*. See Figures 4 and 5.

- Were any cracks, broken welds, leaks and/or *missing shock reservoirs* found on either shock?

**Yes** - Submit photos of the failed rear shock(s) to the Special Service Support Center (SSSC), refer to the Photo Request Submission on Pages 9 and 10. Wait for the SSSC approval to begin any repairs. **See the Notes below for parts ordering information.** Then, replace both rear shock absorbers. Follow the WSM procedures in Section 204-04. This completes the FSA.

**No** - Proceed to the next step.

**NOTE:** *Before ordering parts, inspect the upper shock mount thread size. There are two (2) different thread sizes for the upper shock mount, a M10x1.5mm and a M10x1.25mm. Make sure to order the correct thread size nuts for the upper shock mount, as they are not interchangeable. Refer to Figure 6.*

**NOTE:** *Hand start the upper shock mount nuts and only use hand tools to make sure the proper nuts are being installed on the upper shock mounts.*

**NOTE:** *Do Not install the shield and retainer kit on new shocks.*



FIGURE 4





FIGURE 5

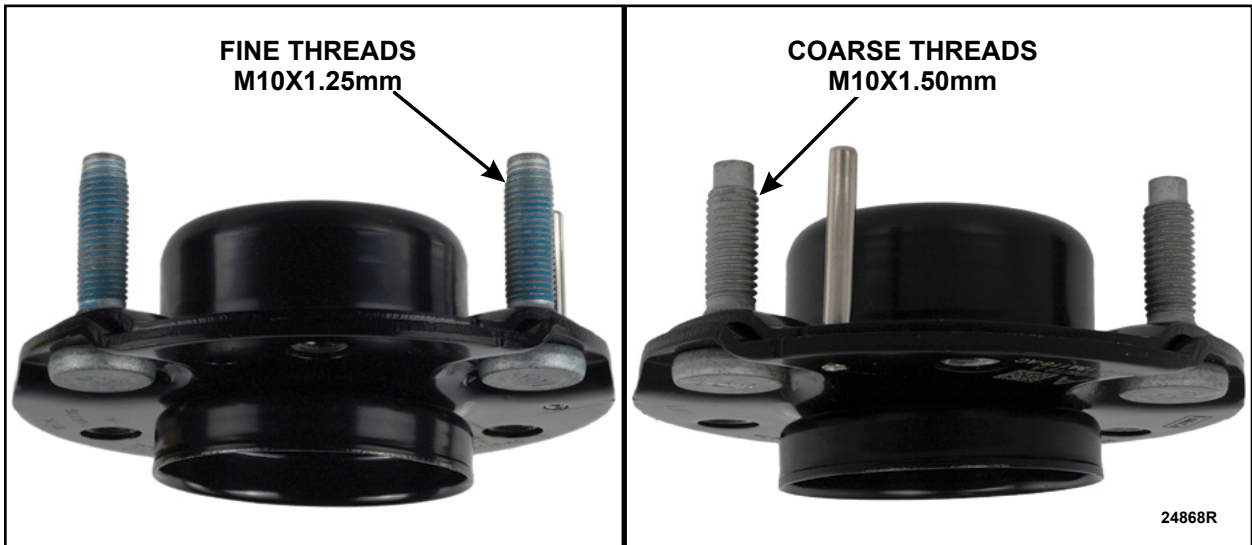

FIGURE 6



6. On both sides, use isopropyl or acetone to clean and fully dry the entire flange areas shown in Figure 7.

**NOTE:** All surfaces must be clean and dry. Use compressed air to remove dust, dirt, and loose particles from the surface. Degrease and wash off any contaminants that could impair adhesion.

**NOTE:** Suitable solvents include isopropyl alcohol or acetone. The surface should be free of wax, residual dirt, and debris once cleaned. An unclean surface will compromise the adhesion of the sealant to the shock. Do Not grind rust from the shock or flange areas.

**NOTE:** Rear shock removed for clarity.

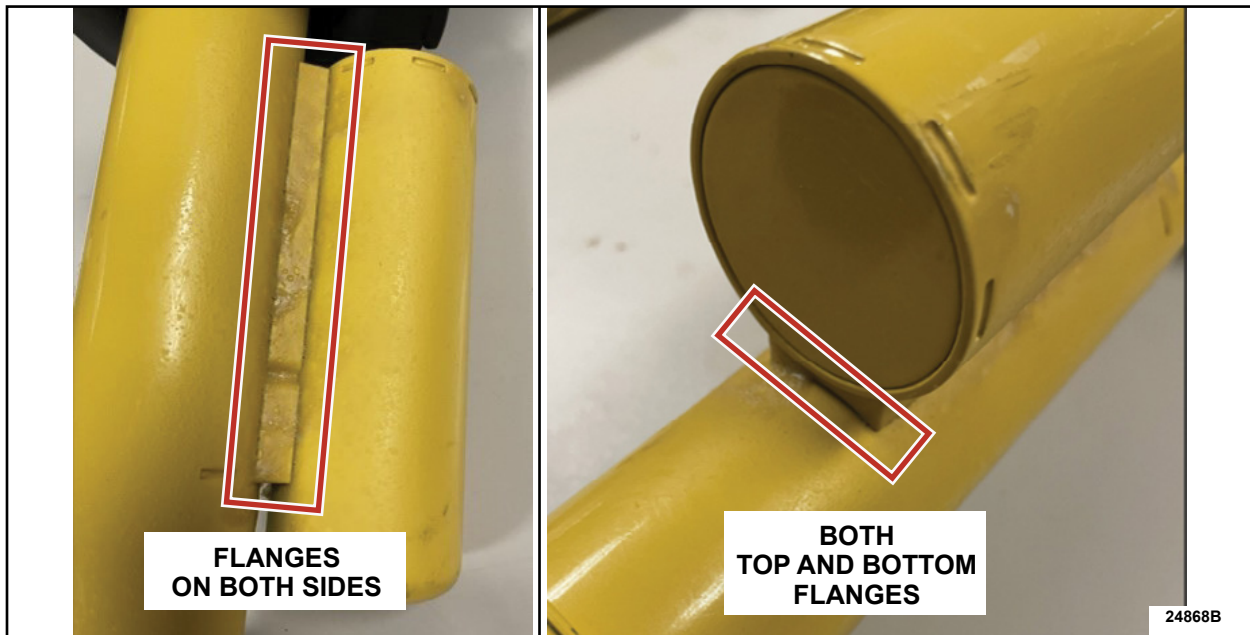

FIGURE 7



7. Using the provided Motorcraft® TA-357 High Performance Engine RTV Silicone, cut the sealant tube at a 45 degree angle for a quarter inch bead. Then, on both sides, apply a bead of sealant to the flange areas of the reservoir to shock body as shown in Figure 8. Continue applying the bead of sealant along both edges of the flange and until all flanges (top, bottom and both sides) around the reservoir are covered.

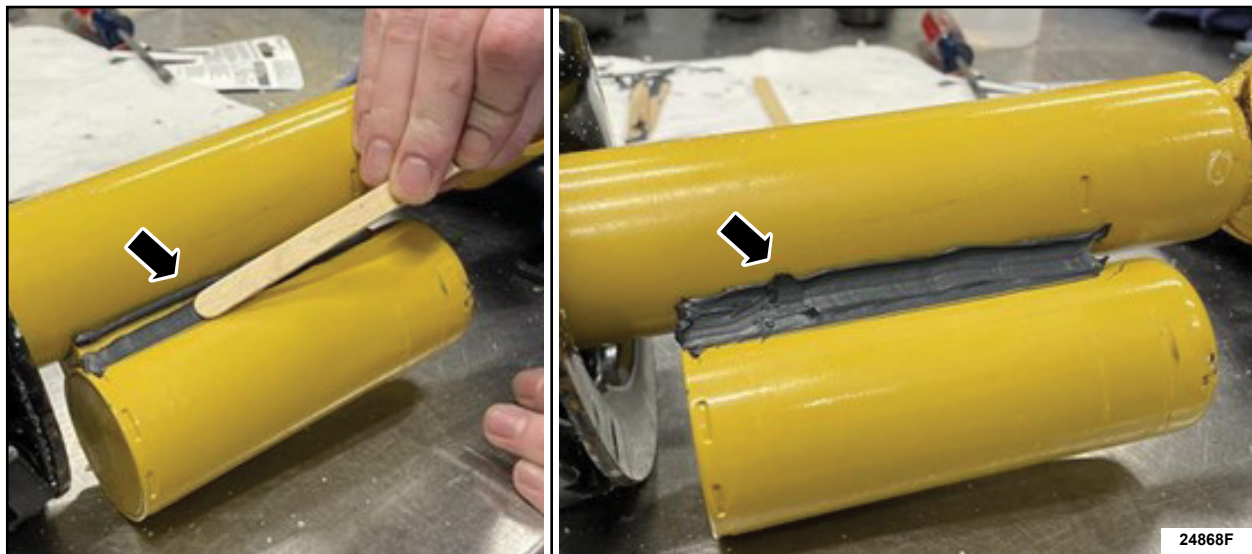

**FIGURE 8**

8. On both sides, use a smooth, rounded edged tool, such as a plastic trim tool or popsicle stick to smooth sealant along the edges. Make sure the sealant fully encapsulates the shock to reservoir flanges. See Figure 9.

**NOTE:** On all sides, make sure the interface between the flange and the reservoir is fully sealed. Make sure the interface between flange and damper main body is fully sealed.

**NOTE:** Rear shock removed for clarity.



**FIGURE 9**



9. On both sides, position the *new* shock absorber reservoir retention clamp/shield around the shock and reservoir as shown in Figure 10. Make sure of the correct orientation by using the UP arrow on the shield and the attachment holes are facing the rear of the vehicle.

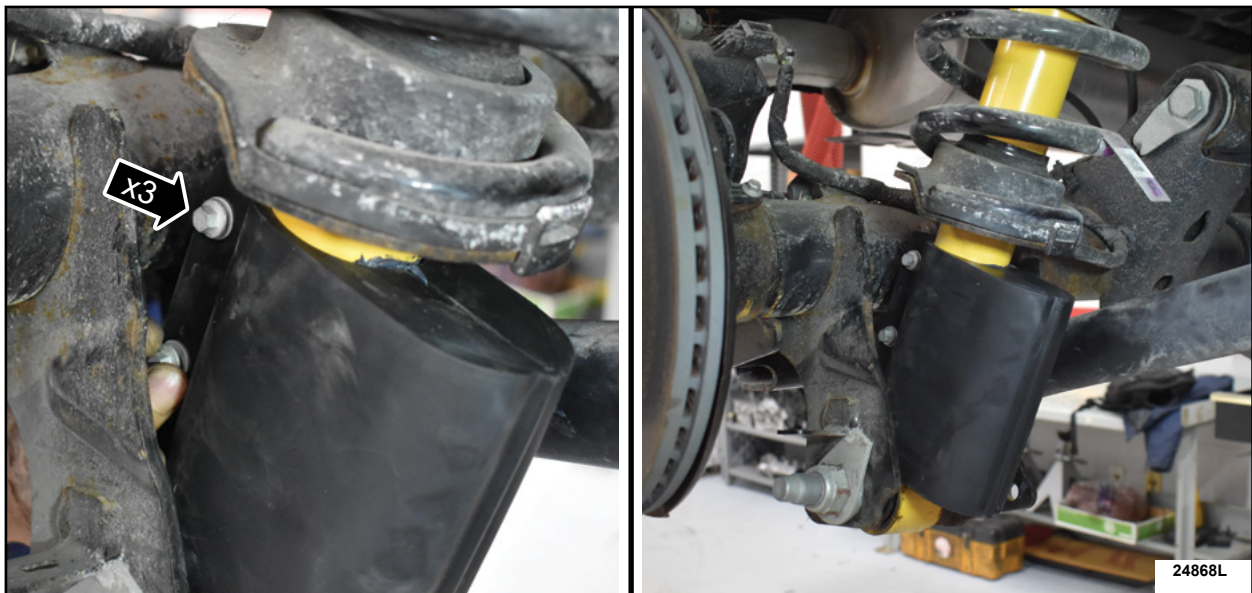

**FIGURE 10**

10. On both sides, using the bolts and nuts in the service kit, secure the shock absorber reservoir retention clamp/shield as shown in Figure 11.

- Torque to: 7 lb.ft (10 Nm).

**NOTE:** It may be necessary to use a torque wrench adapter when torquing the bolts. Refer to the Torque Wrench Adapter Formulas under Quick Links in the Workshop Manual for your style of adapter.



**FIGURE 11**



11. On both sides, clean off any excess sealant that may be exposed from installing the shock absorber external reservoir retention clamp/shield. See Figure 12.



**FIGURE 12**

12. Install both rear tires. Follow the WSM procedures in Section 204-04. This completes the FSA.

**IMPORTANT NOTE:** Federal law prohibits selling motor vehicle parts or components that are under safety, compliance, or emissions recall. Unless a part is requested to be returned to Ford, all parts replaced under this FSA must be scrapped in accordance with all applicable local, state and federal environmental protection and hazardous material regulations. Refer to the Parts Retention, Return, & Scrapping section of the FSA dealer bulletin for further information.



## PHOTO REQUEST SUBMISSION (SSSC PHOTO SUBMISSION)

Ford has requested photo evidence prior to performing the repair for the FSA.

The SSSC must provide approval prior to performing the repair.

1. Contact the SSSC and upload the necessary photos or copy of documentation(s) as an attachment for review.

- A photo of the VIN tag.
- A photo of the Repair Order (RO).
- A photo of the failed rear shock absorber(s). See Page 10.

2. There are two ways to submit the requested items to SSSC.

- a. Directly in the SSSC contact request form while submitting your contact on your desktop.
- b. Via PTS Mobile under the Images/Files Upload menu selection. Select SSSC in the sub-menu and ensure your P&A code is correct. Upload the item(s) by selecting the appropriate FSA with the option to use a prior contact ID. The item(s) will be associated with your SSSC contact during submission.

**NOTE:** If you have not submitted an SSSC contact yet, then you can still upload the item(s) via PTS mobile, and the item(s) will be available when opening your SSSC contact for this VIN and recall.

3. Upon approval, the SSSC will provide an approval code that must be used for claiming.



### Photo Requirement Examples

Acceptable Photos: Clearly shows the area of damage or failure.

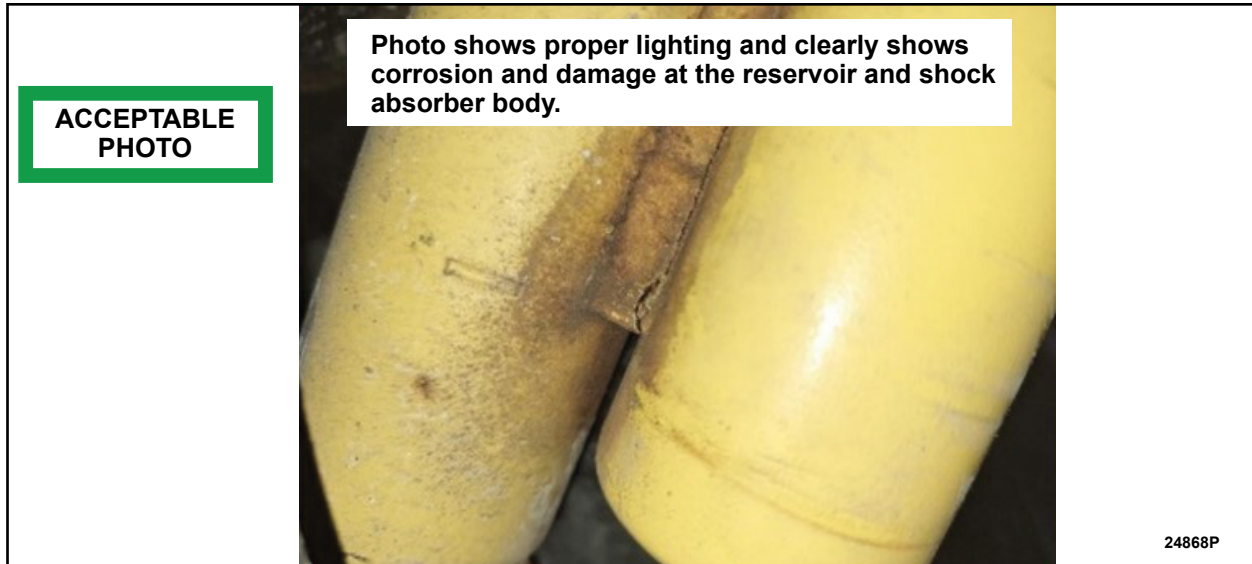

**FIGURE 13**

Unacceptable Photos: Is not clear or does not show the area of damage or failure.



**FIGURE 14**



25S01 – Supplement #1

## Vehicle Pick-Up and Delivery Record

VIN \_\_\_\_\_ received (check one):

Pick-up and/or delivery service

As outlined below for the 25S01 Field Service Action program.

Pick-up – Date: \_\_\_\_\_

Delivery – Date: \_\_\_\_\_

\_\_\_\_\_  
Repair Order #

\_\_\_\_\_  
Repair Order Date

\_\_\_\_\_  
Service Manager Signature

\_\_\_\_\_  
Date

**Ford Motor Company**  
**Recall Reimbursement Plan for 25S01 – Supplement #1**

*Ford and Lincoln dealers are in the best position to quickly and efficiently process reimbursement requests. However, federal legislation requires all motor vehicle manufacturers to establish processes through which customers may seek recall reimbursement directly from the manufacturer or the dealers.*

*Regarding the specific reimbursement plan for Recall # 25S01, owners who have paid for service to remedy the defect or noncompliance must have had that service performed before August 15, 2025. After this date, if repairs related to this recall are performed by a non-Ford repair facility in an emergency, customers must submit any refund requests through their dealership. As required by this federal regulation, Ford Motor Company submitted the details of its latest General Recall Reimbursement Plan in a letter to the National Highway Traffic Safety Administration (NHTSA) in May 2025. The following is the text of that letter and the Plan:*

**General Recall Reimbursement Plan**  
(As submitted to the NHTSA)

Pursuant to the requirements set forth in 49 CFR Part 573 and Part 577 of the Code of Federal Regulations, Ford Motor Company (Ford) is submitting required information pertaining to our general reimbursement plan for the cost of remedies paid for by vehicle owners before they are notified of a related safety recall.

Set forth below is Ford's general plan to reimburse owners and purchasers for costs incurred for remedies in advance of notification of potential safety-related defects or non-compliances pursuant to Part 573.6 (c)(8)(i). This plan has not changed since our May 21, 2025 submission.

Reimbursement Notification

Ford's notice to a vehicle owner in accordance with 49 CFR Part 577 will indicate that Ford is offering a refund if the owner paid to have service to remedy the defect or noncompliance prior to a specified ending date. In accordance with Part 573.13 (c)(2), this ending date will be defined as a minimum of ten calendar days after the date on which Ford mailed the last of its Part 577 notifications to owners and will be indicated in the specific reimbursement plan available to owners for an individual recall. This notice will direct owners to seek eligible reimbursement through authorized dealers or, at their option, directly through Ford at the following address:

Ford Motor Company  
P.O. Box 6251  
Dearborn, MI 48121-6251

Ford notes that this rule allows for the identification of a beginning date for reimbursement eligibility. Under the rule, an owner who paid to remedy the defect or noncompliance prior to the identified beginning date would not be eligible for reimbursement. Ford generally has not established such a beginning date for reimbursement eligibility and does not presently anticipate changing this general policy. However, in any case where Ford determines a beginning date is appropriate, Ford will indicate that date in the owner notice. As permitted by 577.11(e), Ford may not include a reimbursement notification when all vehicles are well within the warranty period, subject to approval by the Agency.

## Costs to be Reimbursed

For vehicles, reimbursement will not be less than the lesser of:

- The amount paid by the owner for the remedy that specifically addressed and was reasonably necessary to correct the defect or noncompliance that is the subject of the recall, or
- The cost of parts for the remedy (to be no more than the manufacturer's list retail price for authorized part(s), plus associated labor at local labor rates, miscellaneous fees (such as disposal of waste) and taxes.

For replacement equipment, reimbursement will be the amount paid by the owner for the replacement item (limited by the amount of the retail list price of the defective or noncompliant item that was replaced, plus taxes, where the brand or model purchased by the owner was different than the brand or model that was the subject of the recall). If the item of motor vehicle equipment was repaired, the reimbursement provisions identified above for vehicles will apply.

Ford notes that costs incurred by the owner within the period during which Ford's original or extended warranty would have provided for a free repair of the problem will not be eligible for reimbursement, as provided by Part 573.13 (d)(1).

## Entities Authorized to Provide Reimbursement

Ford will continue to use authorized dealers to reimburse owners under the specific reimbursement plans for a particular recall and will encourage owners to pursue requests for reimbursement directly through dealers to expedite reimbursement. Ford will also provide a mailing address to which customers can, at their option, send requests for reimbursement directly to Ford, as previously noted. Requests for reimbursement sent directly to Ford may take up to 60 days to process. Whether the owner chooses to pursue reimbursement requests through a dealer or directly through Ford, the owner will be directed to submit the required documentation, upon which reimbursement eligibility will be determined.

## Required Documentation

The reimbursement determination will depend upon the information provided by the customer. Consistent with Part 573.13 (d)(4) the following information must be submitted:

- Claimant name and address
- Vehicle make, model and model year
- Vehicle identification number (VIN) and, for replacement equipment, a description of such equipment or, for tires, the model, size and TIN (DOT code)
- Identification of the recall number (either the Ford recall number or the NHTSA recall number)
- Identification of the owner of the recalled vehicle at the time that the pre-notification remedy was obtained
- An original receipt for the pre-notification remedy that includes a breakdown of the amount for parts, labor, other costs and taxes, including costs for the replacement item. Where the receipt covers work other than to address the recall or noncompliance, Ford may require the claimant to separately identify costs that are eligible for reimbursement.
- If the remedy was obtained during the warranty repair did not correct the problem related to the recall

Failure to submit all the above information may result in denial of the reimbursement request.

### Additional Information

The Part 577 required owner notice will provide a toll-free telephone number through which specific information about the reimbursement plan can be requested from Ford. This general reimbursement plan will be incorporated into notifications pursuant to Part 573.6 by reference. Information specific to an individual recall also may be incorporated into the Part 573.6 notification.