



Safety Recall Action Notice 627 Issue 1 - 10/2024

Subject: Alternator Connector Wire Alignment Clip			
Bulletin Number	Models Affected	VIN Range	Markets Affected
627	Bonneville T100	From VIN AC5927 to VIN BT0222	All Markets
	Bonneville T120	From VIN AC6130 to VIN BT0226	
	Bonneville T120 Black	From VIN AD0139 to VIN BT0240	
	Street Scrambler	From VIN AB9837 to VIN BE2907	
	Scrambler 900	From VIN BC1952 to VIN BT0238	
	Street Twin	From VIN AB9715 to VIN BE2977	
	Speed Twin 900	From VIN BA4140 to VIN BT0245	
	Street Scrambler Sandstorm	From VIN AD1924 to VIN AG5772	
	Street Twin Goldline	From VIN AD5910 to VIN AV9996	

Background Information

Dealers are requested to fit a new wire alignment clip that has been introduced for the wires entering the female connector of the alternator lead.

The procedure for installing the clip is described below.

Customer Contact Instructions

NOTICE

STOP DELIVERY OF AFFECTED MOTORCYCLES IMMEDIATELY.

DO NOT deliver a motorcycle affected by this Safety Recall Action Notice to a customer until you have completed, or confirmed completion of, the procedures described in this Safety Recall Action Notice.

Delivering a motorcycle subject to an outstanding Safety Recall Action Notice may contravene local or national laws in your market, territory or country.

Triumph subsidiaries and distributors must instigate a Safety Recall Action in their country in accordance with the national recall code of practice. For vehicles in dealer stock, the safety recall MUST be actioned before delivery to the customer.

Dealers are to prioritise repair of customer owned motorcycles before any unsold motorcycles.

Identification of Affected Motorcycles

Bonneville T100, Bonneville T120, Bonneville T120 Black, Street Scrambler, Scrambler 900, Street Twin, Speed Twin 900, Street Scrambler Sandstorm and Street Twin Goldline motorcycles as described in the table above.

Warranty Claim Instructions

Bulletin Number	Fault Code	Repair Code	Description	Repair Time Allowance
627	025040915	99615	Fit alternator connector wire alignment clip	0.08

Genuine Parts Information

Bulletin Number	Model	Part Number	Description	Quantity
627	Bonneville T100, Bonneville T120, Bonneville T120 Black, Street Twin, Speed Twin 900, Street Twin Goldline	T2504846	Spares Kit, Clip, Cables, Triple Consisting of: Clip, Cables, Triple, MLDG - Qty 1 Screw, PAN/HD, TX M5x0.8x16, ENC - Qty 1	1
627	Street Scrambler, Scrambler 900, Street Scrambler Sandstorm	T2504847	Spares Kit, Clip, Cables, Triple Consisting of: Clip, Cables, Triple, MLDG - Qty 1 Screw, PAN/HD, TX M6x1.0x16, ENC - Qty 1	1

Parts Ordering Instructions

For Triumph Subsidiary and Overseas Distributor dealers using Triumph Warranty On-Line with Parts Auto Ordering Flag switched on: Order all repair parts by submitting a New Prior through the Warranty On-Line system. Entering the above repair code in a New Prior will automatically add the parts required and labour times for this Safety Recall Action Notice.

For Overseas Distributor dealers NOT using Triumph Warranty On-Line or for Overseas Distributor dealers using Triumph Warranty On-Line with Parts Auto Ordering Flag switched off: Orders should be placed using the normal parts ordering procedure.

Genuine Parts Return

Dealer to retain parts for 90 days. All parts must be stored in a secure, non-public accessed area and correctly identified with a completed warranty label. Thereafter the parts must be rendered unusable prior to scrapping.

Other Instructions

Once completed, please mark the Service Record Book that the requirements of this Safety Recall Action Notice have been complied with.

Before returning the motorcycle to the customer, check that all electronic control modules have the latest latest calibrations installed using the latest version of the Triumph Diagnostic Tool. Download any updates as necessary.

⚠ WARNING

Make sure the motorcycle is stabilised and adequately supported.

Do not support the motorcycle on any ancillary component, the exhaust system or any other non structural parts of the motorcycle frame.

A correctly supported motorcycle will help prevent it from falling.

Failure to follow the advice above could result in serious injury or death.

⚠ CAUTION

If the motorcycle has recently been running, some components may be hot to the touch.

Contact with the hot components may cause damage to exposed skin.

To avoid skin damage, always allow the hot parts to cool before working on the motorcycle.

Fitting the Alternator Connector Wire Alignment Clip

NOTICE

Note the position of the electrical connectors for installation.

1. Remove the battery as described in the service manual.
2. Remove the side panel by grasping the panel firmly in both hands and pulling the panel away from the motorcycle until it clears the three retaining grommets (leaving the grommets in place).

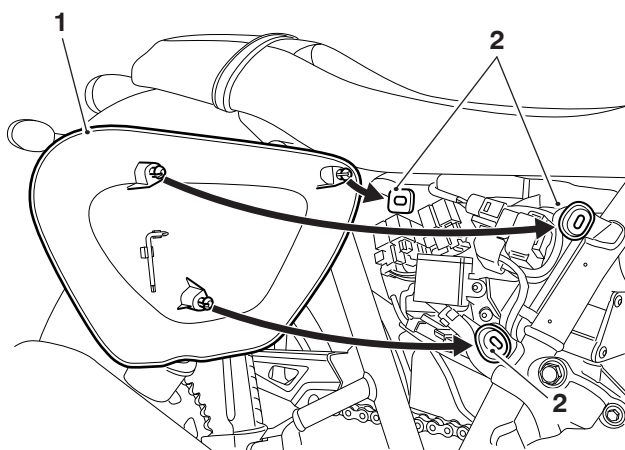

1. Side panel (right hand shown)
2. Grommets

NOTICE

To prevent paint damage, do not spill brake fluid onto any area of the bodywork. Spilled brake fluid will damage paintwork.

3. Remove and discard the rear brake fluid reservoir fixing and detach the rear brake fluid reservoir from the relay bracket. Secure the rear brake fluid reservoir in an upright position.

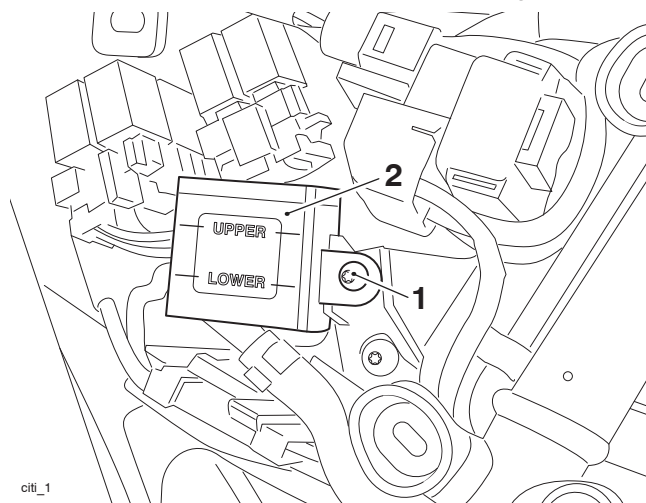

1. Fixing
2. Brake fluid reservoir

4. Detach the alternator connector from the relay bracket. Disconnect the alternator electrical connector from the main harness.

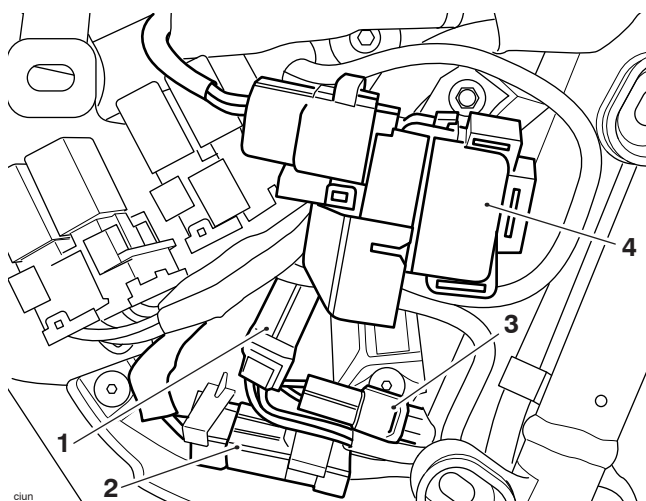

1. Gear position sensor multiplug
2. Alternator connector
3. Crankshaft position sensor multiplug
4. Starter motor solenoid

5. Carefully pull the alternator connector from the relay bracket such that the alternator connector wires are visible and inspect the alternator connector for damage. If damage is found, contact Triumph service. If no damage is found, proceed to the next step.

NOTICE

Make sure the alternator wires are not twisted before fitting the wire alignment clip.

6. Install the clip on the alternator connector wires in the orientation shown such that the two wire openings are facing upwards when the clip is installed and the alternator connector is connected back to the main harness.

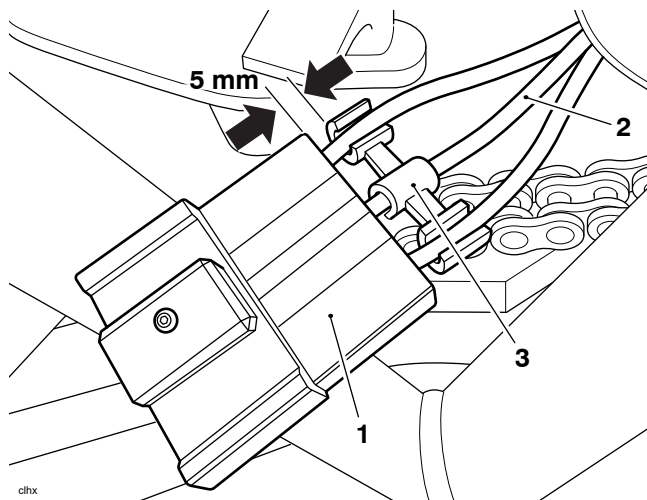

1. Alternator connector
2. Alternator wires
3. Wire alignment clip

7. Slide the wire alignment clip as close as possible to the female connector. The maximum permitted gap between the clip and the alternator connector is 5 mm.

NOTICE

Make sure the alternator wires are not twisted when reconnecting it back to the main harness.

8. Reconnect the alternator connector back to the main harness. Attach the alternator connector to the relay bracket.
9. Refit the brake fluid reservoir to the frame, and tighten the new fixing to 3 Nm.

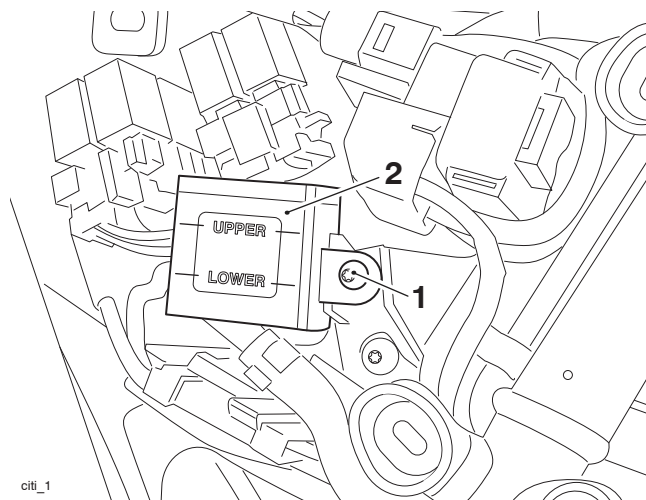

1. Fixing
2. Brake fluid reservoir

-
10. Refit the side panel by positioning the three locating dowels to the grommets and pressing firmly to secure the panel.

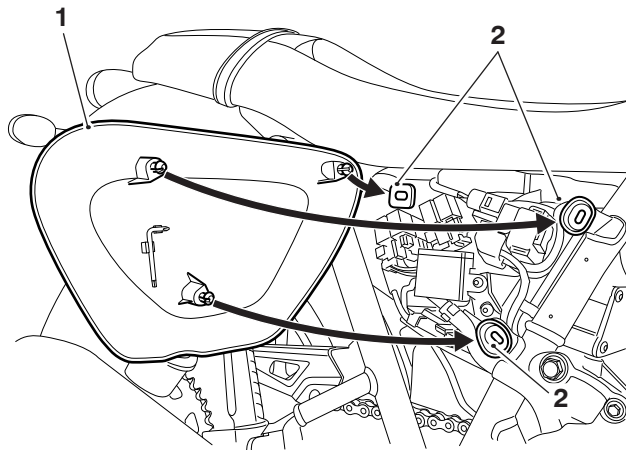

1. Side panel (right hand shown)

2. Grommets

11. Grasp the panel and make sure that it is fully retained.
12. Install the battery as described in the service manual.