

November 07, 2025

Version 4

Safety Recall: 2023–25 Multi-Model High Pressure Fuel Pump Leak

Supersedes Version 3, dated January 17 2025, to revise the information.

APPLIES TO

Year	Model	Trim Level	VIN Range
2023–24	Accord Hybrid	ALL	Check VIN status in iN for eligibility.
2025	Civic Hybrid	ALL	Check VIN status in iN for eligibility.
2023–25	CR-V Hybrid	ALL	Check VIN status in iN for eligibility.

REVISION SUMMARY

- Under PARTS INFORMATION, parts ordering restriction information was removed.
- Under Test the High-Pressure Fuel Pump for Hydrocarbons, parts ordering information was updated.

BACKGROUND

American Honda is announcing a **STOP SALE** and **safety recall** for certain model year 2023–24 Accord Hybrid, 2025 Civic Hybrid, 2023–25 CR-V Hybrid vehicles which may have improperly manufactured high-pressure fuel pumps.

A high-pressure fuel pump which was manufactured improperly can cause the fuel pump to fracture, leading to a fuel leak. A fuel leak in the presence of an ignition source may increase the risk of a fire or injury.

CUSTOMER NOTIFICATION

Owners of affected vehicles will be sent a notification of this safety recall. Do an iN VIN status inquiry to verify eligibility. Some vehicles affected by this campaign may be in your new or used vehicle inventory.

Failure to repair a vehicle subject to a recall or campaign may subject your dealership to claims or lawsuits from the customer or anyone else harmed as a result of such failure. To see if a vehicle in inventory is affected by this safety recall, do a VIN status inquiry before selling it.

Suggested Verbiage to be Included on the Repair Order

Customer was advised that:

The vehicle is subject to a recall affecting the high-pressure fuel pump. The inspection process has determined the pump has a leak. However, the parts necessary to complete the repair are currently unavailable. Vehicles with a leaking high-pressure fuel pump will be held until parts are available, and a loaner vehicle will be provided. Vehicles are eligible for immediate repair once parts are available, and the dealer will notify the customer.

CORRECTIVE ACTION

- **Vehicles fewer than 700 miles:** Check the 12-volt battery, perform the idle test procedure, then test the high-pressure fuel pump for a leak. Replace the high-pressure fuel pump if a leak is detected.
- **Vehicles 700 or more miles:** Test the high-pressure fuel pump for a leak. Replace the high-pressure fuel pump if a leak is detected.

CUSTOMER INFORMATION: The information in this bulletin is intended for use only by skilled technicians who have the proper tools, equipment, and training to correctly and safely maintain your vehicle. These procedures should not be attempted by “do-it-yourselfers,” and you should not assume this bulletin applies to your vehicle, or that your vehicle has the condition described. To determine whether this information applies, contact an authorized Honda automobile dealer.

WARRANTY CLAIM INFORMATION

Vehicles with 700 or More Miles

NOTE:

- For templates A, B, C, or D, the odometer must read **700 or more miles**.
- For templates C or D, open a **second repair line** for the fuel pump replacement.

Operation Number	Description	Flat Rate Time	Defect Code	Symptom Code	Template ID	Failed Part Number
1215A7	Inspect high-pressure fuel pump for hydrocarbons. NO LEAK FOUND. No further action required.	0.4 hr	6YP00	QK800	A24049A	16790-6MA-J01
1215A8	Inspect high-pressure fuel pump for hydrocarbons. HIGH PRESSURE FUEL PUMP IS LEAKING	0.4 hr	6YP00	QK800	A24049B	16790-6MA-J01
1211PC	Civic Hybrid: Replace high pressure fuel pump	1.7 hr	6YP00	QK800	A24049C	16790-6MA-J01
1211PC	Accord Hybrid, CRV Hybrid: Replace high pressure fuel pump	1.5 hr	6YP00	QK800	A24049D	16790-6MA-J01

Vehicles with Fewer Than 700 Miles

NOTE:

- For templates E, F, G or H the odometer must read **fewer than 700 miles**.
- For templates G or H, **open a second repair line** for the fuel pump replacement.
- After completion of the idle test, a warranty code will be generated. Please clearly note the warranty code on the repair order. When submitting a warranty claim, enter the code in the test code field of the claim form. To retrieve a warranty code, go through Honda Diagnostic Cloud Website, select AHM SSO and use your log in credentials.
- The gasoline consumed during the idle test procedure, under the inspection procedure, can be claimed up to \$25. Enter the amount under templates E or F, and sublet code O1.

Operation Number	Description	Flat Rate Time	Defect Code	Symptom Code	Template ID	Failed Part Number
1215B0	Do idle test procedure then test for hydrocarbons. NO LEAK FOUND. No further action required.	1.0 hr	6YP00	QK800	A24049E	16790-6MA-J01
1215B1	Do idle test procedure then test for hydrocarbons. HIGH PRESSURE FUEL PUMP IS LEAKING	1.0 hr	6YP00	QK800	A24049F	16790-6MA-J01

1211PD	Civic Hybrid: Replace high pressure fuel pump	1.7 hr	6YP00	QK800	A24049G	16790-6MA-J01
1211PD	Accord Hybrid, CRV Hybrid: Replace high pressure fuel pump	1.5 hr	6YP00	QK800	A24049H	16790-6MA-J01

PARTS INFORMATION

NOTE: The affected volume of vehicles is expected to be low. If a High Pressure Fuel Pump Assy. Service Kit is needed, order through the normal VIN Control Parts Ordering Program.

Part Name	Part Number	Quantity
High Pressure Fuel Pump Assy. Service Kit	06161-6MA-305	1

TOOL INFORMATION

Tool Name	Tool Number	Quantity
Hydrocarbon Tester and Caps (3)	07AAJ-001A100	1
Honda Antares Capsule	BSEHAC001	1

INSPECTION PROCEDURE

- If the vehicle has **700 or more miles**, test for hydrocarbons at the high-pressure fuel pump. If it fails the test criteria, replace the high-pressure fuel pump.
- If the vehicle has **fewer than 700 miles**, do the Idle Test procedure, then test for hydrocarbons at the high-pressure fuel pump. If it fails the test criteria, replace the high-pressure fuel pump.

⚠ WARNING

Carbon monoxide gas is toxic and can rapidly accumulate in closed or even partly enclosed areas. Breathing in carbon monoxide gas can cause unconsciousness and even death. **Never** leave the vehicle on while parked in a garage or other areas with limited ventilation!

- A fuel leak in the presence of an ignition source may ignite and cause a fire.
- Verify the vehicle is in PARK prior to conducting the INSPECTION PROCEDURE.
- Leaving the key in the vehicle may result in the theft or other accidental movement of the vehicle. Make sure the key is in a safe location for **any** period during which the observation period of the INSPECTION PROCEDURE is conducted.
- Vehicles should be idled during the INSPECTION PROCEDURE in an open area, away from occupied locations and structures while still under the supervision of appropriate dealership personnel. The vehicle should be assessed at regular intervals to confirm correct operation. **Failure to do so** may result in the theft, and/or other damages to the vehicle as well as harm to individuals.
- Dealerships must comply with all other applicable laws and regulations whether federal, state, or local before and during completion of both the INSPECTION PROCEDURE and REPAIR PROCEDURE.

For vehicles with 700 or more miles, go to [Test the High-Pressure Fuel Pump for Hydrocarbons](#).

Idle Test Procedure (For vehicles with fewer than 700 miles)

1. Confirm the 12-volt battery is in good condition, see October 2024 Service News [Long Term Maintenance and Care for Vehicles in Dealer Inventory](#).
2. Start the engine.
3. Enter [PGM-FI System Maintenance Mode](#)-Procedure
4. Make sure the A/C is turned OFF to prevent the radiator fan from running.
5. With the engine running, visually check the solenoid area of the high-pressure pump for fuel leakage.

Is fuel leakage visible?

Yes – 1. Turn the vehicle to OFF mode.

2. Go to **step 11** of the [Test the High-Pressure Fuel Pump for Hydrocarbons](#) section and scan the QR code to order a replacement high-pressure fuel pump (No further testing required).

No – Proceed to the next step.

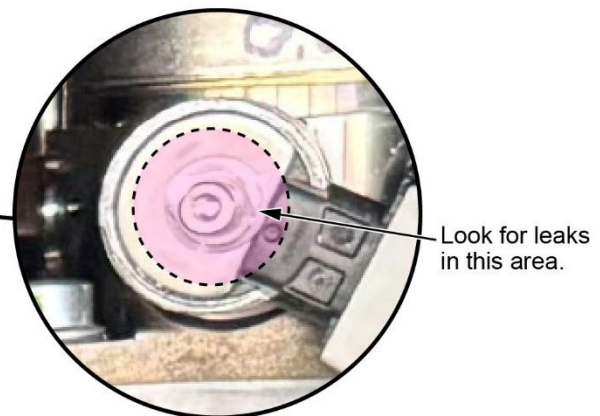

6. Turn the vehicle to the OFF mode.
7. Read through the entire procedure fully before continuing with the inspection procedure.
8. Connect the Honda Antares Capsule (HAC) to the data link connector (DLC).

NOTE:

- Make sure your Honda Antares Capsule is registered and configured for Wi-Fi or mobile hotspot. Click here for more information: [Honda Antares Capsule Registration and Configuration](#) quick start guide.
- **Do not** use the USB cable from the capsule for this test.
- Technical assistance for the Honda Antares Capsule (HAC) and i-HDS related applications is provided by the American Honda Special Tools Hotline at 1-833-949-4672.
Hours of operation are Monday to Friday, 7 AM to 5 PM Pacific Time.

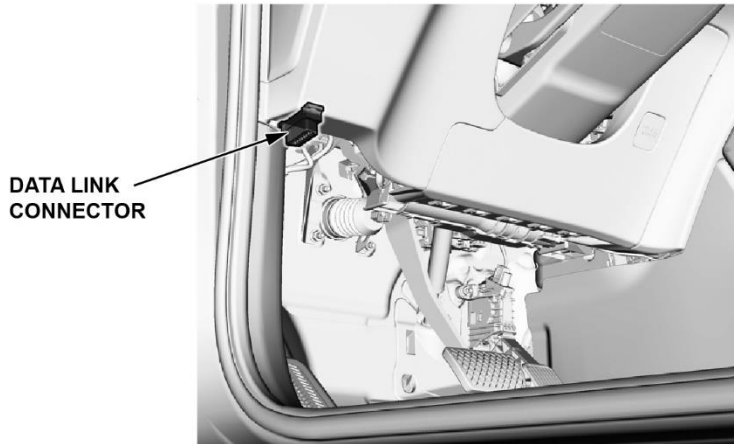

9. Start the engine.
10. Launch the Honda Diagnostic Cloud (HDC) website – <https://hondadiagnostics.com>
11. Select US Dealer.
12. Login using iN credentials.
13. On the Connected Vehicles screen, in the VCI ID column, find the serial number for the HAC you will be using, and click to select.
14. Change the HAC VCI mode from Diagnostic Mode to Campaign Mode by clicking on the Toggle VCI Mode button.

NOTE:

- Campaign mode is for this procedure only. **For all other uses**, switch back to Diagnostic Mode by clicking the Toggle VCI Mode button.
- Tip: The Launch HPFP App button will only appear when you select a HAC configured for Campaign mode.

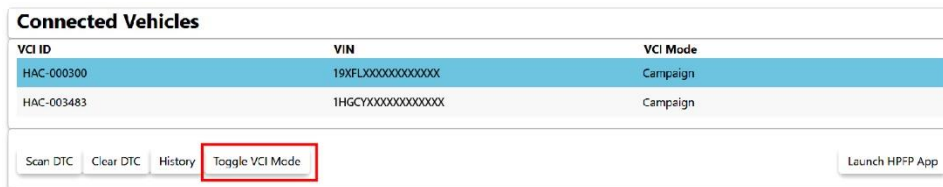

15. Click on the Launch HPFP App button.

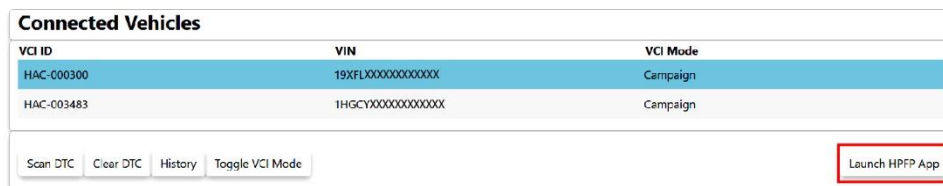

16. From the HP Fuel Pump Leak Pretest screen, select the Start New Pretest button

HP Fuel Pump Leak Pretest

This pretest procedure is completed in 3 steps :

1. Precondition the vehicle and let the engine idle for up to 13 hours
2. Return to confirm completion of engine idle phase
3. Prepare engine for Fuel Pump Leak Test

Before proceeding, your Honda Antares Capsule must be:

- Connected to the vehicle's DLC port
- Connected to your dealer's Wi-Fi network or mobile hotspot
- Configured for "Campaign Mode" on HDC

Select an option to continue :

Start New Pretest

Resume / Finish / Confirm Pretest

17. Confirm the Honda Antares Capsule ID, VIN, and Vehicle are correct, then click Next.

NOTE: If the VIN is not part of this campaign or the odometer value exceeds the test parameters, you will receive a notification.

HAC and VIN

Honda Antares Capsule ID:	HAC-000300
VIN :	19XFLXXXXXXXXXX
Vehicle:	2025 Honda CIVIC HYBRID

Back

Next

18. Prepare the vehicle for the test:

NOTE: **Do not** place the hybrid vehicle in maintenance mode. Running the vehicle in maintenance mode for long periods of time may damage the high voltage battery.

1. Ensure the fuel level is above 50%, but do NOT top off the tank.
2. Confirm the hood is completely closed and latched.
3. Confirm the engine is running (ready to drive mode).
4. Driver's seat belt is buckled.
5. Headlight High Beams are ON.

NOTE: The app will detect all conditions, except those that are HVAC related. Manually confirm those conditions by selecting the **Click to Confirm** buttons

6. A/C is ON.
7. Heater is on HI
8. A/C blower on MAX.

VIN : 1HGCVXXXXXXXXXXXXX
Vehicle : 2025 Honda ACCORD HYBRID

Preconditions :

1. Ensure the fuel level is above 50% to allow a runtime of 13 hours
2. Confirm the Hood is Closed
3. Start the vehicle
4. Turn the HEADLIGHT HIGH BEAM ON
5. Turn the A/C ON with HEATER on HI & BLOWER on MAX
6. Buckle the Driver's Seat Belt to prevent engine auto shut off

CAUTION: Do NOT place the hybrid vehicle in maintenance mode

		Conditions Met?
Fuel Level :	<input type="text" value="93.333 %"/>	✓
Hood CLOSED :	<input type="text" value="Yes"/>	✓
Driver's Seatbelt BUCKLED :	<input type="text" value="Yes"/>	✓
Headlight Highbeams ON :	<input type="text" value="On"/>	✓
A/C On :	<input type="button" value="Click To Confirm"/>	✓
Heater On HI :	<input type="button" value="Click To Confirm"/>	✓
A/C Blower MAX :	<input type="button" value="Click To Confirm"/>	✓

After all conditions are met, click **Next** to proceed

Click to start the test.

19. Select Next to start the test.

NOTE: The test cannot proceed if any of the conditions are not met.

20. Let the engine idle for up to 13 hours in a safe and monitored location.

VIN : 1HGCVXXXXXXXXXXXX	Hybrid
Vehicle : 2025 Honda ACCORD HYBRID	
LET ENGINE IDLE FOR UP TO THIRTEEN(13) HOURS	
The pretest session information has been saved. Please select "Resume / Finish / Confirm Pretest" with the HAC VCI connected to both a Wi-Fi network and the vehicle to reopen the session from the Main Menu.	
You may now disconnect the HAC VCI and then return for confirmation after the required time has elapsed.	
You may reposition the vehicle on dealer property, but excessive driving will void the pretest and all progress will be lost.	
Session start time : 2024-11-14 17:46	
Approximate finish time : 2024-11-15 06:46	
The vehicle needs to run up to 13 hours. If absolutely necessary, you may turn off the engine and resume the Engine Idle Phase from where you left off. To do so, select Resume Pretest from the Main Menu.	
Do not add more fuel to the tank. Adding fuel after the pretest starts will void the pretest and all progress will be lost.	
<input type="button" value="Return to Main Menu"/>	<input type="button" value="Close"/>

21. The HAC can be removed at this time for use on other vehicles.

NOTE: If the engine idle phase must be interrupted by turning off the engine, the test can be resumed by following the instructions below.

Resuming a Test or Confirming its Status

- Used when reconnecting to check test status.
- Used when resuming a test if the vehicle was turned off and the test was paused.

22. Connect the HAC to the DLC.

23. With the vehicle running in ready to drive mode, repeat steps 9 through 14 to reconnect to the vehicle.

NOTE: If the HAC is already in Campaign mode, skip step 13.

24. Resume or Confirm the test by selecting the Resume / Finish / Confirm Pretest button.

HP Fuel Pump Leak Pretest	
This pretest procedure is completed in 3 steps :	
1. Precondition the vehicle and let the engine idle for up to 13 hours	
2. Return to confirm completion of engine idle phase	
3. Prepare engine for Fuel Pump Leak Test	
Before proceeding, your Honda Antares Capsule must be:	
<ul style="list-style-type: none">• Connected to the vehicle's DLC port• Connected to your dealer's Wi-Fi network or mobile hotspot• Configured for "Campaign Mode" on HDC	
Select an option to continue :	
<input type="button" value="Start New Pretest"/>	<input type="button" value="Resume / Finish / Confirm Pretest"/>

27. Verify the preconditions are met. After selecting Next, follow the on-screen instructions and return to step 21 after the remaining time has elapsed.

VIN :
Vehicle :

Preconditions :

1. Confirm the Hood is Closed
2. Start the vehicle
3. Turn the HEADLIGHT HIGH BEAM ON
4. Turn the A/C ON with HEATER on HI & BLOWER on MAX
5. Buckle the Driver's Seat Belt to prevent engine auto shut off

CAUTION: Do NOT place the hybrid vehicle in maintenance mode.

		Conditions Met?
Hood CLOSED :	<input type="text" value="Yes"/>	✓
Driver's Seatbelt BUCKLED :	<input type="text" value="Yes"/>	✓
Headlight Highbeams ON :	<input type="text" value="Off"/>	✗
A/C On :	<input type="button" value="Click To Confirm"/>	✓
Heater On HI :	<input type="button" value="Click To Confirm"/>	✓
A/C Blower MAX :	<input type="button" value="Click To Confirm"/>	✓

28. Engine temperature must be above 176°F / 80°C to proceed. Click Next once the temperature is reached.

1. Ensure the Engine Coolant Temperature is above 176°F / 80°C

ECT in °F

Conditions Met? ✓

NOTE: If ECT is below the target temperature, place the vehicle into PGM-FI Maintenance Mode. HAC power will be lost momentarily, returning you to the Resume Test screen. Reselect VIN and proceed through previous steps to return to this screen.

29. Once the Idle Test has completed, proceed to test the fuel pump for hydrocarbons.

NOTE:

- The warranty code only indicates that the idle test has been completed, the hydrocarbon test using the HC tester must still be performed.

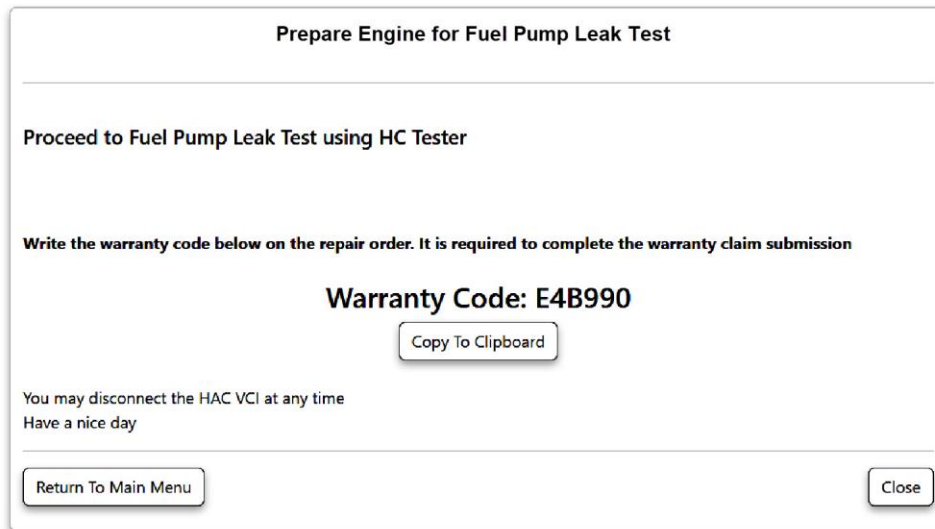

30. In humid areas water may accumulate in the exhaust. Place the vehicle into PGM-FI maintenance mode and rev the engine **2-3 times**.

Test the High-Pressure Fuel Pump for Hydrocarbons

Click here to view the video:

▶ PLAY VIDEO

The video is verification the tester reads properly by checking the reading in the filler neck.

1. Remove the engine cover.
2. Verify the Hydrocarbon (HC) tester is operating properly:
 1. **With the engine OFF**, install the emergency funnel in the filler neck.

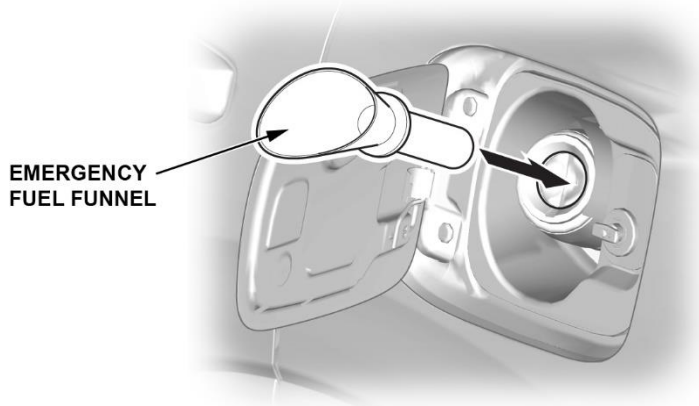

2. Turn on the HC tester by pressing and holding the power button for **3 seconds**. Once powered, the tester will perform a self-check and calibration. Confirm the measurement on the screen is showing 0. Allow the tester to warm up for **30 seconds** before use.

NOTE: If the screen does not show 0 after the self-check, the self-check **was not successful**. Repeat the power-up process. If the tester still does not show 0, switch to a known good tester.



3. **With the engine OFF**, insert the tip of the HC tester probe into the funnel and leave it there for up to **60 seconds**. If the tester produces a reading greater than 0, the tester is working; continue with the inspection process.



4. If there is no reading on the tester, switch to a different tester and repeat the verification process.
3. Connect the i-HDS to the data link connector located under the driver's side of the dashboard.

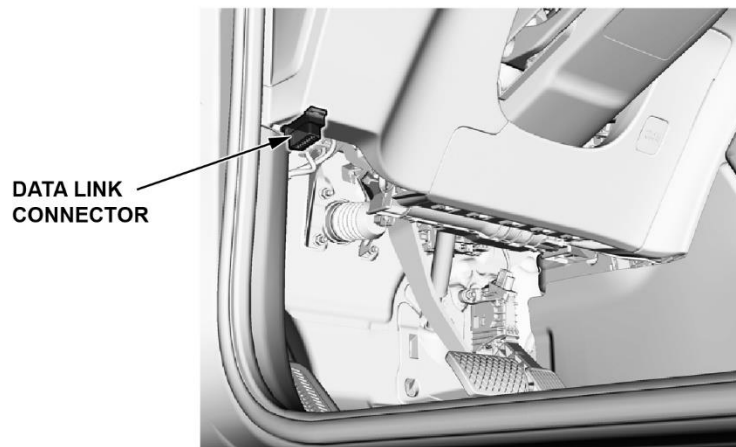

4. Enter PGM-FI System Maintenance Mode-Procedure

1. Turn the vehicle to the OFF (LOCK) mode.

NOTE: Do the following procedure within **60 seconds** to start the engine in the maintenance mode.

2. Turn the vehicle to the ON mode without stepping on the brake pedal.
3. With the transmission in the **PARK position/mode**, press the accelerator pedal the floor, **twice**.
4. Press the brake pedal, shift the transmission to the **NEUTRAL position/mode**, then press the accelerator pedal to the floor, **twice**.
5. Press the brake pedal, shift the transmission to **PARK position/mode**, then press the accelerator pedal to the floor, **twice**.
6. While pressing the brake pedal, press the power switch. The vehicle is now in the maintenance mode and the engine will start.
7. Confirm "Maintenance Mode" is displayed on the multi-information display.



5. Make sure the A/C is turned OFF to prevent the radiator fan from running.
6. Visually check the solenoid area of the high-pressure pump for fuel leakage.

Was fuel leakage visible?

Yes – 1. Turn the vehicle to OFF mode.

2. Order a **High-Pressure Fuel Pump Assy., Service Kit** (No further testing required).

No – Proceed to the next step.

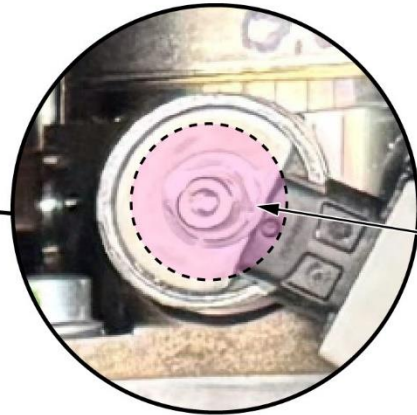

Look for leaks in this area.

7. Select **PGM-FI** from the i-HDS **System Selection Menu**. Use the i-HDS to monitor the engine rpm and engine coolant temperature (ECT Sensor 1).
8. Run the engine at **4,000 rpm** for **at least 80 seconds**, and until the engine coolant temperature (ECT Sensor 1) reaches **176°F**, then let the engine return to idle.

NOTE: The engine will go into fuel cut above **4,000 rpm**, try to keep RPM as close to **4,000** as possible.

▶ Vehicle Selection ▶ System Selection Menu ▶ PGM-FI ▶ Data List ▶

PGM-FI		
Signal	Value	Unit
Engine Speed	4213	RPM
Vehicle Speed	0	MPH
ECT Sensor 1 Voltage	0.69	V
ECT Sensor 1	185	°F

9. Hold the HC Tester probe to the test cap to verify that the test cap has no residual hydrocarbons. If there is a reading above 0 during the test, clean the test cap with soap and water and dry with a clean cloth.

NOTE: **Do not** use anything other than soap and water to clean the test cap.

10. Slide the test cap over the end of the HC tester probe and secure it with the locking nut.

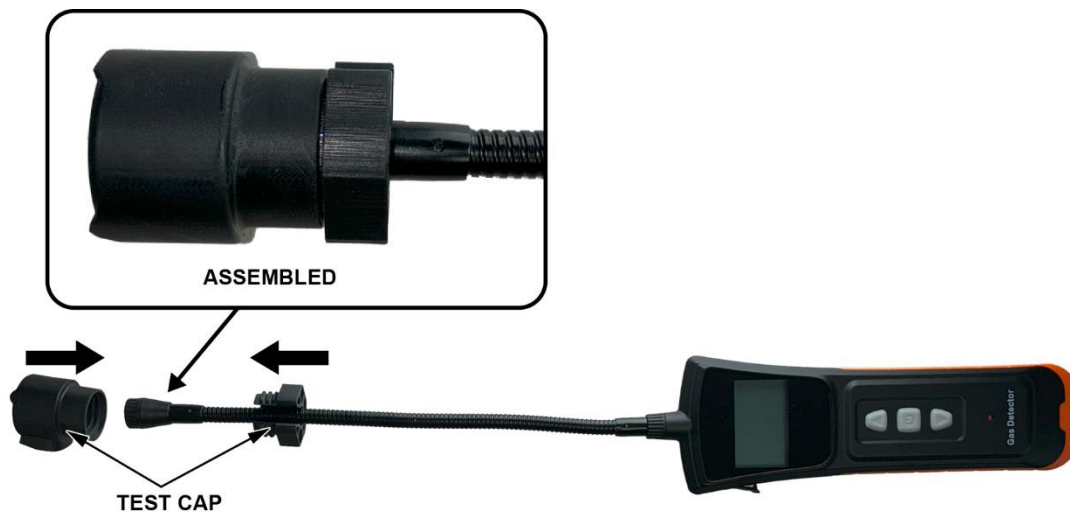

11. With the engine idling, attach the test cap on the HC tester to the high-pressure fuel pump solenoid. Make sure that the cutout in the test cap is aligned with the connector, then push to fully seat the cap. Leave the tester and test cap in place for **60 seconds** then check the reading on the display.

Install test cap here.

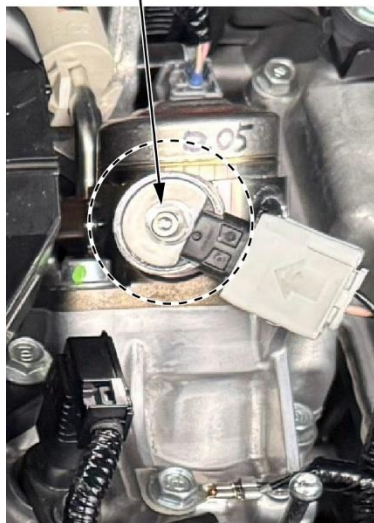

TEST CAP



HC Tester Reading	Action
0	Vehicle passed inspection; no repair is necessary. Close the recall.
1–10,000	Do the Retest Procedure below.
<p>Retest Procedure</p> <ol style="list-style-type: none"> 1. Turn the HC tester off and remove the test cap. 2. Turn on the Hydrocarbon (HC) tester by pressing and holding the power button for 3 seconds. Once powered, the tester will perform a self-check and calibration. Confirm the measurement on the screen is showing 0. Allow the tester to warm up for 30 seconds before use. 3. Clean the test cap with mild soap and water and dry with a clean cloth. 4. Retest the test cap for hydrocarbons. If the HC tester readings are above zero, a different cap should be used. 5. Reattach the test cap to the HC tester. 6. Attach the test cap to the high-pressure fuel pump solenoid. Make sure that the cutout in the test cap is aligned with the connector, then push to fully seat the cap. Leave the tester in place for 60 seconds then check the reading on the display. 	
HC Tester Retest Reading	Action
0	Vehicle passed inspection; no repair is necessary. Close the recall.
1–10,000	<ol style="list-style-type: none"> 1. Order a High-Pressure Fuel Pump Assy., Service Kit using the VIN Controlled Parts Ordering Process. 2. Continue to REPAIR PROCEDURE to replace the high-pressure fuel pump assembly. <p>NOTE: DO NOT return the vehicle to the customer until the repair procedure is completed.</p>

REPAIR PROCEDURE

⚠ WARNING

Fuel pump removal exposes fuel, which can ignite, causing a fire or explosion. This can cause serious injury or death. Always work in a well-ventilated area and keep sparks or open flames away.

- Refer to the [Fuel and Emissions Systems Service Precautions](#) before doing the procedure.
- Refer to the [Fuel Line/Quick-Connect Fitting Precautions](#) before doing the procedure.

1. Insert the emergency fuel funnel into the fuel filler neck to relieve the pressure in the fuel tank.
2. Remove the PGM-FI Main Relay 2 from the under-hood fuse box.

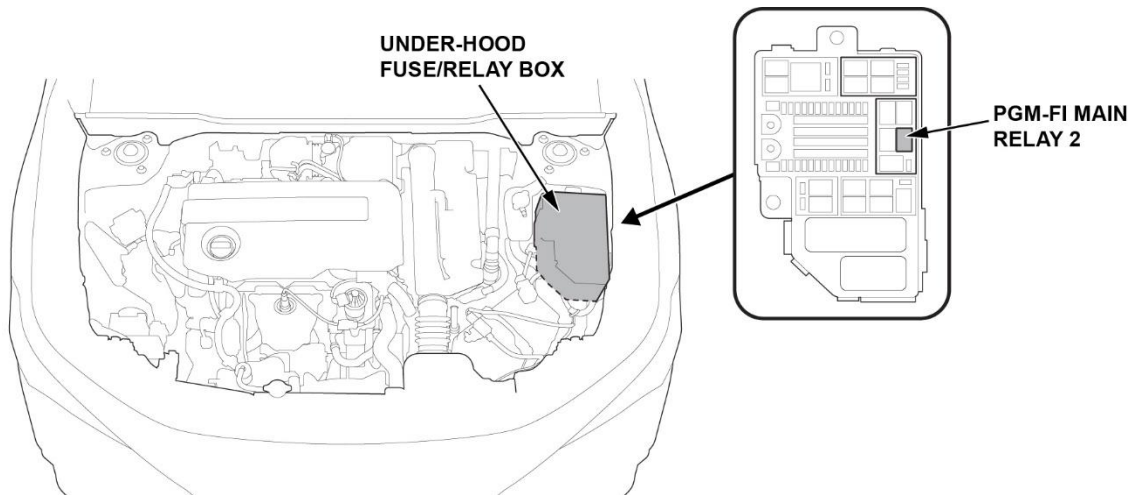

3. Enter the PGM-FI Maintenance Mode and start the engine.

1. Turn the vehicle to the OFF (LOCK) mode.

NOTE: Do the following procedure within **60 seconds** to start the engine in the maintenance mode.

2. Turn the vehicle to the ON mode without stepping on the brake pedal.

4. With the transmission in the **PARK position/mode**, press the accelerator pedal to the floor, **twice**.

5. Press the brake pedal, shift the transmission to the **NEUTRAL position/mode**, then press the accelerator pedal to the floor **twice**.

6. Press the brake pedal, shift the transmission to the **PARK position/mode**, then press the accelerator pedal to the floor **twice**.

7. Press the power switch while pressing down on the brake pedal. The vehicle is now in the maintenance mode and the engine will start.

NOTE:

- In maintenance mode the engine will start and stall approximately **4 times** until it completely runs out of fuel.
- If the engine coolant temperature gets too hot, the engine may not start until the engine coolant temperature drops.
- If the transmission fluid temperature is low, the engine speed may be limited.
- To turn the engine OFF and cancel the maintenance mode, turn the vehicle to the OFF (LOCK) mode.
- During the maintenance mode, some systems stop controls and the indicator for those systems come on.
- During cold starts in maintenance mode for about **60 seconds** there may be some additional transmission noise, this is considered normal.
- When starting the engine in maintenance mode, you may hear a groan/rattle for about the first minute, or when the engine decelerates. This noise is caused by gear tolerances, when the generator is not under load. This noise is considered normal

3. Turn the vehicle to the OFF (LOCK) mode.

4. Install the PGM-FI relay 2.

5. Disconnect the 12-volt battery.

- 2023–25 CR-V Hybrid – [12 Volt Battery Terminal Disconnection and Reconnection](#)
- 2023–24 Accord Hybrid - [12 Volt Battery Terminal Disconnection and Reconnection](#)
- 2025 Civic Hybrid - [12 Volt Battery Terminal Disconnection and Reconnection](#)

6. Remove the engine cover.

7. Loosen the engine harness holder.

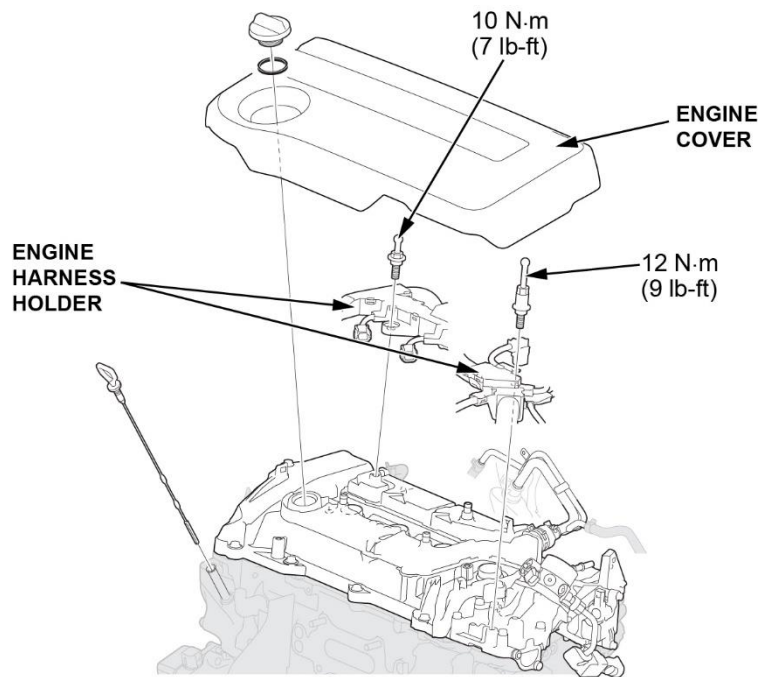

8. Remove the air cleaner.

1. Remove the resonator assembly.
2. Disconnect the fresh air hose.
3. Disconnect the mass airflow sensor.
4. Remove the air cleaner cover, housing and the air flow tube.

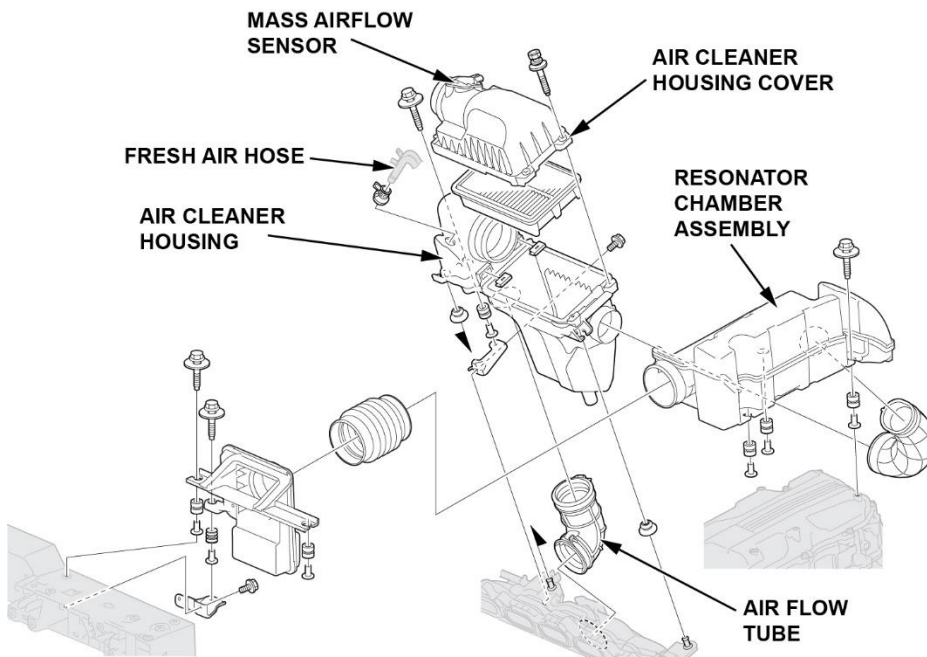

9. Remove or disconnect the following in order:
 1. Remove the quick connect fitting cover
 2. Remove the fuel feed hose cover A
 3. Disconnect fuel feed hose B from the high-pressure fuel pump
 4. Disconnect the PCV hose at the intake manifold
 5. Disconnect the intake temperature sensor connector
 6. Disconnect the MAP sensor connector
 7. Disconnect the 2 bolts holding the heater hose bracket (**Do not** remove the hoses)
 8. Disconnect the stay bracket

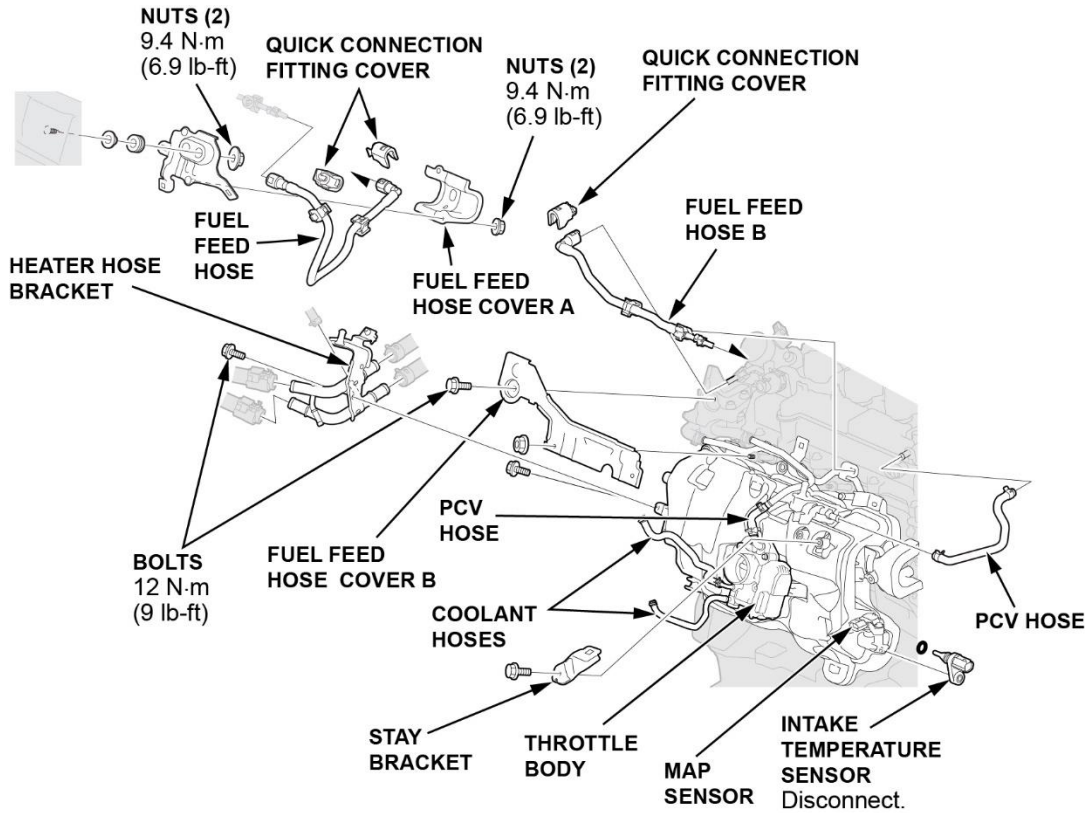

10. Remove the PCS hose at the throttle body.
 11. Remove the 4-throttle body mounting bolts.
 12. Without disconnecting the coolant hoses, move the throttle body to the side to gain clearance to remove the intake manifold.
- NOTE:** Do not excessively bend or stress the coolant hoses.

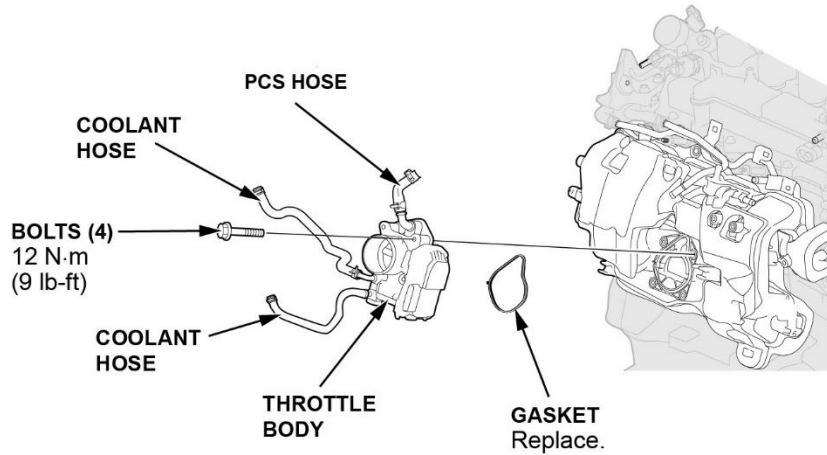

13. Remove the 4 bolts and 2 nuts securing the intake manifold.

NOTE:

- Make sure all 4 bolts and 2 nuts are removed before attempting to move the intake manifold.
- There are two different length bolts securing the intake manifold. Note the locations of the bolts while removing, to ensure they are returned to their proper location during assembly.

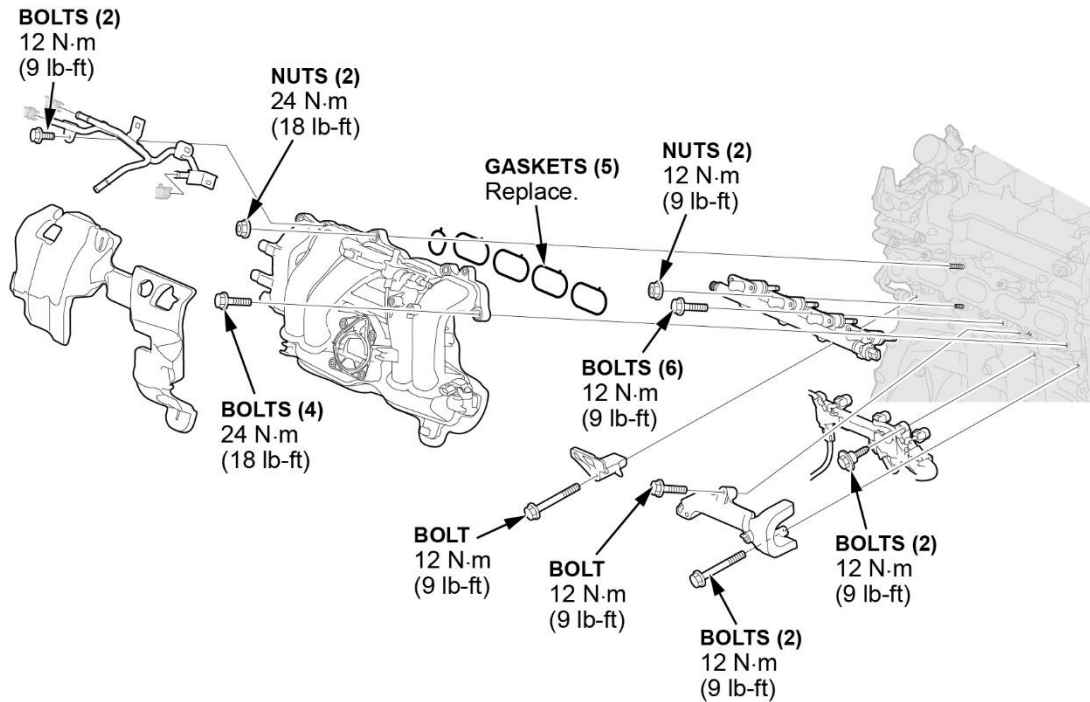

14. Remove the purge control valve and bracket.

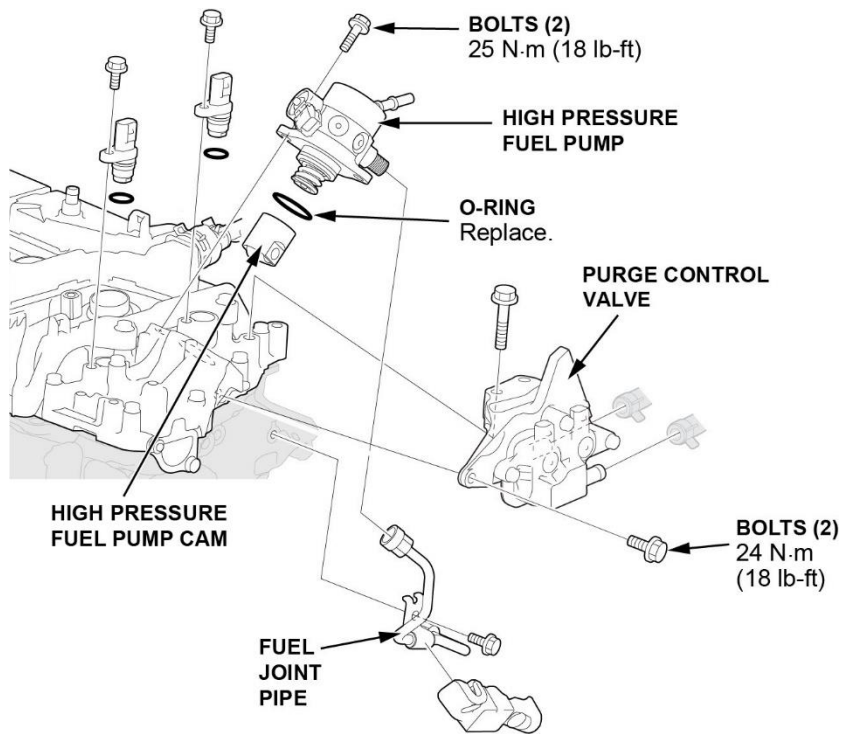

15. Remove the fuel joint pipe.

NOTE: Do not reuse the high-pressure fuel joint pipe.

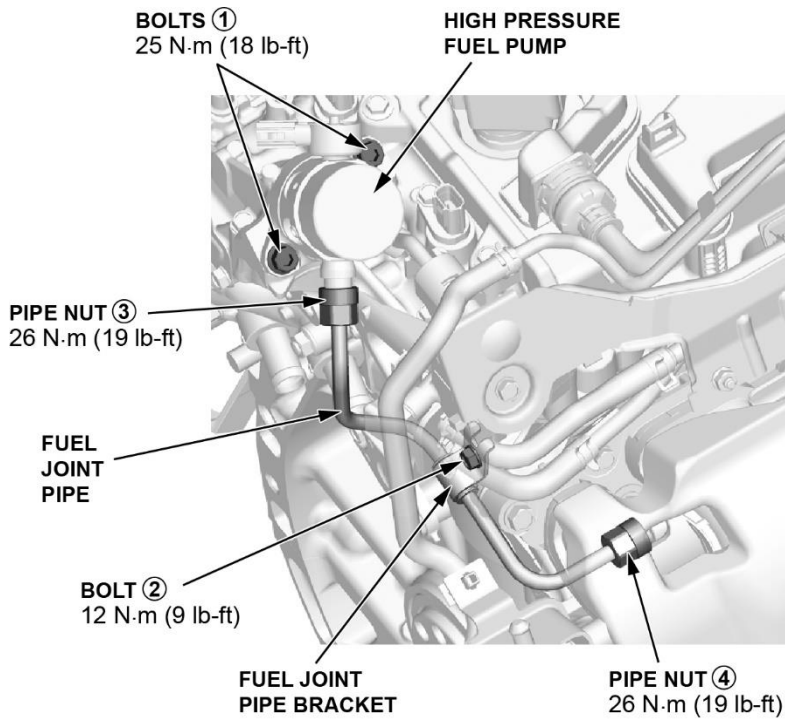

16. Remove the high-pressure fuel pump.

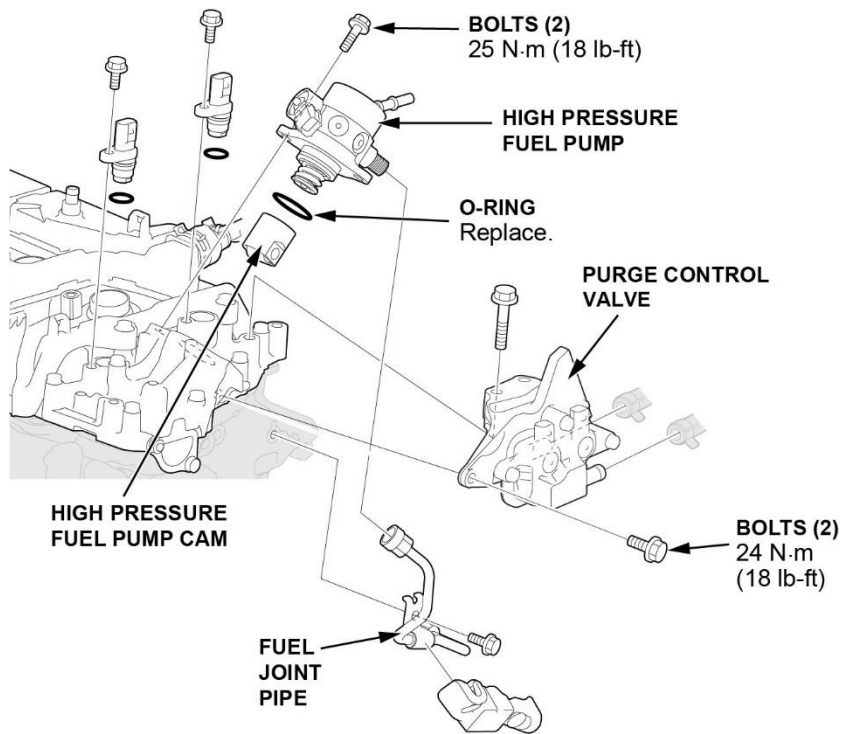

17. Install the new high pressure fuel pump and fuel joint pipe.

1. Check the position of the high-pressure fuel pump cam. If needed, rotate the crankshaft to set it to the flat position.

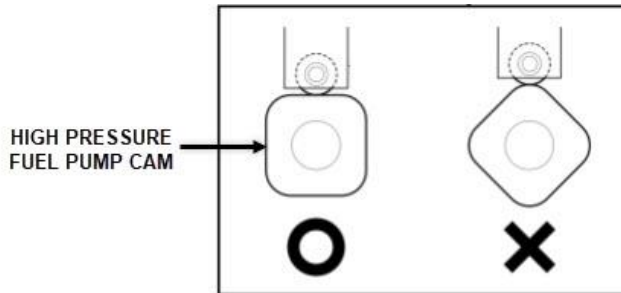

2. Lubricate the O-ring on the new high-pressure fuel pump with engine oil.
3. Tighten the high-pressure fuel pump bolts in an alternating pattern until the fuel pump is in contact with the fuel pump base.

NOTE:

- **Do not** final torque at this time.
- To prevent damage to the O-ring, **do not** use any power tools (pneumatic or electric).

4. Install the new fuel joint pipe and hand tighten the nuts and stay bolt.
5. Tighten the nuts and bolts in sequence. Torque to specification.

NOTE: When using some special tools or crowfoot-type wrenches, the torque value changes due to the added leverage. The actual torque applied will be greater than the torque reading shown.

- The torque specification given is the actual torque, not the reading on the torque wrench.
- To compensate for this additional leverage, use the formula below to calculate the torque value reading on the torque wrench.
- Always use the special tool or crowfoot-type wrench in a straight line with the torque wrench, or you will apply improper torque.

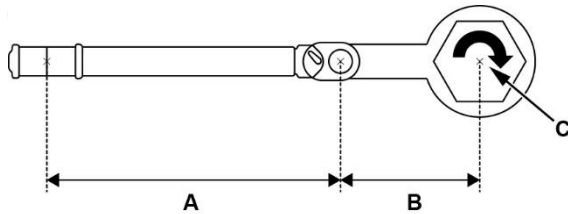

$$\text{Reading of the torque wrench} = \frac{\text{Torque wrench effective length (a)} \times \text{Specified torque (c)}}{\text{Torque wrench effective length (a)} + \text{Special tool/crowfoot type wrench effective length (b)}}$$

Step	Operation	Object	Detail
1	Hand Tighten	③, ④	The end of the joint pipe is seated on the fuel rail or high-pressure fuel pump.
2	Loosely Install	②	Install the fuel joint pipe bracket to the cylinder head, and loosely install it.
3	Tighten	All Bolts and Nuts	① → ② → ③ → ④

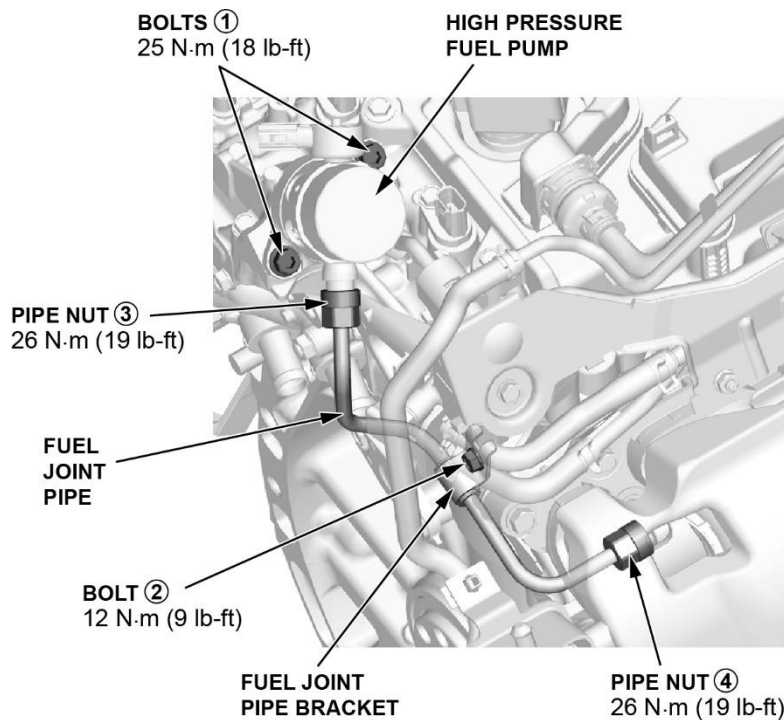

18. Apply commercially available Met-L-Check D-70 Developer to the the fuel rail and the high pressure fuel pump connections.

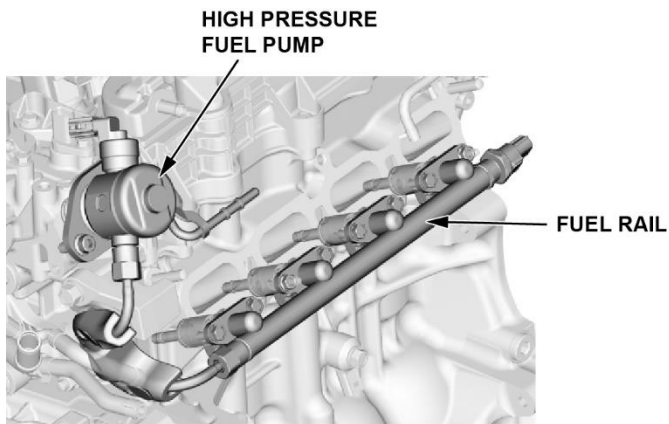

19. Install the intake manifold with new gaskets and torque to **24 N·m (18 lb-ft)**.

Tightening Procedure

Step	Operation	Object	Detail
1	Temporary Tighten	All Bolts and Nuts	Until the bolts and nuts are seated on the intake manifold
2	Temporary Tighten	All Bolts and Nuts	Until the gasket is compressed
3	Tighten	All Bolts and Nuts	①→②→③→④→⑤→⑥

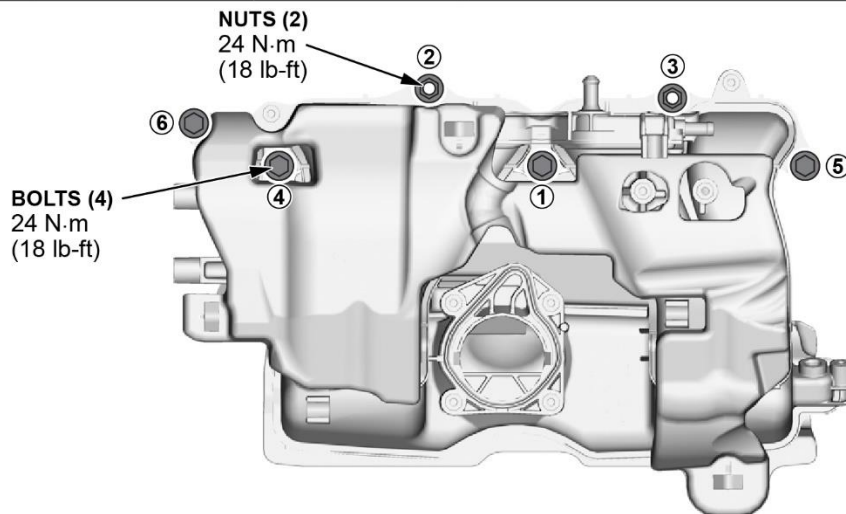

20. Install the throttle body.

Tightening Procedure

Step	Operation	Object	Detail
1	Temporary Tighten	All Bolts and Nuts	Until the bolts and nuts are seated on the intake manifold
2	Temporary Tighten	All Bolts and Nuts	Until the gasket is compressed
3	Tighten	All Bolts and Nuts	①→②→③→④

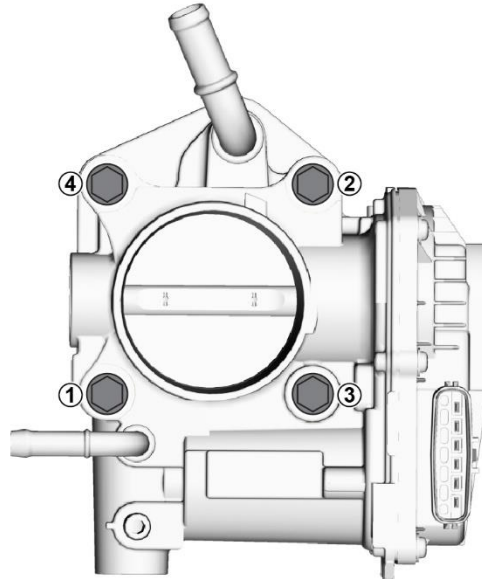

21. Install the remaining parts in the reverse order of removal.

22. Reconnect the 12-volt battery.

- 2023–25 CR-V Hybrid – [12 Volt Battery Terminal Disconnection and Reconnection](#)
- 2023–24 Accord Hybrid - [12 Volt Battery Terminal Disconnection and Reconnection](#)
- 2025 Civic Hybrid - [12 Volt Battery Terminal Disconnection and Reconnection](#)

23. Start the engine and check for fuel leaks.

- Set the probe of the HC tester on the joint pipe connections and the fuel rail. If hydrocarbons are detected, repair the leak and retest.

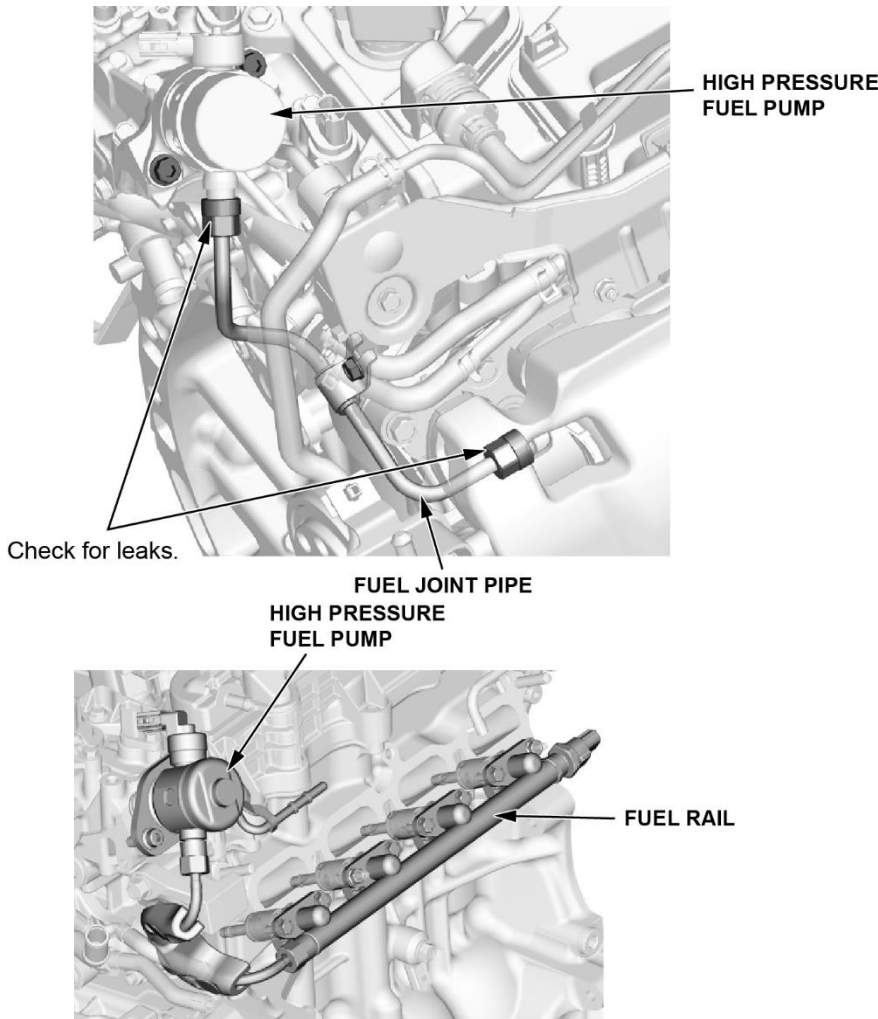

24. Do the [Steering Angle Neutral Position Learning](#).

25. Do an All DTC clear.

26. *California residents only:* Fill out a Vehicle Emissions Recall – Proof of Correction certificate and use **QK8** as the recall number. Have the service advisor give the certificate to your customer and advise him or her to keep it as proof that the recall was completed. Your customer will need to submit this certificate to the DMV only if the DMV requests it. If you need more certificates, use reorder number **Y0657**.

Vehicle Emission Recall - Proof of Correction				
License Number	Make	Year Model	Body Type	Vehicle Identification Number
Manufacturer			Recall Number QK8	
The above described vehicle has been repaired, modified and/or equipped with emission control devices to meet applicable California Emission Control Laws.				
Dealer's Name		Address, City, State and Zip		
Date	Dealership's Authorized Signature			
	X			
Return this certificate to DMV only when required - otherwise retain for your records.				
Y0657		ACL 24832 (0212)		