



**NHTSA Recall No. 24V-934
Cummins Campaign #C5807
2nd Notice**

November 3, 2025



Generator sets eligible for Cummins Campaign # C5807:

Generator Serial Number	Generator Model	Vehicle Identification Number
K230293520	C275D2RE	5851f1530pp02 [REDACTED]
L230295678	C275D2RE	5851f1530pp02 [REDACTED]

Cummins Inc.
Box 3005
Columbus, IN 47202-3005 USA
Mail Code: 40911
Phone 1 800 CUMMINS
care.cummins.com



NHTSA Recall No. 24V-934
Cummins Campaign #C5807
2nd Notice

IMPORTANT SAFETY RECALL

This notice applies to your Cummins Power Generation C275D2RE Generator Sets listed in the table on the enclosed generator set list.

November 3, 2025

Dear Cummins Customer:

This notice is sent to you in accordance with the National Traffic and Motor Vehicle Safety Act.

Cummins Inc. has decided that a defect which relates to motor vehicle safety exists in certain trailer-mounted C275D2RE Generator Sets that were manufactured between February 9, 2022 and September 13, 2024.

WHY IS A RECALL BEING CONDUCTED?

Exposed leads providing service access to fuse holders within the wiring harness of the subject generator sets may vibrate and chafe against the housing or terminal stud of the starter motor, abrading the wire insulation. This condition may result in an electrical short. An electrical short in the generator set wiring harness creates a risk of electric shock and/or fire which in turn presents a risk of burns or smoke inhalation.

WHAT ARE WE DOING ABOUT THE PROBLEM?

Cummins has released field Safety Campaign 'Safety Campaign #5807 C275D2RE Generator Set Harness Inspection and Repair' to correct this condition by (i) inspecting the generator set wiring harness for signs of chafing and abrasion, (ii) repairing or replacing the generator set wiring harness if it is found to be damaged, and (iii) securing the exposed wiring harness leads to prevent contact with the housing or terminal stud of the starter motor. Repair parts are currently available at Cummins Distributors and authorized warranty repair locations. The repair will be completed free of charge. In cases where inspection of the generator set wiring harness does not reveal signs of chafing or abrasion damage, securing the exposed wiring harness leads will require approximately 0.5 hours to complete. In cases where replacement of the generator set wiring harness is necessary, the repair will require approximately 3.5 hours to complete.

WHAT SHOULD YOU DO?

Until the campaign is completed, operators are advised to inspect the generator set each day before use. If the exposed wiring harness leads are found to be touching the housing or terminal stud of the starter motor or show signs of chafing or damage, operators are advised to stop using the generator and contact a Cummins distributor or authorized warranty repair location for assistance. Instructions for performing this daily inspection, including examples of exposed wiring harness leads touching the housing and terminal stud of the starter motor, are included as a supplement to this owner notification letter in Appendix A.



NHTSA Recall No. 24V-934
Cummins Campaign #C5807
2nd Notice

Contact the nearest Cummins Distributor or authorized warranty repair location to arrange to have this campaign performed on your generator set. The distributor or authorized repair location will work with you to schedule the best date to complete this repair.

Federal law requires lessors receiving this recall notice to forward a copy of this notice to the lessee within ten (10) days. Also, it is a violation of Federal law for a dealer to deliver generator sets covered by this recall notice under a sale or lease until the defect has been remedied.

To find a service provider near you, please use the Service Locator tool found at the Cummins sponsored website <https://quickservice.cummins.com>.

WHO SHOULD YOU CONTACT IF YOU HAVE FURTHER QUESTIONS OR CONCERNS?

If you have questions or concerns about this recall, please contact your local Cummins Distributor or authorized warranty dealer. You may also contact Cummins Care at 1-800-CUMMINS (1-800-286-6467) or visit our website at <https://care.cummins.com>.

If you have a complaint relative to this recall, you may report it to the following:

Administrator
National Highway Traffic Safety Administration
1200 New Jersey Avenue, SE
Washington, DC 20590

You may also call the toll-free Vehicle Safety Hotline at 1-888-327-4236 (TTY: 1-800-424-9153); or go to <http://www.safercar.gov>.

In order to serve you better it is important to register your product. If you have not already registered your Cummins product, or your details need to be updated, use one of the following options to register your product. Using your phone or tablet, scan the QR Code below and complete the registration online. Or, using your laptop, you can register your product at <https://prodreg.cummins.com>.

If you are no longer the owner of the generator set(s) listed in the enclosed table, please forward this notice to the new owner or provide the new owner's contact information via email to Cummins at cummins.campaign.administration@cummins.com so that we can update the contact information and notify them of this recall.

Finally, if the generator set has been scrapped, or otherwise taken out of service, and replaced with another Cummins product, please contact your local Cummins Distributor or authorized repair location for assistance in handling the necessary updates for your Cummins product.

Cummins is taking this action in the interest of safety and satisfaction with our products. We apologize for any inconvenience and thank you for your attention to this matter.

Sincerely,

Campaign Administrator

Cummins Inc.
Box 3005
Columbus, IN 47202-3005 USA
Mail Code: 40911
Phone: 1 800 CUMMINS
care.cummins.com



NHTSA Recall No. 24V-934
Cummins Campaign #C5807
2nd Notice

Cummins Inc.

Scan the QR code and complete the registration of your Cummins product online.



Appendix A – Instructions for Inspecting the Generator Set Wiring Harness

1. De-energize and lockout/tagout the generator set as described in the Cummins Power Generation Generator Set Owner's Manual supplied with the unit.
2. Open the service door on the left side of the unit (non-control side)
3. Locate the engine's starter motor and inspect the nearby red wires with fuse holders outside of the protective loom for signs of chafing or damage. The inspection location is illustrated in Figure 1.
4. If the red wires are touching the housing or terminal stud of the starter motor, or if the red wires show signs of chafing or damage, DO NOT use the unit until repaired by a certified Cummins repair facility. An example of the exposed red wires touching the terminal stud of the starter motor, and the resulting chafing damage to the wire insulation, is shown in Figure 2. An example of the exposed red wires touching the housing of the starter motor is shown in Figure 3.

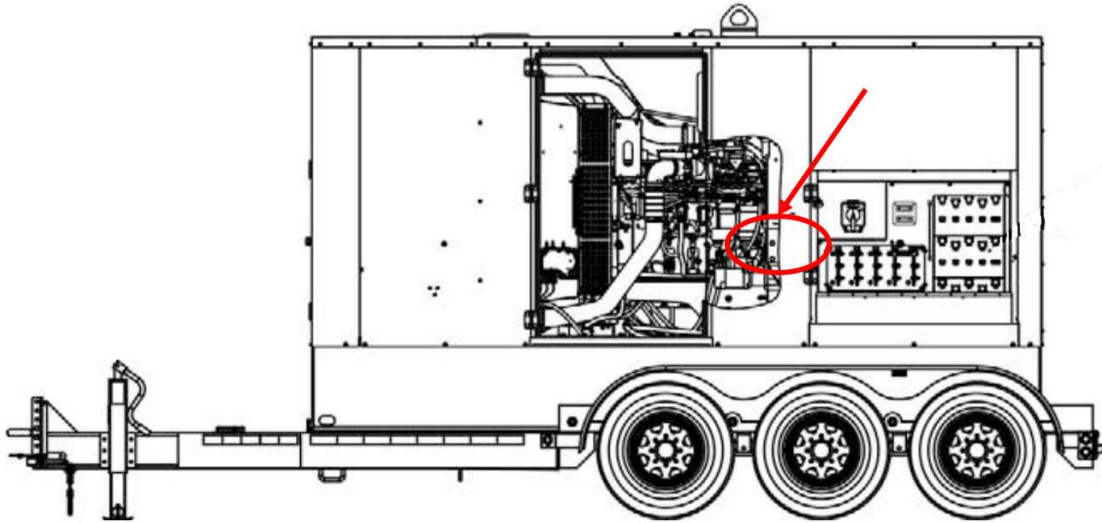

Figure 1: Inspection Location on Generator Set

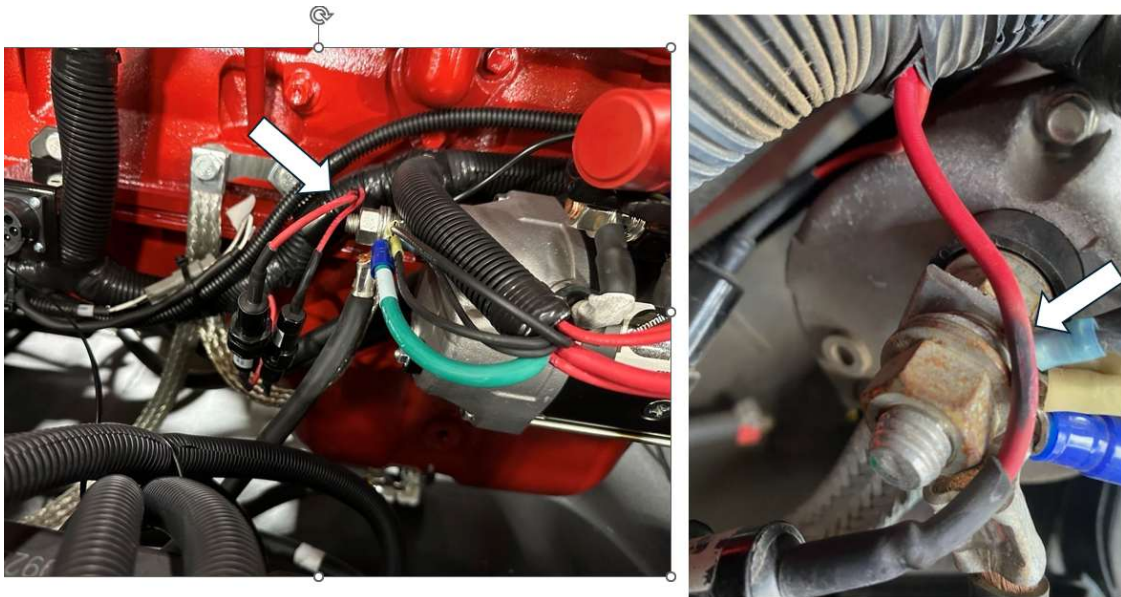

Figure 2: Example of exposed red wires touching the terminal stud of the starter motor, and resulting chafing damage