



TEREX®

December 11, 2024

'owner'

'address1'

'city', 'state' 'zip'

IMPORTANT SAFETY RECALL

NHTSA Recall No. 24V-526

This notice applies to your vehicle

Dear Terex Equipment Owner,

This notice is sent to you in accordance with the National Traffic and Motor Vehicle Safety Act.

REASON FOR NOTICE

Terex South Dakota, Inc. has decided that a defect, which relates to motor vehicle safety, exists in certain 2014-2020 XT Pro model aerial devices manufactured prior to August 2020, that were equipped with the new style replacement basket brackets purchased from November 19, 2020 through June 10, 2024.

The new style replacement basket brackets as noted above may not be compatible with the original basket retaining pins on models manufactured prior to August 2020. If both basket retaining pins disengage, the basket may tilt which can cause personal injury to the occupants of the basket.

WHAT TEREX WILL DO

Terex will provide Field Service Kit Z1724, parts and labor, at no cost to the purchaser of the replacement brackets. The Field Service Kit Z1724 provides basket retaining pins and hardware to replace the original basket retaining pins. The remedy will take approximately one (1) hour to complete.

Locate your nearest Terex Utilities Service Center by visiting our website at www.terexutilities.com and select the Service tab. To schedule repairs with Terex Utilities Field Service, call 1-844-837-3948. The Terex Utilities Warranty Department can also be reached at 1-844-837-3948 or by email at utilities.warranty@terex.com. Repairs can also be coordinated through our Dealer Service network as noted on the map included with this mailing.

WHAT THE OWNER MUST DO

1. Immediately inform all users, operators, and supervisors of the contents of the bulletin.
2. Before the next use of the aerial device, inspect for compatibility of the basket bracket and the basket retaining pins the figures in the bulletin as reference. Each basket retaining pin must extend through the basket bracket tube and the pin must have a method of retainment when the pin is fully installed such as retaining balls or secondary locking pins.

CONTINUED USE

1. If the basket bracket and basket retaining pins are not compatible, do not use the aerial device until the machine is corrected.
2. If the basket bracket and basket retaining pins are compatible, complete and return the completion form; no further action is required.
3. Always follow all operation, inspection, and maintenance requirements as specified in the manuals.

Terex South Dakota, Inc.
3140 15th Ave SE
Watertown, SD 57201 USA
1-844-837-3948 • Fax 1-605-882-1842

If you have any questions you can find your nearest dealer at this web site:
<http://www.terex.com/utilities/en/products/dealer-locator/index.htm>.

If you take your unit to your dealer on the agreed service date and they do not remedy this condition on that date or within three (3) working days of scheduled appointment, we recommend you contact Terex Utilities Warranty department by calling 1-844-837-3948.

Note to Owners: If the manufacturer or their dealer has failed or is unable to remedy the defect/noncompliance condition without charge or within a reasonable amount of time you can notify:

Administrator
National Highway Traffic Safety Administration
1200 New Jersey Avenue, SE, West Building,
Washington, DC 20590

Or call the toll-free DOT auto Safety Hotline at 1-888-327-4236 (TTY: 1-800-424-9153; or go to <http://www.safercar.gov>.)

If you have had your unit repaired for this issue prior to receipt of this notice, you may be eligible for reimbursement. For more information, please contact Terex Utilities at the above contact information.

If you have sold or retired the unit please let us know by contacting the Terex Utilities Warranty department at 1-844-837-3948 or send the serial number and new owner contact information to utilities.warranty@terex.com . Forward this Notice and any other uncompleted bulletins to the new owner within 10 days of receipt of this letter.

If you have leased this vehicle to another person, forward a copy of this notice to the lessee within ten days of your receipt of this notice.

Thank you for your immediate attention on this important matter,

Rory Lindner
Warranty Manager

Our records indicate the following machines, registered to you, are involved in SN729.

Serial Number	Terex Order Number	Customer Purchase Order Number
'Serial number'	'Order'	'PO number'



Terex Utilities

SAFETY NOTICE

SN729

DATE: 7/18/2024

REVISED:

TO: Owners, Users, Dealers, and Installers

MODELS AFFECTED: XT Pro Aerial Device

SUBJECT: Replacement Basket Bracket

Issue:

Terex South Dakota, Inc. has identified a potential defect relating to motor vehicle and operational safety may exist in XT Pro model aerial devices manufactured prior to August 2020 when equipped with the new style replacement basket brackets purchased from November 19, 2020 through June 10, 2024.

The new style replacement basket brackets as noted above may not be compatible with the original basket retaining pins on models manufactured prior to August 2020. **If both basket retaining pins disengage, the basket may tilt which can cause personal injury to the occupants of the basket.**

Action:

What the Owner Must Do:

1. Immediately inform all users, operators, and supervisors of the contents of this bulletin.
2. Before the next use of the aerial device, inspect for compatibility of the basket bracket and the basket retaining pins using Figures 1 through 4 at the end of this bulletin as reference. Each basket retaining pin must extend through the basket bracket tube and the pin must have a method of retainment when the pin is fully installed such as retaining balls or secondary locking pins.

Continued Use:

1. If the basket bracket and basket retaining pins are not compatible, do not use the aerial device until the machine is corrected.
2. If the basket bracket and basket retaining pins are compatible, complete and return the completion form; no further action is required.
3. Always follow all operation, inspection, and maintenance requirements as specified in the manuals.

What Terex will Do:

Terex will provide Field Service Kit Z1724, parts and labor, at no cost to the purchaser of the replacement brackets. The Field Service Kit Z1724 provides basket retaining pins and hardware to replace the original basket retaining pins. The remedy will take approximately one (1) hour to complete.

Locate your nearest Terex Utilities Service Center by visiting our website at www.terexutilities.com and select the Service tab. To schedule repairs with Terex Utilities Field Service, call 1-844-837-3948. The Terex Utilities Warranty Department can also be reached at 1-844-837-3948 or by email at

Terex South Dakota, Inc.
3140 15th Ave SE
Watertown, SD 57201 USA
1-844-837-3948 • Fax 1-605-882-1842

utilities.warranty@terex.com. Repairs can also be coordinated through our Dealer Service network as noted on the map included with this mailing.

If you have sold the unit involved in this bulletin forward this bulletin to the new owner within 10 days and notify Terex of the serial number and contact information for the new owner.

Dealers, Owners, and Installers: A letter is being sent to all purchasers of affected brackets. Dealers, if machines with affected brackets are in your area, the customer may contact you to arrange the repairs. Labor allowance is \$150 per machine to replace the basket retaining pins and retaining hardware.

Only XT Pro models that had the basket bracket replaced during the timeframe listed in this bulletin are involved. Dealers, if the owner contacts you call Terex Utilities Warranty Department at 1-844-837-3948 for instructions.

Parts orders of affected brackets, as shown on the owner letter, will have the repairs performed at no charge to the owner. It will take approximately one (1) hour to complete the repair.

Important: Some of the involved units may be in rental fleets. Federal Law requires you to complete the recall service on these units before renting, or to inform the renters within 10 days of receipt of this bulletin.

Note to Owners: If the manufacturer or their dealer has failed or is unable to remedy the defect/noncompliance condition without charge or within a reasonable amount of time you can notify:

Administrator
National Highway Traffic Safety Administration
1200 New Jersey Avenue, SE, West Building
Washington, DC 20590

Or call the toll-free DOT auto Safety Hotline at 1-888-327-4236 (TTY: 1-800-424-9153; or go to <http://www.safercar.gov> .)

Terex and local industry standards (CSA and ANSI) require the purchaser of a Terex unit report to Terex the model and serial number of each machine sold, as well as the name, address, and telephone number of the new owner, within 60 days of the sale. Use the Owner Update Form in the manual to update the owner status of any of your machines. Terex also asks the seller to provide the new owner information so if you require additional copies of the Owner Update Form or have any questions, please contact Terex Utilities Warranty Department at 1-844-837-3948 or utilities.warranty@terex.com.

Terex, OSHA and local industry standards, also require that the manufacturer's bulletins be completed. It is your responsibility to communicate this important information to all machine owners and applicable branches. If you require additional copies of this bulletin or have any questions, please contact Terex Utilities at 1-844-837-3948.

To register your Terex Utilities aerial device or digger derrick, click or navigate to the following link: <https://www.terex.com/utilities/en/support/product-registration>

Reference Figures

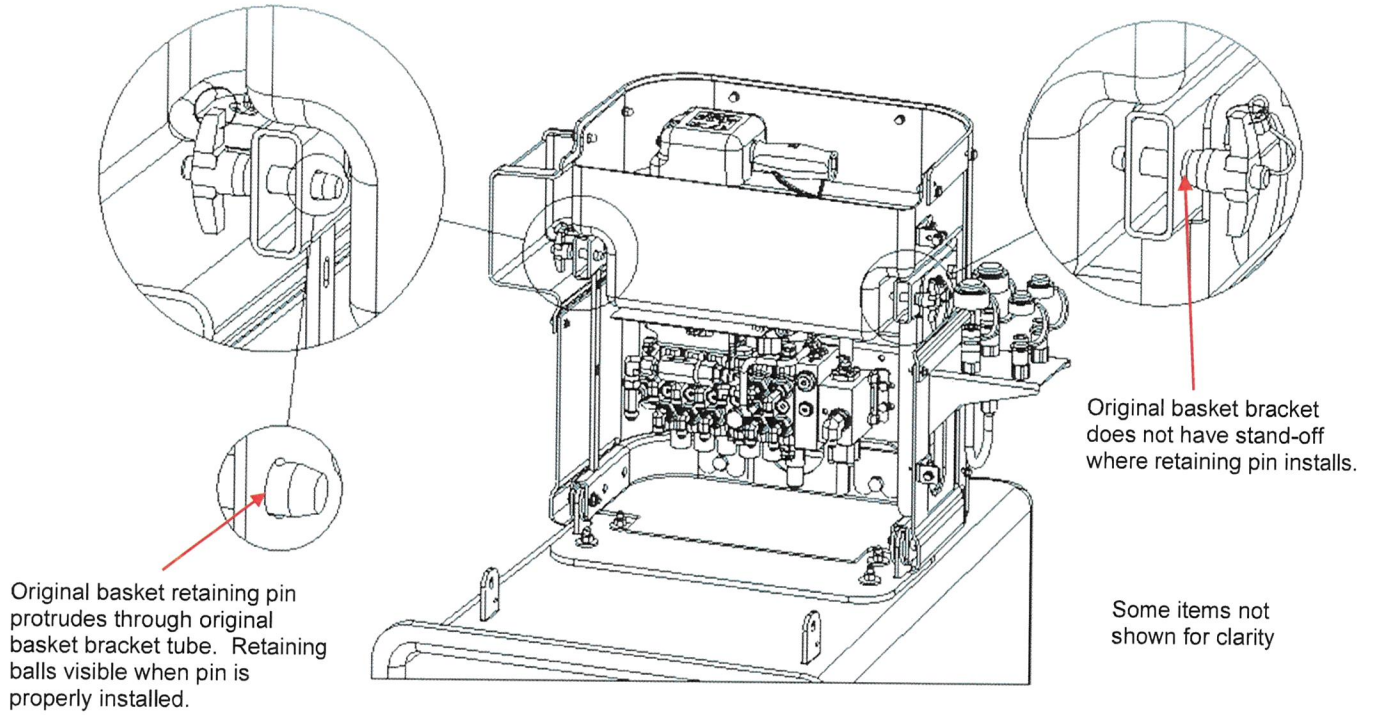

Figure 1. Compatible Components - Original basket bracket and original basket bracket retaining pins
In production from 7/21/2014 through 7/30/2020

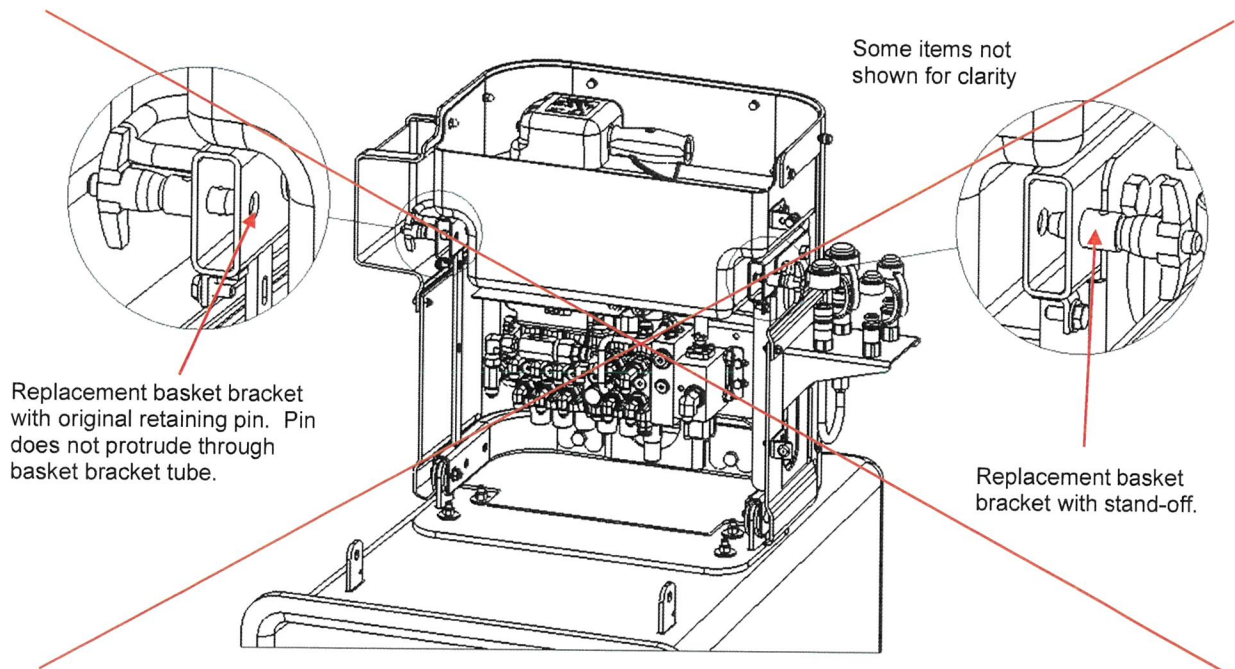

Figure 2. Incompatible Components - Replacement basket bracket and original basket bracket retaining pins

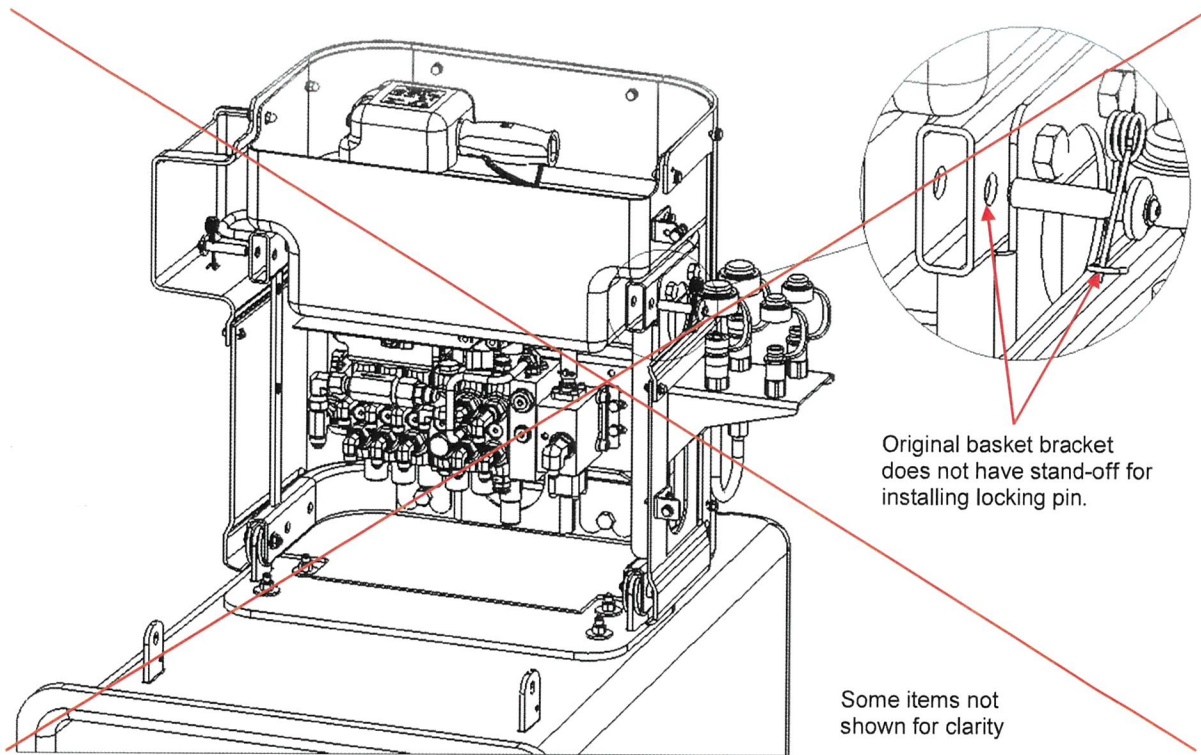

Figure 3. Incompatible Components - Original basket bracket and incompatible basket bracket retaining pins

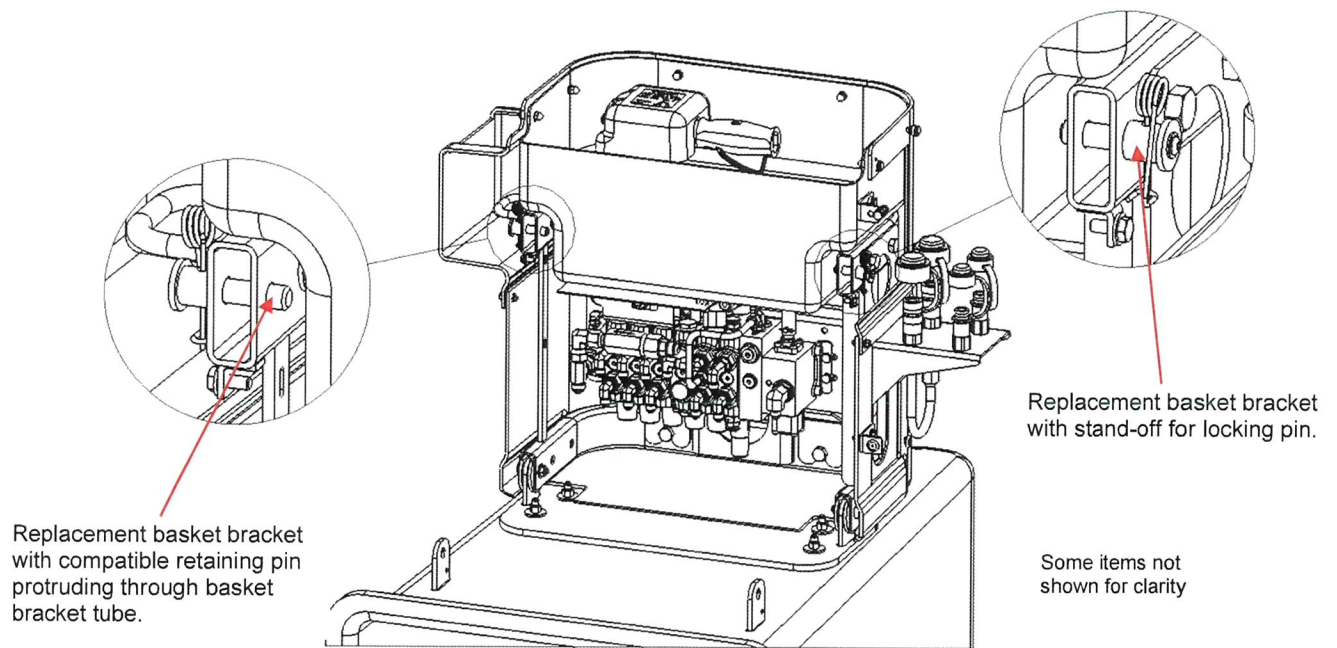

Figure 4. Compatible Components - Replacement basket bracket and compatible basket bracket retaining pins
In production from 4/22/2020 through present day



TEREX

Utilities

Safety Notice 729

Completion Form

XTPro Aerial Device Replacement Basket Bracket, Basket Retaining Hardware

TO AVOID DELAYS IN PROCESSING – PLEASE PRINT LEGIBLY

UNIT INFORMATION (*REQUIRED)

CHECK if new owner

Customer Truck # _____

*Owner Name: _____

Owner Phone Number: _____

*Address req'd if new owner _____

*Truck VIN # _____

*Unit Serial Number: _____ (10 digits)

*Ref original Sales Order# or Purchase Order# _____

SERVICE PERFORMED BY (*REQUIRED)

* Date of Repair or Inspection _____

* Service Technician (ST) completing work: _____

* ST Company Name: _____ ST Location: _____

ST Contact Number: _____

*** CHECK TO VERIFY COMPLETION:**

I have inspected the basket bracket weldment mounted on the above noted unit, per the SN729 bulletin, and determined that **the correct basket retaining pins & hardware are already in use on this machine.** (See SN729 bulletin for examples).
No labor allowance for the inspection.

The basket bracket basket retaining pins & hardware **have been replaced using the Z1724 Field Service Kit** on the above noted unit. Contact the Terex Utilities Warranty Department at 1-844-837-3948 or email utilities.warranty@terex.com with any questions.

*If you are unsure if the basket bracket/basket retaining pin combination on your machine is affected by this safety notice, please contact us at 1-844-837-3948 or send an email with a picture to utilities.warranty@terex.com.

NOTE: Maximum labor allowance is \$150.00 per unit, which is compensable to party performing update. No labor allowance for only inspecting a unit. There is no travel allowance for units in rental fleets. Travel allowance of up to \$600.00 is compensable for customer owned units. Travel greater than \$600.00 requires pre-approval by the Terex Warranty Department by emailing utilities.warranty@terex.com

Work Order: _____

Comments: _____

RETURN THIS COMPLETED FORM TO THE TEREX UTILITIES WARRANTY DEPT. VIA EMAIL TO utilities.warranty@terex.com

Terex Utilities Service Network

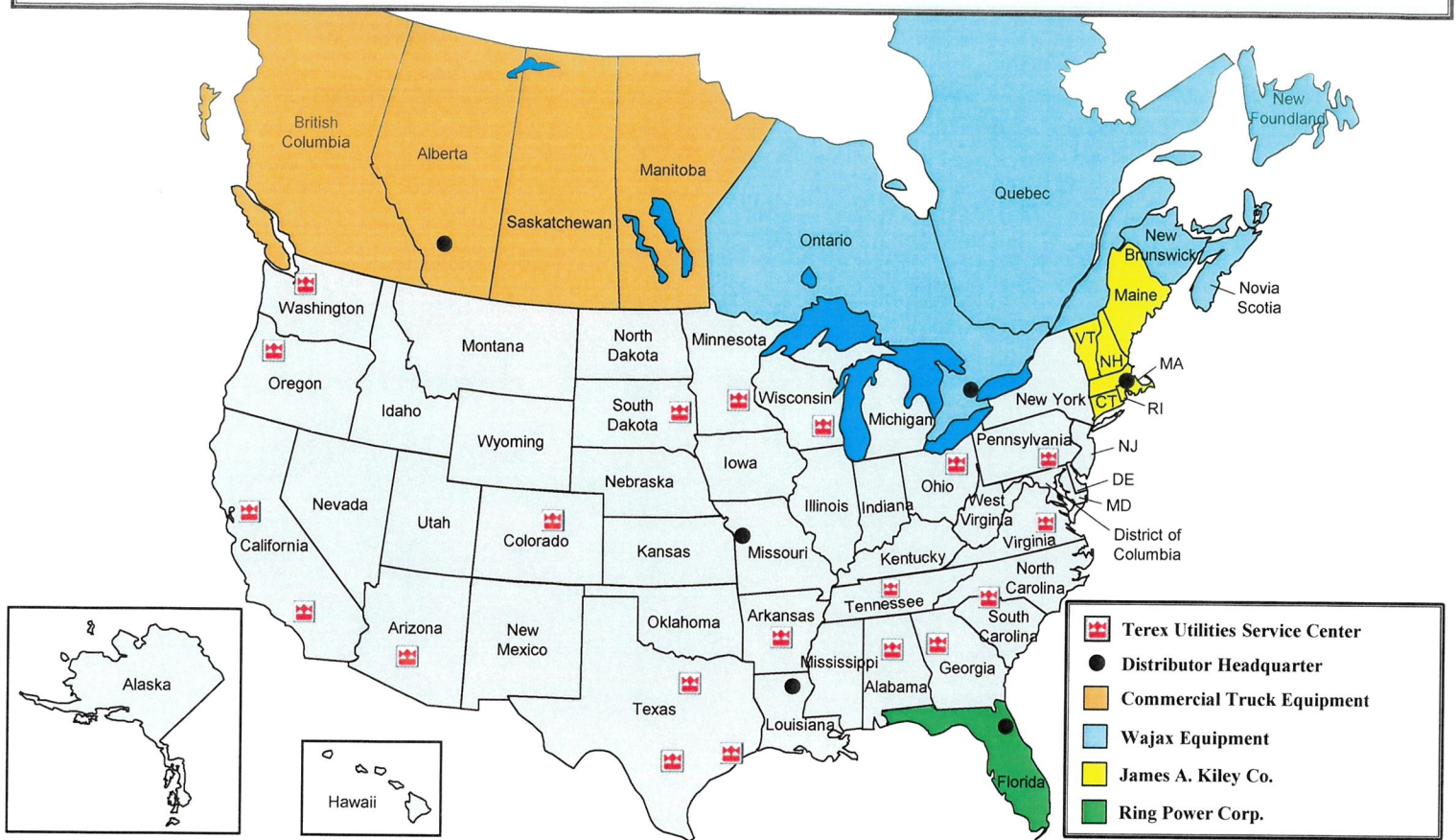



- Terex Utilities Service Center
- Distributor Headquarter
- Commercial Truck Equipment
- Wajax Equipment
- James A. Kiley Co.
- Ring Power Corp.



Terex Utilities		
Seattle 206.764.5025	Houston 346.261.3200	Medina 330.722.6900
7829 South 2016 th Street Kent, WA 98032	6610 Thompson Rd Baytown, TX 77521	1175 Industrial Parkway Medina, OH 44256
Portland 503.620.0611	N. Little Rock 501.945.6100	Waukesha 262.547.8500
12805 SW 77 th Place Tigard, OR 97223	309 Dixie Street North Little Rock, AR 72114	N4W22610 Bluemound Rd Waukesha, WI 53186
Stockton 209.242.7104	Birmingham 205.841.6411	Shakopee 952.445.1555
2610 Lycoming Street Stockton, CA 95206	4120 Lewisburg Rd Birmingham, AL 35207	12565 Hwy 41 Frontage Rd Shakopee, MN 55379
Fontana 909.565.1234	White House 615.672.4911	Watertown 605.882.3004
8594 Cherry Avenue Fontana, CA 92335	200 Edenway Dr White House, TN 37189	1901 14 th Avenue NW Watertown, SD 57201
Phoenix 602.256.0162	Charlotte 704.654.3903	Denver 303.202.0304
4920 W. Magnolia Street Phoenix, AZ 85043	11945 Goodrich Drive Charlotte, NC 28273	6295 E. 56 th Avenue Commerce City, CO 80022
Fort Worth 817.698.8005	Glen Allen 804.752.2811	Atlanta 470.291.1133
3155 S. Burlison Blvd. Burlison, TX 76028	11072 Washington Hwy Glen Allen, VA 23059	1400 Oakley Industrial Blvd Fairburn, GA 30213
San Antonio 210.476.7777	Lancaster 717.650.1044	Field Service 800.292.1931
142 Gemblar Rd San Antonio, TX 78219	180 N. Donnerville Rd, Suite B Mountville, PA 17554	

Distributors
Commercial Truck 877.915.9140
11199 48 St SE Calgary, AB T2C 5H4, Canada
Wajax Equipment 519.893.2942
2250 Argentia Rd Mississauga, ON L5N 6A5, Canada
James A. Kiley Co. 617.776.0344
15 Linwood Street Somerville, MA 02143-2188
Ring Power Co. 904.737.7730
500 World Commerce Pkwy St. Augustine, FL 32092
Scott Powerline 877.388.9269
3018 Harvester Drive Monroe, LA 71201
Custom Truck 833.281.7911
7701 Independence Ave Kansas City, MO 64125

Sample of window envelope, address shows through window.

 TEREX <i>Utilities</i> 3140 15 th Ave SE Watertown, SD 57201-9017	IMPORTANT SAFETY RECALL INFORMATION		
 U.S. Department of Transportation	Issued in Accordance With Federal Law	 NHTSA <small>www.nhtsa.gov</small>	
SAFETY RECALL NOTICE			
<table border="1"><tr><td>“Customer’s Name” “Address” “City”, “State” “Zip Code”</td></tr></table>			“Customer’s Name” “Address” “City”, “State” “Zip Code”
“Customer’s Name” “Address” “City”, “State” “Zip Code”			

Alternate format: Normal envelope, with address label or printed envelope.

 TEREX <i>Utilities</i> 3140 15 th Ave SE Watertown, SD 57201-9017	IMPORTANT SAFETY RECALL INFORMATION	
 U.S. Department of Transportation	Issued in Accordance With Federal Law	 NHTSA <small>www.nhtsa.gov</small>
SAFETY RECALL NOTICE “Customer’s Name” “Address” “City”, “State” “Zip Code”		