



TEREX®

Terex Utilities

SAFETY NOTICE

SN728

DATE: 7/24/2024

REVISED:

TO: Owners, Users, Dealers, and Installers

MODELS AFFECTED: TM Aerial Devices

SUBJECT: Platform Tilt Controller

Issue:

Terex South Dakota, Inc. has identified a potential defect relating to motor vehicle and operational safety may exist in TM model aerial devices, produced from June 16, 2022 through October 13, 2023. If electrical power is lost to the level sensor for the platform tilt controller, the platform may tilt in an uncontrolled manner while squeezing the unit control enable trigger. **Tilting of the platform may cause the platform occupants to fall resulting in injury.**

Action:

What the Owner Must Do:

1. Immediately inform all users, operators, and supervisors of the contents of this bulletin.
2. Deploy the outriggers and position the booms in the ground mount position clear of any obstacles; position with lower boom fully articulated and the upper boom articulated and extended so the basket is 6 inches to 12 inches above the ground.
3. Remove needed covers to verify that the power wire for the Level Sensor is securely connected to the sensor, is undamaged along its length, and routed so it cannot be pinched, see Figures 1 through 3 at the end of this bulletin as reference. Repair, replace, or re-route the power wire as required.
4. Standing on the ground beside the basket and clear of the path of motion of the basket, squeeze the upper control enable trigger.
 - a. If the basket begins tilting downward, release the enable trigger. Do not use the machine until corrected.
 - b. If the basket does not tilt while only squeezing the enable trigger, see the Continued Use section of this bulletin.
5. After verifying the integrity of the power wire, re-install any removed covers. The unit can be used following the instructions in the Continued Use section below as well as all operator, maintenance, and inspection requirements as specified in the manuals.

Continued Use:

1. Inform the users of the content of this bulletin and remind them of the daily pre-shift inspection requirements.
2. Inform the users that personal fall protection equipment is required to be used whenever occupying the platform of an aerial device.
3. Repeat the checks from Steps 2 & 4 of the Action section above daily before the first use of the aerial device from the platform.

4. Inform the users that tilting of the platform due to the lost electrical signal to the level sensor will only occur when the single stick enable trigger is squeezed. **Releasing the enable trigger will stop the platform tilting.**
5. If the leveling system malfunctions, utilize the following procedure to correct the leveling system and stow the boom:
 - a. From the lower controls shut off the upper controls by rotating the "Top Control and Option Shut-Off" to the "OFF" position.
 - b. Use the lower controls to level platform and stow boom. With the "Top Control and Option Shut-Off" rotated to the "OFF" position, the platform will not level while operating the boom from the lower controls. Stop stowing operations as needed to level the platform using the level control.
 - c. Do not use the machine until the malfunction is repaired or the controller is replaced.
6. Always follow inspection and maintenance requirements as specified in the manuals.

What Terex will Do:

Terex will provide Field Service Kit Z1723, parts and labor, at no cost to the customer. The Field Service Kit Z1723 provides a replacement platform tilt controller. It will take approximately two (2) hours to remove the existing controller, install the replacement controller, and to test the machine.

Locate your nearest Terex Utilities Service Center by visiting our website at www.terexutilities.com and select the Service tab. To schedule repairs with Terex Utilities Field Service, call 1-844-837-3948. The Terex Utilities Warranty Department can also be reached at 1-844-837-3948 or by email at utilities.warranty@terex.com. Repairs can also be coordinated through our Dealer Service network as noted on the map included with this mailing.

If you have sold the unit involved in this bulletin forward this bulletin to the new owner within 10 days and notify Terex of the serial number and contact information for the new owner.

Dealers and Installers: A letter is being sent to owners of affected units. If affected units are in your area, the customer may contact you to arrange the repairs. Labor allowance is \$300 per machine to replace the platform tilt controller and test the machine.

Only TM model aerial devices produced in the timeframe listed in this bulletin are involved. If the owner contacts you call Terex Utilities Warranty Department at 1-844-837-3948 for instructions and to arrange shipment of parts.

Affected units, as shown on the owner letter, will have the repairs performed at no charge to the owner. It will take approximately two (2) hours to complete the repair.

Important: Some of the involved units may be in rental fleets. Federal Law requires you to complete the recall service on these units before renting, or to inform the renters within 10 days of receipt of this bulletin.

Note to Owners: If the manufacturer or their dealer has failed or is unable to remedy the defect/noncompliance condition without charge or within a reasonable amount of time you can notify:

Administrator
National Highway Traffic Safety Administration
1200 New Jersey Avenue, SE, West Building
Washington, DC 20590

Or call the toll-free DOT auto Safety Hotline at 1-888-327-4236 (TTY: 1-800-424-9153; or go to <http://www.safercar.gov> .)

Terex and local industry standards (CSA and ANSI) require the purchaser of a Terex unit report to Terex the model and serial number of each machine. Use the Owner Update Form in the manual. Please contact TEREX Utilities Warranty Department at 1-844-837-3948 or utilities.warranty@terex.com or online at: <https://www.terex.com/utilities/en/support/product-registration>

Terex, OSHA and local industry standards, also require that the manufacturer's bulletins be completed. It is your responsibility to communicate this important information to all machine owners and applicable branches. If you require additional copies of this bulletin or have any questions, please contact Terex Utilities at 1-844-837-3948.

Reference Figures

Single 2-Man Basket

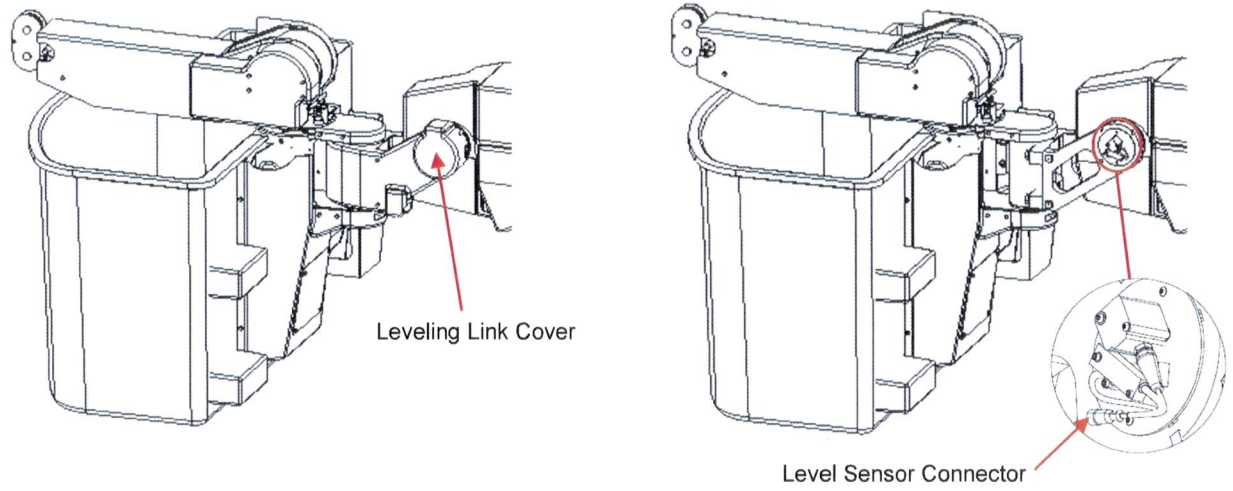

Figure 1. Remove Leveling Link Cover to inspect the power wire for the Level Sensor

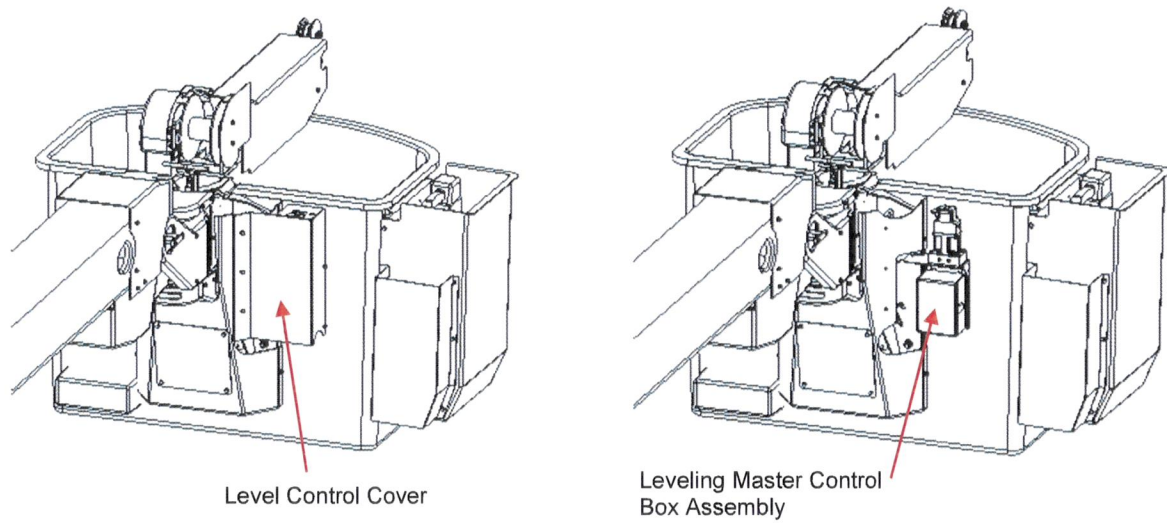

Figure 2. Remove Level Control Cover to inspect the power wire for the Level Sensor

Dual 1-Man Baskets

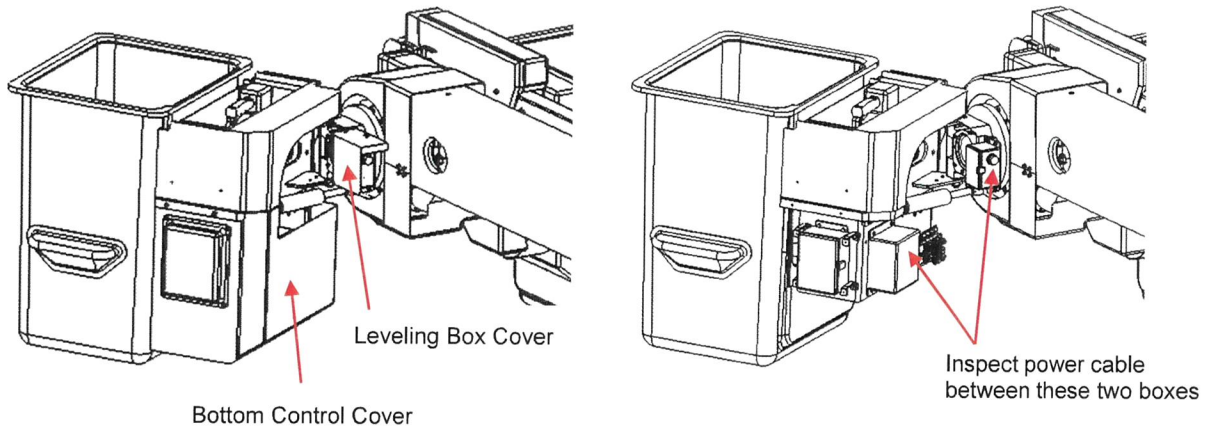

Figure 3. Rotate Operator's Basket out, remove Bottom Control Cover and Leveling Box Cover



January 31, 2025

'owner'

'address1'

'city', 'state' 'zip'

IMPORTANT SAFETY RECALL

NHTSA Recall No. 24V-438

This notice applies to your vehicle

Dear Terex Equipment Owner,

This notice is sent to you in accordance with the National Traffic and Motor Vehicle Safety Act.

REASON FOR NOTICE

Terex South Dakota, Inc. has decided that a defect, which relates to motor vehicle safety, exists in certain 2022 to 2023 TM model aerial devices, produced from June 16, 2022 through October 13, 2023. If electrical power is lost to the level sensor for the platform tilt controller, the platform may tilt in an uncontrolled manner while squeezing the unit control enable trigger. Tilting of the platform may cause the platform occupants to fall resulting in injury.

WHAT TEREX WILL DO

Terex will provide Field Service Kit Z1723, parts and labor, at no cost to the customer. The Field Service Kit Z1723 provides a replacement platform tilt controller. It will take approximately two (2) hours to remove the existing controller, install the replacement controller, and to test the machine.

Locate your nearest Terex Utilities Service Center by visiting our website at www.terexutilities.com and select the Service tab. To schedule repairs with Terex Utilities Field Service, call 1-844-837-3948. The Terex Utilities Warranty Department can also be reached at 1-844-837-3948 or by email at utilities.warranty@terex.com. Repairs can also be coordinated through our Dealer Service network as noted on the map included with this mailing.

WHAT THE OWNER MUST DO

1. Immediately inform all users, operators, and supervisors of the contents of the bulletin.
2. Deploy the outriggers and position the booms in the ground mount position clear of any obstacles; position with lower boom fully articulated and the upper boom articulated and extended so the basket is 6 inches to 12 inches above the ground.
3. Remove needed covers to verify that the power wire for the Level Sensor is securely connected to the sensor, is undamaged along its length, and routed so it cannot be pinched, see the figures in the bulletin as reference. Repair, replace, or re-route the power wire as required.
4. Standing on the ground beside the basket and clear of the path of motion of the basket, squeeze the upper control enable trigger.
 - a. If the basket begins tilting downward, release the enable trigger. Do not use the machine until corrected.
 - b. If the basket does not tilt while only squeezing the enable trigger, see the Continued Use section below.

Terex South Dakota, Inc.
3140 15th Ave SE
Watertown, SD 57201 USA
1-844-837-3948 • Fax 1-605-882-1842

5. After verifying the integrity of the power wire, re-install any removed covers. The unit can be used following the instructions in the Continued Use section below as well as all operator, maintenance, and inspection requirements as specified in the manuals.

CONTINUED USE

1. Inform the users of the content of the bulletin and remind them of the daily pre-shift inspection requirements.
2. Inform the users that personal fall protection equipment is required to be used whenever occupying the platform of an aerial device.
3. Repeat the checks from Steps 2 & 4 of the Action section above daily before the first use of the aerial device from the platform.
4. Inform the users that tilting of the platform due to the lost electrical signal to the level sensor will only occur when the single stick enable trigger is squeezed. **Releasing the enable trigger will stop the platform tilting.**
5. If the leveling system malfunctions, utilize the following procedure to correct the leveling system and stow the boom:
 - a. From the lower controls shut off the upper controls by rotating the "Top Control and Option Shut-Off" to the "OFF" position.
 - b. Use the lower controls to level platform and stow boom. With the "Top Control and Option Shut-Off" rotated to the "OFF" position, the platform will not level while operating the boom from the lower controls. Stop stowing operations as needed to level the platform using the level control.
 - c. Do not use the machine until the malfunction is repaired or the controller is replaced.
6. Always follow inspection and maintenance requirements as specified in the manuals.

If you have any questions you can find your nearest dealer at this web site;

<http://www.terex.com/utilities/en/products/dealer-locator/index.htm>.

If you take your unit to your dealer on the agreed service date and they do not remedy this condition on that date or within three (3) working days of scheduled appointment, we recommend you contact Terex Utilities Warranty department by calling 1-844-837-3948.

Note to Owners: If the manufacturer or their dealer has failed or is unable to remedy the defect/noncompliance condition without charge or within a reasonable amount of time you can notify:

Administrator
National Highway Traffic Safety Administration
1200 New Jersey Avenue, SE, West Building,
Washington, DC 20590

Or call the toll-free DOT auto Safety Hotline at 1-888-327-4236 (TTY: 1-800-424-9153; or go to <http://www.safercar.gov>.)

If you have had your unit repaired for this issue prior to receipt of this notice, you may be eligible for reimbursement. For more information, please contact Terex Utilities at the above contact information.

If you have sold or retired the unit please let us know by contacting the Terex Utilities Warranty department at 1-844-837-3948 or send the serial number and new owner contact information to utilities.warranty@terex.com. Forward this Notice and any other uncompleted bulletins to the new owner within 10 days of receipt of this letter.

If you have leased this vehicle to another person, forward a copy of this notice to the lessee within ten days of your receipt of this notice.

Thank you for your immediate attention on this important matter,

Rory Lindner
Warranty Manager

Our records indicate the following machines, registered to you, are involved in SN728.

Model	Serial Number	VIN #
'model'	'Serial number'	VIN #

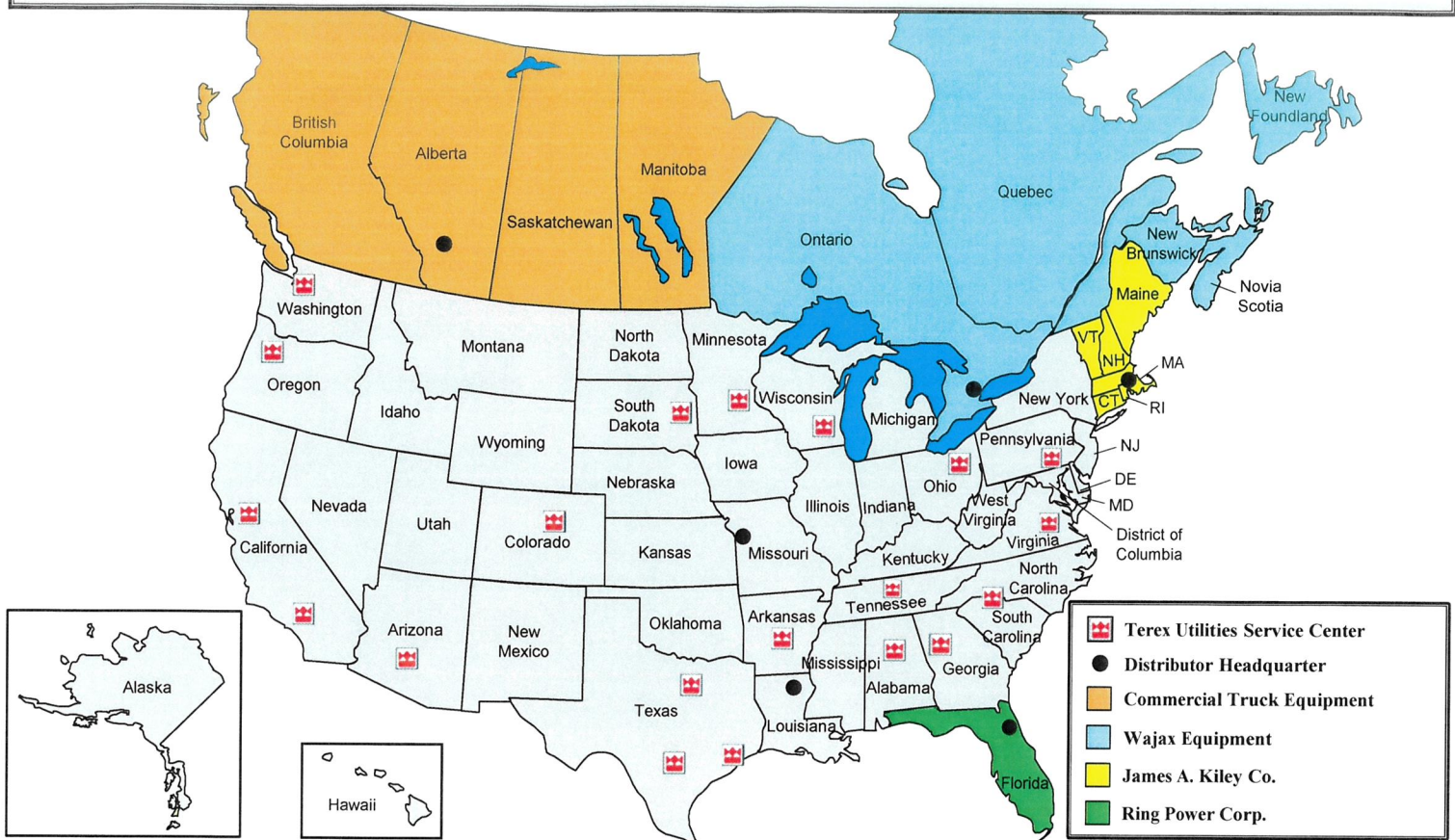

Terex Utilities Service Network



Terex Utilities		
Seattle 206.764.5025	Houston 346.261.3200	Medina 330.722.6900
7829 South 2016 th Street Kent, WA 98032	6610 Thompson Rd Baytown, TX 77521	1175 Industrial Parkway Medina, OH 44256
Portland 503.620.0611	N. Little Rock 501.945.6100	Waukesha 262.547.8500
12805 SW 77 th Place Tigard, OR 97223	309 Dixie Street North Little Rock, AR 72114	N4W22610 Bluemound Rd Waukesha, WI 53186
Stockton 209.242.7104	Birmingham 205.841.6411	Shakopee 952.445.1555
2610 Lycoming Street Stockton, CA 95206	4120 Lewisburg Rd Birmingham, AL 35207	12565 Hwy 41 Frontage Rd Shakopee, MN 55379
Fontana 909.565.1234	White House 615.672.4911	Watertown 605.882.3004
8594 Cherry Avenue Fontana, CA 92335	200 Edenway Dr White House, TN 37189	1901 14 th Avenue NW Watertown, SD 57201
Phoenix 602.256.0162	Charlotte 704.654.3903	Denver 303.202.0304
4920 W. Magnolia Street Phoenix, AZ 85043	11945 Goodrich Drive Charlotte, NC 28273	6295 E. 56 th Avenue Commerce City, CO 80022
Fort Worth 817.698.8005	Glen Allen 804.752.2811	Atlanta 470.291.1133
3155 S. Burleson Blvd. Burleson, TX 76028	11072 Washington Hwy Glen Allen, VA 23059	1400 Oakley Industrial Blvd Fairburn, GA 30213
San Antonio 210.476.7777	Lancaster 717.650.1044	Field Service 800.292.1931
142 Gemblar Rd San Antonio, TX 78219	180 N. Donnerville Rd, Suite B Mountville, PA 17554	

Distributors
Commercial Truck 877.915.9140
11199 48 St SE Calgary, AB T2C 5H4, Canada
Wajax Equipment 519.893.2942
2250 Argentia Rd Mississauga, ON L5N 6A5, Canada
James A. Kiley Co. 617.776.0344
15 Linwood Street Somerville, MA 02143-2188
Ring Power Co. 904.737.7730
500 World Commerce Pkwy St. Augustine, FL 32092
Scott Powerline 877.388.9269
3018 Harvester Drive Monroe, LA 71201
Custom Truck 833.281.7911
7701 Independence Ave Kansas City, MO 64125

Sample of window envelope, address shows through window.

 TEREX <i>Utilities</i> 3140 15 th Ave SE Watertown, SD 57201-9017	IMPORTANT SAFETY RECALL INFORMATION	
 U.S. Department of Transportation	Issued in Accordance With Federal Law	 ***** NHTSA <small>www.nhtsa.gov</small>
SAFETY RECALL NOTICE		
<p>"Customer's Name" "Address" "City", "State" "Zip Code"</p>		

Alternate format: Normal envelope, with address label or printed envelope.

 TEREX <i>Utilities</i> 3140 15 th Ave SE Watertown, SD 57201-9017	IMPORTANT SAFETY RECALL INFORMATION	
 U.S. Department of Transportation	Issued in Accordance With Federal Law	 ***** NHTSA <small>www.nhtsa.gov</small>
SAFETY RECALL NOTICE		
<p>"Customer's Name" "Address" "City", "State" "Zip Code"</p>		

