

IMPORTANT SAFETY RECALL INFORMATION



Issued in Accordance
With Federal Law



Corporate Compliance PO Box 30 Middlebury, In 46540

FOLLOW-UP NOTICE OF SAFETY DEFECT

Our records indicate your vehicle has not been remedied; for your Safety and the Safety of others, please have your vehicles' recall remedied as soon as possible.

NHTSA RECALL: 24V103
CANADA RECALL: 2024-086
FR ID: 68-1736

<<VIN>>
<<OWNER NAME/DEALERNAME>>
<<ADDRESS>>
<<CITY>>, <<ST>> <<ZIP-XXX>>

June 2025

This Notice applies to your vehicle VIN listed above.

Dear Forest River Customer:

This notice is sent to you in accordance with the requirements of the *Motor Vehicle Safety Act*. This notice is also sent to you in accordance with the requirements of the United States' *National Traffic and Motor Vehicle Safety Act*. Forest has decided that a defect, which relates to the motor vehicle safety, exists in certain 2019-2024 Georgetown and FR3 Class A Motorhome Recreational Vehicles. This is to inform you that your vehicle may contain a defect that could affect the safety of a person.

WHAT IS THE DEFECT/NONCOMPLIANCE?

The brackets that secure the propane tank could fail. As a result, the propane tank could become damaged and/or detach. If this happens, the tank could leak propane.

EVALUATION OF THE RISK TO THE VEHICLE AND OPERATOR(S) RELATED TO THE RECALL.

A propane gas leak could create the risk of a fire or explosion. Additionally, a propane tank that detaches from the motorhome could create a road hazard for others and increase the risk of a crash

WHAT IS FOREST RIVER AND OUR DEALERSHIPS GOING TO DO?

Forest River is notifying dealerships of the recall. You may have the recall corrected at any Forest River dealership. However, it is preferable if you have your selling dealership perform the remedy. Forest River completely covers your cost for the remedy; you will not receive any bill of sale for anything covered under the above recall number.

WHAT SHOULD YOU DO?

Please reference the enclosed inspection procedure. Follow the instructions for the inspection of the LPG tank brackets' welds and bend. Once we receive the information, a representative will be in touch with you if further action is required. If you are not comfortable with performing the inspection, you may take your vehicle to your dealer, and they will perform the inspection. The vehicle Owner is responsible for arranging to have the work completed. Please state you have been notified by Forest River of having a recall in process for your vehicle and provide the recall number for the dealership. It is also helpful to the dealership to have a copy of this letter when you take your vehicle in for the recall remedy. You may also visit www.forestriverinc.com for dealer locations.

HOW LONG WILL THE REMEDY PROCESS TAKE?

The estimated time of repair is .20 hours. However, the dealership may need to keep your vehicle or schedule an appointment with you for a later date to fit into their regular service schedule.

WHAT IF YOU HAVE PREVIOUSLY PAID FOR REPAIRS TO YOUR VEHICLE FOR THIS PARTICULAR CONDITION?

If you have already paid for a repair that is within the scope of this defect under recall, you still need to have this recall inspected and/or performed to ensure the correct parts and procedures were utilized.

Additionally, you may be eligible for a refund of previously paid repairs. Refunds will only be provided for within the scope of this defect under recall.

IMPORTANT SAFETY RECALL INFORMATION



Issued in Accordance
With Federal Law



Please send the service invoice to the following address:

Georgetown & FR3
Forest River, Inc.
Attn: WARRANTY MANAGER
55135 CR 1
Elkhart, IN 46514

WHAT IF YOU NO LONGER OWN THIS VEHICLE?

If you no longer own this vehicle and have the address for the current owner, please forward this letter to the new owner within 10 working days after the day in which the notice is received. You have received this letter because government regulations require that a notification is sent to the last known owner of record. Our records indicate that you are the current owner.

PLEASE NOTE: FEDERAL LAW REQUIRES THAT ANY VEHICLE LESSOR RECEIVING THIS RECALL NOTICE MUST FORWARD A COPY OF THIS NOTICE TO THE LESSEE WITHIN TEN DAYS.

WHAT IF I HAVE ALREADY HAD THIS RECALL PERFORMED?

Please provide a copy of the work order, or invoice showing the recall was performed. Please ensure the VIN is visible on the paperwork and send it to:

Email: occinfo@forestriverinc.com

Mail: Forest River Office of Corporate Compliance
PO Box 30 Middlebury, IN 46540

MAY FOREST RIVER ASSIST YOU FURTHER?

If you have difficulties getting your vehicle repaired, please contact your Forest River Representative listed below:

CONTACT	PHONE
CUSTOMER SERVICE	574-206-7600

If after contacting your dealer and/or our customer care helpline, you have additional questions regarding this recall, you may contact:

For US Owners Please Contact:

Administrator
National Highway Traffic Safety Administration
1200 New Jersey Ave, S.E.
Washington, D.C. 20590

Or you may call the toll free Vehicle Safety Hotline
at 1-888-327-4236 or (TTY: 1-800-424-9153).

Or visit www.safercar.gov and search;
Recall ID: 24V103

For Canadian Owners Please Contact:

Head of Recalls
Motor Vehicle Safety Investigations Laboratory
Transport Canada
80 Noël street, Gatineau, Quebec, J8Z 0A1

Telephone (800) 333-0510

Facsimile (819) 420-4292

Recall ID: 2024-086

Sincerely,
Forest River Inc.
Office of Corporate Compliance

RECALL 24V103 / 2024-086 INSPECTION INSTRUCTIONS



Make(s): FR3 & GEORGETOWN
Model(s): ALL MODELS
Model Year(s): 2019 - 2024

Concern:
The two mounting ("L") brackets which the LPG tank is bolted to may fracture within the radius bend, and it is possible there is a lack of weld connecting the L Bracket to the chassis.

Repair Code: N/A
Allotted Time: N/A
Inspection Code: RC-026-05-00-004487
Allotted Time: .20 HRS.
Photo(s) Required: YES, SEE BELOW
Prior Authorization Required: NO
Part(s) Kit Number: N/A
Part(s) Return: YES, SEE BELOW

Turn off LP Gas at LPG Tank(s). Place vehicle in (P) Park and engage the Parking Brake. Disconnect the vehicles' battery Positive and Negative, disconnect any House battery(s) Positive and Negative, if equipped with a generator ensure it is off and lastly, ensure the vehicle is disconnected from shore power. Block any tires/wheels to prevent the vehicle from rolling. Failure to do so may result in electrocution, fire or other personal injury, property damage and/or death.

STEP 1: OPEN THE LPG COMPARTMENT;

STEP 2: USE GLASS CLEANER AND A CLOTH, BRUSH, RAG, OR ANYTHING ELSE NEEDED TO REMOVE DUST AND ROAD GRIME FROM THE "L" BRACKETS THAT THE LPG TANK IS BOLTED TO;

STEP 3: TAKE A PHOTO OF EACH BRACKET;

- ENSURE TO CAPTURE THE BRACKET; FIGURE 1
- ENSURE THE FOCUS OF THE PHOTO IS OF THE BEND/RADIUS; FIGURE 1
- THIS SHOULD BE TWO (2) PHOTOS (FRONT BRACKET AND REAR BRACKET);

STEP 4: TAKE A PHOTO OF EACH BRACKET AND ITS WELDS;

- ENSURE TO CAPTURE THE BRACKET AND WELDS; FIGURE 2
- ENSURE THE FOCUS OF THE PHOTO CAPTURES GOOD VISUALS OF THE BRACKET WELDS; FIGURE 2
- THIS SHOULD BE TWO (2) PHOTOS (FRONT BRACKET AND REAR BRACKET);

STEP 5: SCAN THE QR CODE AND UPLOAD THE PHOTOS;

- THE VIN IS REQUIRED FOR SUBMISSION;

STEP 6: SCAN THE QR CODE BELOW;

- CAPTURE FOUR PHOTOS AND SUBMIT TO THE PORTAL;
- ENSURE YOU HAVE THE FORD VIN AVAILABLE;



NOTE: FOREST RIVER AND ITS PARTNER SUPPLIER WILL REVIEW PHOTOS. IF FURTHER ACTION IS NEEDED, YOU WILL BE NOTIFIED.

RECALL 24V103 / 2024-086 INSPECTION INSTRUCTIONS



Make(s): FR3 & GEORGETOWN
Model(s): ALL MODELS
Model Year(s): 2019 - 2024

Concern:
The two mounting ("L") brackets which the LPG tank is bolted to may fracture within the radius bend, and it is possible there is a lack of weld connecting the L Bracket to the chassis.

Repair Code: N/A
Allotted Time: N/A
Inspection Code: RC-026-05-00-004487
Allotted Time: .20 HRS.

Photo(s) Required: YES, SEE BELOW
Prior Authorization Required: NO
Part(s) Kit Number: N/A
Part(s) Return: YES, SEE BELOW

FIGURE 1 (ONLY SHOWING THE FRONT SIDE)

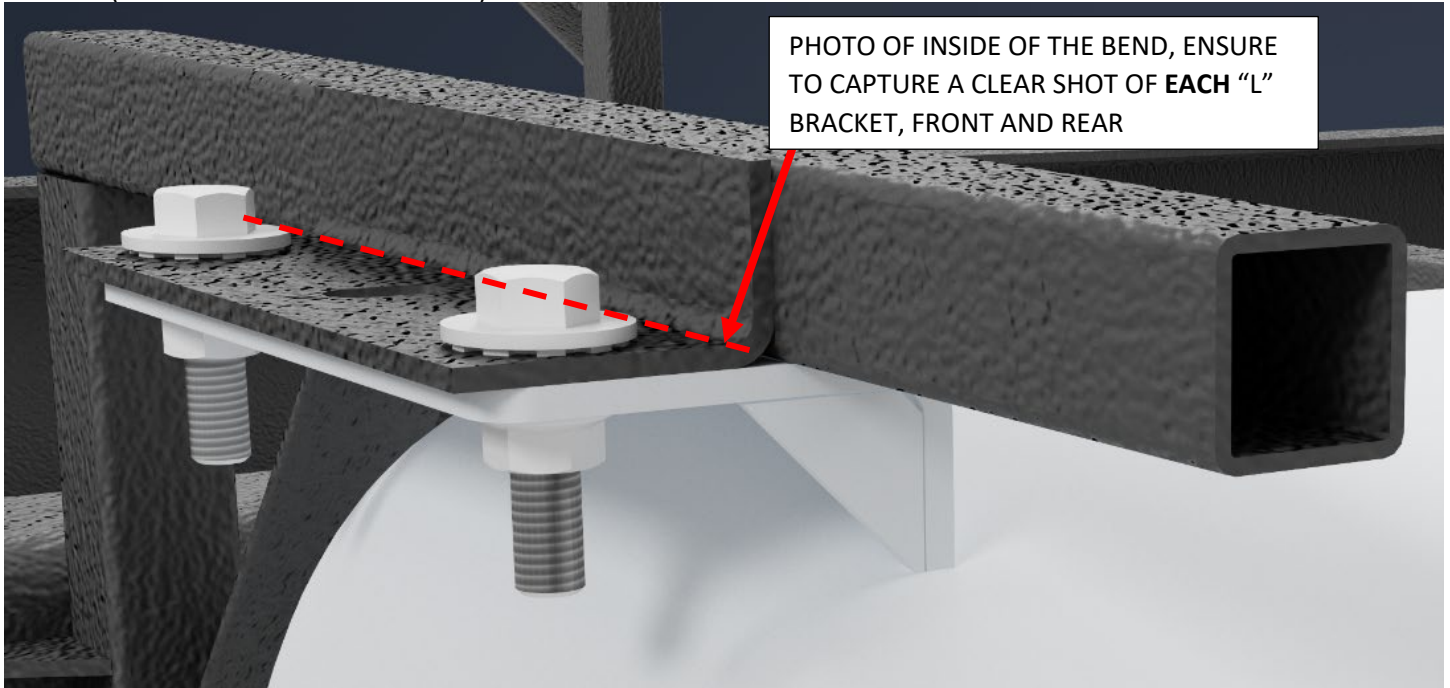

FIGURE 2 (ONLY SHOWING THE FRONT SIDE)

