

Recall Campaign Bulletin



Mercedes-Benz

Campaign No. 2025010005, January 2025

TO: ALL MERCEDES-BENZ CENTERS

SUBJECT: **Model EQS (296 platform)**
Model Year 2023

Replace Mounting Brackets in Roof

Mercedes-Benz AG, the manufacturer of Mercedes-Benz vehicles, has determined that on a certain MY 2023 EQS (296 platform) vehicle, the mounting brackets in the roof might not meet current production specifications. In the event of a crash with side-curtain airbag deployment, the airbag cushion material could become damaged by sharp edges on the mounting brackets. As a consequence, the effectiveness of the side-curtain airbags might be impaired and the risk of injury for vehicle occupants might increase. An authorized Mercedes-Benz dealer will replace the mounting brackets on the affected vehicle and check the side-curtain airbags for damage and replace them, if necessary.

Prior to performing this Campaign:

- **VMI must be checked before performing campaigns to verify that the campaign is required on a specific vehicle. Always check for any other open campaigns and perform accordingly.**
- Please review the entire Campaign bulletin and follow the repair procedure exactly as described.

Approximately 1 vehicle is affected.

Order No. P-RC-2025010005

Recall Campaign Bulletin

Recall Campaign Bulletin

Recall Campaign Bulletin

Recall Campaign Bulletin

Recall Campaign Bulletin

Replace Mounting Brackets in Roof

Model: 296

Check/Test Procedure

1. Adjust driver and front passenger seat to fully reclined position.
2. Remove headliner and place on the seat backrests.
i For basic information, see AR68.30-P-4300EQS.
3. Loosen the clips (**Figure 1, 1**) on the left and right window airbag (**Figure 1, 3**).
i To do so, press together tabs (**Figure 1, 2 & A**) using suitable needle nose pliers, and remove clips (**Figure 1, 1**).
NOTE: A relatively large amount of force will be required to remove the clips (**Figure 1, 1**).

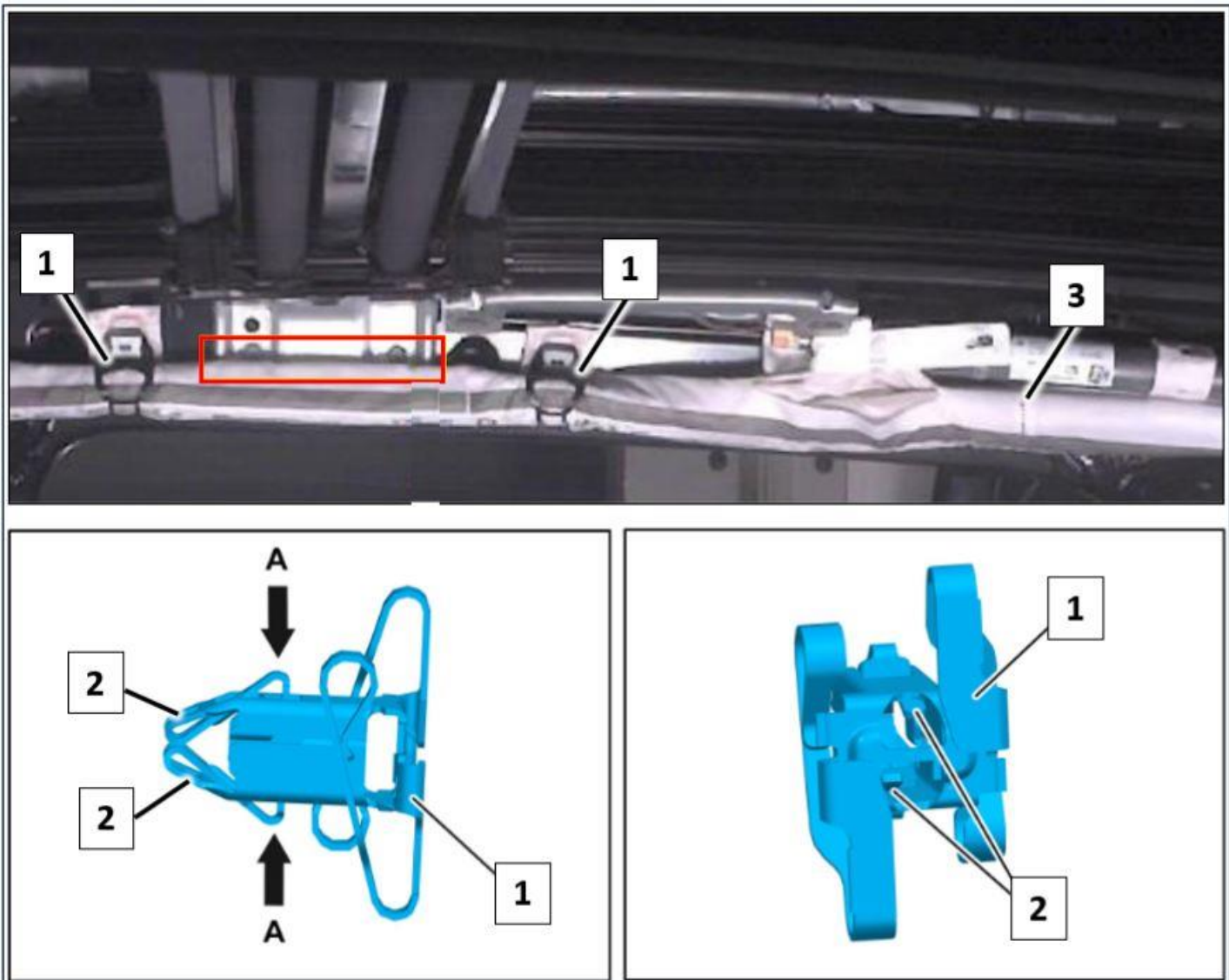

Figure 1

4. Check contact surface of the window airbag sleeve on the left and right window airbags (**Figure 2, 3**) for damage.
i Check lower area of mounting bracket edge (**Figure 2 and 3, B**) for damage.

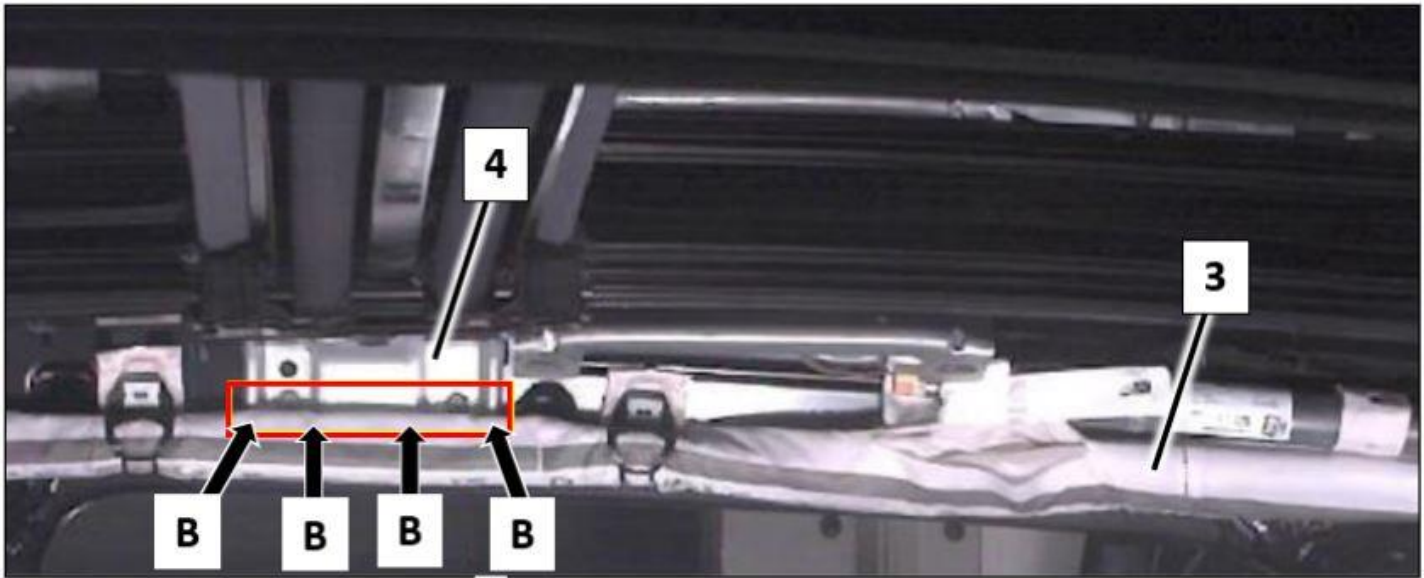

Figure 2

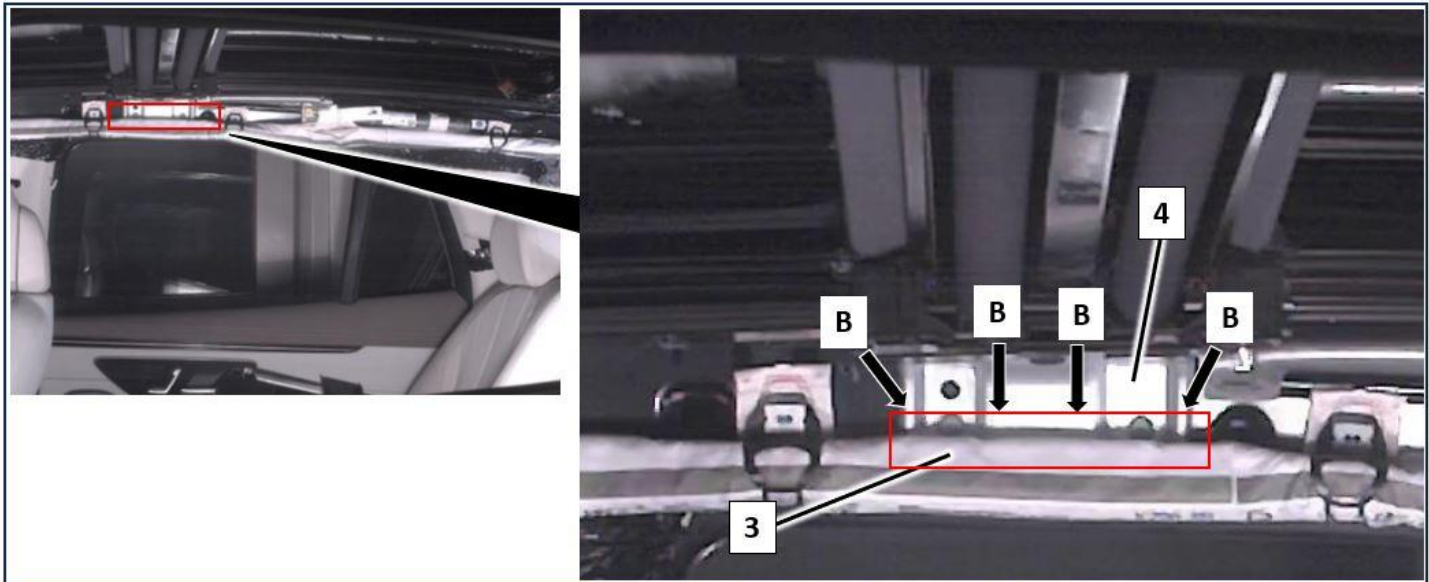

Figure 3

- a. If window airbag sleeve (**Figure 2 and 3, 3**) is **not damaged**, only perform **Work Procedure A**.
- b. If window airbag sleeve (**Figure 2 and 3, 3**) is **damaged**, perform **Work Procedure A and B**.

Work Procedure A

5. Replace mounting bracket (**Figure 4, 4**) on left and right B-pillar.

i To do so, unscrew mounting bracket screws (**Figure 4, C**) on left and right B-pillar (**Figure 4, 4**).

Nm Observe tightening torque of screws: **8 Nm**.

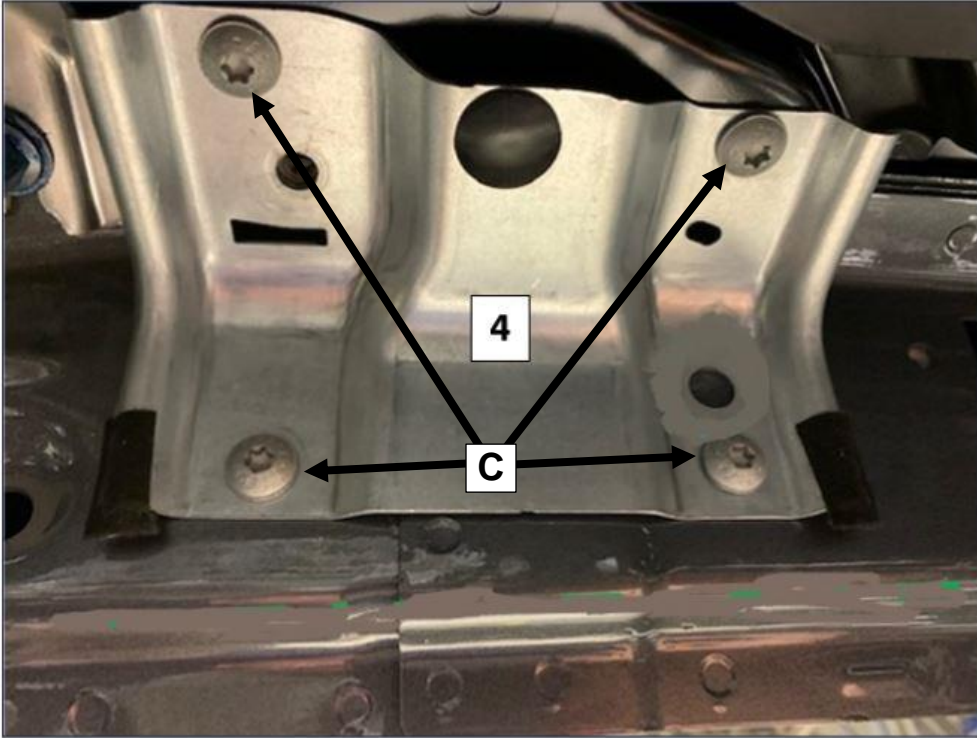

Figure 4

Work Procedure B

6. Replace damaged window airbag(s) (**Figure 1 and 2, 3**).

i For basic information, see AR91.60-P-0693EQS and AH91.00-Z-0000-10A.

7. Install in the reverse order.

Primary Parts Information

Qty.	Part Name	Part Number
1	Left B-pillar mounting bracket	A 296 787 0500
1	Right B-pillar mounting bracket	A 296 787 06 00
As required (1)	Window airbag, left	A 296 860 54 00
As required (1)	Window airbag, right	A 296 860 55 00

i *Dispose of replaced component parts following local legal requirements.*

i *Small parts such as screws, lock nuts, sealing rings, cable ties, fluids, sealant, etc. are not listed in the parts list. The required small parts are taken into account in the budgeting.*

i **Note:** *The following allowable labor operation should be used when submitting a warranty claim for this repair:*

Warranty Information

Damage Code	Operation Number	Description	Labor Time (hrs.)
72 902 07	12-2342	Operations: Replace mounting brackets on left and right B-pillar and check window airbags for damage Includes: Remove/install headliner, remove/install divider, remove/install tilting/sliding roof and roller sunblind	4.0
	12-2343*	Operations: Replace one window airbag (after check) Includes: Connect XENTRY Diagnosis and perform quick test, connect/disconnect ground cable of 12 V on-board electrical system battery	0.6
	12-2344*	Operations: Replace two window airbags (after check) Includes: Connect XENTRY Diagnosis and perform quick test, connect/disconnect ground cable of 12 V on-board electrical system battery	0.7

* *Invoice operation item only once for each workshop order.*

i **Note:** *Always check Xentry Operation Time (XOT) for the current OP-Code times. Labor times are subject to change and updates may not be reflected in this document.*