



Campaign code:

L74X-R.03.24

Campaign name:

Rear oil cooler pipe tightening check

Model:

Revuelto

Model Year:

2024

Markets:

USA, Canada, Netherlands, France, South Africa, Romania, United Kingdom, Germany

VIN Involved:

From 116 to 1846

Important information: before proceeding with the repair, connect to the Warranty Portal and, using the “VIN Info” function, check that:

- the vehicle is actually affected by the instructions contained in this bulletin.

NOTE: some vehicles may not be affected, despite the fact that their Vehicle Identification Number (VIN) falls within the range;

- only replacement parts that correspond to the specific operation, identified by a letter (such as A, B, C, etc.), are to be used for the chassis being repaired.

Example

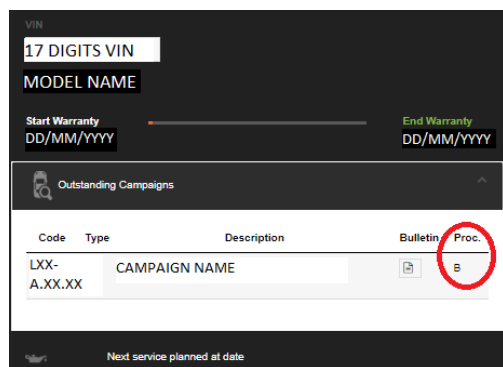

NOTE:

Operation A will be available only when the instructions require a preliminary check to be performed to determine whether or not the vehicle actually needs updating.

Information for the service network:

During ongoing product monitoring, Automobili Lamborghini S.p.A. identified a potential issue on some vehicles that have been reworked internally and has released a new mandatory update for the potentially affected cars for the verification of the correct tightening torque of the oil cooler pipe.

Solution for the field:

Checking the flange tightening torque of the oil cooler pipe

Spare Parts:

OPERATION B

| Part number | Description | Q.ty |
|-------------|-------------|------|
| n/a | n/a | n/a |

Management of replaced parts:

Store the components that have been removed from the vehicle in an appropriate manner, marking them with their corresponding bar codes so that they can be identified during visits by the competent Area Manager.

Labor time:

Operation B: 0,3 h

Previous bulletins superseded.

None.

Warranty claim instructions:

To request reimbursement for the repair performed, access the “LIASS” system on the Lamborghini portal and, following the



instructions in the system’s “Manuals” section, generate and fill out a Warranty Request. Select the required campaign and proceed with entry; carefully read the options present in the alert message that displayed by the system (see example) and select the option performed on the vehicle.

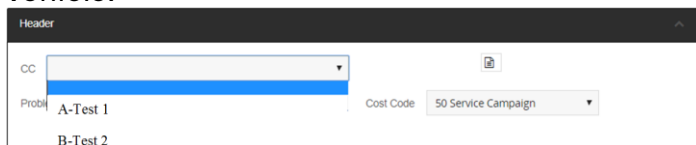

Reimbursement will be structured as follows, on the basis of the operation performed:

- **OPERATION B:**
 - o Steps to be executed: from 1 to 2
 - o Labour time: 0,3h

Important information:

attach all documents generated during the work carried out, evidence of the work itself, for instance work orders and diagnostic protocols with BETA-Reports.

If one or more of these is missing, it may lead to a rejected reimbursement request.

Fill out the page in the warranty booklet (identified in the image below) in the section “Service and Recall Campaigns”:

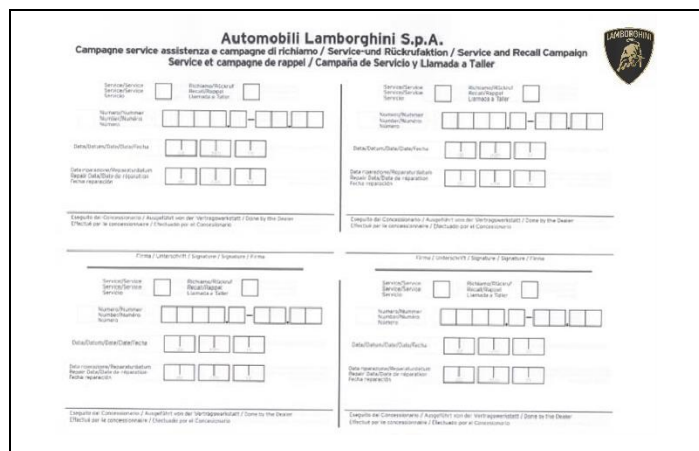

Tools/Materials required

| Code | Description. | Q.ty |
|------|--------------|------|
| n\ a | n\ a | n\ a |



NOTE:

All ODIS technical documentation can be viewed on the Lamborghini web portal, in the ODIS section.



Repair method:

OPERATION B

Follow the instructions in the following steps:

1. Open the engine hood.
2. Verify that the tightening torque of the two M6X20 screws (1) is 10.00 Nm \pm 5% (7.38 lbf ft).

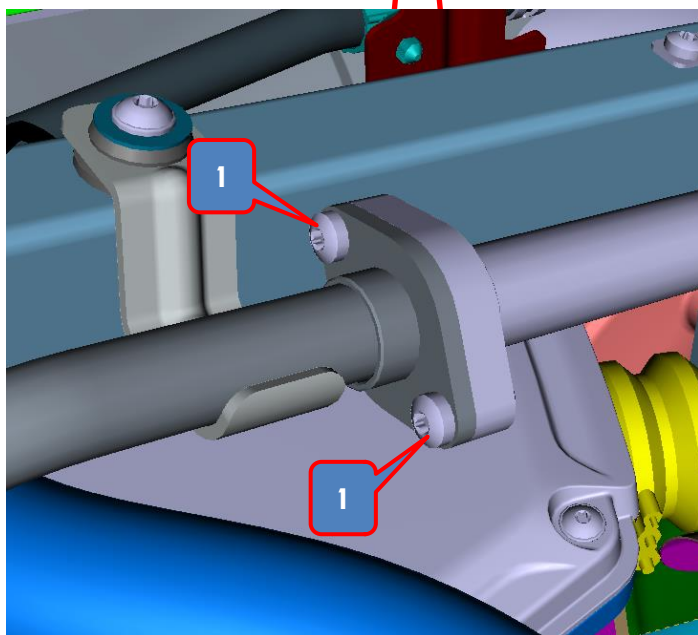
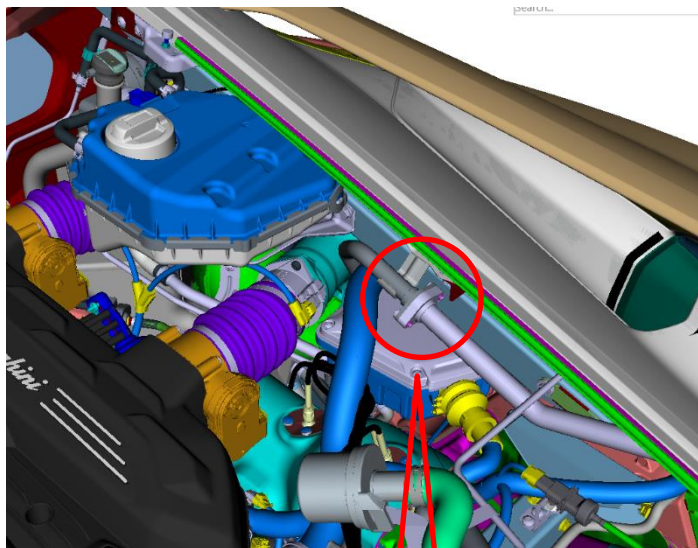

IMPORTANT:

The documents which must be provided together with the operation under warranty request are:

- *Produced Repair Order*
- *Saved Diagnostic Protocol with BETA report*

Failure to follow these procedures could lead to the request being rejected.

For more information, please contact your Area Manager or open a ticket to Technical Support in Lamborghini KEY (Request – General Information – After Sales Services - After Sales Technical Support).

Regards,
Lamborghini Service