



Service Bulletin

American Honda Motor Co., Inc.

NCW50 #1
Revised February 2025

SAFETY RECALL

2016 - 2025 NCW50 Metropolitan Transmission Case

BACKGROUND

Honda is launching a **SAFETY RECALL** on **CERTAIN** 2016-2025 NCW50 Metropolitan scooters to inspect the transmission for a potential oil leak.

Due to a manufacturing defect, the transmission case may not seal correctly to the engine causing a transmission oil leak and eventual transmission failure. This defect may cause the rear wheel to lock up and rapidly decelerate while riding, potentially increasing the risk of a crash or injury.

AFFECTED UNITS

CERTAIN NEW or USED 2016-2025 NCW50 Metropolitan scooters.

- To search for applicable recalls on a specific unit, you **MUST** use *Unit Information on iN*.
- To manage your affected new inventory, use your dealer *eResponsibility Report on iN*.

CUSTOMER NOTIFICATION

American Honda intends to mail customer letters to all owners of affected 2016-2025 NCW50 Metropolitan scooters in December 2024. Customers will be informed that their scooter may be affected by a safety related defect and will be advised to make an appointment with an authorized Honda dealer for repair.

DEALER REPAIR RESPONSIBILITY

- Repairs must be performed by a qualified technician.
- Performing this repair exactly as shown in Repair Procedure instructions is critical for the remedy to be effective. Carefully follow all instructions.
- Service Management should inspect and confirm the repair.
- Dealer submission of a warranty claim affirms this repair was properly performed.

PARTS INFORMATION

The Inspection Kit must be ordered for all affected units and be ordered using normal parts ordering procedures.

If an affected unit fails the INSPECTION on page 4, you must order the Repair Kit in addition to the Inspection Kit. **The Repair Kit is under TechLine control.** You must contact TechLine to order the Repair Kit.

NEW

NOTE: Some Inspection Kits have been found to have missing sandpaper discs. If the sandpaper discs are missing from a kit, you can use the new, unused discs from another Inspection Kit (for a unit that did not require them), or you can make your own by cutting out a 14 mm diameter circle out of 80-grit sandpaper, and then cutting a 6 mm center hole out of the middle.

Part Name	Part Number	Qty.
Inspection Kit	06114-GGZ-315	1
The Inspection Kit includes the following parts:		
Gasket, Exhaust Pipe	18291-GGM-901	1
Gasket, L Cover	11395-GGZ-J00	1
Washer, 8mm	90474-333-000	1
Bolt, Socket 6x40	90113-K2L-D00	1
Sandpaper Disc #80	N/A	1

Repair Kit	Part Number	Qty.	
Repair Kit	06115-GGZ-315	1	
The Repair Kit includes the following parts:			
Includes:	Brg Comp, Transmission Case	21000-GGZ -305	1
	Brg, ball Radial 6201	91006-KZR -601	2
	Brg, ball Radial 6203 Uu	91008-GGZ -J01	1
	Oil Seal, 24x40x7	91205-GGZ -J01	1
	O-ring, 14.8 x 2.4	91303-K27-V01	1
	Shaft, drive	23411-GGZ -J00	1
	Gear, counter	23422-GGZ -J40	1
	Shaft, counter	23421-GGZ-J00	1
	Gear Comp, final	23430-GGZ-J40	1
	Brg, ball Radial 6203 C3	96100-62033-00	1
	Brg, ball Radial 6201	91006-KZR-601	1
	Brg, ball Radial 6202	96100-62020-00	1
	Oil Seal, 17x30x5	91204-GGZ-J01	1
	Bolt, flange 6x40	90102-GGZ-J00	1
	Dust Seal, Brake Cam	45134-250-000	1

WARRANTY CLAIM INFORMATION

After completing this *Service Bulletin* repair, submit one warranty claim per unit with the applicable template number.

YEAR	MODEL	TEMPLATE	FLAT RATE
2016-2025	NCW50	Repair #1: Inspection only. KROA	1.4
		Repair #2: Inspection and grinding of crankcase. KROB	1.5
		Repair #3: Inspection and replace transmission case. KROC	2.2
		Repair #4: Inspection, grinding of crankcase and replace transmission case. KROD	2.3

Notes:

All warranty template claims will reimburse for engine oil required to refill the transmission case.

All warranty template claims will reimburse freight. To ensure your dealership receives the freight credit, follow these steps.

1. Make sure 'YES' is selected from the *Freight Involved* drop down window.
2. Make sure to include the *Part Order Reference Number*.
3. Include the freight *Amount* associated with the listed *Part Order Reference Number*.
 - The *Part Order Reference Number* can be found on your *Parts Order Statement* on *iN*.

• = Required

Template Warranty Claim

Template Number*

Basic Claim Information (required for all claim types)

Claim No.*

Repair Order Number*

VIN* Repair Order Date (open)*

Mileage* Work Completed Date*

Sublet Involved?

Freight Involved? Freight Information

Part Order Reference Number* Amount*

Submit Save View Claim CHANGE CLAIM TYPE

DEALER SUPPORT

TECHNICAL QUESTIONS

If you have any technical questions relating to this update procedure, please contact: Motorcycle TechLine Online:

iN > ***Service*** > ***TechLine*** > ***TechLine Connect***
Or call (800) 421-1900, option 9

WARRANTY QUESTIONS

If you have any warranty administration questions relating to warranty claim templates, and claim filing procedures, please contact:

Motorcycle Warranty Online:

iN > ***Service*** > ***Warranty & HondaCare*** > ***Warranty Connect Filing***
Or call (800) 421-1900, option 7

REPAIR IDENTIFICATION

To confirm this recall has been completed on an affected unit, you **MUST** use *Unit Information* on *iN*.

There is no campaign label or identifying marking on the scooter that indicates this safety recall has been completed.

REPAIR OVERVIEW

It is recommended to **read this service bulletin entirely before beginning work** to understand what may be required.

There are four possible repairs for this transmission oil leak. All repair options require performing an initial inspection of:

- Measuring the volume of transmission oil in the transmission case.
- Inspecting the left crankcase to ensure the bolt hole seating (sealing) surfaces are smooth and properly machined for flatness.

The results of the inspection will determine which repair option must be performed. The four repair options are defined as follows:

Repair #1: The transmission has **50 ~ 100 cc** of oil, and the left crankcase bolt hole surface is correctly machined.

Repair #2: The transmission has **50 ~ 100 cc** of oil in the case, and the left crankcase bolt hole surface fails inspection and must be repaired.

Repair #3: The transmission has **less than 50 cc** of oil in the case, and the left crankcase bolt hole surface is correctly machined.

Repair #4: The transmission has **less than 50 cc** of oil in the case, and the left crankcase bolt hole surface fails inspection and must be repaired.

Complete the **INSPECTION** beginning on this page and then use the **CONCLUSION** information at the end of the inspection (page 9) to determine which of the four repairs an affected unit requires.

INSPECTION

Complete the following steps to drain the transmission case oil into a suitable clean container, such as a metal drain pan.

Be careful to not spill any oil. You must accurately measure the volume of oil that is removed from the transmission case.

1. Remove the muffler:

Remove the two joint nuts [1], two bracket bolts [2] and muffler [3].

Remove the exhaust pipe gasket [4] from the exhaust pipe flange and replace it with a new one.

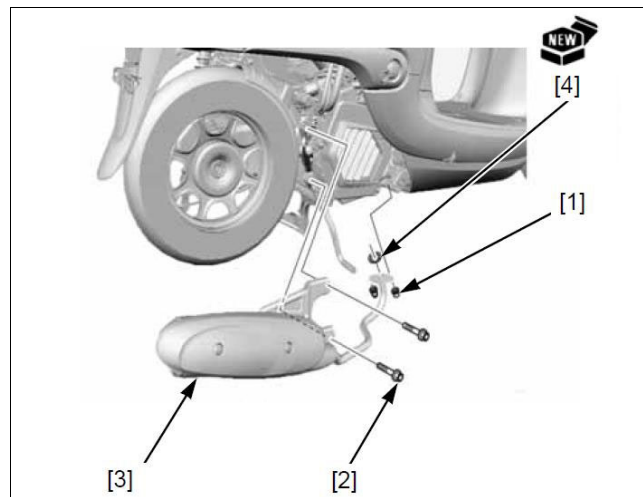

2. Remove the rear wheel:

Lower the rear wheel to the ground and set the rear brake, then loosen the axle nut [1]. Remove the rear axle nut, washer [2] and rear wheel [3].



3. Remove the brake shoes, shoe springs, brake cable adjusting nut, and joint pin (shown in green).

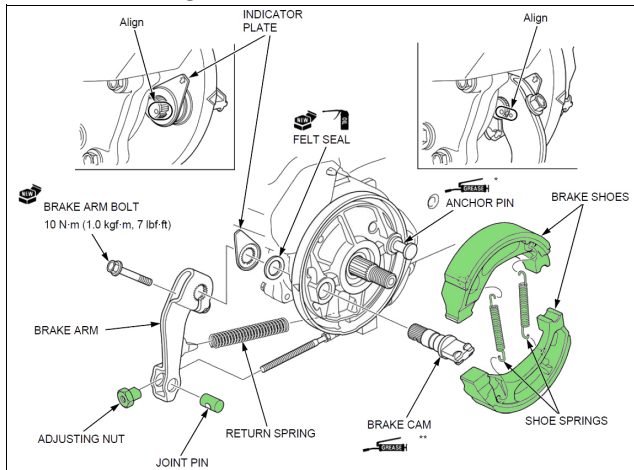

4. Remove the left crankcase cover:

Remove the six left crankcase cover special bolts [1], mount rubbers [2], and left crankcase cover [3].

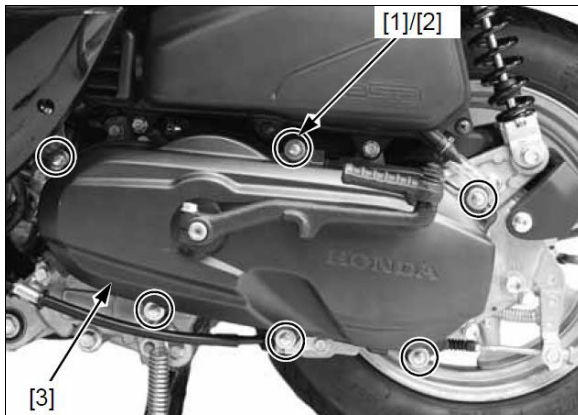

5. To remove the drive pulley, begin by removing the following:

- Bolt [1]
- Rear brake cable clamp [2]
- Bolt [3]
- Rear brake cable holder [4]
- Rear brake cable [5]

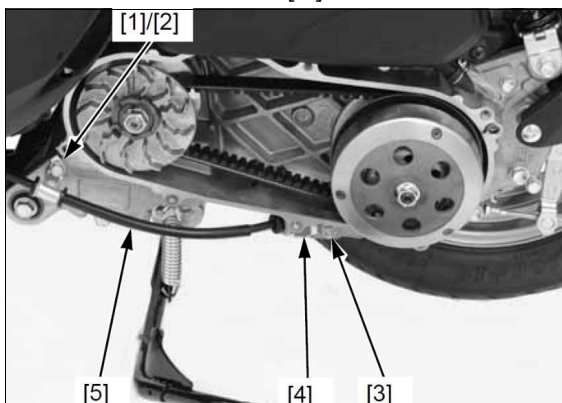

Hold the drive pulley face [1] with special tool and loosen the drive pulley face nut [2].

TOOL:

[3] Clutch center holder 07725-0030000

Remove the following:

- Drive pulley face nut
- Washer [4]
- Ratchet plate [5]
- Drive pulley face [1]

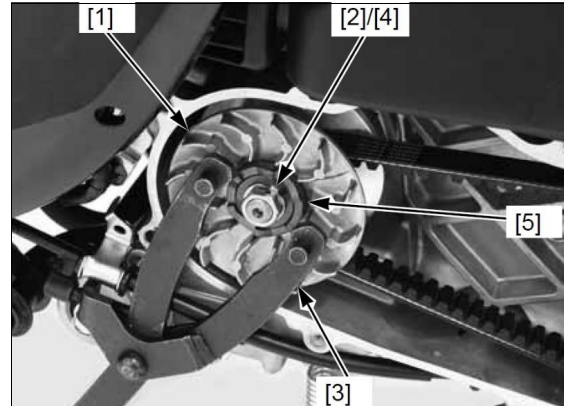

Release the drive belt [1] from the drive pulley boss [2].

Remove the movable drive face assembly [3] while holding the back of the face (ramp plate [4]) and drive face boss.

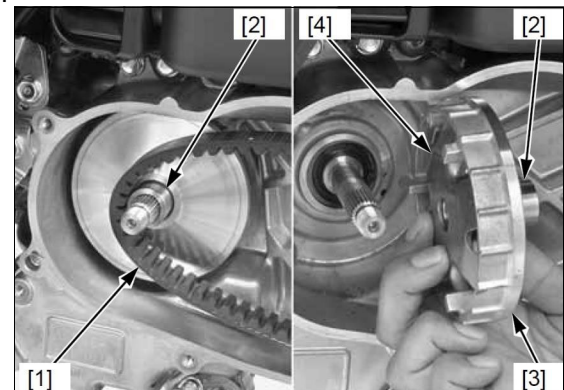

6. Remove the driven pulley face.
Hold the clutch outer [1] with the special tool.

TOOL:
[2] Flywheel holder 07725-0040001

Remove the nut [3] and clutch outer.
*Use the special tool when loosening the lock nut. Holding the rear wheel or rear brake will damage the final reduction system.

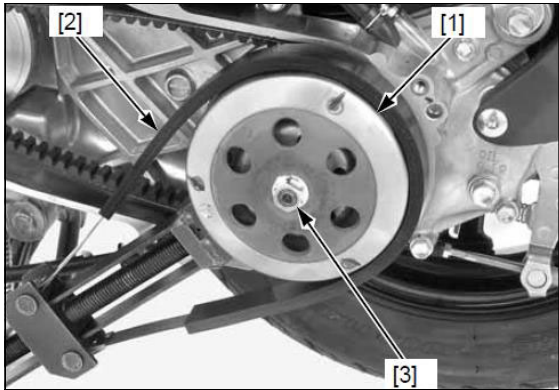

Remove the clutch/driven pulley assembly [1] and drive belt [2].

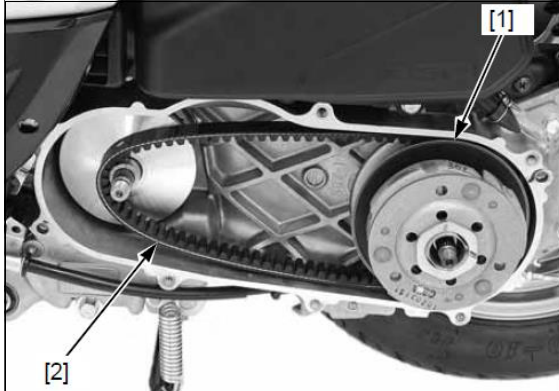

7. Remove the VS Sensor Protector and VS Sensor:

Remove the air cleaner case fixing bolt.

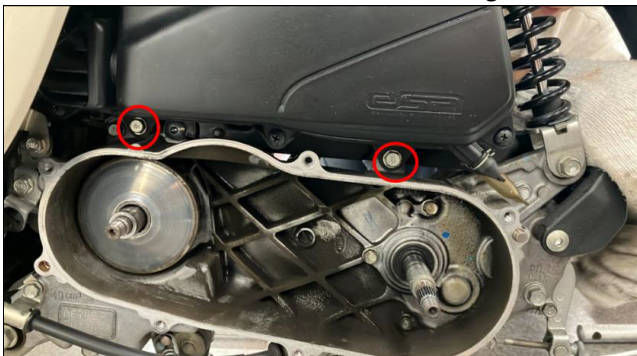

Remove the socket bolt tightening the sensor protector.



Release the wire band boss [2] from the sensor protector [3].

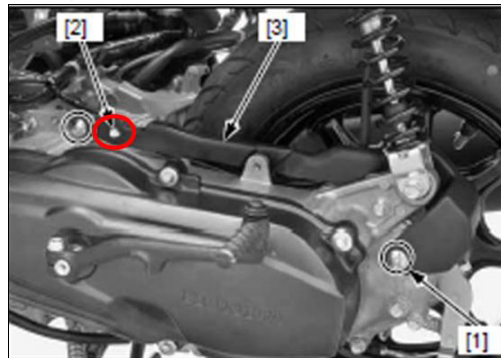

Pull out transmission case breather hose [3] and remove sensor protector.

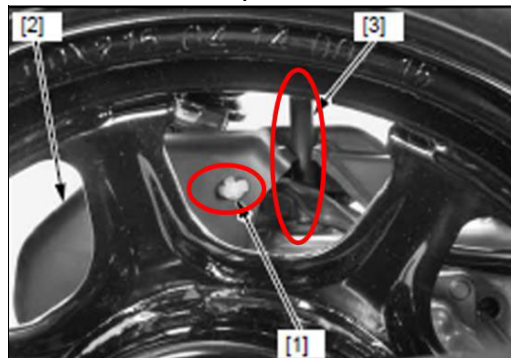

8. Remove the VS sensor:

Disconnect the VS sensor 3P (Black) connector [1].

Remove the bolt [2] and VS sensor [3].

Remove the O-ring [4] from the VS sensor groove.

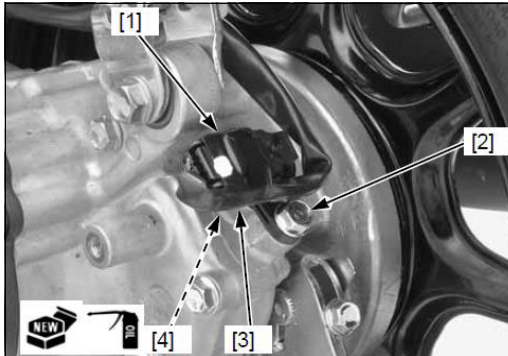

9. Release the rear brake cable [1] from the transmission case.

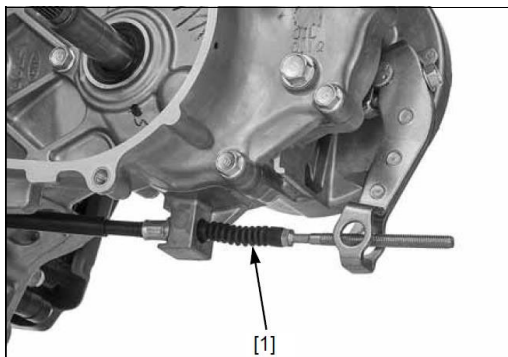

10. **Before continuing to step 11**, place a suitable clean oil collection pan below the transmission case to collect the transmission oil as it drains during transmission case removal. **Take care not to spill any oil as it will affect your measurement.**

11. Remove the transmission case:

Remove the transmission case bolts [1] and transmission case [2].

Place the transmission case **face down** to collect any remaining oil in the case.

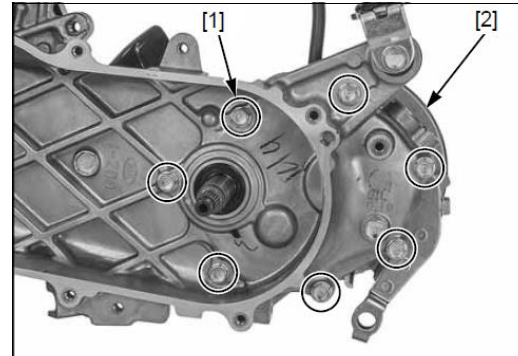

Remove the dowel pins [1], counter gear [2], countershaft [3], and final gear shaft [4] and place the gears/shaft in the oil collection pan to capture any residual oil on the gears.

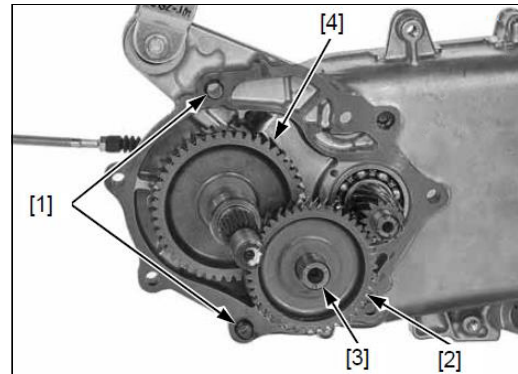

12. Allow transmission oil to drain from the crankcase and transmission case for **one minute** into the oil collection pan.



NEW

13. Using a funnel and a graduated cylinder (> 100 cc capacity), pour the collected oil into the cylinder allowing **one minute** of time for all oil to drain from the oil collection pan into the funnel and cylinder.

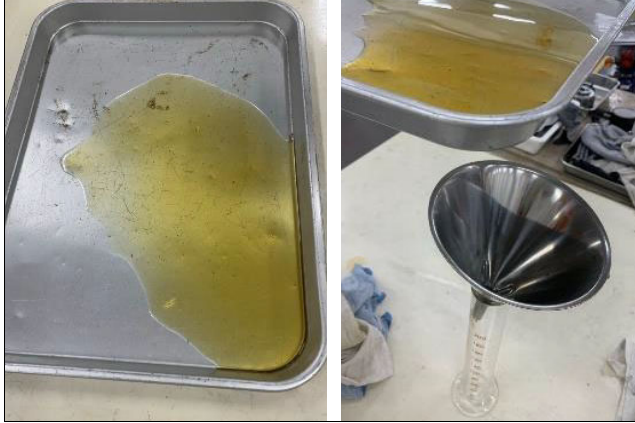

14. Place the graduated cylinder on a level surface and measure the oil level. Document your results for the final conclusion of the inspection.



15. Check the condition of the lowest bolt seating surface at the bottom of the left crankcase (circled in red).

If the lower bolt hole is no good (rough), it must be resurfaced using the BOLT HOLE RESURFACING procedure on page 9.

If you are unsure, resurface the bolt hole after reading the CONCLUSION information on the next page.

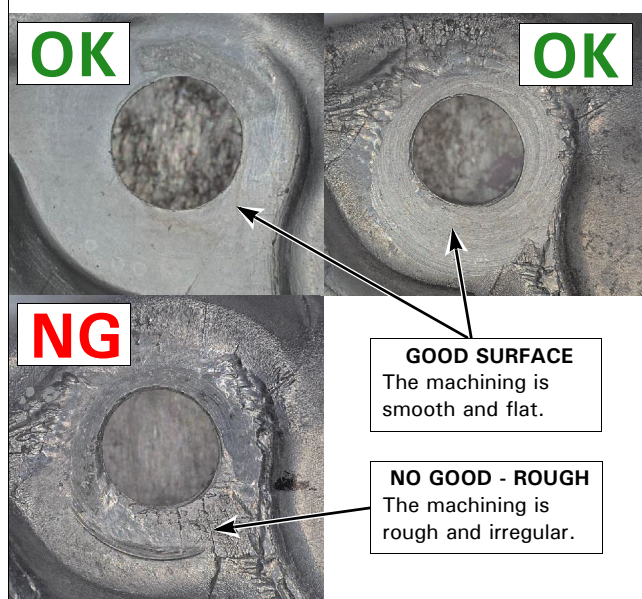
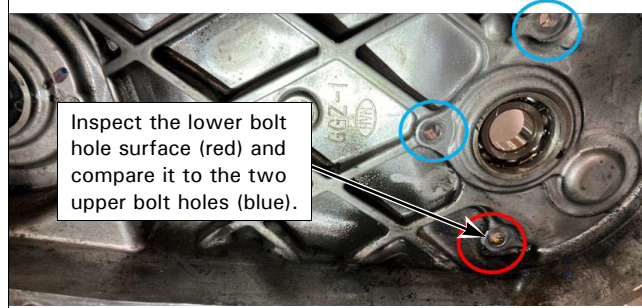

CONCLUSION:

Based on the results of the transmission oil volume measurement and condition of the lowest left crankcase bolt hole, determine which repair below applies to the affected unit.

Repair #1: If the transmission has **50 ~ 100 cc** of oil and the left crankcase bolt hole surface is correctly machined and passed inspection:

1. Order only the Inspection Kit (page 2).
2. Reassemble the unit following the REPAIR #1 and #2 REASSEMBLY PROCEDURE on page 10.

Repair #2: If the transmission has **50 ~ 100 cc** of oil in the case and the left crankcase bolt hole surface fails inspection:

1. Order only the Inspection Kit (page 2).
2. Resurface the left crankcase lower bolt hole using the BOLT HOLE RESURFACING procedure on page 9.
3. Reassemble the unit following the REPAIR #1 and #2 REASSEMBLY PROCEDURE on page 10.

Repair #3: If the transmission has **less than 50 cc** of oil in the case and the left crankcase bolt hole surface is correctly machined and passed inspection:

1. Order the Inspection Kit and Repair Kit (page 2). **Note:** The Repair Kit is under Techline control.
2. Reassemble the unit following the REPAIR #3 and #4 REASSEMBLY PROCEDURE on page 15.

Repair #4: If the transmission has **less than 50 cc** of oil in the case and the left crankcase bolt hole surface failed inspection:

1. Order the Inspection Kit and Repair Kit (page 2). **Note:** The Repair Kit is under Techline control.
2. Grind the left crankcase lower bolt hole using the BOLT HOLE RESURFACING procedure on page 9.
3. Reassemble the unit following the REPAIR #3 and #4 REASSEMBLY PROCEDURE on page 15.

BOLT HOLE RESURFACING

If the left crankcase bolt hole fails inspection, it requires resurfacing. Use the socket bolt and #80 grit sandpaper disc provided in the Inspection Kit to grind the bolt hole surface smooth using the following steps.

Do not use power tools, such as a drill, for this procedure. Only use hand tools.

1. Remove the double-sided tape from the washer-shaped sandpaper included in the Inspection Kit and affix it to the seat surface of the M6 socket bolt.

The sticky side of the sandpaper should face the socket bolt head and the rough grit side should toward the transmission case.

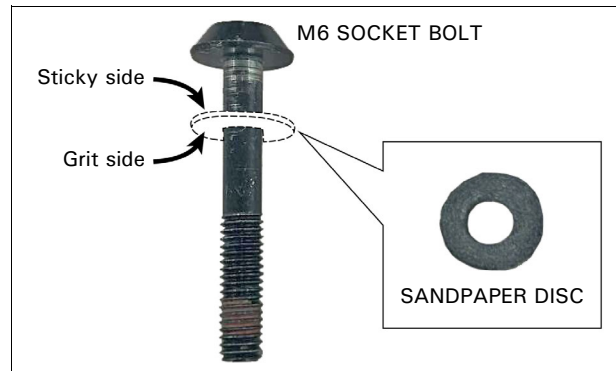

2. Insert the socket bolt into the relevant bolt hole and grind the seating surface smooth by turning the bolt right and left using a hex screwdriver or Allen socket (approx. 60 seconds or more). **Do not use a drill!**

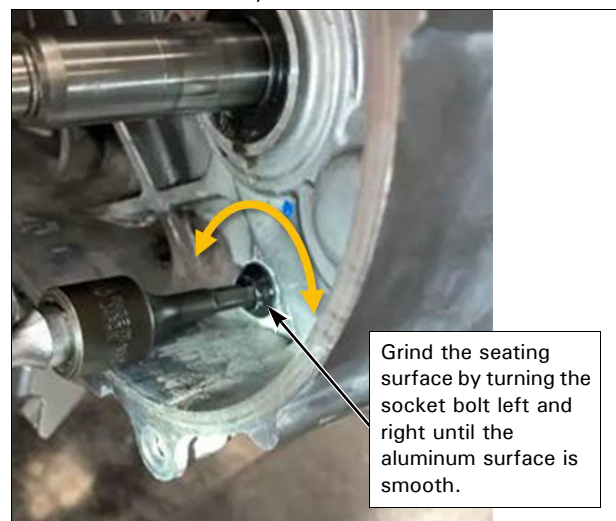

- Grind until the seat surface condition is similar to the photos below while checking the condition of the seat surface.

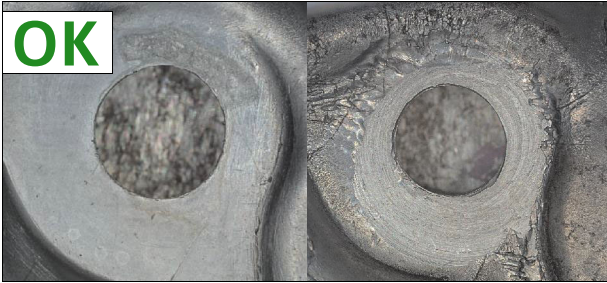

- Clean around the bolt seating surface using parts cleaner.

Note: When tightening the transmission case bolt after resurfacing, tighten the bolt to the appropriate torque, loosen the bolt, and then retighten the bolt.

REPAIR #1 AND #2 REASSEMBLY PROCEDURE

- Clean off the sealant from the left crankcase and the transmission case mating surfaces.

Clean off any remaining oil residue from the left crankcase and transmission case mating surfaces using parts cleaner.

- Apply engine oil to each transmission gear and each bearing sliding area of the final gear shaft [1].

Install the final gear shaft [1].

Install the countershaft [2] onto the counter gear [3] while aligning the countershaft splines with the counter gear splines and install them to the left crankcase.

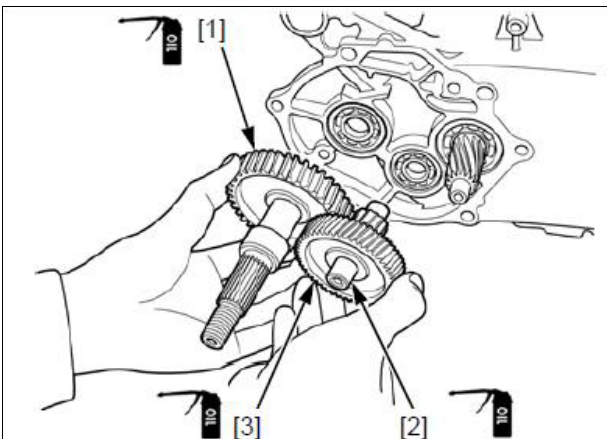

- Apply sealant (Hondabond 4 or equivalent) to the transmission case mating surface.

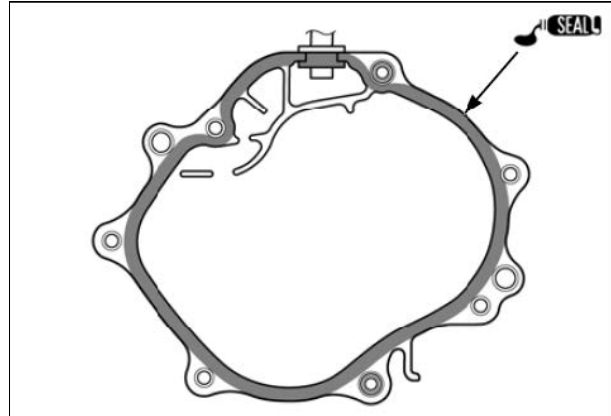

- Install the dowel pins [1].

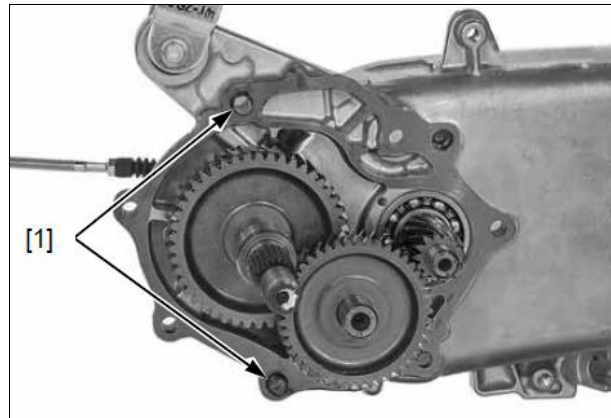

- Install the transmission case [1], then install and tighten the bolts [2] in a crisscross pattern in two or three steps.

IMPORTANT: When tightening the transmission case bolt [3] if it was resurfaced, tighten the bolt to specified torque, loosen the bolt, and then retighten the bolt again to the specified torque.

TORQUE: 12 N·m (1.2 kgf·m, 9 lbf·ft)

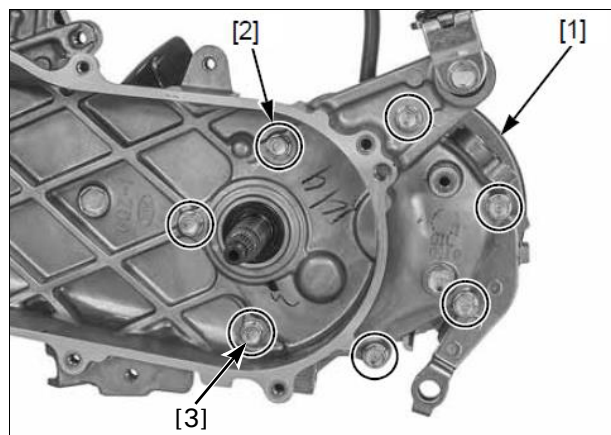

NEW

6. Install the rear brake cable [1] into the transmission case and tighten the adjusting nut.

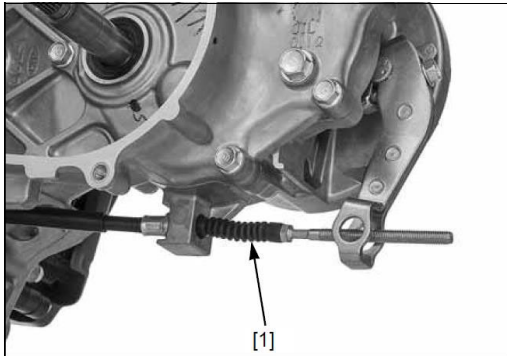

7. Install the brake shoes and shoe springs.

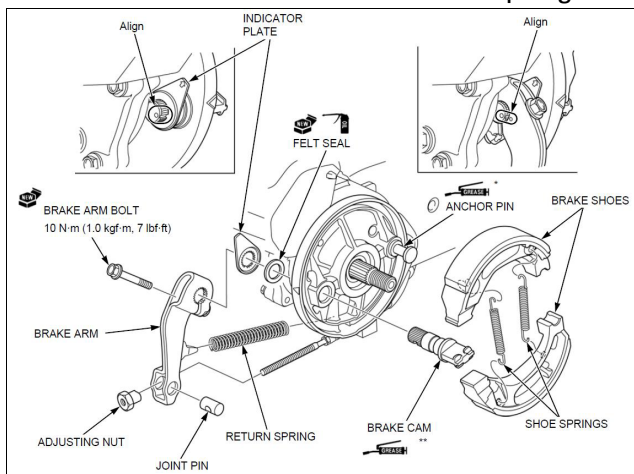

8. Install the VS Sensor [3].

Reconnect the VS sensor 3P (Black) connector [1].

Tighten the bolt [2] securely.

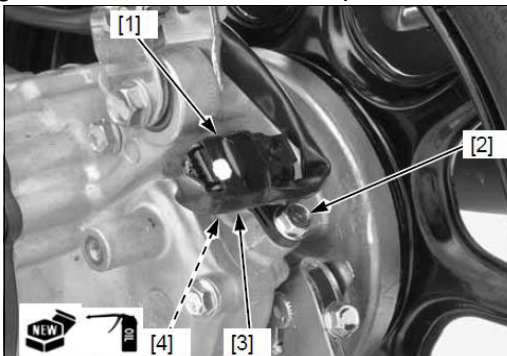

9. Install the VS Sensor Protector [2]:

Install the transmission case breather hose [3] and clip [1].

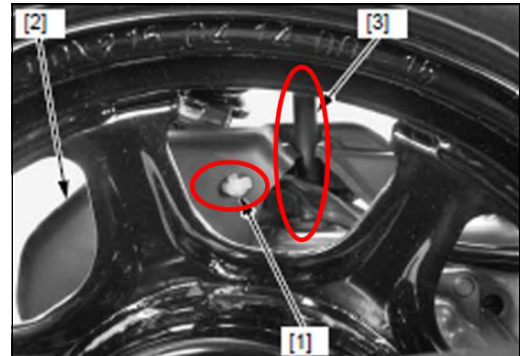

Reattach the wire band boss [2] to the sensor protector [3].

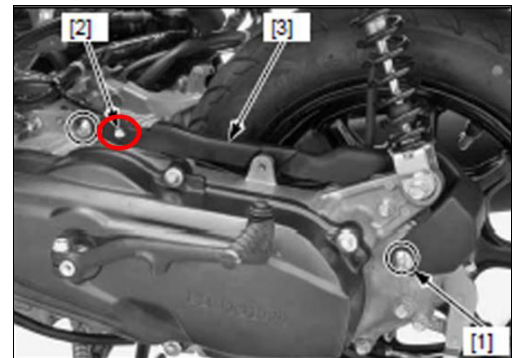

Reinstall the socket bolt onto the sensor protector and tighten to the specified torque.

TORQUE: 10 N·m (1.0 kgf·m, 7 lbf·ft)

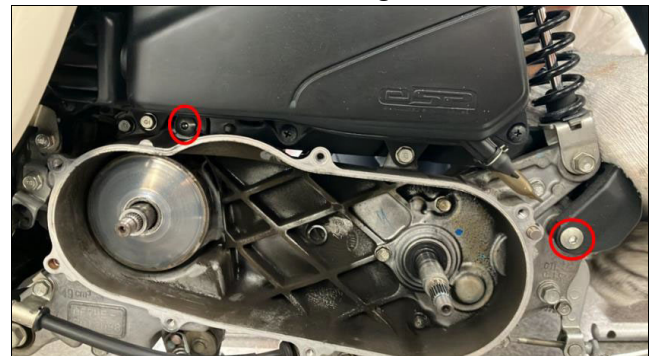

Reinstall the air cleaner case fixing bolt.

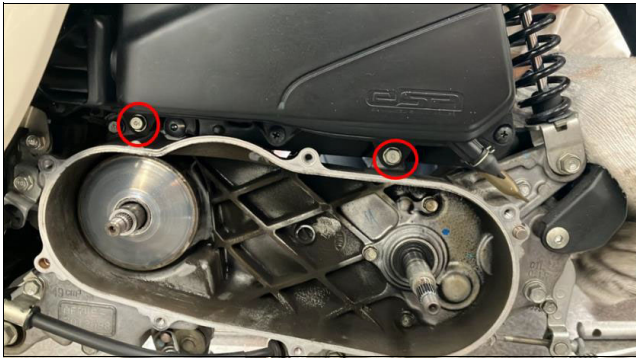

10. Reinstall the clutch and driven pulley:

Hold the clutch/driven pulley assembly [1] and compress the drive face spring by turning movable driven face [2] clockwise until it stops.

Set the drive belt [3] onto the pulley groove while holding the movable driven face.

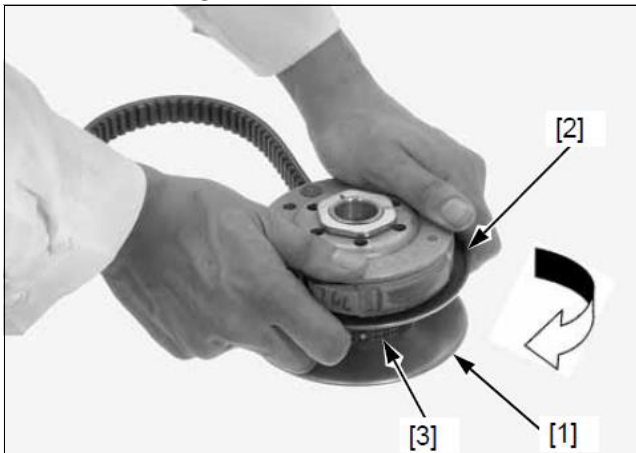

Install the clutch/driven pulley assembly [1] onto the drive shaft [2].

*Do not get grease on the drive shaft splines from the driven face inside.



Install the clutch outer [1] and clutch outer nut [2].

Hold the clutch outer with the special tool and tighten the clutch outer nut to the specified torque.

TOOL:

[3] Flywheel holder 07725-0040001

TORQUE: 39 N·m (4.0 kgf·m, 29 lbf·ft)

Install the drive pulley face.

*Use the special tool when tightening the lock nut. Holding the rear wheel or rear brake will damage the final reduction system.

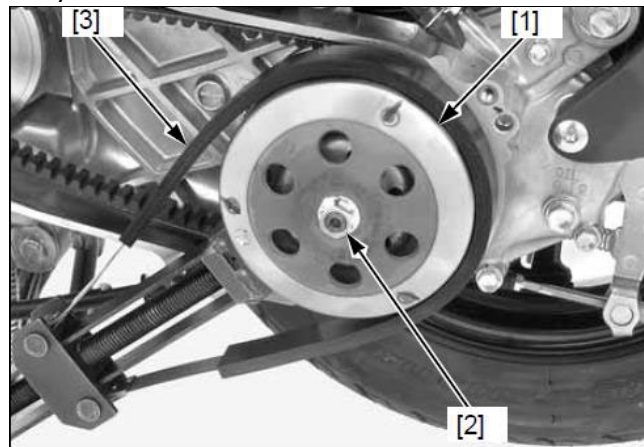

11. Reinstall the drive belt and drive pulley:

Clean any oil and grease from the drive face and drive belt.

Install the movable drive face assembly [1] onto the crankshaft while holding the ramp plate [2] and drive face boss [3].

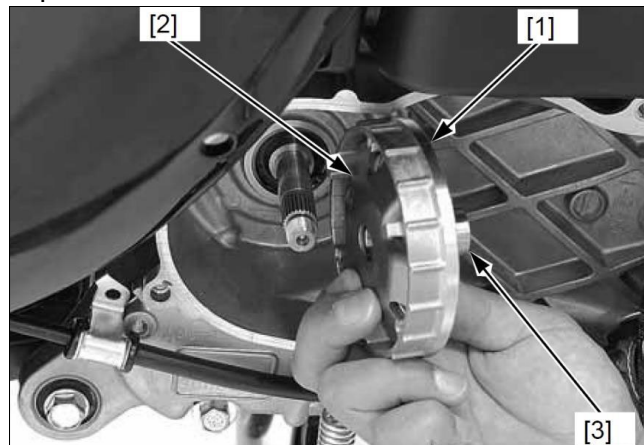

Set the drive belt [1] and install the drive pulley face [2] while aligning its splines with crankshaft splines.

Make sure that the drive pulley face is fully seated on the drive face boss [3].

Apply engine oil to the left crankshaft threads.

* Be careful not to damage the spline.

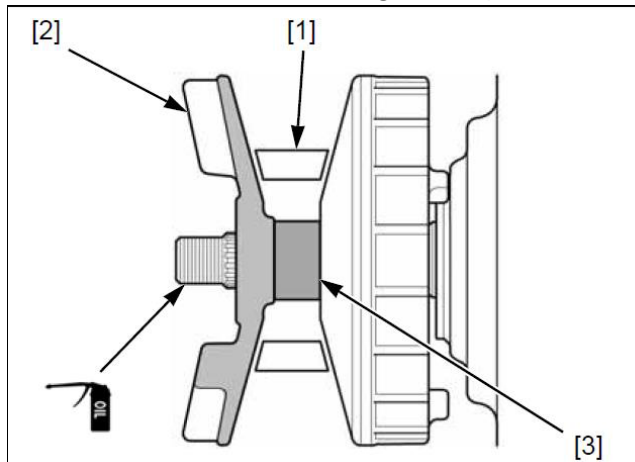

Install the ratchet plate [1] while aligning its splines with crankshaft splines.

Install the washer [2].

Apply engine oil to the drive pulley face nut [3] threads and seating surface.

Hold the drive pulley face with the special tool and tighten the nut to the specified torque.

TOOL:

[4] Clutch center holder 07725-0030000

TORQUE: 32 N·m (3.3 kgf·m, 24 lbf·ft)

Install the removed parts in the reverse order of removal.

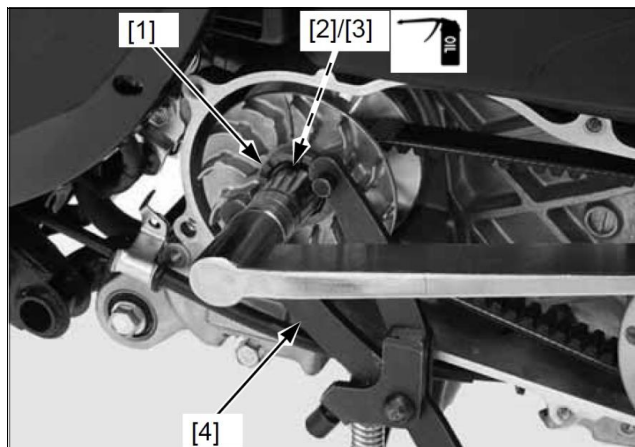

12. Reinstall the left crankcase cover:

Clean the crankcase and crankcase cover mating surfaces.

Reinstall the two dowel pins [1] and install a **new** cover gasket [2].

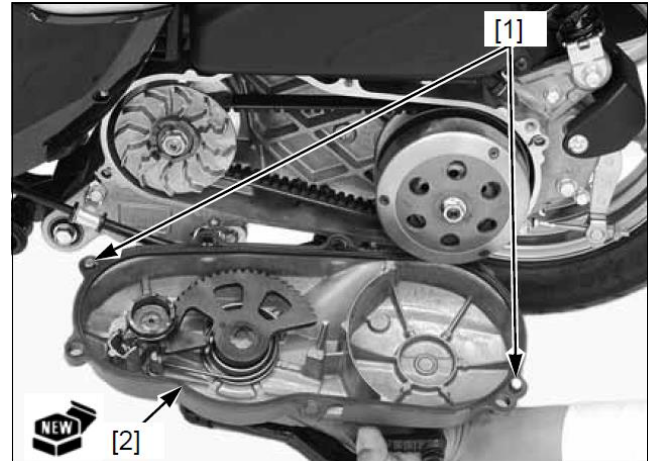

Reinstall the left crankcase cover [3], six special bolts [1] and mount rubbers [2]. Tighten the bolts to the specified torque.

TORQUE: 10 N·m (1.0 kgf·m, 7 lbf·ft)

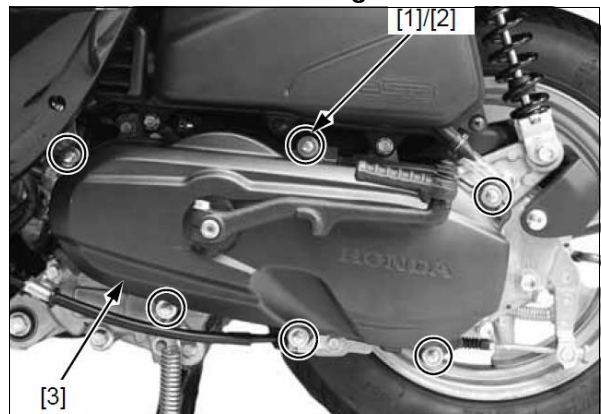

Reinstall the following:

- Bolt [1] and rear brake cable clamp [2]
- Bolt [3] and rear brake cable holder [4]
- Rear brake cable [5]

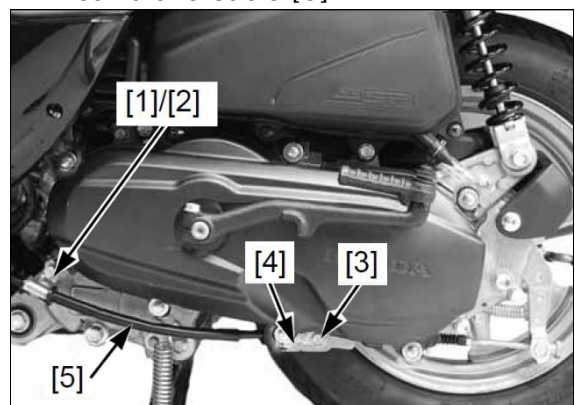

13. Fill the transmission case with fresh oil:

Support the scooter with its centerstand on level ground.

Remove the oil check bolt [1] and sealing washer [2].

Fill the transmission case with the recommended oil up to the correct level [3].

Pro Honda HP4M (with molybdenum additives) 4-stroke oil or an equivalent API service classification: SJ or higher

Viscosity: SAE 10W-30

Install the oil check bolt with a **new** sealing washer and tighten it to the specified torque.

TORQUE: 13 N·m (1.3 kgf·m, 10 lbf·ft)

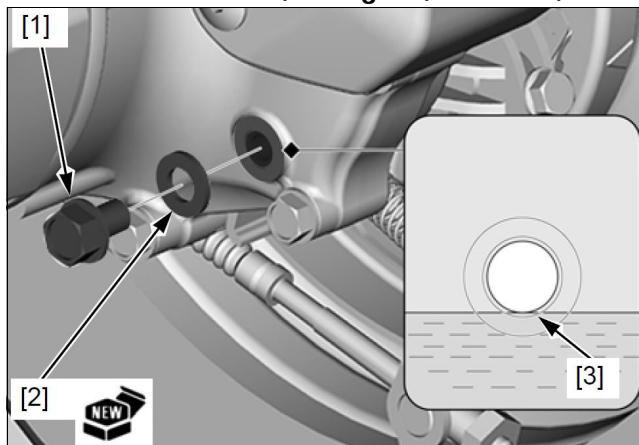

14. Install the rear wheel [3] onto the final gear shaft, aligning its splines with the final gear shaft splines. Apply engine oil to the rear axle nut threads and seating surface [1]. Tighten the axle nut [2] to the specified torque.

TORQUE: 118 N·m (12.0 kgf·m, 87 lbf·ft)



15. Reinstall the muffler [3]:

Install a **new** exhaust pipe gasket [4] onto the exhaust pipe flange.

Position the muffler so its exhaust pipe flange is set on the exhaust pipe stud bolts, then install the joint nuts.

Tighten the two joint nuts [1] to the specified torque.

TORQUE: 10 N·m (1.0 kgf·m, 7 lbf·ft)

Tighten the muffler bracket bolts [2] to the specified torque.

TORQUE: 35 N·m (3.6 kgf·m, 26 lbf·ft)

After installation, start the engine and check the exhaust system for leaks.

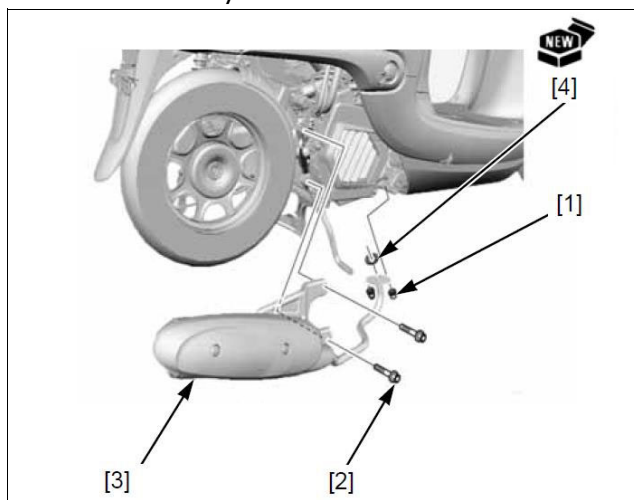

16. The repair is complete. Perform a final operation check to ensure the scooter functions properly.

17. Continue to the **WARRANTY CLAIM INFORMATION** on page 3.

**REPAIR #3 AND #4
REASSEMBLY PROCEDURE**

1. Clean off the sealant from the left crankcase surface where transmission case mates.

Clean off any remaining oil residue from the left crankcase mating surface using parts cleaner.

2. Remove the countershaft bearing [1] and final gear shaft bearing [2] using the special tools. Be careful not to damage the transmission case mating surface.

TOOLS:

Countershaft bearing:

Bearing remover, 12 mm 07936-166010A
Remover weight 07936-371020A
Remover handle 07936-3710100

Final gear shaft bearing:

[3] Bearing remover, 15 mm 07936-KC10500
[5] Remover weight 07936-371020A
[4] Remover handle 07936-3710100

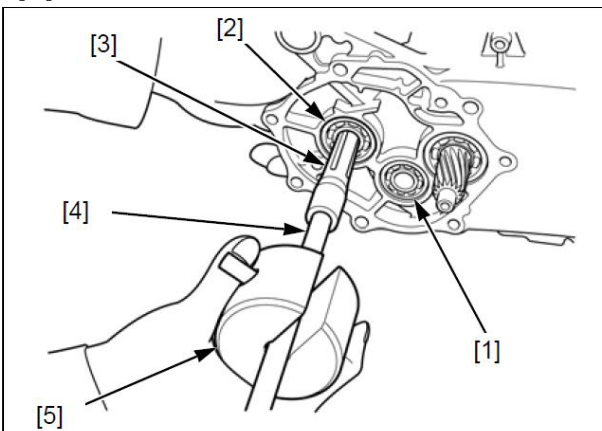

3. Install the **new** countershaft bearing [1] and final gear shaft bearing [2] into the left crankcase.

Drive the bearings into the left crankcase squarely with the marked sides facing up until fully seated, using the special tools.

TOOLS:

Countershaft bearing:

Driver 07749-0010000
Attachment, 32 x 35 mm 07746-0010100
Pilot, 12 mm 07746-0040200

Final gear shaft bearing:

[3] Driver 07749-0010000
[4] Attachment, 32 x 35 mm 07746-0010100
[5] Pilot, 15 mm 07746-0040300

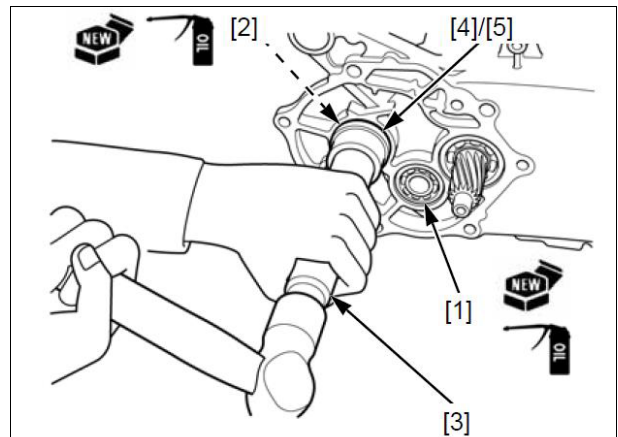

4. Remove the driveshaft [1] using the special tool.

TOOL:

[2] Case puller 07SMC-0010001

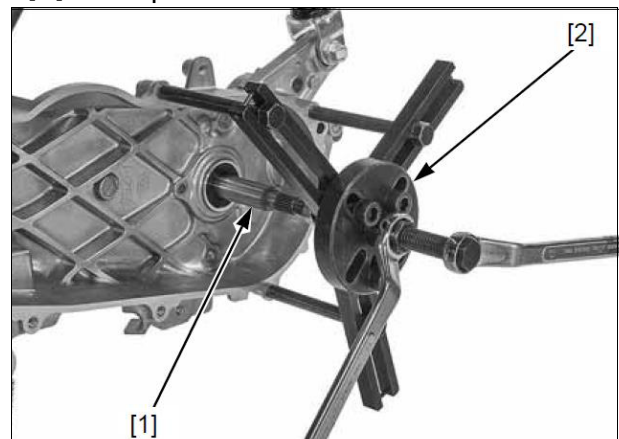

If the drive shaft bearing remains on the drive shaft, continue to step 5.

If the drive shaft bearing [3] remains in the left crankcase, drive it out from the left-hand side.



5. Remove the drive shaft oil seal [1].

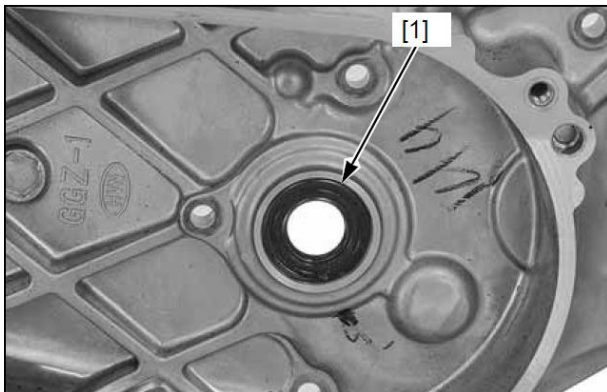

6. Install a **new** drive shaft bearing [1] into the left crankcase:

Apply engine oil to the bearing cavity.

Drive the bearing [1] into the left crankcase squarely until it is fully seated, using the special tools. Be sure the bearing is set with its marked side facing up.

TOOLS:

[2] Driver 07749-0010000

[3] Attachment, 37 x 40 mm 07746-0010200

[4] Pilot, 17 mm 07746-0040400

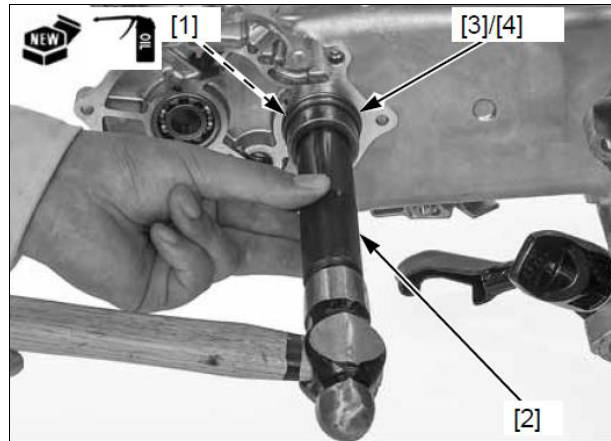

7. Install a **new** drive shaft [1] into the bearing [2].

Pull the drive shaft into the bearing until it is fully seated, using the special tools.

TOOLS:

[3] Assembly collar 07965-GM00100

[4] Assembly shaft 07965-GM00300

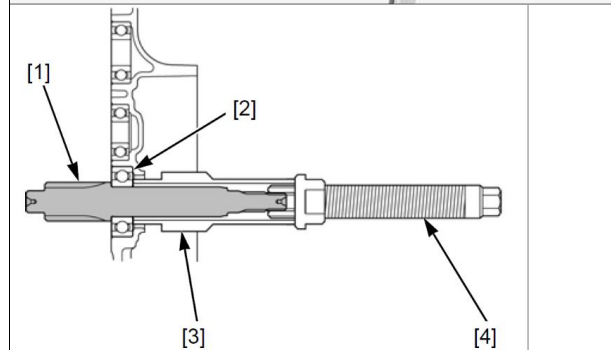
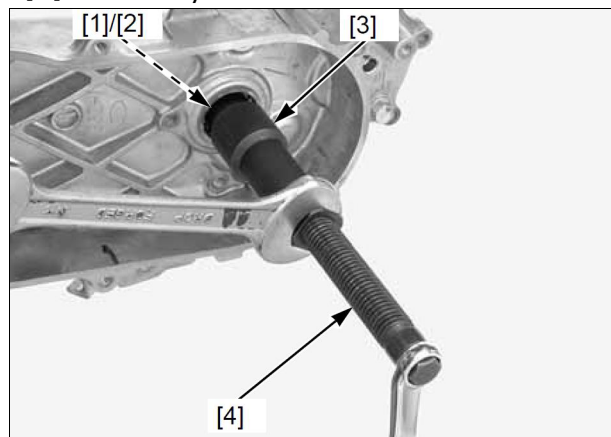

8. Install a **new** drive shaft oil seal:

Apply engine oil to the drive shaft oil seal [1] lip.

Install the drive shaft oil seal so that the depth from the left crankcase surface is 0.7 - 1.2 mm (0.03 - 0.05 in), using the special tools.

TOOLS:

[2] Assembly shaft 07965-GM00300

[3] Assembly collar 07965-GC70100

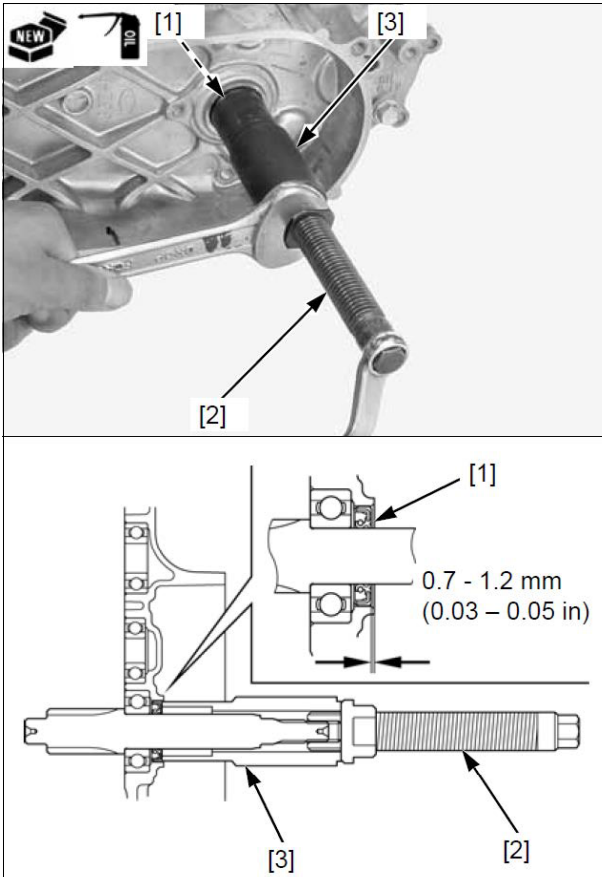

9. Install **new** drive shaft and countershaft bearings into the **new** transmission case:

Apply engine oil to the drive shaft bearing and countershaft bearing outer races and their case cavities.

Drive the bearings into the transmission case squarely until they are fully seated, using the special tools. Be sure the bearings are set with their marked sides facing up.

TOOLS:

[3] Driver 07749-0010000

[4] Attachment, 32 x 35 mm 07746-0010100

[5] Pilot, 12 mm 07746-0040200

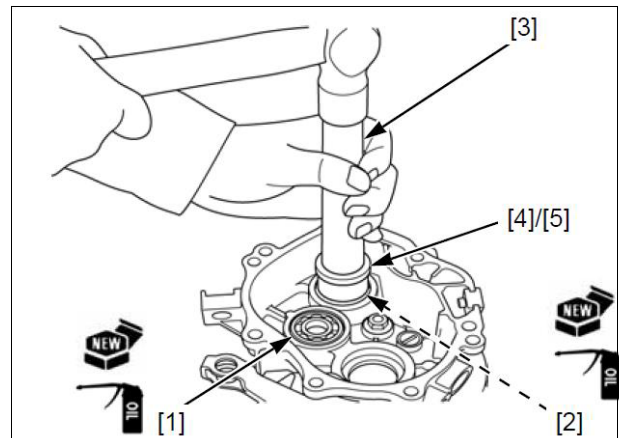

10. Install a **new** final shaft bearing into the **new** transmission case:

Apply engine oil to the final shaft bearing and its case cavity.

Drive the final gear shaft bearing [1] into the transmission case squarely until it is fully seated, using the special tools. Be sure the bearing is set with its marked side facing up.

TOOLS:

[2] Driver 07749-0010000

[3] Attachment, 37 x 40 mm 07746-0010200

[4] Pilot, 17 mm 07746-0040400

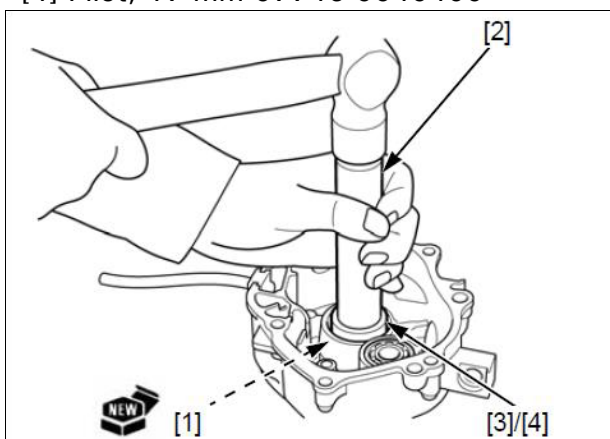

11. Apply engine oil to a **new** final gear shaft oil seal [1] lip.

Install the **new** oil seal with the flat side facing the rear wheel side so that the depth from the transmission case surface is 0.7 mm using the special tools. **Do not insert the oil seal too far.**

TOOLS:

[2] Driver 07749-0010000

[3] Attachment, 37 x 40 mm 07746-0010200

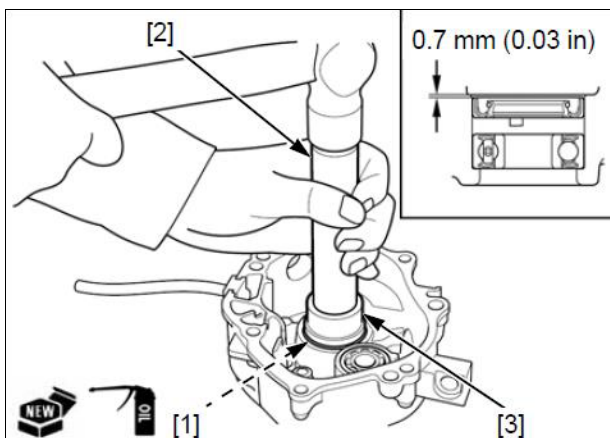

12. Apply engine oil to each **new** transmission gear and each bearing sliding area of the final gear shaft [1].

Install the **new** final gear shaft [1].

Install the **new** countershaft [2] onto the **new** counter gear [3] while aligning the countershaft splines with the counter gear splines and install them to the left crankcase.

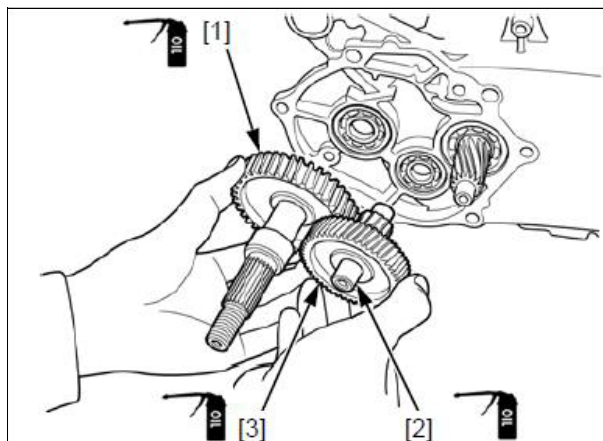

13. Apply sealant (Hondabond 4 or equivalent) to the transmission case mating surface.

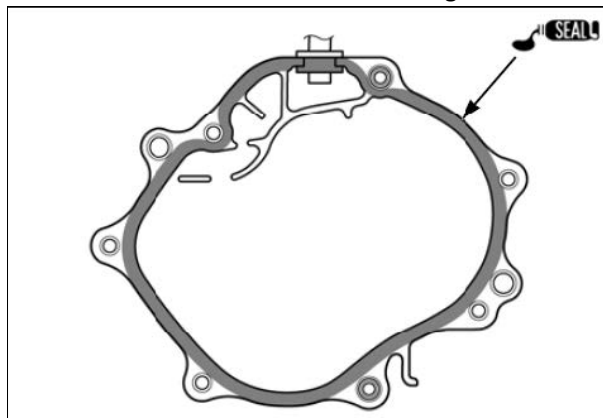

14. Install the dowel pins [1].

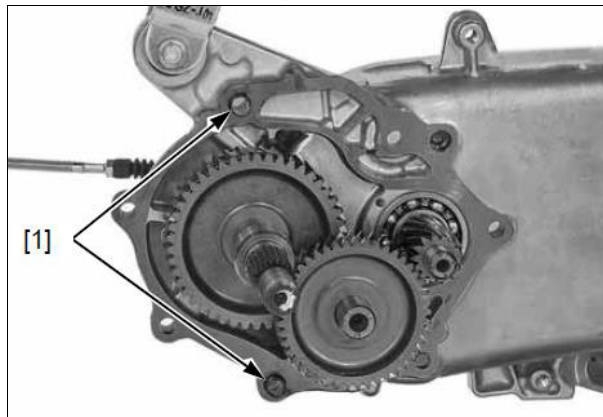

15. Install the **new** transmission case [1], then install and tighten the bolts [2] in a crisscross pattern in two or three steps.

NEW

IMPORTANT: When tightening the transmission bolt (circled in red) after resurfacing, tighten the bolt to specified torque, loosen the bolt, and then retighten the bolt again to the specified torque.

TORQUE: 12 N·m (1.2 kgf·m, 9 lbf·ft)

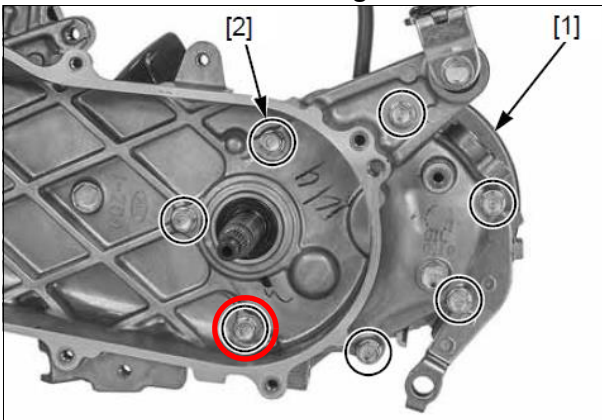

16. Remove the following brake parts from the original transmission case and swap them into the **new** transmission case:

- Brake shoes and shoe springs
- Brake Arm
- Brake Cam
- Return spring
- Adjusting nut
- Indicator plate

Replace the brake arm bolt with the **new** brake arm bolt from the Repair Kit.

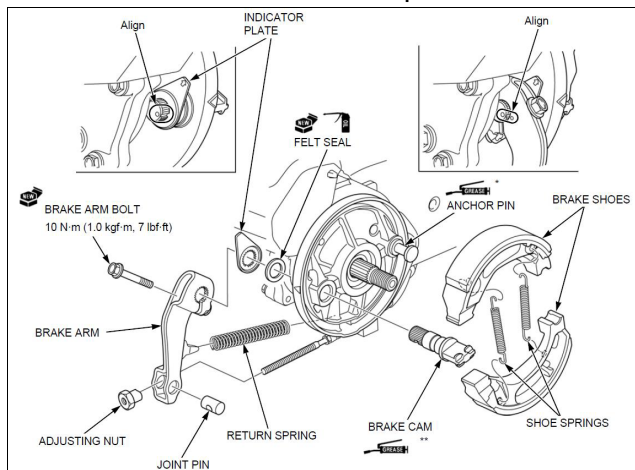

17. Install the rear brake cable [1] into the transmission case and tighten the adjusting nut.

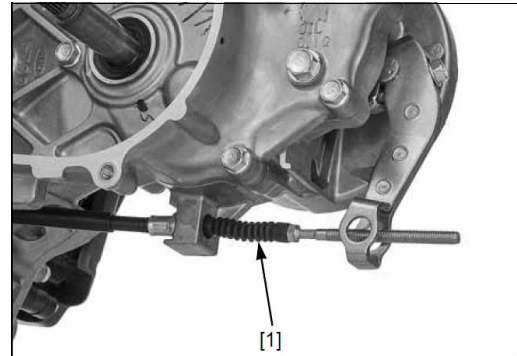

18. Install the VS Sensor [3] using a **new** O-ring coated in engine oil.

Reconnect the VS sensor 3P (Black) connector [1].

Tighten the bolt [2] securely.

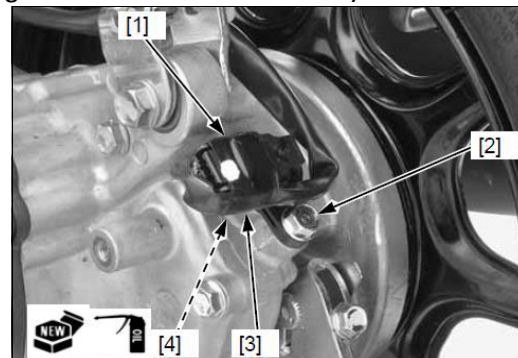

19. Install the VS Sensor Protector [2]:

Install the transmission case breather hose [3] and clip [1].

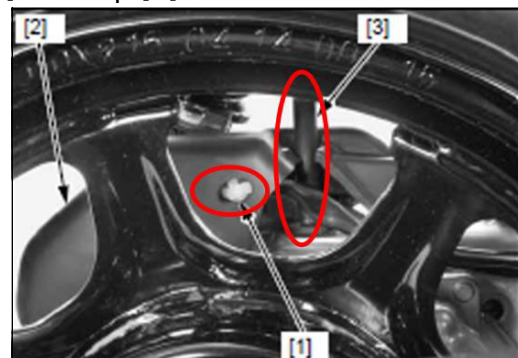

Reattach the wire band boss [2] to the sensor protector [3].

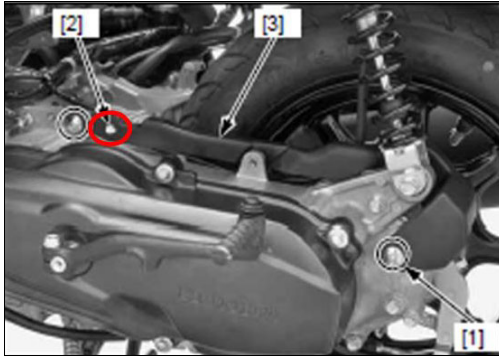

Reinstall the socket bolt onto the sensor protector and tighten to the specified torque.

TORQUE: 10 N·m (1.0 kgf·m, 7 lbf·ft)



Reinstall the air cleaner case fixing bolt.

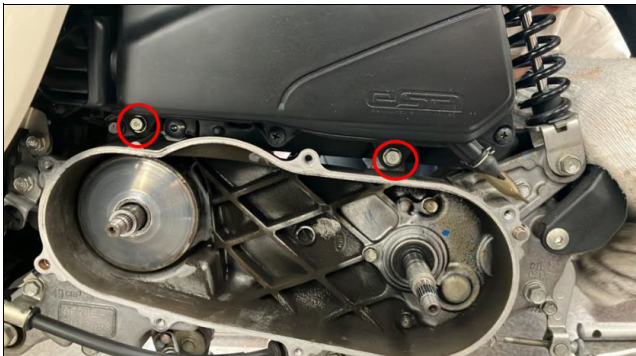

20. Reinstall the clutch and driven pulley:

Hold the clutch/driven pulley assembly [1] and compress the drive face spring by turning movable driven face [2] clockwise until it stops.

Set the drive belt [3] onto the pulley groove while holding the movable driven face.

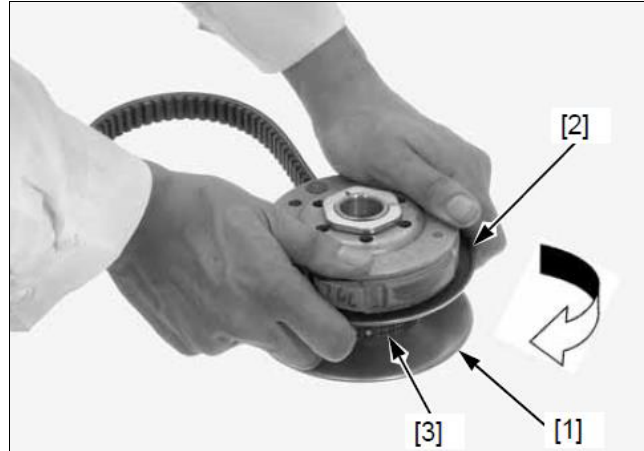

Install the clutch/driven pulley assembly [1] onto the drive shaft [2].

*Do not get grease on the drive shaft splines from the driven face inside.

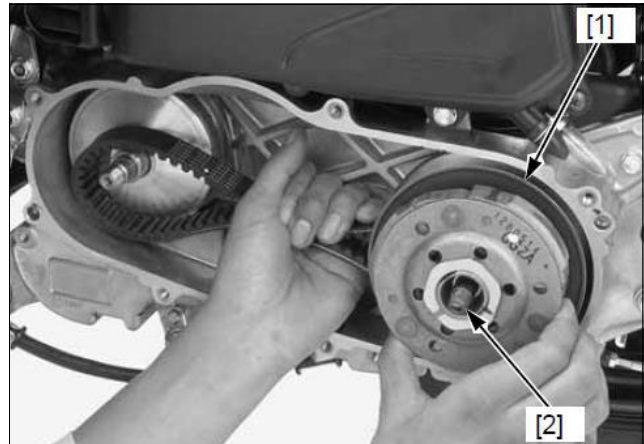

Install the clutch outer [1] and clutch outer nut [2].

Hold the clutch outer with the special tool and tighten the clutch outer nut to the specified torque.

TOOL:

[3] Flywheel holder 07725-0040001

TORQUE: 39 N·m (4.0 kgf·m, 29 lbf·ft)

Install the drive pulley face.

*Use the special tool when tightening the lock nut. Holding the rear wheel or rear brake will damage the final reduction system.

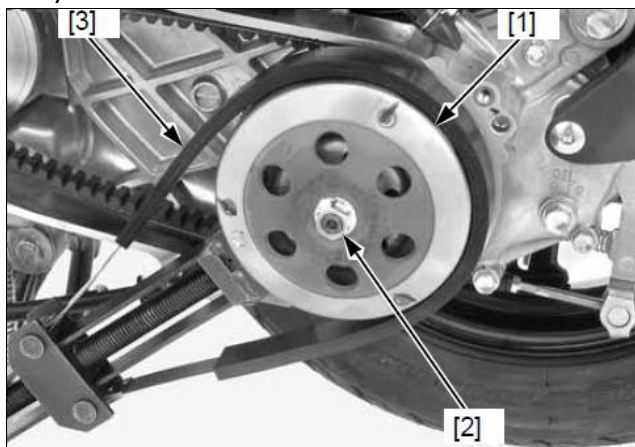

21. Reinstall the drive belt and drive pulley:

Clean any oil and grease from the drive face and drive belt.

Install the movable drive face assembly [1] onto the crankshaft while holding the ramp plate [2] and drive face boss [3].

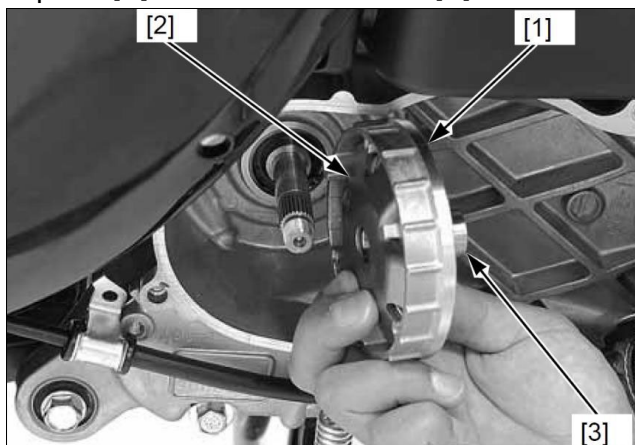

Set the drive belt [1] and install the drive pulley face [2] while aligning its splines with crankshaft splines.

Make sure that the drive pulley face is fully seated on the drive face boss [3].

Apply engine oil to the left crankshaft threads.

* Be careful not to damage the spline.

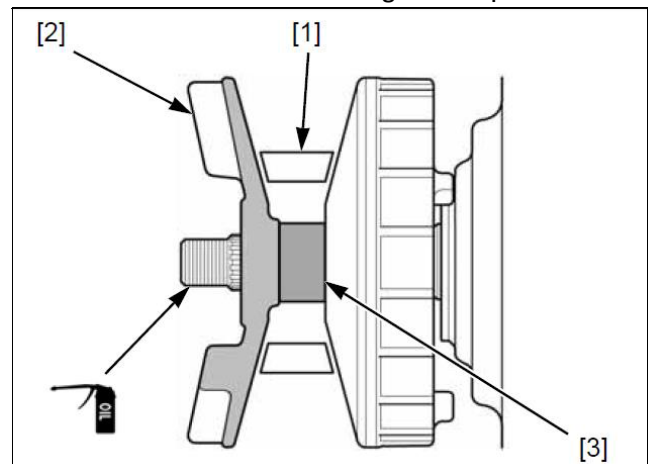

Install the ratchet plate [1] while aligning its splines with crankshaft splines.

Install the washer [2].

Apply engine oil to the drive pulley face nut [3] threads and seating surface.

Hold the drive pulley face with the special tool and tighten the nut to the specified torque.

TOOL:

[4] Clutch center holder 07725-0030000

TORQUE: 32 N·m (3.3 kgf·m, 24 lbf·ft)

Install the removed parts in the reverse order of removal.

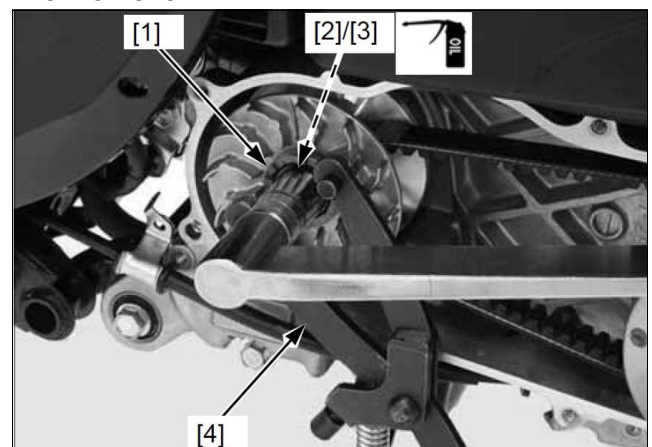

22. Reinstall the left crankcase cover:

Clean the crankcase and crankcase cover mating surfaces.

Reinstall the two dowel pins [1] and install a new sealing rubber [2].

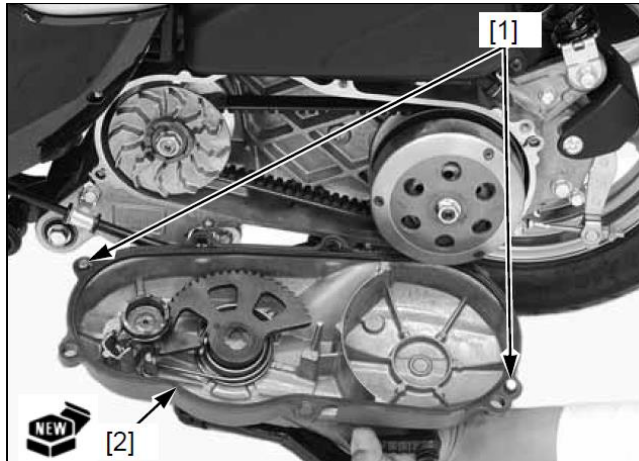

Reinstall the left crankcase cover [3], six special bolts [1], and mount rubbers [2]. Tighten the bolts to the specified torque.

TORQUE: 10 N·m (1.0 kgf·m, 7 lbf·ft)

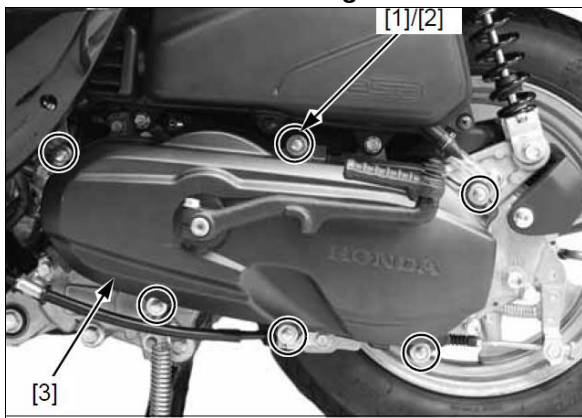

Reinstall the following:

- Bolt [1] and rear brake cable clamp [2]
- Bolt [3] and rear brake cable holder [4]
- Rear brake cable [5]

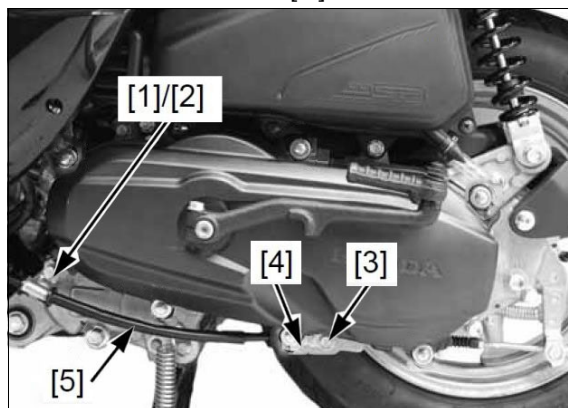

23. Fill the transmission case with fresh oil:

Support the scooter with its centerstand on level ground.

Remove the oil check bolt [1] and sealing washer [2].

Fill the transmission case with the recommended oil up to the correct level [3].

Oil Fill Amount: 0.1 L (100 cc, 3.4 fl. oz.)

Pro Honda HP4M (with molybdenum additives) 4-stroke oil or an equivalent API service classification: SJ or higher

Viscosity: SAE 10W-30

Install the oil check bolt with a new sealing washer and tighten it to the specified torque.

TORQUE: 13 N·m (1.3 kgf·m, 10 lbf·ft)

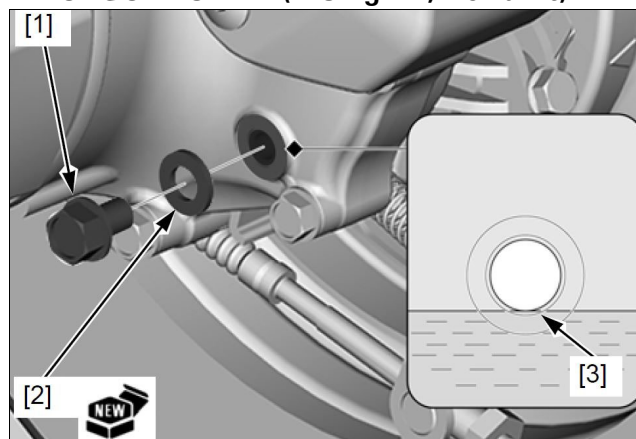

24. Install the rear wheel [3] onto the final gear shaft, aligning its splines with the final gear shaft splines. Apply engine oil to the rear axle nut threads and seating surface [1]. Tighten the axle nut [2] to the specified torque.

TORQUE: 118 N·m (12.0 kgf·m, 87 lbf·ft)



25. Reinstall the muffler [3]:

Install a new exhaust pipe gasket [4] onto the exhaust pipe flange.

Position the muffler so its exhaust pipe flange is set on the exhaust pipe stud bolts, then install the joint nuts.

Tighten the two joint nuts [1] to the specified torque.

TORQUE: 10 N·m (1.0 kgf·m, 7 lbf·ft)

Tighten the muffler bracket bolts [2] to the specified torque.

TORQUE: 35 N·m (3.6 kgf·m, 26 lbf·ft)

After installation, start the engine and check the exhaust system for leaks.

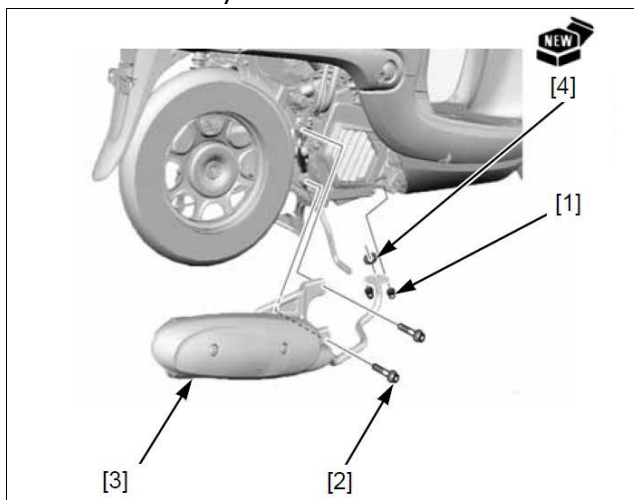

26. The repair is complete. Perform a final operation check to ensure the scooter functions properly.

Continue to the WARRANTY CLAIM INFORMATION on page 3.