



Recall Service Bulletin



**Recall Service Bulletin
RSB24-230-001**

DATE: 11/13/2024

APPLIES TO: This service bulletin applies to certain model year 2024-2025 Metro Star and FC-94, and 2025 Gladiator and KME Panther model emergency response chassis cabs built between August 2024 and October 2024.

NHTSA/TC Id: 24V799/2024-639

CONDITION: Cab Tilt Cylinder may be lacking an internal mechanical stop and may overextend.

CORRECTION: Inspect and replace non-conforming cylinders

LABOR ALLOCATION: Inspection: 0.5 hour
Replacement: 2.0 hours

CLASSIFICATION: V3

Parts

<u>QTY</u>	<u>Part Number</u>	<u>Description</u>
2	1180-EE1-011	Cab tilt cylinders

GENERAL INSTRUCTIONS:

Thoroughly review entire service bulletin before starting work. If there are questions or concerns with steps defined in this service bulletin, contact Spartan Fire, LLC. Customer & Product Support Group.

All applicable industry safety standards must be followed when performing work identified in this procedure.

Service Bulletins are intended for use by Professional Technicians only. They are written to guide Professional Technicians in performing service to vehicles of specific nature in conjunction with industry standards. Professional Technicians should be appropriately trained on industry standards and have the tools and equipment to perform procedures safely and properly.



Recall Service Bulletin



Recall Service Bulletin
RSB24-230-001

Inspection Instructions

- 1) Ensure cab is in the lowered and in the cradled position with the park brake set.
- 2) Go under the front of the truck and inspect both cab tilt cylinders located in the front section of the cab.
- 3) Take clear pictures of each of the cab tilt cylinders showing the following:
 - a. A picture of the upper portion of the cylinder at the gland nut where the piston extends from the cylinder barrel
 - b. A picture showing the part number and serial number that is etched/engraved into the barrel of the cylinder. *(See Figures below for examples)*
- 4) Email last 8 digits of the VIN number along with the photos taken in step 3 to andy.haigh@spartanmotors.com. This step is critical to ensure proper direction is taken.
- 5) If cylinder is non-conforming, then replacement cylinders will be sent at no charge from Spartan Fire. Do not purchase cylinders for this repair.
- 6) If cylinder is conforming, then no further action is needed after photos have been emailed.

Non-conforming Cab Tilt Cylinder

- The cylinder gland nut has external threads and threads internally into the barrel.



Service Bulletins are intended for use by Professional Technicians only. They are written to guide Professional Technicians in performing service to vehicles of specific nature in conjunction with industry standards. Professional Technicians should be appropriately trained on industry standards and have the tools and equipment to perform procedures safely and properly.



Recall Service Bulletin



Recall Service Bulletin RSB24-230-001

- Part Number and Serial Number are laser dot etched into the barrel.



Conforming Cab Tilt Cylinder

- Cylinder gland nut threads externally over the cylinder barrel.
- Part number and serial number are engraved in the cylinder barrel.



Service Bulletins are intended for use by Professional Technicians only. They are written to guide Professional Technicians in performing service to vehicles of specific nature in conjunction with industry standards. Professional Technicians should be appropriately trained on industry standards and have the tools and equipment to perform procedures safely and properly.



Recall Service Bulletin



Recall Service Bulletin
RSB24-230-001

Replacement Instructions

- 1) Ensure park brake is set.
- 2) With Master switch on, ignition off, raise cab only to the point that the yellow safety bar engages on the cylinder rod.
- 3) Remove radiator stay rod lower bolts and move stay rods out of the way. *See Figure 4.1*

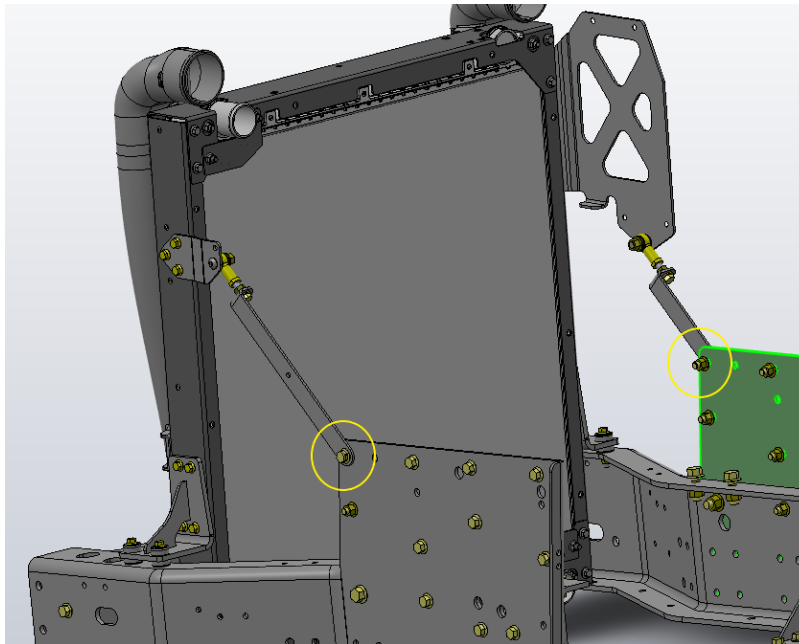

Figure 4.1

- 4) Lower cab and ensure it is down completely, and the light is off in the cab tilt pendent.
- 5) With drain pan in place, disconnect hydraulic hoses from the bottom of the cab tilt cylinders. *(A cap can be made to plug the line to prevent fluid draining from the hose.)*
- 6) Remove lower cab tilt cylinder pins by first removing the cotter-pins and the flat washers. *See Figure 5.1*

Service Bulletins are intended for use by Professional Technicians only. They are written to guide Professional Technicians in performing service to vehicles of specific nature in conjunction with industry standards. Professional Technicians should be appropriately trained on industry standards and have the tools and equipment to perform procedures safely and properly.



Recall Service Bulletin



Recall Service Bulletin
RSB24-230-001

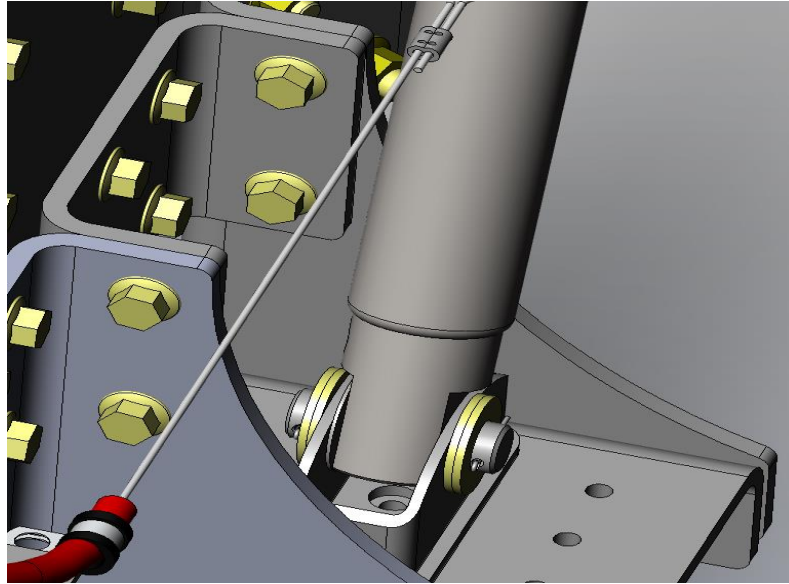

Figure 5.1

- 7) Remove the lower pins and note the number of washers (flat and belleville) that are located between mount and cylinder base. They will need to be reinstalled with the new cylinders.
See Figure 5.2

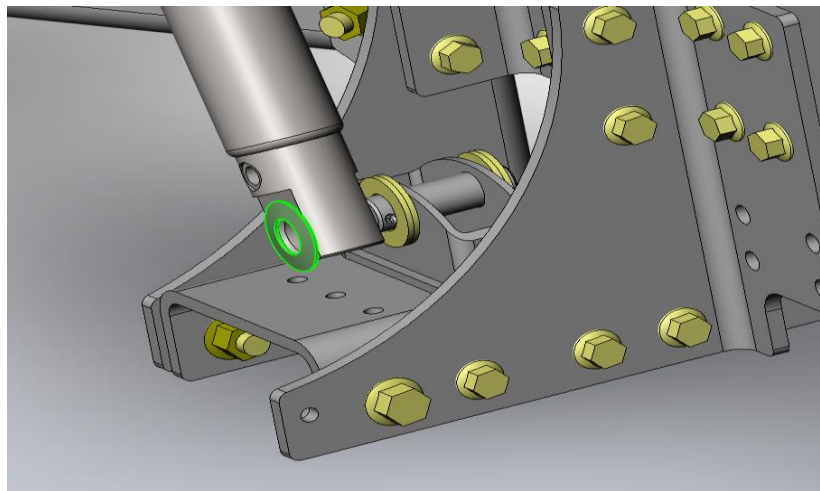

Figure 5.2

Service Bulletins are intended for use by Professional Technicians only. They are written to guide Professional Technicians in performing service to vehicles of specific nature in conjunction with industry standards. Professional Technicians should be appropriately trained on industry standards and have the tools and equipment to perform procedures safely and properly.



Recall Service Bulletin



Recall Service Bulletin RSB24-230-001

- 8) Remove the upper cylinder pin cotter-pins and outer washers. *See Figure 6.1*

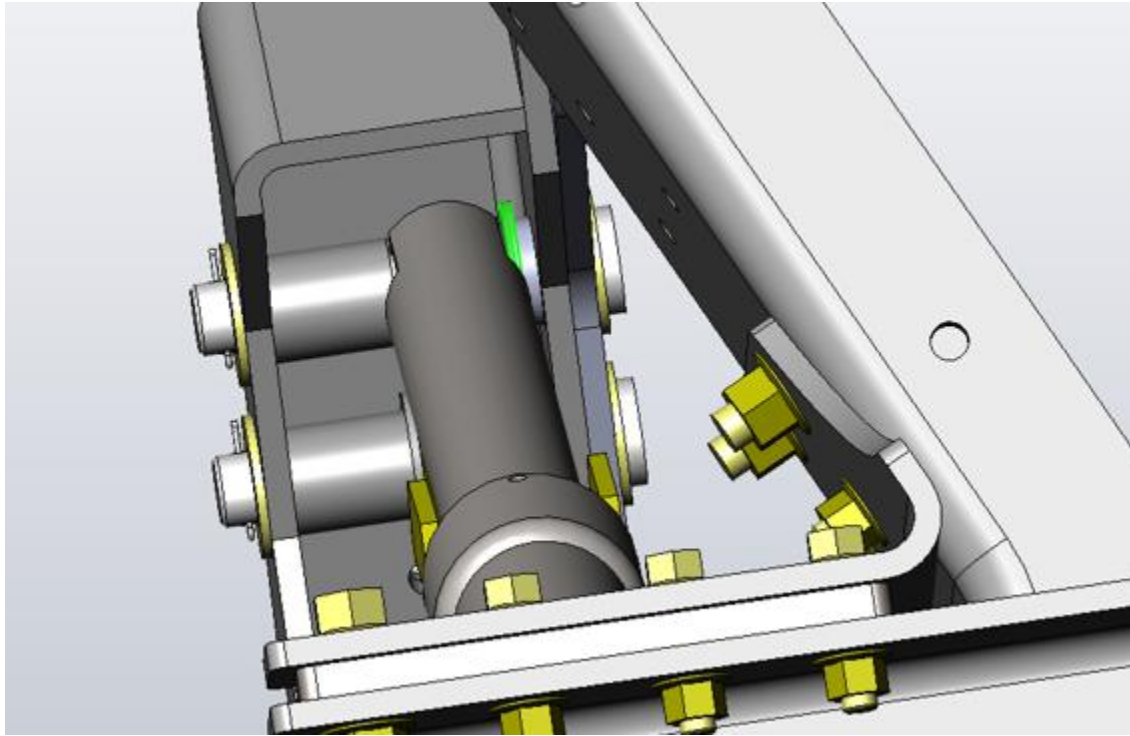

Figure 6.1

- 9) While supporting the bottom of the cylinder with a prybar or an alignment punch through the pin hole, lift cylinder and move the upper pin out of the upper cylinder hole. *(Inward movement of pin might be restricted by recirculation shield. Shield may need to be removed to permit adequate movement of pin).*
- 10) Remove the cab tilt cylinder by lifting the cylinder higher into the upper mount pocket. This allows for the bottom of the cylinder to then be moved rearward and out of the lower mount pocket.
- 11) Once cylinder is out of the chassis, remove the velocity fuse fitting at the base of the cylinder. This will be installed on the new cylinders.

Service Bulletins are intended for use by Professional Technicians only. They are written to guide Professional Technicians in performing service to vehicles of specific nature in conjunction with industry standards. Professional Technicians should be appropriately trained on industry standards and have the tools and equipment to perform procedures safely and properly.



Recall Service Bulletin



Recall Service Bulletin
RSB24-230-001

12) Install the velocity fuse fitting into the new cylinder. *See Figure 7.1*

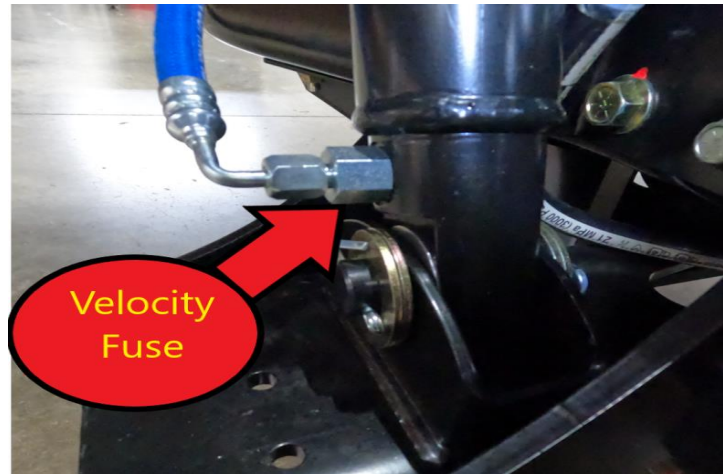

Figure 7.1

- 13) Install the new cylinder into the mounts.
- 14) Insert Belleville and flat washers between the cylinder base and the mount to prevent cylinder mount clunking.
- 15) Install lower and upper cab tilt cylinder pins, washers, and cotter pins. Ensure cotter pin split ends are separated from each other and wrap around the cylinder pin to ensure retainment.
 - a. Upper pin requires two belleville washers installed cupped towards each other as shown in figure 7.2. Shim any additional gap with standard washers that were removed when original cylinder was removed.

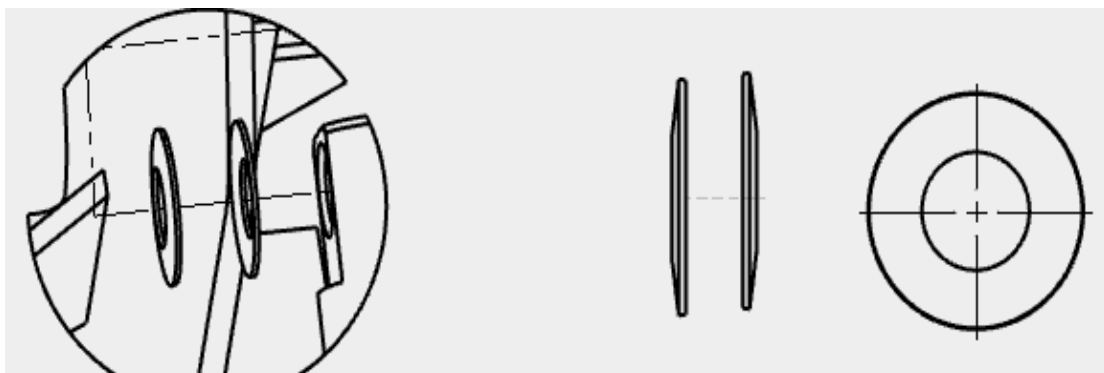

Figure 7.2

Service Bulletins are intended for use by Professional Technicians only. They are written to guide Professional Technicians in performing service to vehicles of specific nature in conjunction with industry standards. Professional Technicians should be appropriately trained on industry standards and have the tools and equipment to perform procedures safely and properly.



Recall Service Bulletin



Recall Service Bulletin
RSB24-230-001

- b. Install lower and upper cab tilt cylinder pins, washers, and cotter pins and split cotter pin ends to ensure retainment. The lower cylinder mount requires one Belleville washer and then regular washers as necessary to shim the gap and prevent cylinder clunking. See Figure 8.1

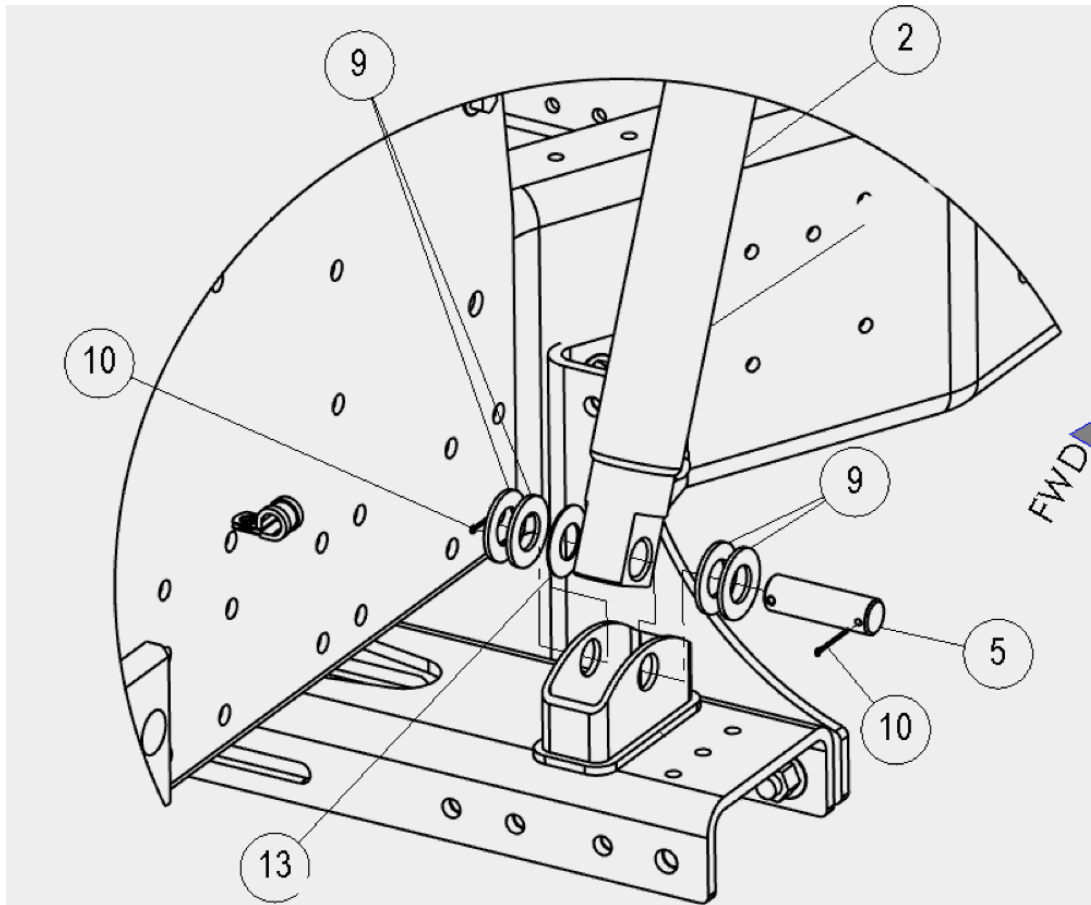

Figure 8.1

- 16) Reconnect hydraulic hoses.
17) Turn master switch on, ignition off.

Service Bulletins are intended for use by Professional Technicians only. They are written to guide Professional Technicians in performing service to vehicles of specific nature in conjunction with industry standards. Professional Technicians should be appropriately trained on industry standards and have the tools and equipment to perform procedures safely and properly.



Recall Service Bulletin



Recall Service Bulletin RSB24-230-001

- 18) Raise cab until safety lock bar is in place.
- 19) Add Dexron 3 ATF to the cab tilt pump reservoir as needed.
- 20) Reconnect radiator stay rod lower bolts and torque the bolt side to 93 ft. lbs. *See Figure 9.1*

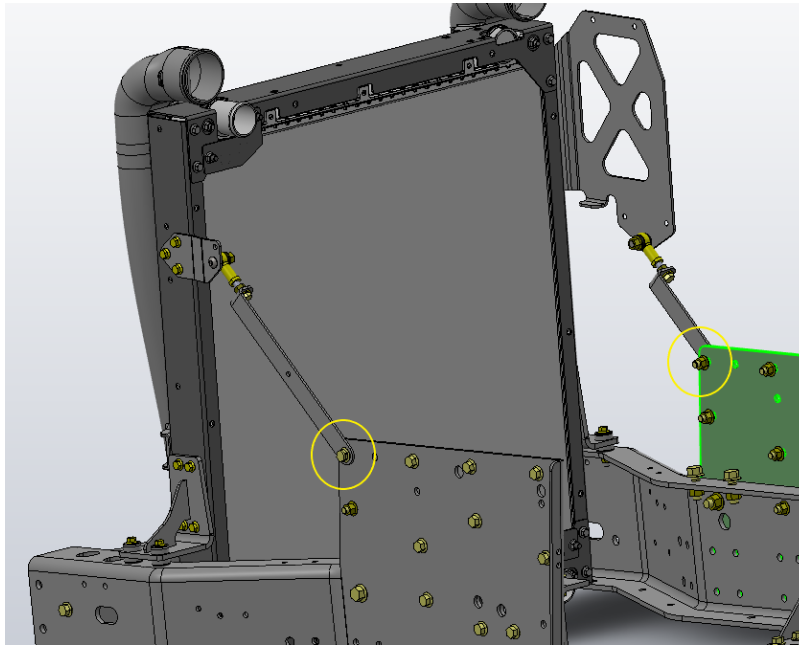

Figure 9.1

- 21) Release safety lock bar and lower the cab until the cab tilt pendent light extinguishes.
- 22) Replacement is complete.

23) **Important!!! Scrap Removed Cylinders**

Pull the rods out of the removed cylinders, then dispose of the cylinder barrels and rods. The rods will pull out without disassembling the cylinder as there is no mechanical stop in the rods being removed.

Service Bulletins are intended for use by Professional Technicians only. They are written to guide Professional Technicians in performing service to vehicles of specific nature in conjunction with industry standards. Professional Technicians should be appropriately trained on industry standards and have the tools and equipment to perform procedures safely and properly.



Recall Service Bulletin



Recall Service Bulletin
RSB24-230-001

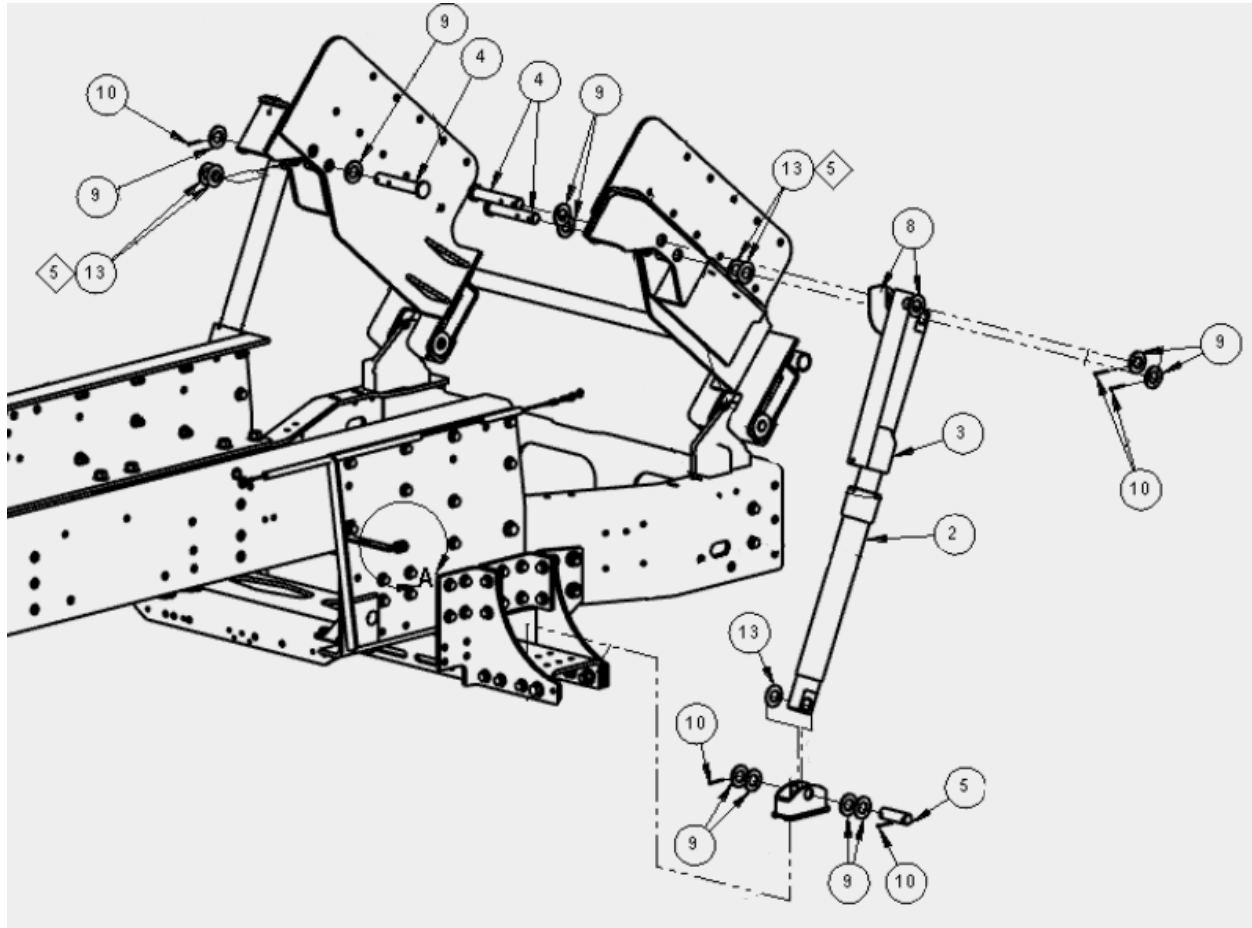

Service Bulletins are intended for use by Professional Technicians only. They are written to guide Professional Technicians in performing service to vehicles of specific nature in conjunction with industry standards. Professional Technicians should be appropriately trained on industry standards and have the tools and equipment to perform procedures safely and properly.