



Volvo Car Customer Service

QB Instruction VCC-530242-1

Title	Push rod brake booster	Page	1 (9)
Action	Adjustment	Operation number:	97568-2

Issue	Date	Reason
1	2024-10	First issue

Affected vehicles

Model year	Model
2020, 2021	S60 (19-)
2020, 2021	S90 (17-)
2020, 2021	S90L
2020, 2021	V60 (19-)
2020, 2021	V90 (17-)
2020, 2021	V90 Cross Country
2020, 2021	XC60 (18-)
2020, 2021	XC90 (16-)

Equipment

Designation	Part No.
Clip remover	
Brake pipe wrench	

Click on this link to view a short video on the "PushRod" repair method

<https://youtu.be/9gyhZyuI93c>

Color symbols

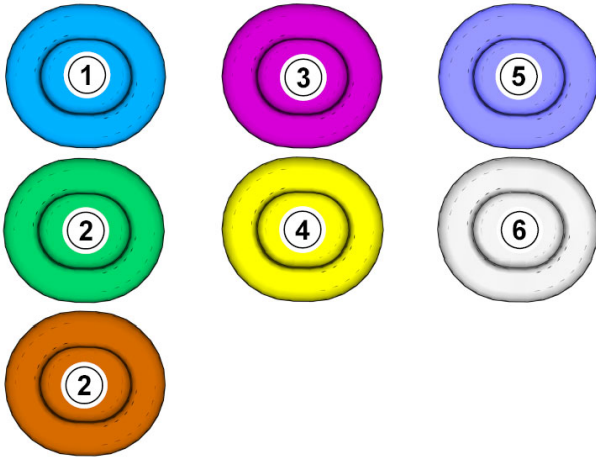

Note! This colour chart displays (in colour print and electronic version) the importance of the different colours used in the images of the method steps.

- 1 . Used for focused component, the component with which you will do something.
- 2 . Used as extra colors when you need to show or differentiate additional parts.
- 3 . Used for attachments that are to be removed/installed. May be screws, clips, connectors, etc.
- 4 . Used when the component is not fully removed from the vehicle but only hung to the side.
- 5 . Used for standard tools and special tools.
- 6 . Used as background color for vehicle components.

Removal

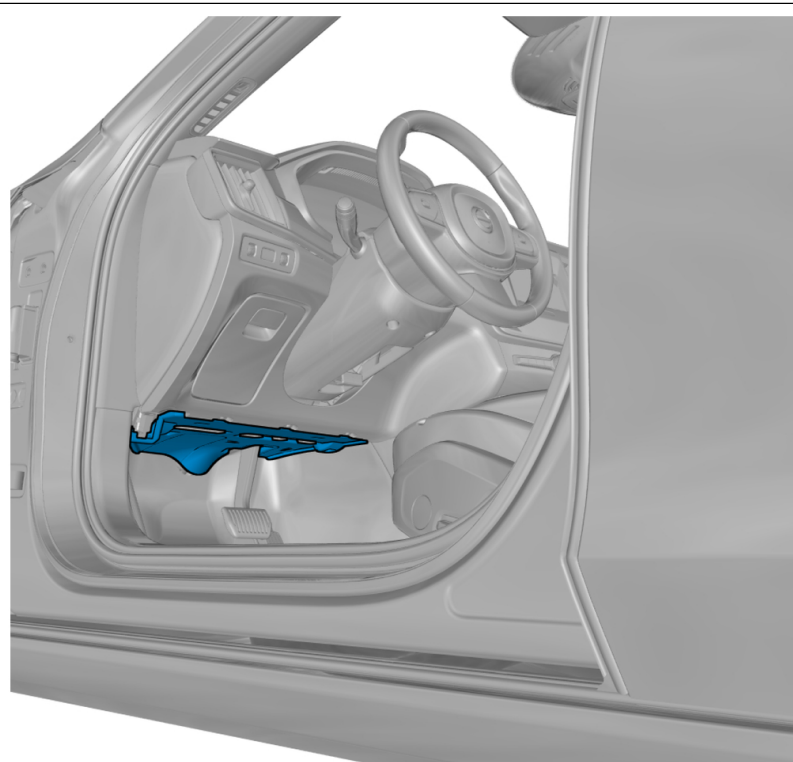

Note! Orientation view

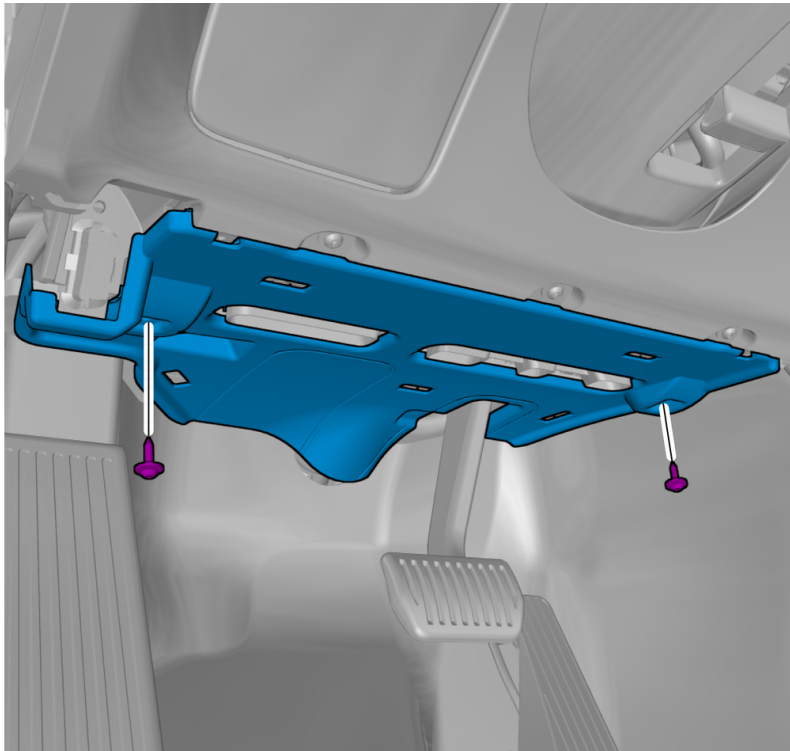

Remove the screws.

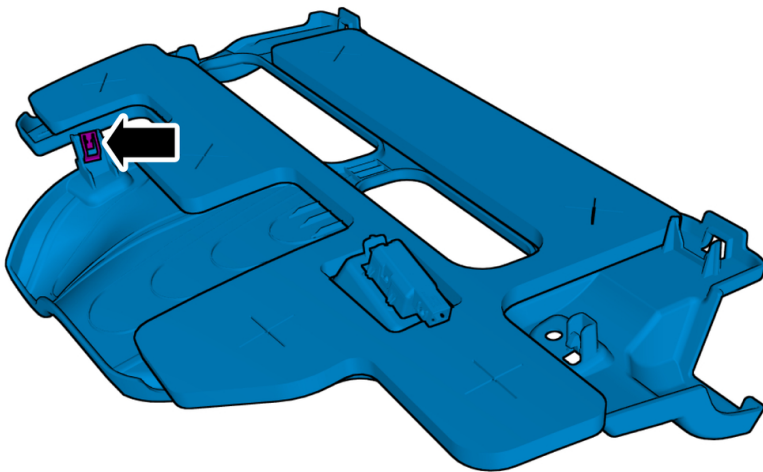

Note! The graphic shows the back of the component before removal.

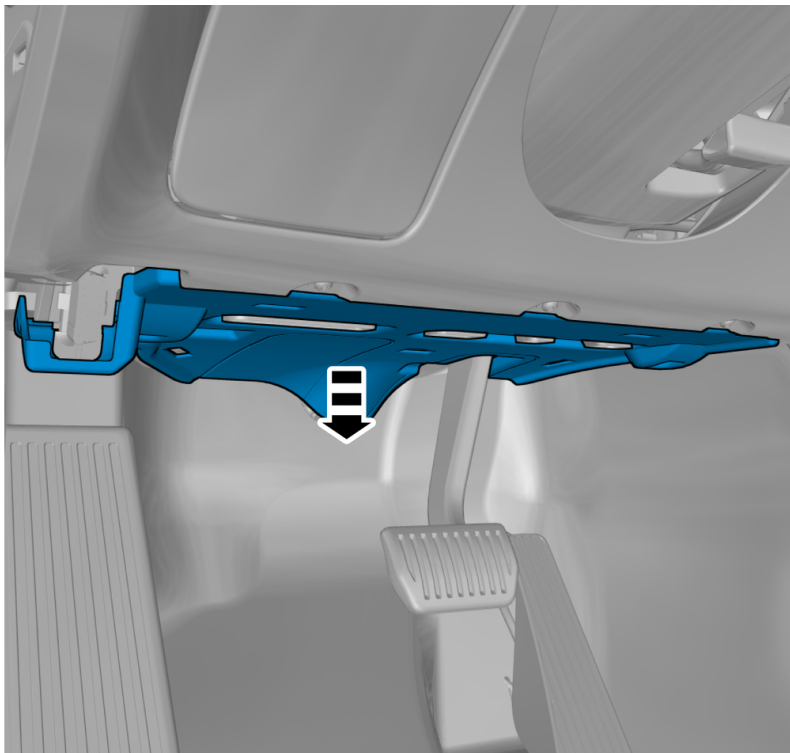

Remove the panel.

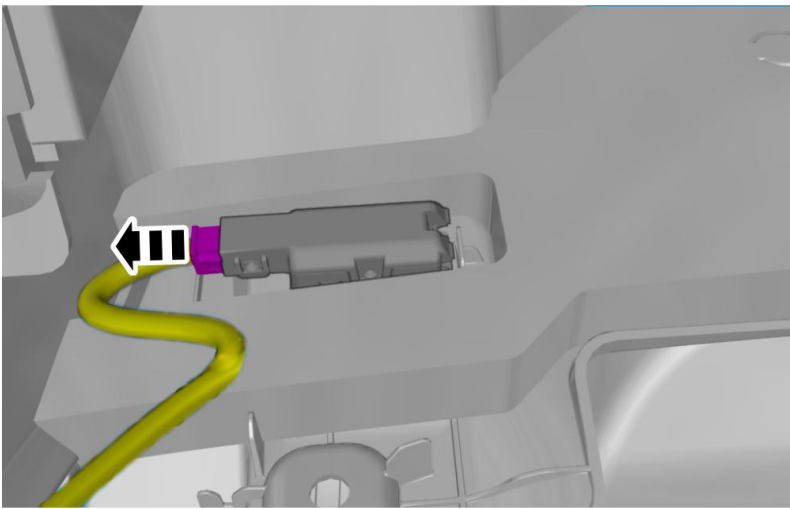

Disconnect the connector.

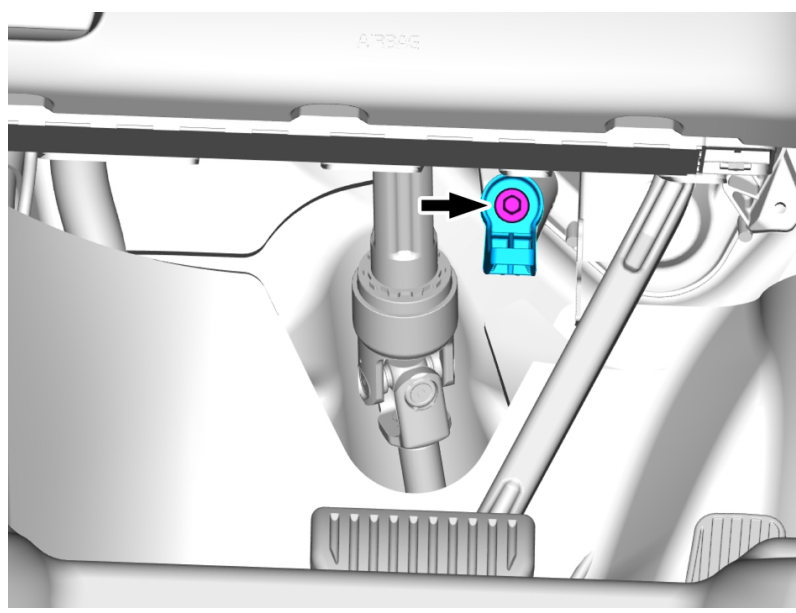

Remove the screw.
Remove the marked part.

Torque:

M5 , 5 Nm

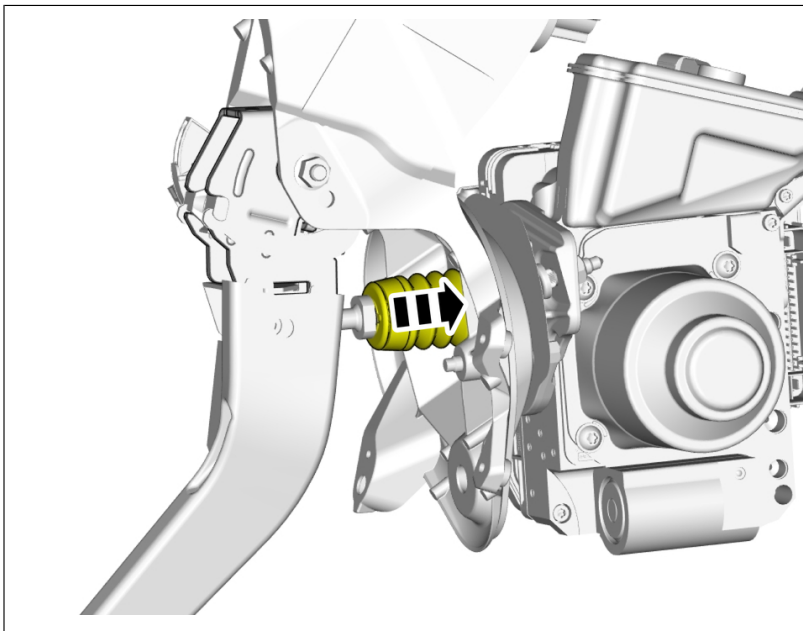

Pull the component in direction of the arrow.
Use your fingers.
Note position of components.

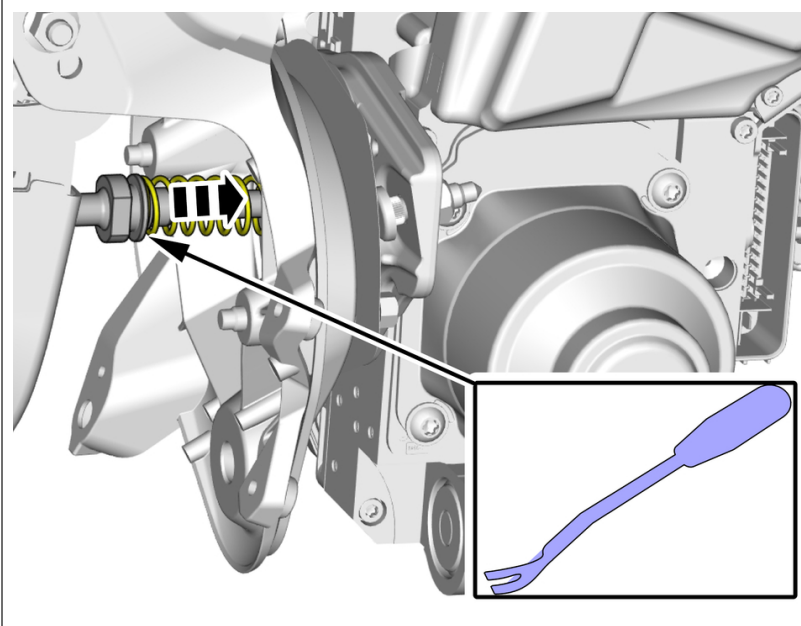

Use: Clip remover

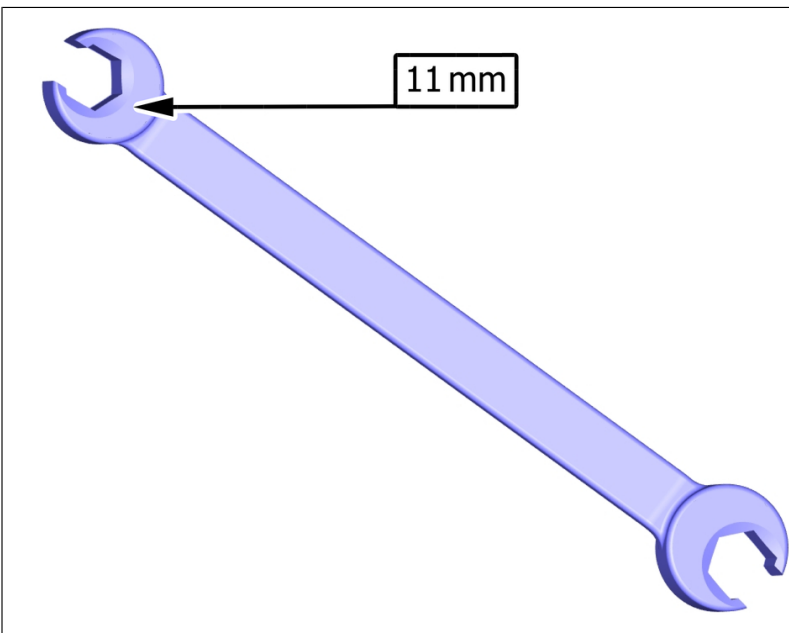

Note! Tool suggestion:

Use: Brake pipe wrench

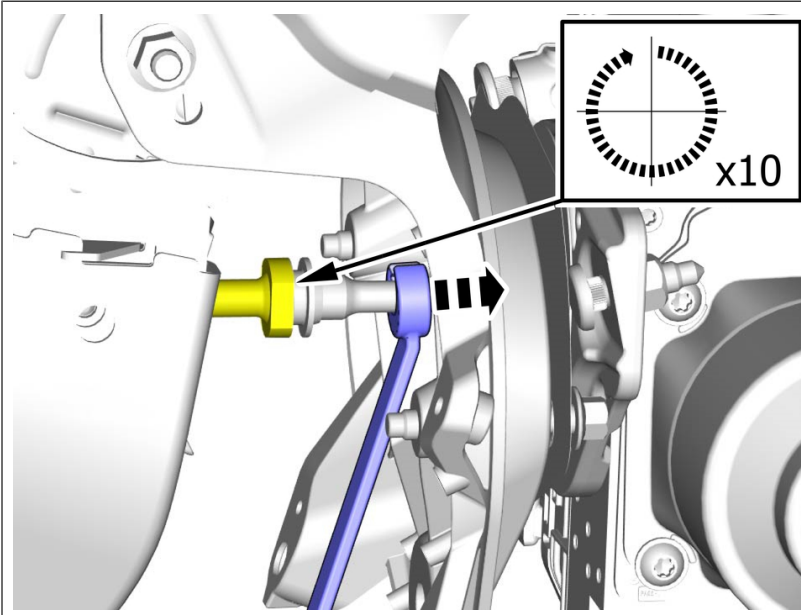

Use your fingers.

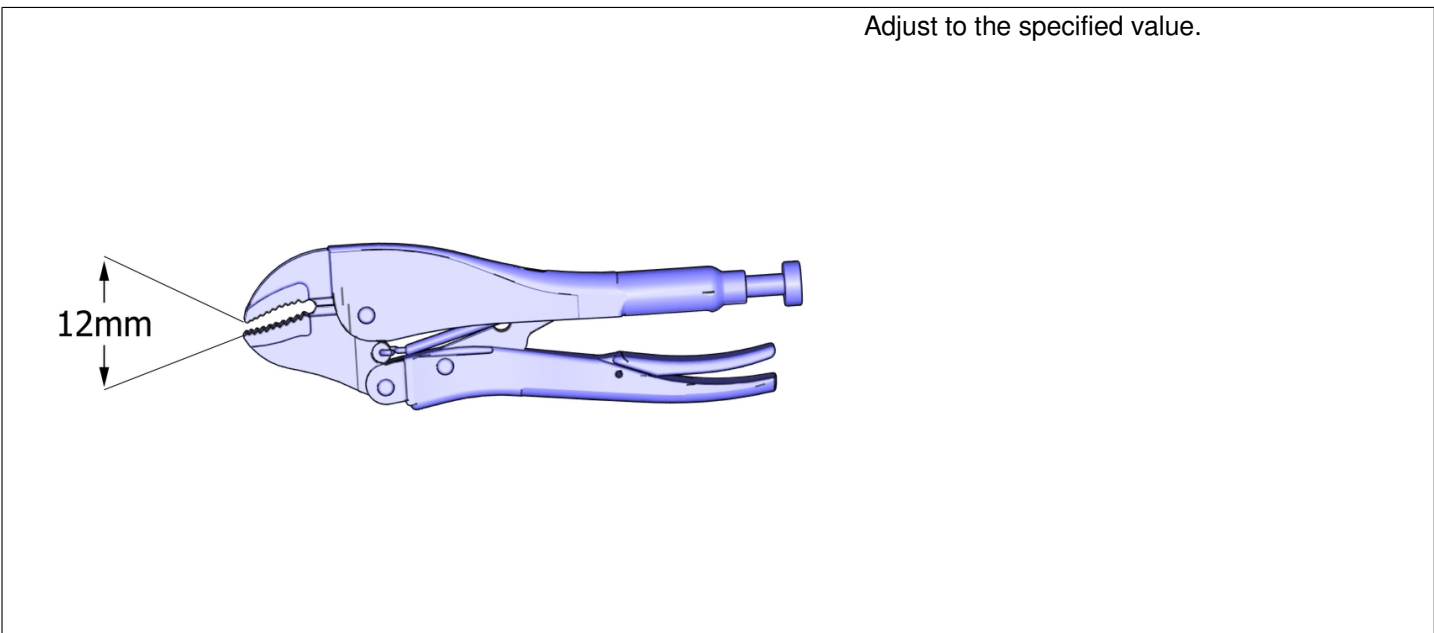

Adjust to the specified value.

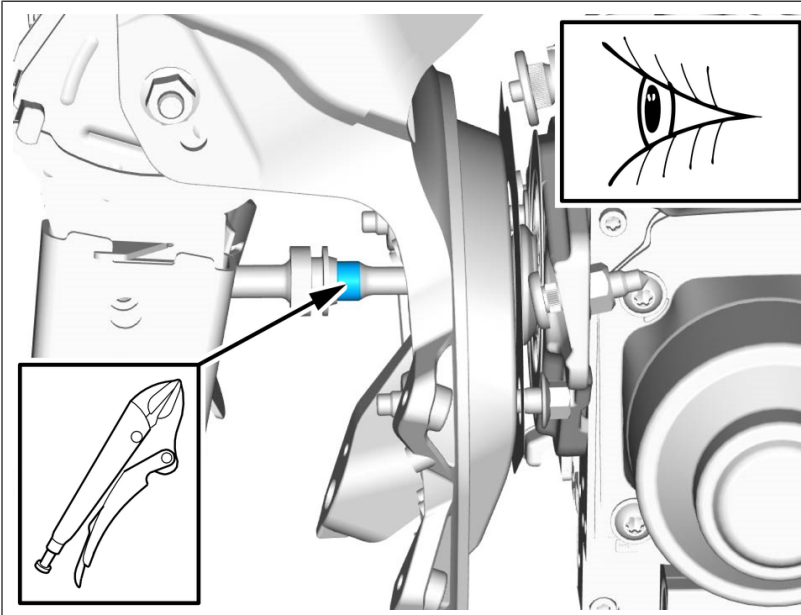

Caution! Note the placing of the tool.
Universal grip pliers

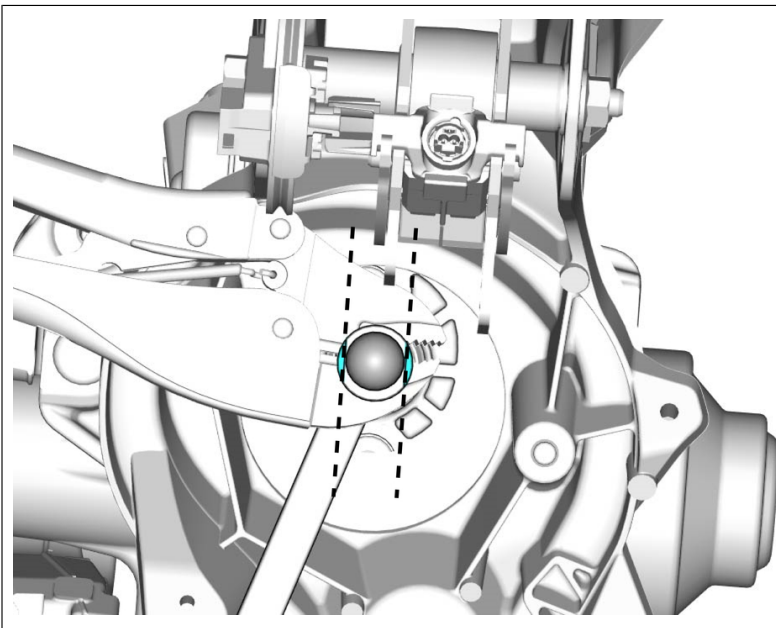

Note! Note the position.

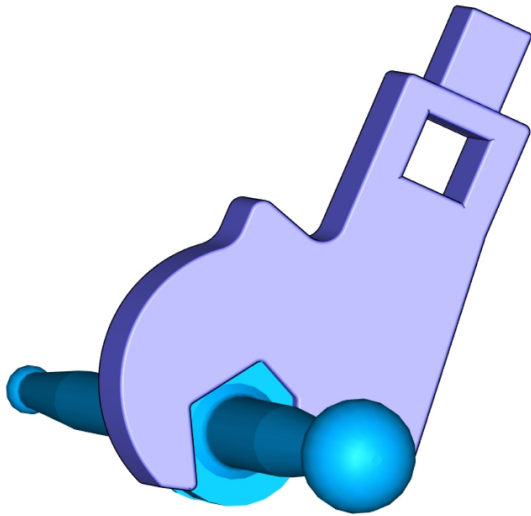

Universal grip pliers
Place tool according to image.

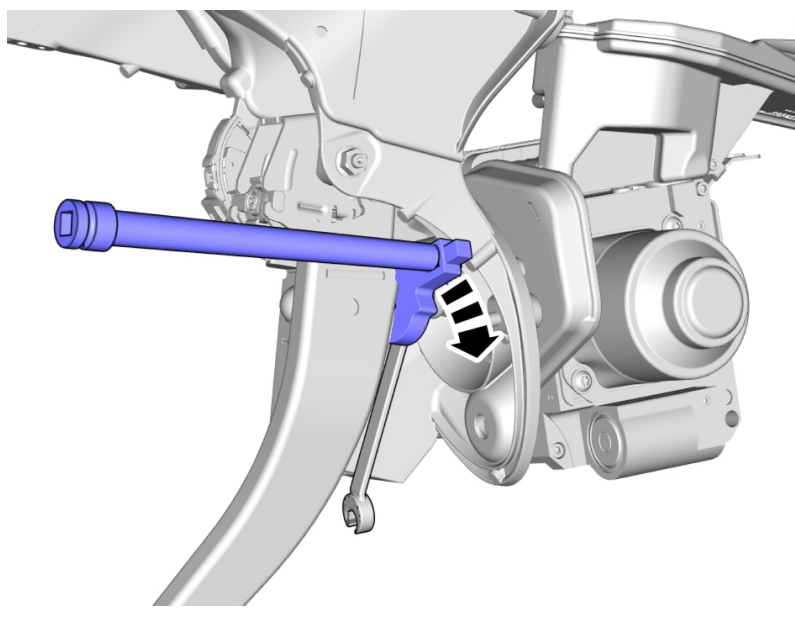

Tighten the screw.

Torque:

Push rod brake booster , 16 Nm

Installation

To install, reverse the removal procedure.