

SIDE VIEW

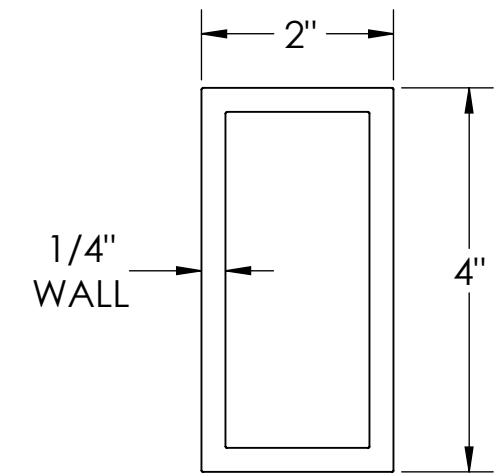

END VIEW

SCALE: 1:2

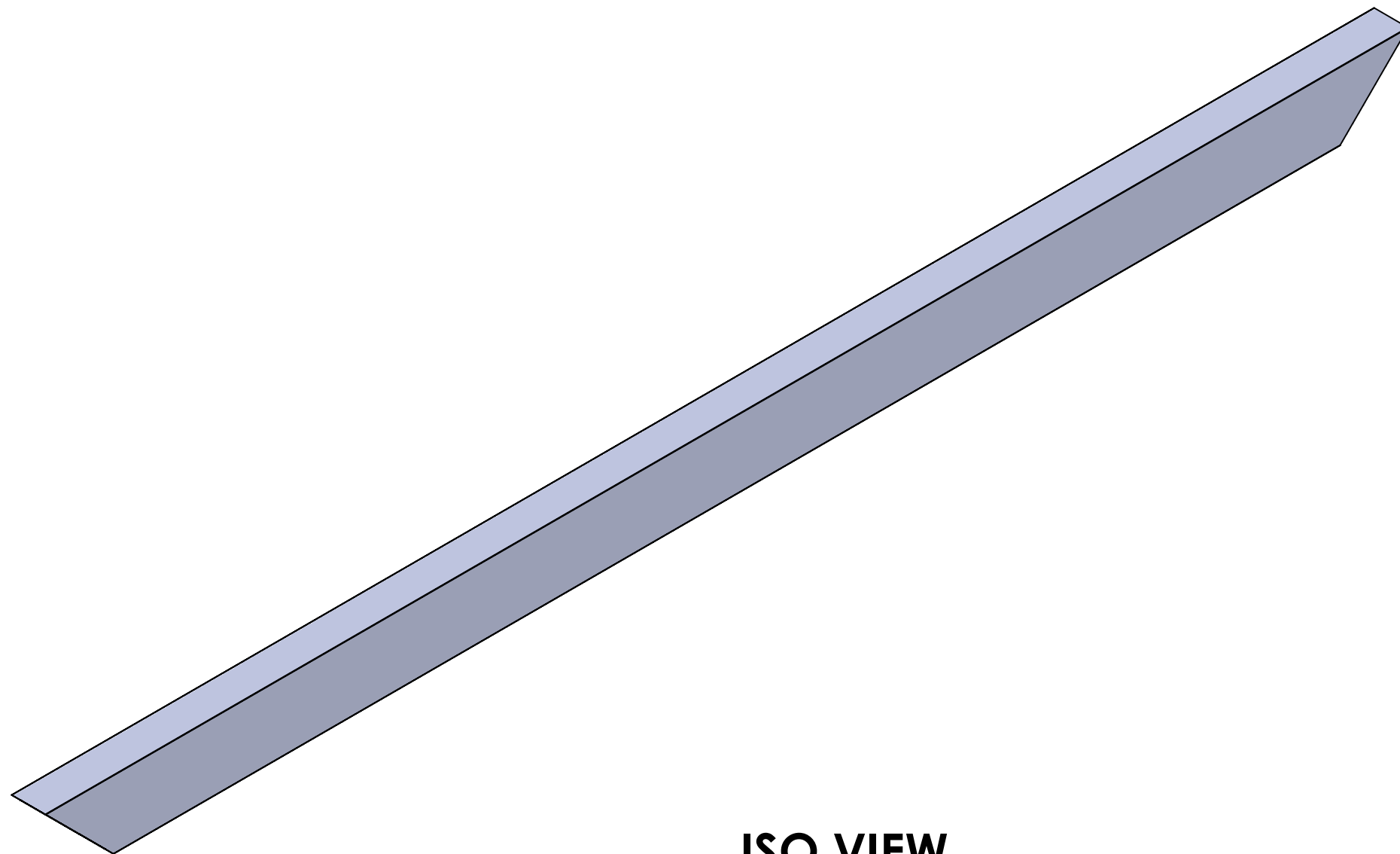

ISO VIEW

QUANTITY PER INSTALLATION: 2

FOR FRAME	DIMENSION TOLERANCES	ALL DIMENSIONS ARE NOMINAL UNLESS CRITICAL DIMENSIONS ARE SPECIFICALLY NOTED	TITLE: EXTRUSION, ALUMINUM, TUBE, 2.00" X 4.00" X 0.250", 80.00"L, 6005-T5 MATERIAL: (THICKNESS - TYPE - ALLOY - SIZE)	ACUMATICA PN:
EXTERIOR	STANDARD			DRAWN BY: REVISION:
INTERIOR	+ .1/16", 1.0°			SS
STRUCTURAL	CRITICAL + .1/32", 0.5°			DATE: 10/17/24
REVISION TABLE			WEIGHT: 20.39 LBS	SCALE: 1:6
REV.	DESCRIPTION	DATE	DONE BY	SHEET 1 OF 5



PROPRIETARY AND CONFIDENTIAL: THE INFORMATION CONTAINED IN THIS DRAWING IS THE SOLE PROPERTY OF ATC TRAILERS. ANY REPRODUCTION IN PART OR AS A WHOLE WITHOUT THE WRITTEN PERMISSION OF ATC TRAILERS IS PROHIBITED.

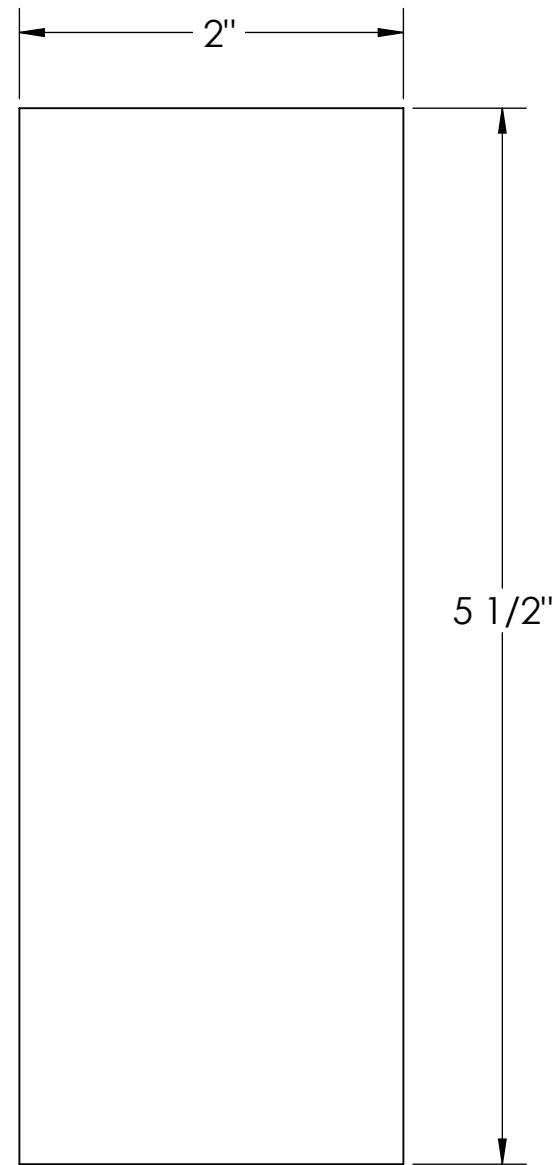

FRONT VIEW

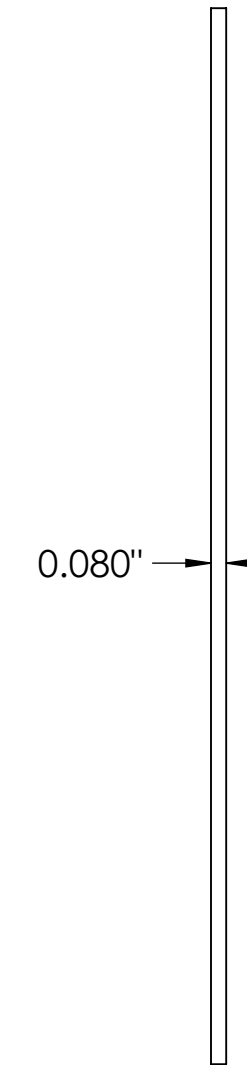

SIDE VIEW

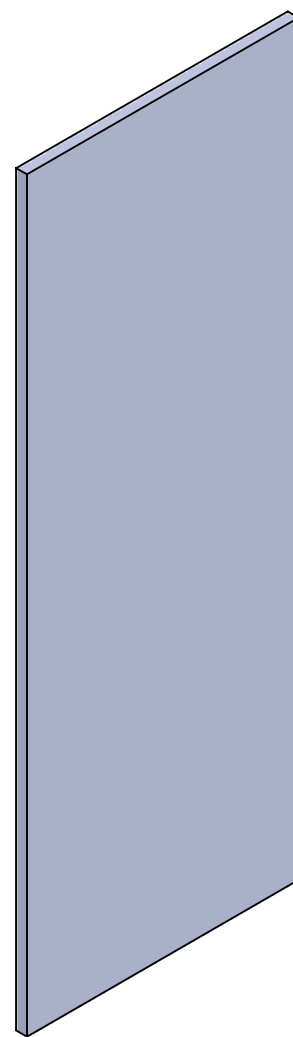

ISO VIEW

QUANTITY PER INSTALLATION: 4

FOR FRAME	DIMENSION TOLERANCES	ALL DIMENSIONS ARE NOMINAL UNLESS CRITICAL DIMENSIONS ARE SPECIFICALLY NOTED
EXTERIOR	STANDARD	
INTERIOR	+ .1/16", 1.0°	
STRUCTURAL	CRITICAL + .1/32", 0.5°	

TITLE: EXTRUSION, ALUMINUM, BAR, 2.00" X 5.50 X 0.080", 6063-T5 - END CAP
 MATERIAL: (THICKNESS - TYPE - ALLOY - SIZE)



PROPRIETARY AND CONFIDENTIAL: THE INFORMATION CONTAINED IN THIS DRAWING IS THE SOLE PROPERTY OF ATC TRAILERS. ANY REPRODUCTION IN PART OR AS A WHOLE WITHOUT THE WRITTEN PERMISSION OF ATC TRAILERS IS PROHIBITED.

ACUMATICA PN: **0014212**
 DRAWN BY: SS
 REVISION: SS
 DATE: 10/17/24
 SCALE: 1:1

WEIGHT: 0.09 LBS

FILE NAME: TONGUE REINFORCEMENT, STACKER TRAILER

REVISION TABLE

REV.	DESCRIPTION	DATE	DONE BY

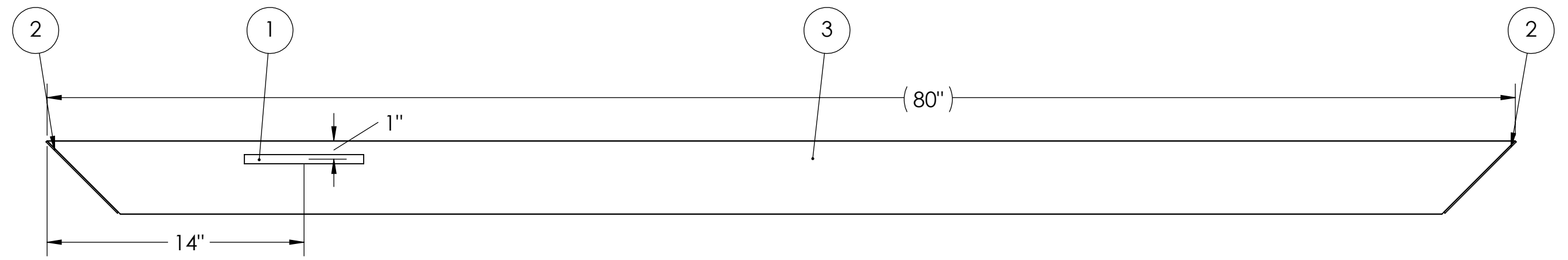

SIDE VIEW

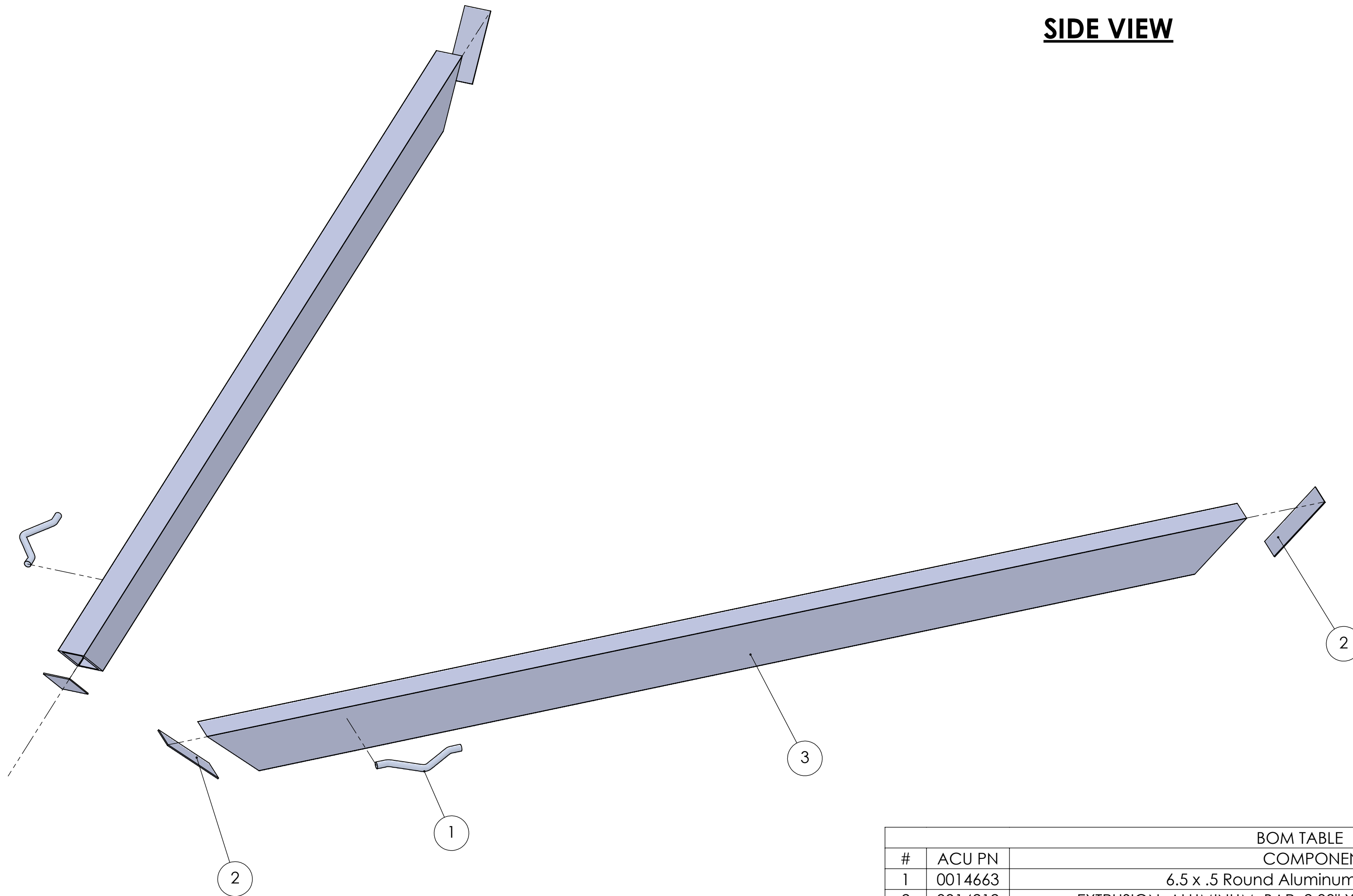

ISO EXPLODED VIEW

BOM TABLE			
#	ACU PN	COMPONENT NAME	QTY
1	0014663	6.5 x .5 Round Aluminum Formed Chain Hook	2
2	0014212	EXTRUSION, ALUMINUM, BAR, 2.00" X 5.50 X 0.080", 6063-T5 - END CAP	4
3		EXTRUSION, ALUMINUM, TUBE, 2.00" X 4.00" X 0.250", 80.00"L, 6005-T5	2

FOR FRAME	DIMENSION TOLERANCES ALL DIMENSIONS ARE NOMINAL UNLESS CRITICAL DIMENSIONS ARE SPECIFICALLY NOTED	
EXTERIOR		STANDARD $+1/16"$, 1.0°
INTERIOR		CRITICAL $+1/32"$, 0.5°
STRUCTURAL		

TITLE: **TONGUE REINFORCEMENT, STACKER TRAILER - PARTS REQUIRED**
 MATERIAL: (THICKNESS - TYPE - ALLOY - SIZE)
 ACUMATICA PN:
 DRAWN BY: SS
 REVISION: SS
 DATE: 10/17/24
 SCALE: 1:6
 PROPRIETARY AND CONFIDENTIAL: THE INFORMATION CONTAINED IN THIS DRAWING IS THE SOLE PROPERTY OF ATC TRAILERS. ANY REPRODUCTION IN PART OR AS A WHOLE WITHOUT THE WRITTEN PERMISSION OF ATC TRAILERS IS PROHIBITED.



WEIGHT: 41.40 LBS

REVISION TABLE			
REV.	DESCRIPTION	DATE	DONE BY

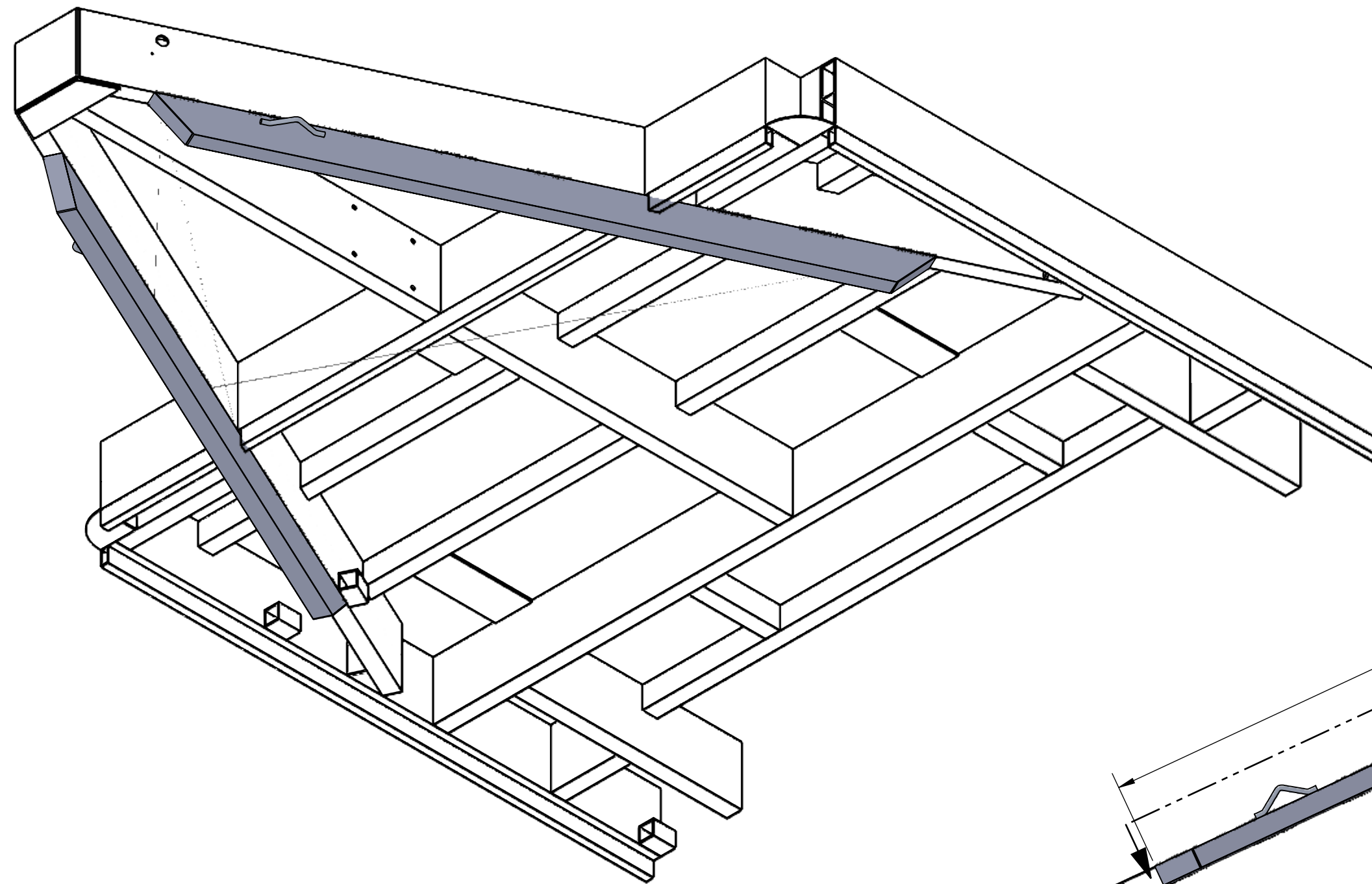

BOTTOM ISO VIEW

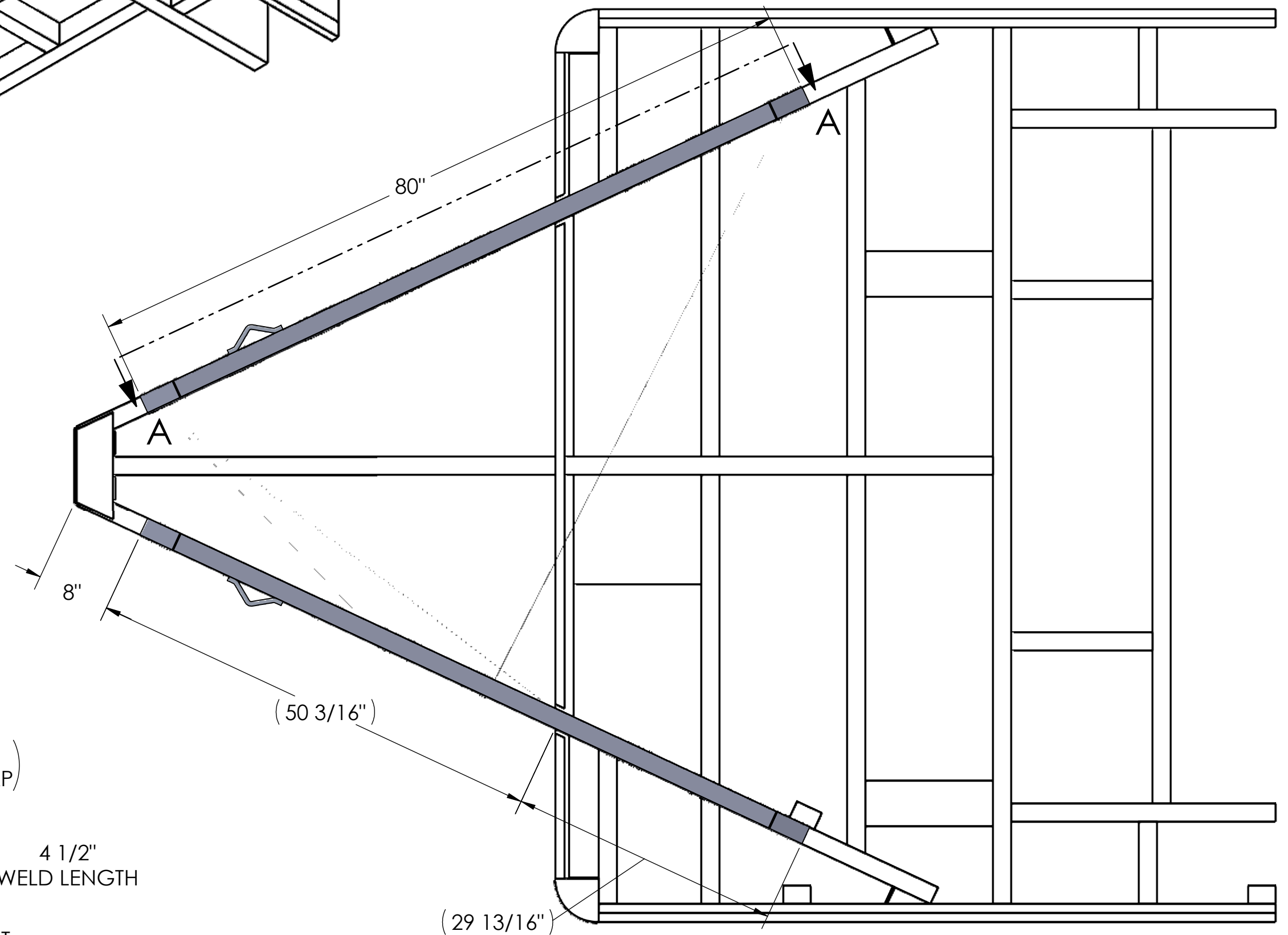

BOTTOM VIEW

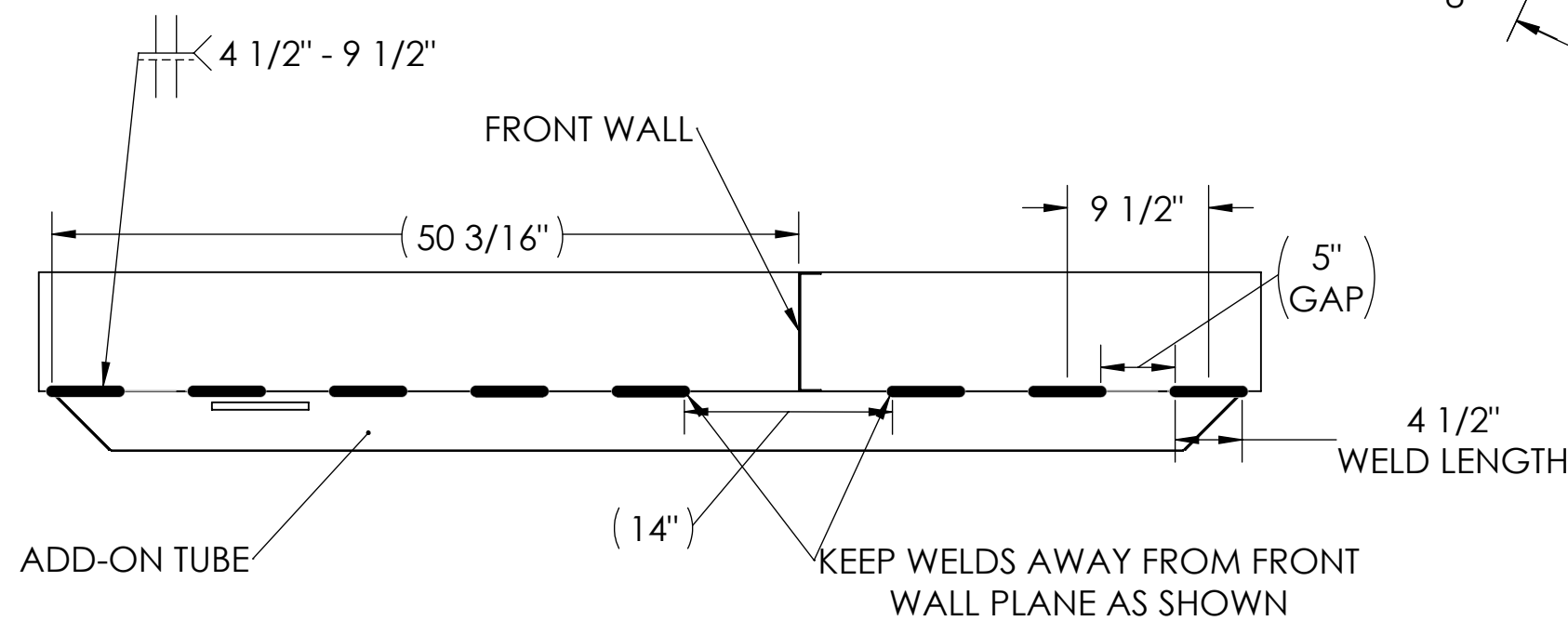

SIDE VIEW - WELD LENGTH AND GAP

(8) WELDS ON EACH SIDE OF TUBE
SECTION A-A

FOR FRAME	DIMENSION TOLERANCES	ALL DIMENSIONS ARE NOMINAL UNLESS CRITICAL DIMENSIONS ARE SPECIFICALLY NOTED
EXTERIOR	STANDARD	
INTERIOR	+1/16", 1.0"	
STRUCTURAL	+1/32", 0.5"	

TITLE: TONGUE REINFORCEMENT, STACKER TRAILER
MATERIAL: (THICKNESS - TYPE - ALLOY - SIZE)



PROPRIETARY AND CONFIDENTIAL: THE INFORMATION CONTAINED IN THIS DRAWING IS THE SOLE PROPERTY OF ATC TRAILERS. ANY REPRODUCTION IN PART OR AS A WHOLE WITHOUT THE WRITTEN PERMISSION OF ATC TRAILERS IS PROHIBITED.

ACUMATICA PN:
DRAWN BY: SS
REVISION:
DATE: 10/17/24
SCALE: 1:12
SHEET 4 OF 5

REVISION TABLE			
REV.	DESCRIPTION	DATE	DONE BY

DWG PATH: C:\Eng_Vault\R&D\R&D Projects\PROJECTS\~Tongue Project\Stacker\Repair Procedure\

WEIGHT: LBS
FILE NAME: TONGUE REINFORCEMENT, STACKER TRAILER - INSTALLATION

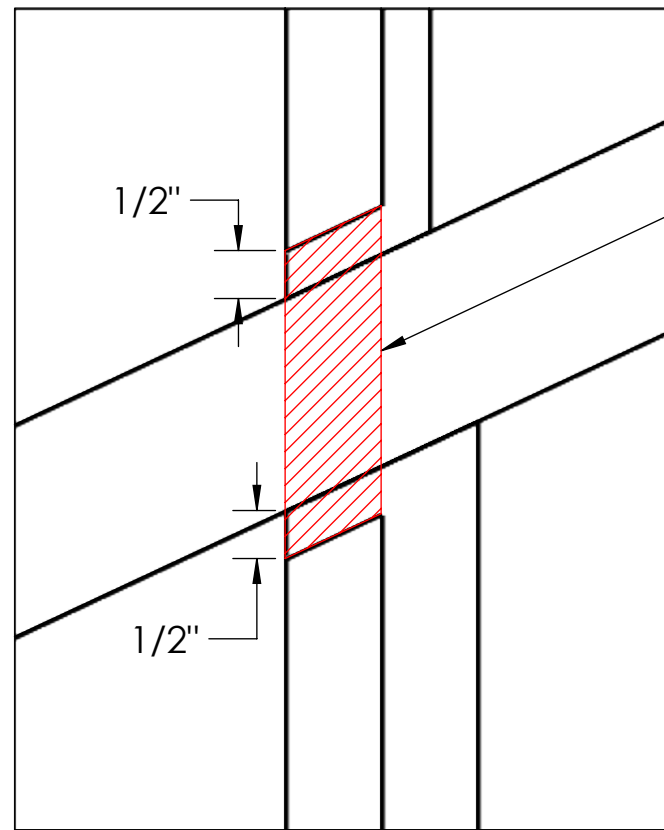

IF TRAILER HAS 2" DROP SKIRTING, THE GRAVEL GUARD BACKER TUBE MUST BE CUT OUT BELOW THE (2) OUTER TONGUE MEMBERS AS SHOWN. DO NOT WELD THE ADD-ON TUBES TO THIS BACKER.

2" DROP SKIRTING MODIFICATION
(IF OPTIONED)

DETAIL B
SCALE 1 : 2

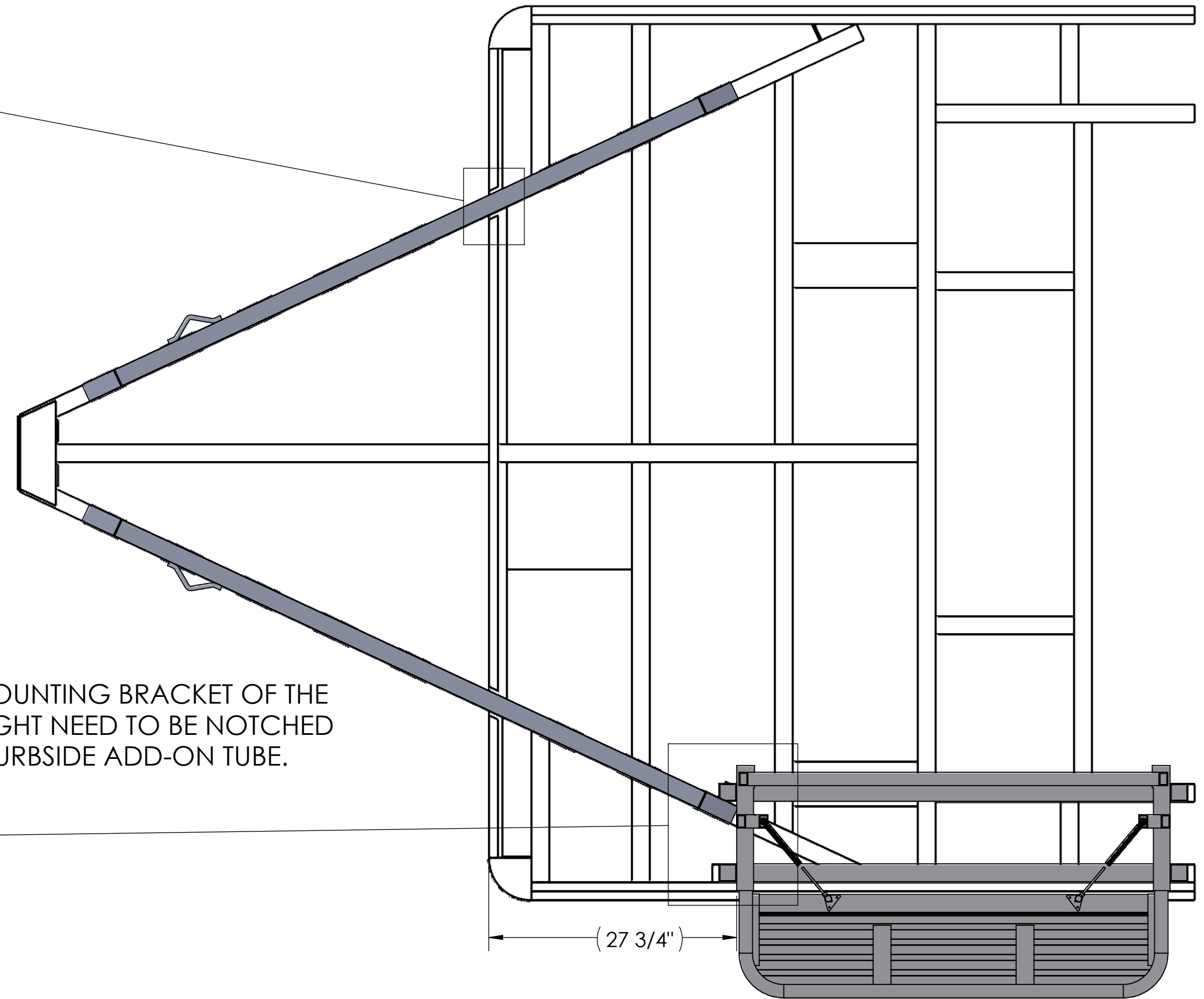

BOTTOM VIEW

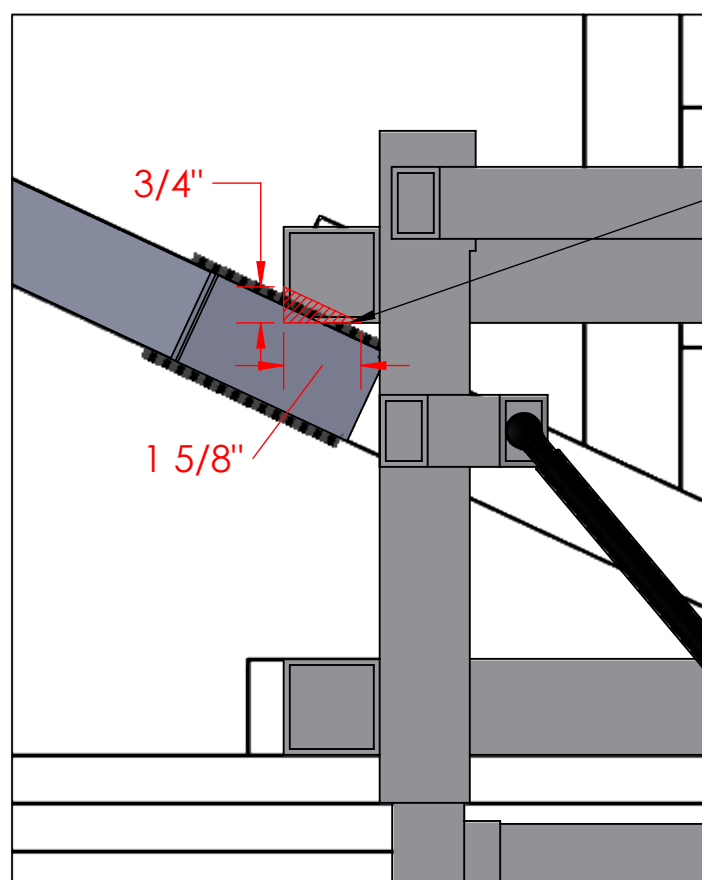

THE FRONT, INNER MOUNTING BRACKET OF THE SLIDE IN/OUT STEP MIGHT NEED TO BE NOTCHED TO FIT WITH THE CURBSIDE ADD-ON TUBE.

SLIDE IN/OUT STEP MODIFICATION
(IF REQUIRED)

DETAIL C
SCALE 1 : 4

REVISION TABLE			
REV.	DESCRIPTION	DATE	DONE BY

FOR FRAME	DIMENSION TOLERANCES	ALL DIMENSIONS ARE NOMINAL UNLESS CRITICAL DIMENSIONS ARE SPECIFICALLY NOTED
EXTERIOR	STANDARD + .1/16", 1.0°	
INTERIOR	CRITICAL + .1/32", 0.5°	
STRUCTURAL		

TITLE: TONGUE REINFORCEMENT, STACKER TRAILER
 MATERIAL: (THICKNESS - TYPE - ALLOY - SIZE)
 WEIGHT: _____ LBS
 PROPRIETARY AND CONFIDENTIAL: THE INFORMATION CONTAINED IN THIS DRAWING IS THE SOLE PROPERTY OF ATC TRAILERS. ANY REPRODUCTION IN PART OR AS A WHOLE WITHOUT THE WRITTEN PERMISSION OF ATC TRAILERS IS PROHIBITED.



ACUMATICA PN:
 DRAWN BY: SS
 REVISION: SS
 DATE: 10/17/24
 SCALE: 1:12