

## **SAFETY RECALL CAMPAIGN 3A04**

### **2022 - 2024 Hayabusa Front Brake Master Cylinder Parts Replacement**

- Affected Models:** 2022 ~ 2024 Hayabusa (GSX1300R\_M2~M4) motorcycles
- Affected Departments:** Management, Service, Warranty, Sales, Parts, Accessories
- Attachments:** [Sales Bulletin 24-097](#) (Hayabusa Stop Sales) & Customer Notification Letter
- Reference:** [Hayabusa GSX1300R Service Manual](#) (99500-10L00-03E),  
& [Service Bulletin GS/GSX/GSX-R No. 259](#) (2022 Hayabusa Front Brake Master Cylinder Body Replacement Recall 2A99)

This notice is sent to you in accordance with the requirements of the National Traffic and Motor Vehicle Safety Act. Suzuki Motor Corporation (SMC) has determined that a safety defect exists in 2022 – 2024 Hayabusa (GSX1300RM2 – M4) model motorcycles.

#### **STOP DELIVERY OF AFFECTED VEHICLES IMMEDIATELY**

**DO NOT SELL OR DELIVER** an affected motorcycle to a customer until you have completed or verified completion of the repair procedures outlined in this bulletin.

It is a violation of Federal law to sell or deliver any new motorcycle, scooter, ATV, or item of motor vehicle equipment subject to a safety recall campaign under a sale or lease until the defect or non-compliance has been corrected.

In addition, selling an unrepaired affected motorcycle, scooter, or ATV is a direct violation of your Suzuki dealer agreement and may lead to additional sanctions.

#### **What is the defect?**

Suzuki Motor Corporation is initiating a safety recall campaign to replace parts in the front brake master cylinder.

Migration of certain elements present in the brake fluid cap diaphragm into the brake fluid could cause the brake fluid to react to rubber seal components within the front brake master cylinder and cause them to swell. Swelling of the primary seal cup seal could cause blockage of the master cylinder primary port and could cause excessive front brake lever travel during an initial application of the front brake. Under the worst-case condition, the vehicle may experience increased braking distance, increasing the risk of a crash.

#### **Contents of this bulletin:**

<a href="#">What Suzuki Will Do</a>	2
<a href="#">What Your Dealership Will Do &amp; Customer Incentive Service</a>	2 & 3
<a href="#">Affected VIN Range &amp; Checking Repair Status on Suzuki CONNECT</a>	3
<a href="#">Auto-shipped Parts &amp; Ordering Recall Service Parts</a>	4
<a href="#">Recall Service Parts Identification</a>	5
<a href="#">Recall Warranty Claim Processing Information</a>	6
<a href="#">Customer Incentive Service Claim Processing Information &amp; 2A99 Parts Returns</a>	7
<a href="#">Recall Service Repair Instructions</a>	8 - 20
<a href="#">Suzuki Dealer STOP SALES bulletin</a>	21 - 22
<a href="#">Customer Notification Letter</a>	23 - 24
<a href="#">Customer Incentive Service Checklist</a>	25

### **What is Suzuki Motor Corporation (SMC) doing to solve the problem?**

Under recall campaign 3A04, SMC is directing Suzuki dealers to replace the affected front brake master cylinder parts with new parts. The new parts include a master cylinder body, and a reservoir cap diaphragm manufactured with an updated material that will not cause swelling of the master cylinder rubber parts. The repair will take approximately one hour to perform, and there will be no charge to Hayabusa owners for any recall-related parts or labor.

### **Important:**

Campaign 3A04 supersedes the previous 2A99 campaign for the Front Brake Master Cylinder recall on the 2022 Hayabusa (GSX1300RM2) models. Even if a Hayabusa had recall 2A99 performed in the past, your dealership must still perform the 3A04 campaign on the motorcycle. If a Hayabusa never had the 2A99 recall performed, it will only require completion of the new 3A04 recall service. [See page 7 on how to return unused 2A99 recall campaign parts sets.](#)

### **What Suzuki Motor USA, LLC. (SMO) will do:**

Starting the week of October 25, 2024, SMO will mail notifications to owners of affected Hayabusa motorcycles for whom we have information. The notice instructs the customer to contact a Suzuki dealer to schedule an appointment to have the 3A04 Front Master Cylinder Parts Set recall service performed on their motorcycle.

[Page 4 of this bulletin lists the part number for the Front Master Cylinder Parts Set you will need to order from the SMO Parts Department to complete the recall service on a customer's affected Hayabusa motorcycle.](#)

### **What your dealership will do:**

1. [Please prioritize completion of the recall service for your affected Hayabusa customers.](#) For their safety and satisfaction, we strongly suggest you do not wait for them to contact you, but you should take the initiative to contact them to set an appointment to perform the recall service as soon as possible. Provide them the premium service that ownership of Suzuki's flagship sportbike conveys. If you need support to address a customer's needs or concerns, please call TECH LINE at (714) 996-7480 or contact your Technical Service and Parts Manager (TSPM).

### **What your dealership will do:**

1. Please prioritize completion of the recall service for your affected 2022 - 2024 Hayabusa customers. For their safety and satisfaction, we strongly suggest you do not wait for them to contact you, but you should take the initiative to contact them to set an appointment to perform the recall service as soon as possible. Provide them the premium service that ownership of Suzuki's flagship sportbike conveys. If you need support to address a customer's needs or concerns, please call TECH LINE or contact your TSPM.
2. Customers who bring their Hayabusa motorcycles into your dealership no later than **September 30, 2025** for the recall campaign 3A04 repair are eligible to have a **ECSTAR Oil Change & Maintenance Service Check** performed at the same time. [This free service check can only be performed when the motorcycle is in your dealership for the recall service.](#) Suzuki is sensitive to the inconvenience this recall campaign is to the Hayabusa owner and your dealership. This additional free service is an incentive and reward so your Hayabusa customers will respond promptly to this recall campaign. This additional service takes about 90 minutes to complete and provides you the opportunity to positively interact with your customer. **A towing option is also being offered to customers of affected units – please contact Tech-Line for review and instructions.**

REVISED

### **Service Check Parts & Labor Information:**

This customer incentive service includes an oil and oil filter service, plus a 30-point maintenance service check list that will help you identify immediate or future service needs on your customer's Hayabusa.

[See page 25 of this bulletin for the Service Check List form.](#)

<b>Required part:</b>	ECSTAR R9000 Full Synthetic Oil Change Kit (990A0-01E40-4KT, 4 quart) <i>Includes: (1) Oil filter, (1) Drain plug gasket, and (4 qt.) ECSTAR R9000 Engine Oil</i>
<b>Labor time:</b>	1.5 hours

[See page 7 for Service Check warranty claim information.](#)

**Note:** Provide a copy of the completed check list to the Hayabusa owner and keep a copy in your service department records. If you find a defect during the inspection and the motorcycle is within its warranty, please inform the customer and arrange to repair the defect, and then submit a warranty claim for the repair. If the issue is not a defect or the motorcycle is out of warranty, or SEP, inform the customer of the issue and provide an estimate for the retail repair.

**What your dealership will do (continued):**

3. Because **Front Master Cylinder Parts Sets for your unsold, affected Hayabusa motorcycles in your dealerships inventory are being automatically shipped to your dealership** check your unsold inventory for these affected 2022 - 2024 Hayabusa models so you can perform the recall service on them as soon as possible. **Remember: Do not order additional parts sets for your unsold Hayabusa inventory.** Once you have the recall service completed, submit a warranty request to SMO. **Remember: You must do this before selling or transferring the motorcycle.**
4. Refer to [Service Bulletin, General No. 144](#) on how to use Suzuki CONNECT and your dealership's records to determine which customers you have sold an affected 2022 - 2024 Hayabusa motorcycle. Contact the owner of the affected motorcycle to alert him/her that you are ordering the necessary recall service parts. Let the customer know there will be no charge for parts or labor. Offer to perform the **ECSTAR Oil Change & Maintenance Service Check** at the same time as the recall service repair. Set an appointment to perform the recall service and then submit a warranty request to SMO.
5. If your dealership is contacted by someone who has an affected 2022 - 2024 Hayabusa, but you did not sell the motorcycle use Suzuki CONNECT to verify recall status (see below). Let the owner know you can assist with the Front Brake Master Cylinder Parts Set recall service and the **ECSTAR Oil Change & Maintenance Service Check**. Let the customer know there will be no charge for parts or labor. You can then order the necessary recall service parts. Set an appointment to perform the recall service, complete the Service Check, and then submit the necessary warranty requests to SMO.

**Affected model VIN range:**

- All the motorcycles in the V.I.N. Range table below are affected.
- Some of the affected motorcycles for this 3A04 recall campaign were also covered under the previous "GSX1300RM2 (Hayabusa) Front Brake Master Cylinder Body Replacement Recall Campaign 2A99" that was announced in 2023.
- Therefore, you are required to perform recall 3A04 for the units which you have already completed the PREVIOUS 2A99 recall campaign. However, you should not perform the PREVIOUS 2A99 recall campaign if it has not yet been completed.
- [See page 7 on how to return unused 2A99 recall parts kits.](#)

Model	Spec	V.I.N. Range
GSX1300RRM2/M3/M4	E03	JS1EJ11B#N7100001 - JS1EJ11B#R7101566
	E33	JS1EJ11D#N7100001 - JS1EJ11D#R7100320

- All motorcycles in the VIN range above are affected, verify recall status with Suzuki CONNECT.
- “#” indicates any check digit from 0 to 9 and X.

**Use Suzuki CONNECT to verify recall status:**

Before performing the recall repair on a Hayabusa, first verify the repair needs to be performed by checking the motorcycle's VIN and accessing the Vehicle Master Inquiry on Suzuki CONNECT and checking the 3A04 campaign repair status.

If the recall repair needs to be performed, you will see the message “CAMPAIGN NOT YET PERFORMED.”

If you have a question regarding motorcycle eligibility, call TECH LINE at (714) 996-7480 or contact your Suzuki Technical Service & Parts Manager (TSPM).

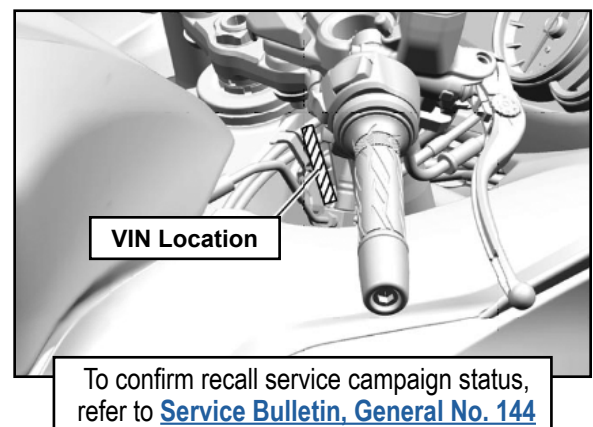

**Parts for unsold Hayabusa motorcycles automatically being shipped to your dealership:**

**Front Master Cylinder Parts Sets for your unsold, affected Hayabusa motorcycles are being automatically shipped to your dealership (beginning the week of 10/28/2024).** The V.I.N. of the motorcycle that the shipped parts are for listed on the shipping label. Do not order extra parts sets for unsold motorcycles in your inventory.

**Ordering parts for the Safety Recall Campaign:**

**Your dealership is responsible for ordering recall parts sets for previously sold, affected 2022 - 2024 Hayabusa motorcycles.** This includes customer-owned and trade-in motorcycles. Recall service parts will be available to order the week of 10/28/2024. Order the *Master Cylinder Parts Set* using the part number listed below using normal ordering procedures. You must also use the proper Suzuki ECSTAR DOT 4 brake fluid (see below). If you perform the customer incentive service *ECSTAR Oil Change & Maintenance Service Check*, you must use a Suzuki Genuine Parts / ECSTAR Oil Change Kit ([see page 2 for more information](#)).

**You must enter the last nine digits of the V.I.N. from your customer's affected Hayabusa into the memo field on Suzuki CONNECT order page or the order cannot be processed.**

You may see the PARTS SET, FR MASTER CYLINDER (59600-10870-RX0) listed as BO (Back Order) when checking parts availability or when placing an order for the parts set in Suzuki CONNECT. This is because SMO is manually fulfilling parts set orders to expedite shipments. **Because this is a unique situation, ignore the BO and order the master cylinder parts set as needed.**

If you have any questions regarding parts orders, please contact SMO Parts Coordination at (714) 854-2165.

**Recall service parts:**

Part Name	Part Number	Quantity	Includes
<b>PARTS SET, FR MASTER CYLINDER</b>	<b>59600-10870-RX0</b>	<b>1</b>	DIAPHRAGM, R (59667-23H10-RX0) x 1 ①
			CYLINDER SET, FRONT MASTER (59601-10LA0-RX0) x 1 ②
			NUT (08319-2106A) x 1 ③
			WASHER (09161-10009) x 2 ④

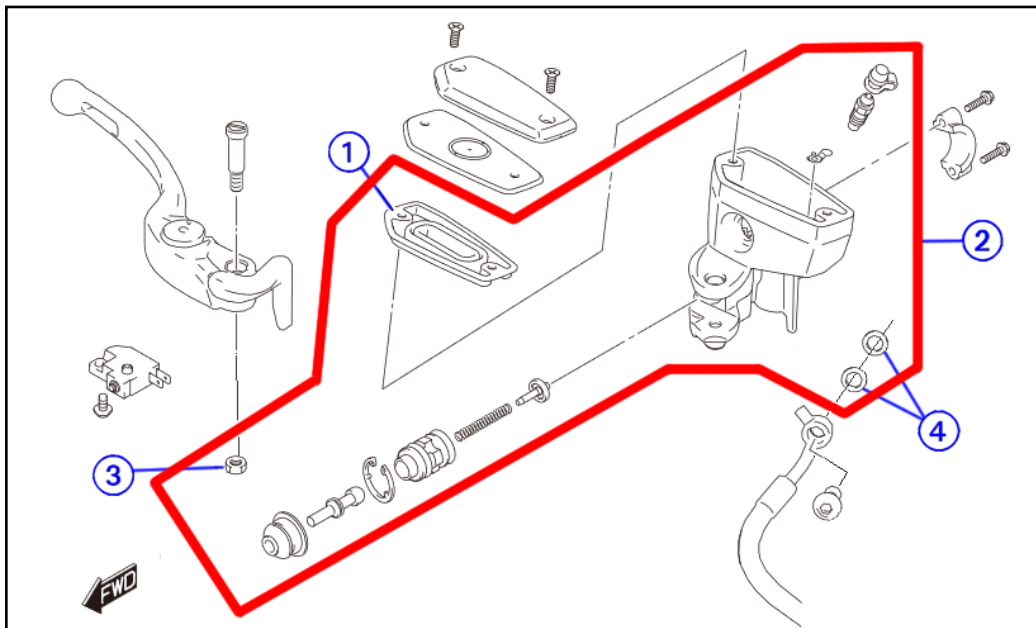

**Brake fluid:**

You will be reimbursed for brake fluid used in the recall service.



The required brake fluid is Suzuki **ECSTAR DOT 4 (990A0-01E91-12Z)**.

**Recall service parts identification:**

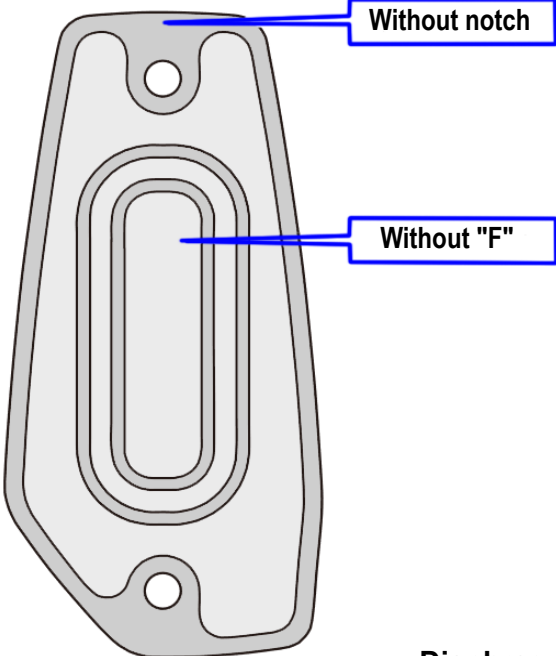
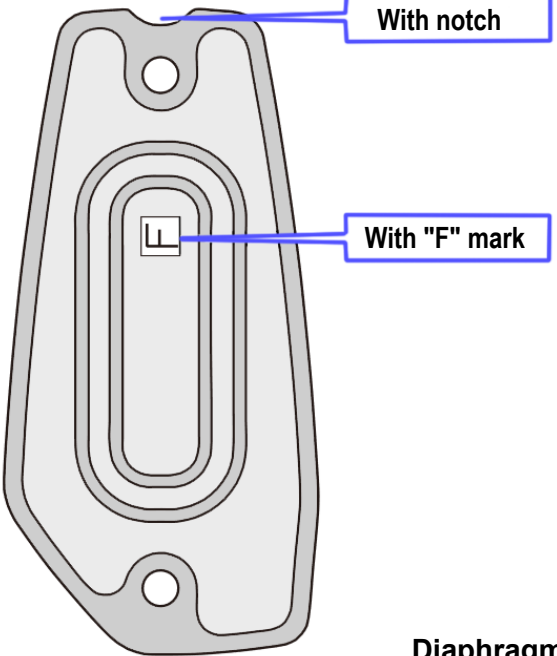
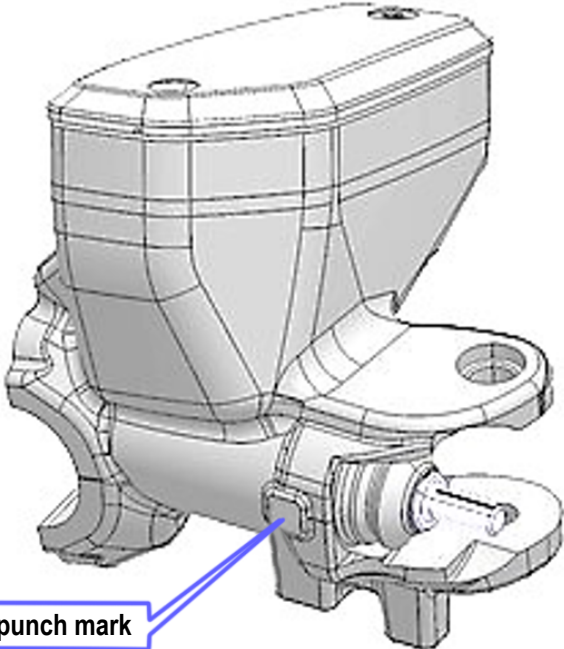
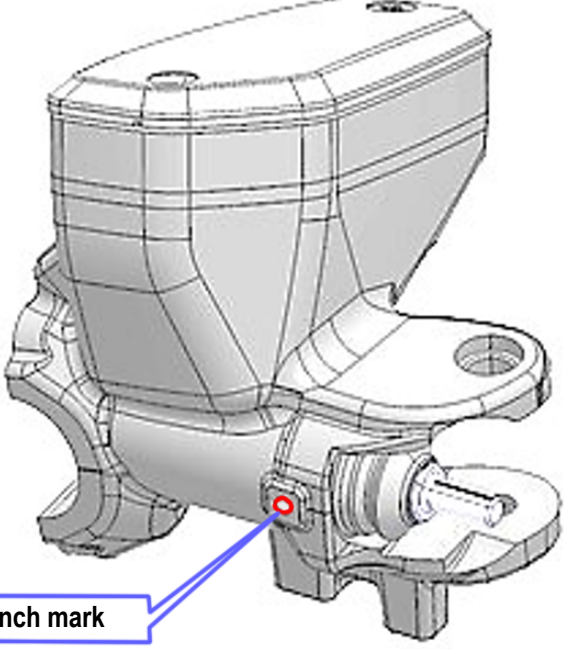
Existing (original) Parts	New (countermeasure) Parts
<ul style="list-style-type: none"><li>• 59667-23H00</li></ul>  <p data-bbox="602 894 760 926">Diaphragm</p>	<ul style="list-style-type: none"><li>• 59667-23H10-RX0</li></ul>  <p data-bbox="1284 884 1442 915">Diaphragm</p>
<ul style="list-style-type: none"><li>• 59600-10L**</li></ul>  <p data-bbox="396 1696 776 1728">Front master cylinder body</p>	<ul style="list-style-type: none"><li>• 59601-10LA0-RX0</li></ul>  <p data-bbox="1094 1696 1474 1728">Front master cylinder body</p>

**NOTICE**

Replace all the parts included in the Front Brake Master Cylinder Set, even for vehicles that have had the "GSX1300RM2 (2022 Hayabusa) Front Brake Master Cylinder Body Replacement Recall Campaign 2A99" completed.

**Warranty claim processing:**

Submit a warranty claim for each recall repair immediately upon completion. This campaign requires you to file a warranty claim using ONE of the methods described below.

**Suzuki CONNECT Short Campaign Claim:** The Short Campaign Claim will reimburse you for the Front Master Cylinder Parts Set (59600-10870-RX0), and brake fluid, plus 0.8 hour labor. Because the Short Claim will automatically add the Brake Fluid (990A0-01E91-12Z) when submitted, do not list the brake fluid on the claim.

<b>CAMPAIGN 3A04 GSX1300RM2-M4 FRONT BRAKE MASTER CYLINDER PARTS REPLACEMENT SUZUKI CONNECT SHORT FORM INSTRUCTIONS</b>	
<b>CLAIM INFORMATION:</b>	
CLAIM NUMBER:	XXXXX,X (Dealer enters number)
ENTRY TYPE:	VIN, Model/Frame or Control/Sequence # (Dealer chooses)
REPAIR DATE:	Enter date of repair
MILEAGE:	Enter mileage at repair date
CAMPAIGN NUMBER:	3A04

**Suzuki CONNECT Long Campaign Claim:** The Long Campaign Claim will reimburse you for the Front Master Cylinder Parts Set (59600-10870-RX0) plus 0.8 hour labor, and additional parts and labor as authorized by your TSPM. You will need to add the brake fluid part number (990A0-01E91-12Z) to the additional parts list.

**Reminder:**

All LONG CLAIM FORMS must be preauthorized by TECH-LINE or your dealership's Technical Service & Parts Manager (TSPM) prior to submission. Long Claim Forms submitted without a PAS number will be returned, unpaid.

<b>CAMPAIGN 3A04 GSX1300RM2-M4 FRONT BRAKE MASTER CYLINDER PARTS REPLACEMENT SUZUKI CONNECT LONG FORM INSTRUCTIONS</b>	
<b>CLAIM INFORMATION:</b>	
CLAIM NUMBER:	XXXXX,X (Dealer enters number)
ENTRY TYPE:	VIN, Model/Frame or Control/Sequence # (Dealer chooses)
REPAIR DATE:	Enter date of repair
MILEAGE:	Enter mileage at repair date
CAMPAIGN NUMBER:	3A04
LABOR TIME:	As authorized by your TSPM
<b>PARTS INFORMATION:</b>	
ADDITIONAL PARTS:	Additional parts as authorized by your TSPM
AUTHORIZATION:	Only needed if additional parts or labor claimed
<b>FAILURE DESCRIPTION:</b>	
DESCRIPTION OF DEFECT:	Front brake master cylinder parts replacement
DESCRIPTION OF REPAIR:	Performed service campaign repair per service bulletin

**ECSTAR Oil Change & Maintenance Service Check warranty claim information:**

Submit a Suzuki CONNECT regular warranty claim using the information below. This claim will reimburse your dealership for the oil change kit plus 1.5-hours labor. On the claim, use the part number of 99103-INCE1 for oil change kit reimbursement, **NOT 990A0-01E40-4KT**.

**Part:** ECSTAR R9000 Full Synthetic Oil Change  
99103-INCE1

**Labor:** 1.5-hours

Please perform the recall service promptly so your customer can take advantage of this incentive at the same time. If you have any questions, contact TECH-LINE or your TSPM.

**Important:**

The *ECSTAR Oil Change & Maintenance Service Check* is only for customers who purchased their Hayabusa before October 11, 2024. This incentive service must be completed at the same time as the 3A04 recall service. If a warranty claim is submitted for the incentive service and no corresponding claim for the recall service has been submitted, the incentive service claim will be denied. The recall and incentive service must be completed together and the claims submitted together on or before September 30, 2025, or the incentive service claim will be denied.

**CAMPAIGN 3A04 CUSTOMER INCENTIVE SERVICE  
ECSTAR Oil Change & Maintenance Service Check  
SUZUKI CONNECT CLAIM INSTRUCTIONS**

<b>CLAIM INFORMATION - REGULAR:</b>	
CLAIM NUMBER:	XXXXX,X (Dealer enters number)
ENTRY TYPE:	VIN, Model/Frame or Control/Sequence # (Dealer chooses)
REPAIR DATE:	Enter date of repair
MILEAGE:	Enter mileage at repair date
LABOR OPERATION:	AZ9999
COMPLAINT CODE:	99 OTHERS
DEFECT CODE:	A9 OTHERS (TEMPORARY)
<b>PARTS INFORMATION:</b>	
FAILED PART:	99103-INCE1
FAILURE DESCRIPTION:	
DESCRIPTION OF DEFECT:	CAMPAIGN 3A04 CUSTOMER INCENTIVE SERVICE
DESCRIPTION OF REPAIR:	CAMPAIGN 3A04 CUSTOMER INCENTIVE SERVICE

**Returning Unused Recall Campaign 2A99 Parts Kits:**

If you have unused, new condition **Front Master Cylinder Parts Set (59600-10860-RX0)** in your parts inventory, follow the parts return procedures in the *Parts Department Operations Manual*. [You can view this manual on Suzuki CONNECT.](#)

If you have any questions regarding parts returns, please contact SMO Parts Coordination at (714) 854-2165.

## FRONT BRAKE MASTER CYLINDER PARTS SET REPLACEMENT RECALL SERVICE

- Follow the repair procedure listed on the following pages to replace the front brake master cylinder parts set and the diaphragm of the front brake master cylinder assembly. You will also replenish the brake fluid and bleed any air from the brake system.



### Precautions:

- Take care to not let grease or oil (mineral oil, etc.) contaminate the brake system.
- When touching brake system components, keep your hands/work-gloves clean, and do not use tools contaminated with grease or oil (mineral oil, etc.).
- Brake fluid can damage painted surfaces, plastics and rubber materials, so do not allow the fluid to spill on any portion of the motorcycle.
- If brake fluid is spilled, flush it from the parts with water immediately.
- This brake system is filled with an ethylene glycol-based DOT 4 brake fluid.
- Do not use or mix different types of brake fluid, such as silicone-based or petroleum-based.
- Do not use any brake fluid taken from an old, used or unsealed containers.
- Never reuse brake fluid left over from a prior service or that has been stored for a long period of time.
- When replenishing brake fluid, take care to not let dust or other contaminants into the fluid.
- To avoid getting burned, do not touch the engine and exhaust system until they have cooled.
- Before the repair work, wash dirt off from the vehicle so that removed parts are kept free from dust.
- When 2 or more persons work together, pay attention to each other's safety.
- When removing parts that are to be reused, keep them arranged in an orderly manner so that they may be reinstalled in the proper order and orientation.

Refer to the Hayabusa Service Manual (99500-10L00-03E) for any details or procedures not mentioned in these instructions.

**Required tools:**

Tool or item	Size or capability
Box end wrench	8 mm
Socket wrench	8 mm, 10 mm
Hexagon wrench (Allen-wrench)	5 mm, 6 mm
Ratchet handle	(to match socket wrench)
Phillips screwdriver	Medium (#2)
Slot-style screwdriver	Large
Torque wrench	Range: 0.75 to 17.0 lb-ft or (10 to 23 N.m) or (0.10 to 2.3 kgf-m)
Fluid receptacle and clear hose for brake fluid flush	(as required)

**Required chemicals:**

Chemical	Number or quantity
Suzuki ECSTAR DOT 4 Brake Fluid	990A0-01E90-12Z, as required
Suzuki silicone grease	99000-25100, as required

**Replacement parts:**

Part Name	Part Number	Quantity	Includes
<b>PARTS SET, FR MASTER CYLINDER</b>	<b>59600-10870-RX0</b>	<b>1</b>	DIAPHRAGM, R (59667-23H10-RX0) x 1 ①
			CYLINDER SET, FRONT MASTER (59601-10LA0-RX0) x 1 ②
			NUT (08319-2106A) x 1 ③
			WASHER (09161-10009) x 2 ④

[See pages 4 and 5 for a detailed parts set diagram and identification information.](#)

## Front Brake Master Cylinder Parts Set Replacement Procedure:

Reference: GSX1300R Service Manual (99500-10L00-03E)

### Remove the Front Brake Master Cylinder:

1. Turn the ignition switch OFF.
2. Record the position of the brake lever adjuster ①.
3. Position the motorcycle on a level surface and adjust the handlebars so the front brake master cylinder is level.
4. Place a clean absorbent cloth ② underneath the master cylinder as shown in the image at right. This helps prevent brake fluid from getting on other parts if it is spilled or splashed during the repair.
5. Remove the reservoir cap screws ③, the reservoir cap ④, and the plate ⑤, and diaphragm ⑥ from the front brake master cylinder.

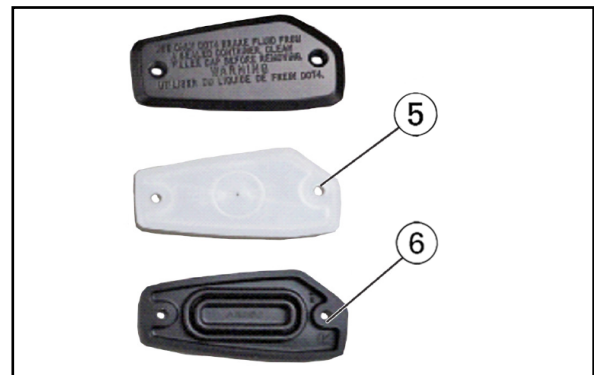
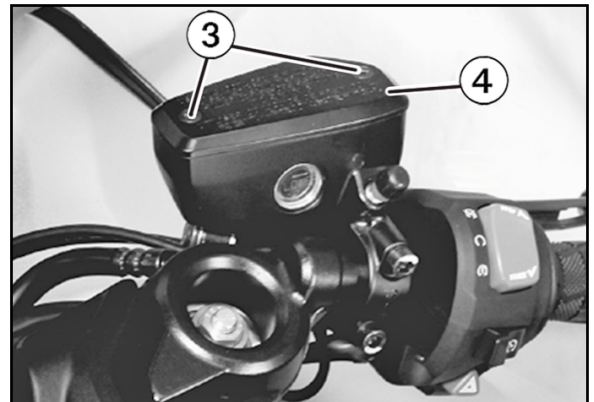
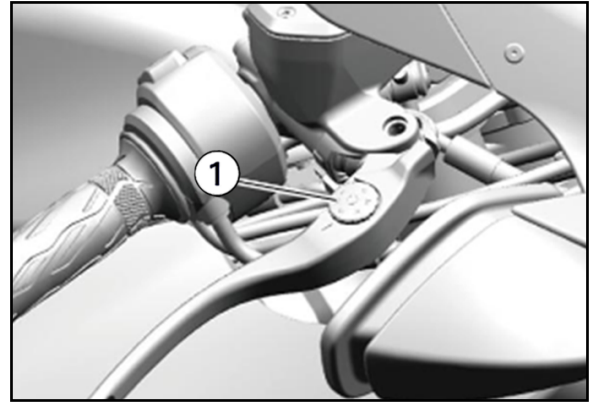

- Using a syringe or squeeze bottle, suck up as much of the brake fluid out of the reservoir as possible.

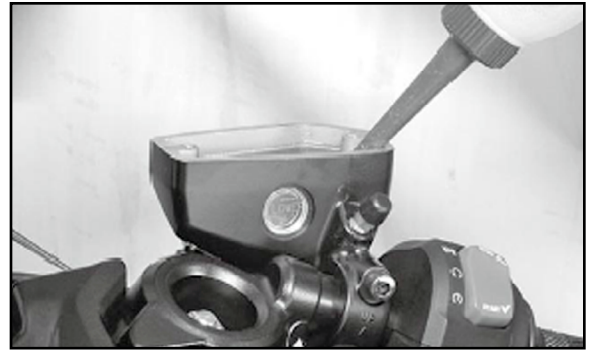

- Unscrew and remove the brake hose union bolt ① and disconnect the brake hose ② from the front brake master cylinder.

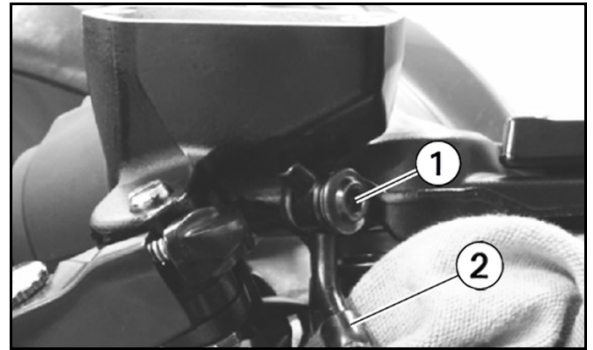

**NOTE:**

Cover the end of the disconnected brake hose with a plastic bag and tie it closed with a rubber band or twist tie to prevent brake fluid from spilling out from the brake hose.



- Disconnect the front brake light switch lead wire coupler ③ from the front brake light switch ④.

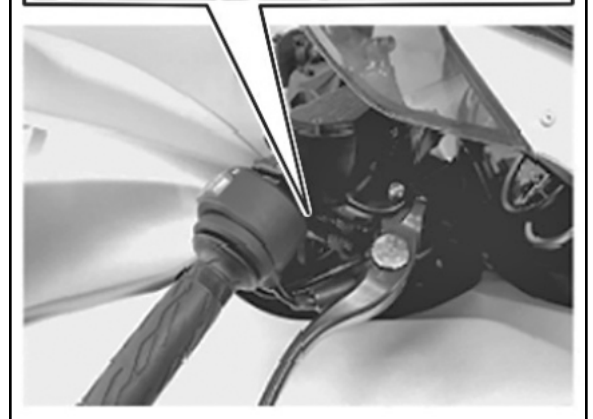
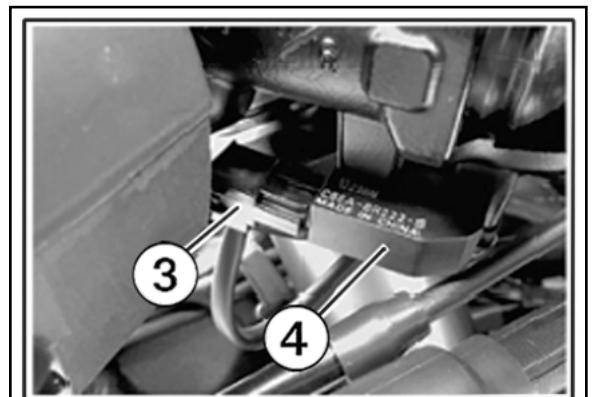

9. Remove the master cylinder holder bolts ①, and then remove the master cylinder holder (clamp) ②.

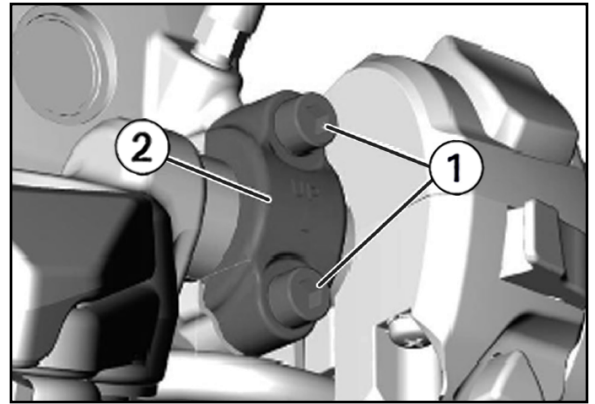

10. Remove the front brake master cylinder ③ and the front brake lever ④ as an assembly..

**NOTE:**

**When removing and handling the front brake master cylinder, take care to not spill the brake fluid still in the reservoir.**



## Replacement of the Front Brake Master Cylinder Set parts:

1. Remove the brake lever pivot lock nut ①, bolt, ②, and brake lever ③.

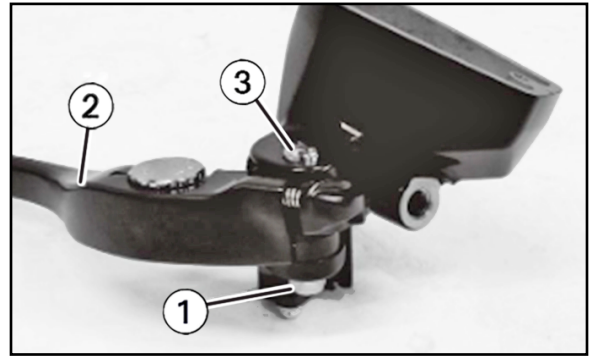

2. Remove the front brake light switch screw ④ and the front brake light switch ⑤ from the master cylinder body.

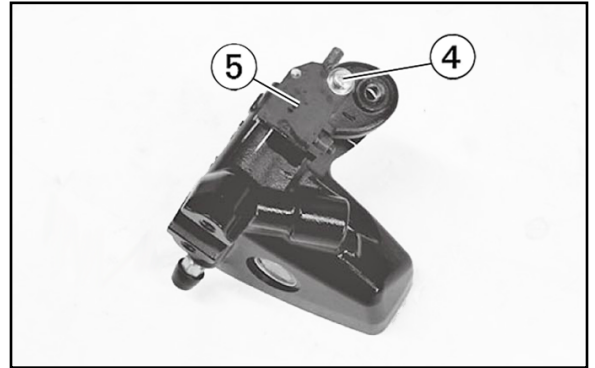

3. Align the protrusion ⑥ of front brake light switch with the hole ⑦ of the new front brake master cylinder, and then install the front brake light switch.

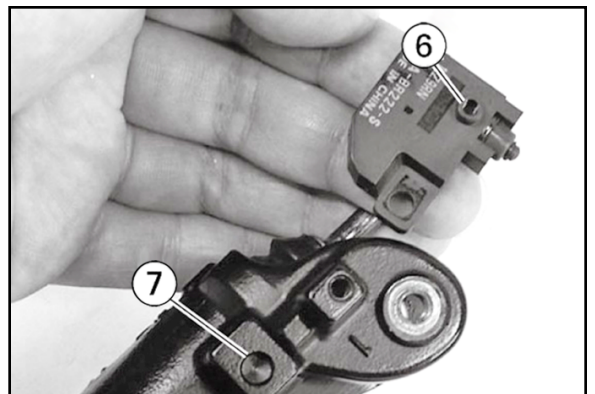

4. Tighten the front brake light switch screw ⑧ to the specified torque.

 **Tightening torque - Brake light switch screw (a):**  
**0.90 lb-ft (1.2 N.m, 0.12 kgf-m)**



5. Apply grease to the contact points "A" between push rod and brake lever.

 **Chemical:**  
**Suzuki Silicone Grease (99000-25100)**  
*(Or equivalent silicone grease generally available in your market)*

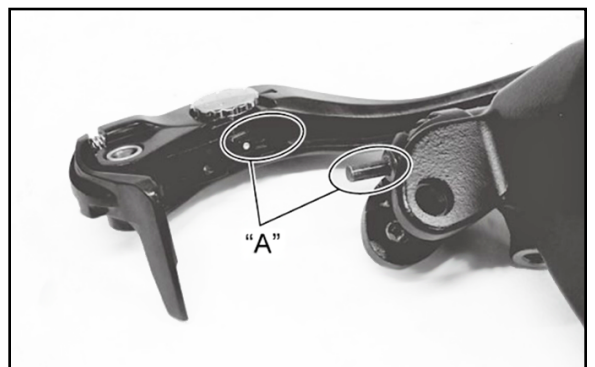

- Apply grease to the brake lever pivot bolt and front brake lever sliding surfaces "A" and install the front brake lever and brake lever pivot bolt.



**Chemical:**  
**Suzuki Silicone Grease (99000-25100)**  
*(Or equivalent silicone grease generally available in your market)*

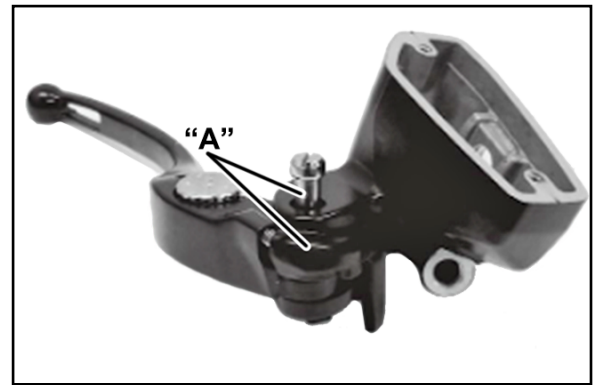

**NOTICE**

Make sure that the push rod **B** is inserted into the brake lever hole **A** in the correct position.

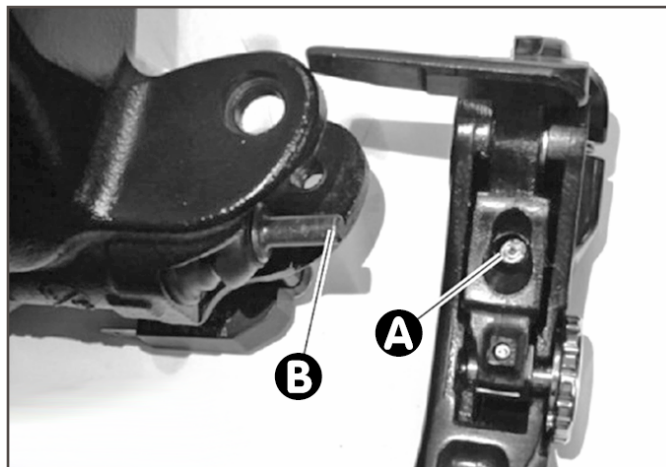

**Correct position**

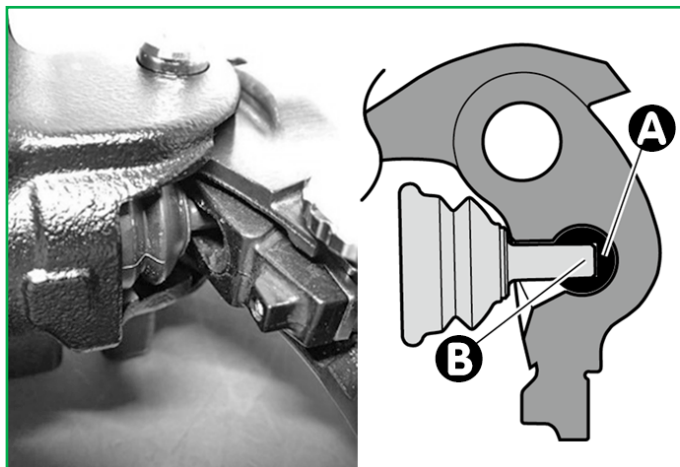

**Incorrect position**

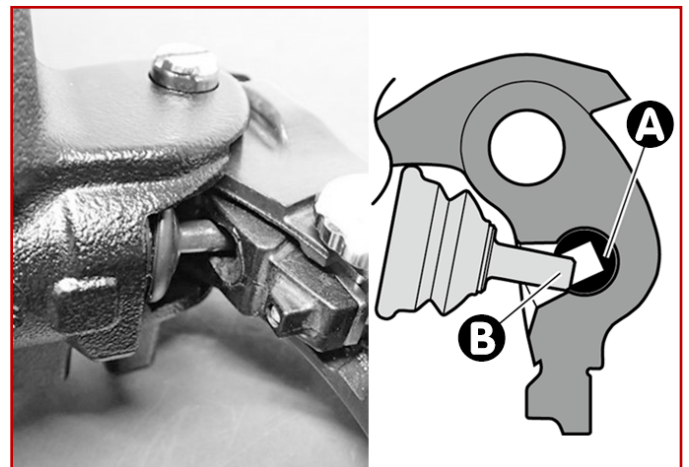

- Tighten the brake lever pivot bolt **①** and the new brake lever pivot bolt lock-nut **②** to the specified torque.



**Tightening torque - Brake lever pivot bolt (a):**  
**0.75 lb-ft (1.0 N.m, 0.10 kgf-m)**

**Brake lever pivot bolt lock-nut (b):**  
**4.35 lb-ft (5.9 N.m, 0.60 kgf-m)**

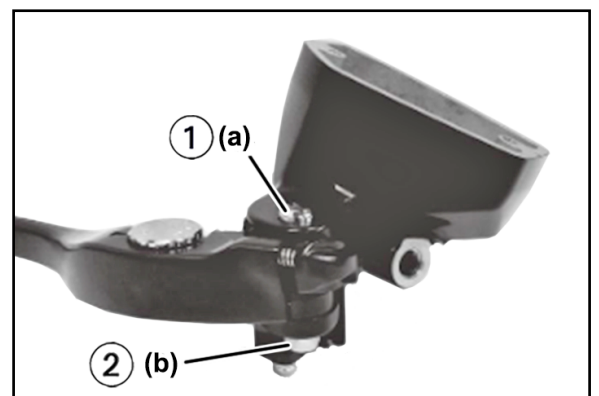

## Installation of the Front Brake Master Cylinder:

1. Install the new front brake master cylinder ① and front brake lever as an assembly onto the handlebar ②, paying attention to the following points:
  - Align the edge ③ of the master cylinder body with the punch mark ④ on the handlebar ②.
  - Tighten the upper front brake master cylinder holder bolt ⑤ to the specified torque first, and then tighten the lower bolt to the specified torque.

### NOTE:

**Orient the brake master cylinder holder ⑥ (clamp) "up" logo and arrow so they point upwards.**



**Tightening torque:**

**Front brake master cylinder holder bolt (A):**  
7.5 lb.-ft (10 N.m, 1.0 kgf-m)

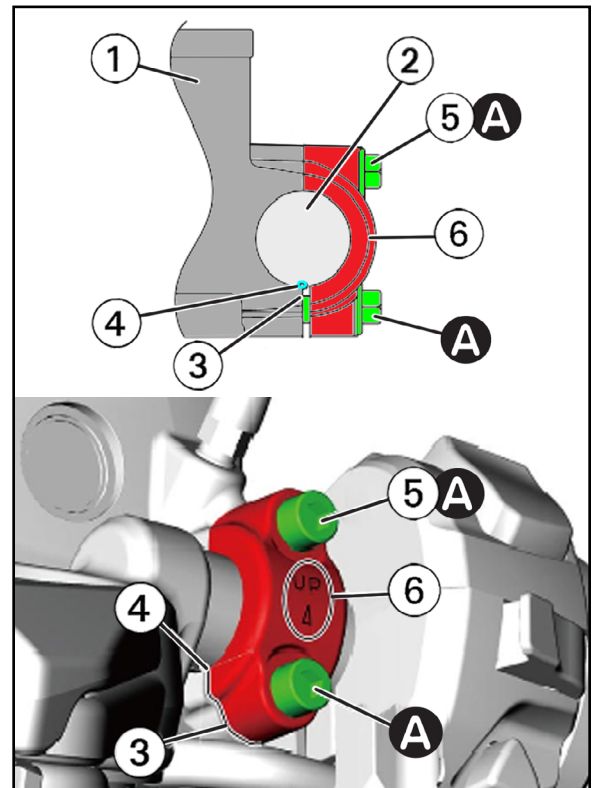

2. Connect the front brake light switch lead wire coupler ⑦ to the front brake light switch ⑧.

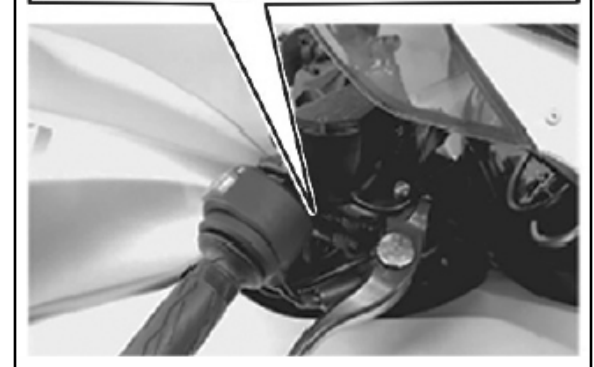
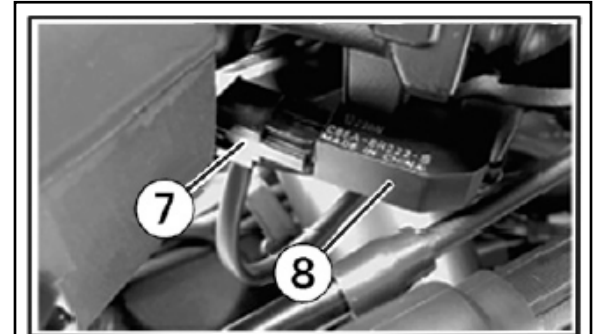

3. Install the brake hose union bolt ⑨ and new **sealing washers** ⑩ onto the brake hose ⑪.
4. Hand tighten the brake hose union bolt ⑨ to the master cylinder body and then tighten it to the specific torque.



**Tightening torque - Brake hose union bolt (a):**  
17 lb-ft (23 N.m, 2.3 kgf-m)

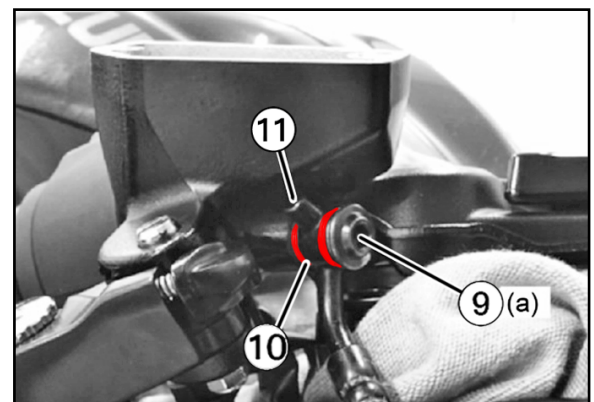

## Brake Fluid Replacement & Air Bleeding of the Front Brake:

1. Verify that the brake lever adjuster ① is set in the #3 position.

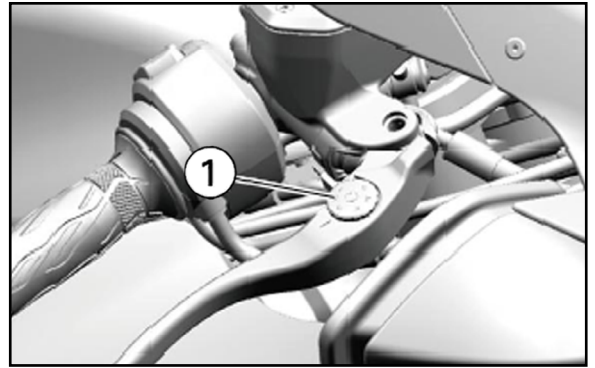

2. Fill the reservoir with brake fluid so the depth of "a" is 8 mm (0.3 in) from the reservoir tank edge.



**Chemical: Brake Fluid**  
**Suzuki ECSTAR DOT 4 (990A0-01E91-12Z)**

3. Install the reservoir cap and lightly hand thread the reservoir cap screws ② in to hold the cap in place.

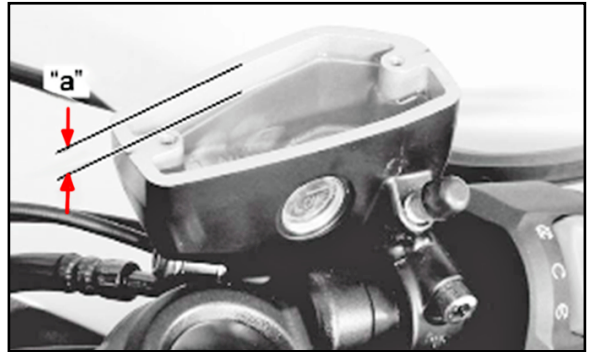

### NOTE:

Using the partially inserted screws to hold the reservoir cap in place helps prevent debris from getting into the brake fluid and reduces the chance of fluid spilling onto the motorcycle or other surfaces.

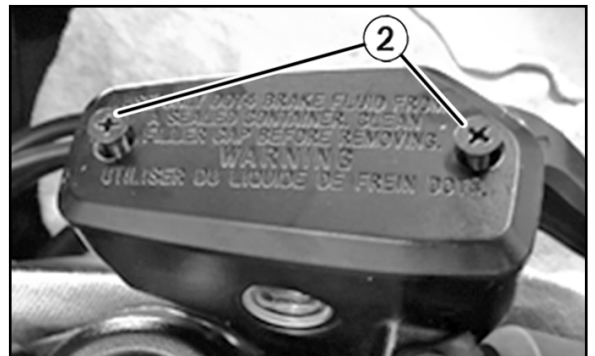

4. Attach a clear hose ③ to the front brake master cylinder air bleeder valve ④.

### NOTE:

Make sure the opposite end of the clear hose is inserted into a receptacle (to catch expelled brake fluid so it will not spill onto the motorcycle or other surfaces).

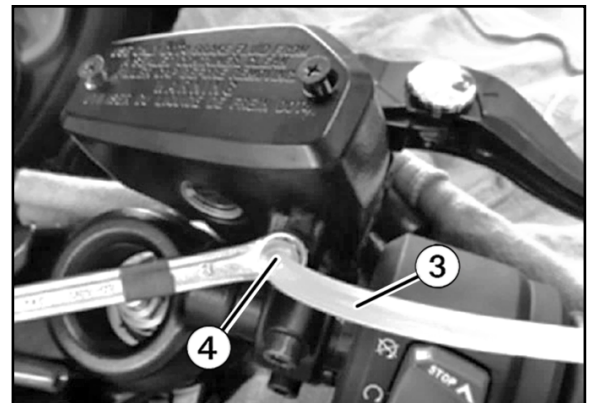

5. Squeeze the brake lever several times and, while holding the lever as close to the hand grip as possible, loosen the front brake master cylinder air bleeder valve ④ to drain the brake fluid and air into the receptacle.
6. Tighten the master cylinder air bleeder valve ④ and slowly release the brake lever.
7. Repeat steps 5 and 6 until the brake fluid is flowing out of the tube with no air bubbles present.

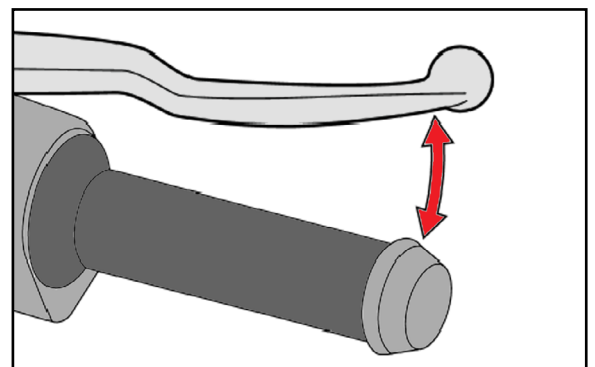

### NOTE:

While bleeding the brake system, replenish the reservoir with brake fluid as necessary to keep the fluid at the proper level "a".

8. Remove the clear hose from the front brake master cylinder air bleeder valve.
9. Tighten the front brake master cylinder air bleeder valve ① to the specified torque



**Tightening torque:**

**Front brake master cylinder air bleeder valve (a):**  
**4.45 lb-ft (6.0 N.m, 0.61 kgf-m)**

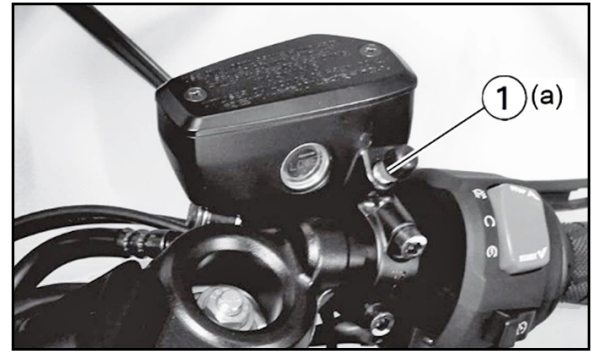

10. Attach a clear hose ② to the right front brake caliper air bleeder valve ③. Check that the opposite end of the clear hose is inserted into a receptacle to catch the brake fluid that is expelled during the bleeding process.

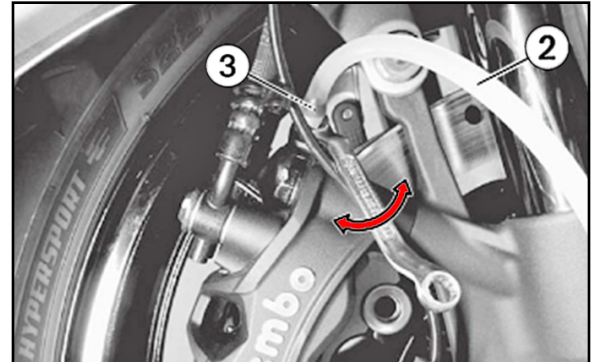

11. Remove the reservoir cap from the front brake master cylinder.
12. Fill the reservoir with brake fluid up to the depth "a" of 8 mm (0.3 in) from the reservoir tank edge.



**Chemical: Brake Fluid**  
**Suzuki ECSTAR DOT 4 (990A0-01E91-12Z)**

**NOTE:**

**While bleeding the brake system, replenish the reservoir with brake fluid as necessary to keep the fluid at the proper level "a".**

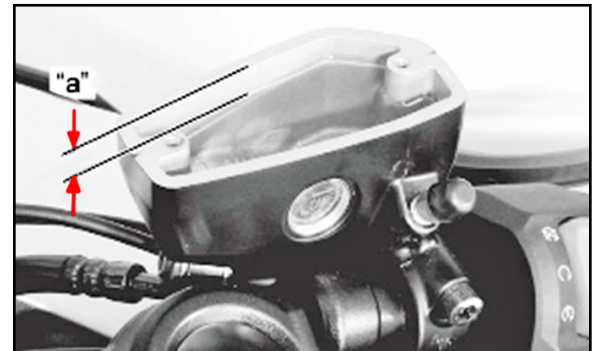

13. Install the reservoir cap ④ and lightly hand thread the reservoir cap screws ⑤ in to hold the cap in place to prevent debris from getting into the brake fluid.

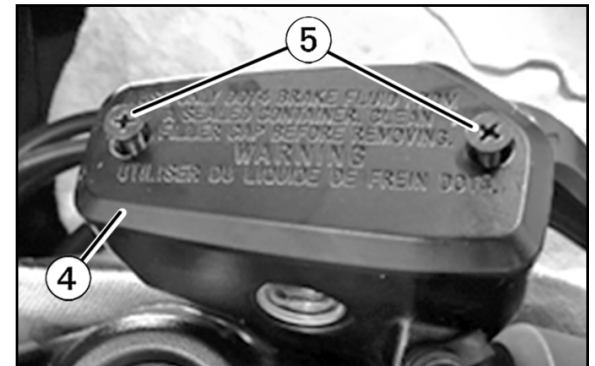

14. Loosen the right front brake caliper air bleeder and squeeze the brake lever several times until the brake fluid surface in the reservoir reaches the lower level mark. As each squeeze of the brake lever expels brake fluid into the receptacle, tighten the right front brake caliper air bleeder valve.

15. Repeat steps 11 and 12 three times (or as often as needed to bleed air from the brake fluid).

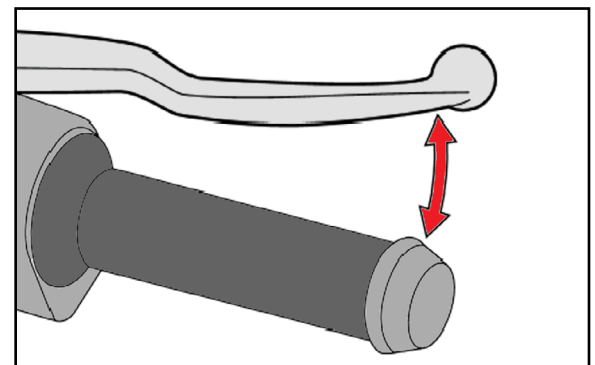

16. Remove the reservoir cap from the front brake master cylinder.
17. Fill the reservoir with brake fluid up to the depth "a" of 8 mm (0.3 in) from the reservoir tank edge.



**Chemical: Brake Fluid**  
**Suzuki ECSTAR DOT 4 (990A0-01E91-12Z)**

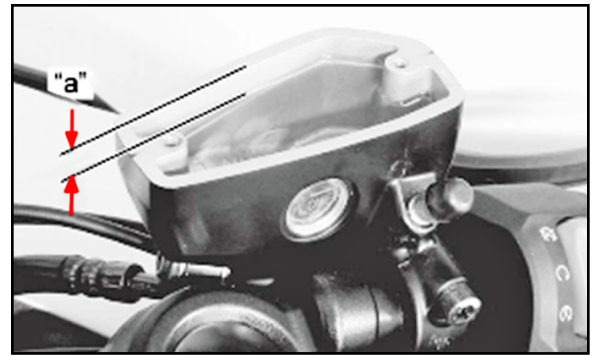

18. Install the reservoir cap ① and lightly hand thread the reservoir cap screws ② in to hold the cap in place to prevent debris from getting into the brake fluid.

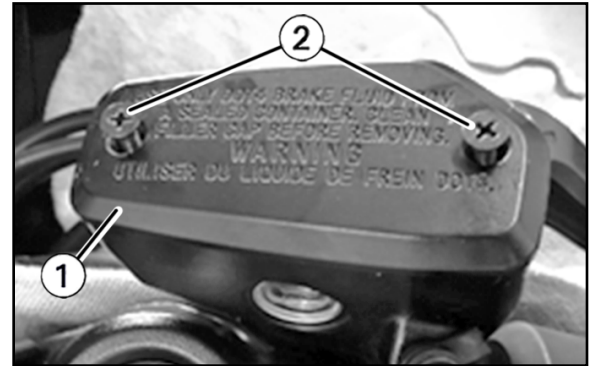

19. Squeeze the brake lever several times and, while holding the lever as close to the grip as possible, loosen the right front brake caliper air bleeder valve ③ to allow brake fluid and air bubbles to be expelled into the receptacle.
20. Tighten the front brake master cylinder air bleeder valve and release the brake lever slowly.
21. Repeat steps 19 and 20 until the brake fluid is flowing out without air bubbles.

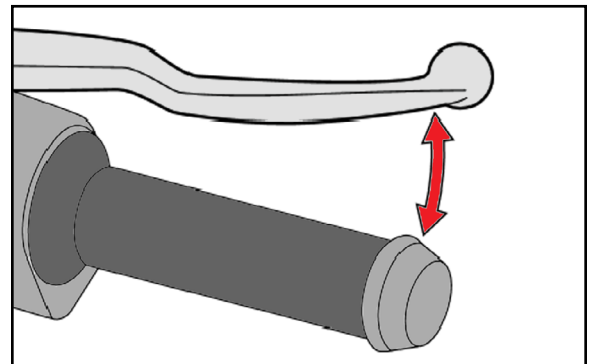

**NOTE:**

**While bleeding the brake system, replenish the reservoir with brake fluid as necessary to keep the fluid at the proper level.**

22. Remove the clear hose from the right brake caliper air bleeder valve.
23. Tighten the right brake caliper air bleeder valve ③ to the specified torque. Install the rubber cap on the air bleeder valve.

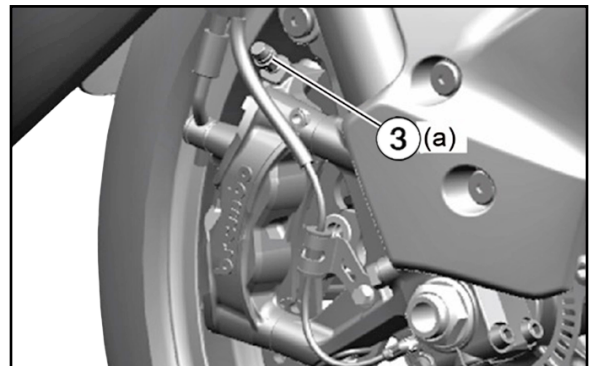

**Tightening torque:**  
**Front brake caliper air bleeder valve (a):**  
**6.3 lb-ft (8.5 N.m, 0.87 kgf-m)**

24. Repeat steps 10 to 23 on the left brake caliper ④. Bleed the fluid of any air while replenishing the brake fluid in the master cylinder reservoir.

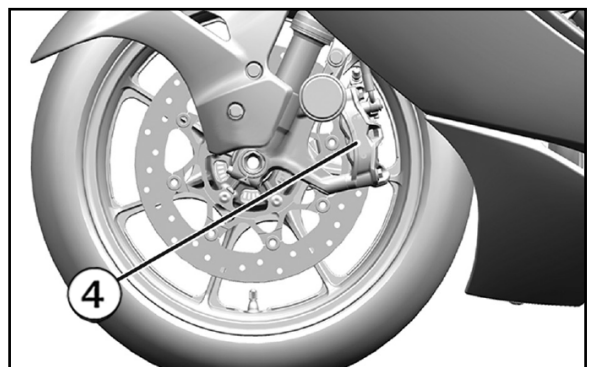

**NOTE:**

If you encounter difficulty in bleeding air from the brake system, you can use the SDS-II Diagnostic Tool and its Active Control function to cycle the ABS Control Unit. This will help bring any trapped air up to the Front Brake Master Cylinder where it can be bled out of the brake fluid.

25. Remove the reservoir cap.

26. Fill the reservoir with brake fluid up to the depth "a" of 8 mm (0.3 in) from the reservoir tank edge.



**Chemical: Brake Fluid**  
**Suzuki ECSTAR DOT 4 (990A0-01E91-12Z)**

27. Install the countermeasure rubber diaphragm ② into the plastic plate ①.

**NOTE:**

You can identify the countermeasure diaphragm by the notch ③ at the narrow end of the part. See page 4 of this bulletin for more information.

28. Install the plate ④ with the diaphragm on the front brake master cylinder.

29. Install the reservoir cap ⑤ and reservoir cap screws ⑥ to the front brake master cylinder reservoir. Tighten the reservoir cap screw to the specified torque.



**Tightening torque:**

**Brake master cylinder reservoir cap screw (a):**  
**1.1 lb-ft (1.5 N.m, 0.15 kgf-m)**

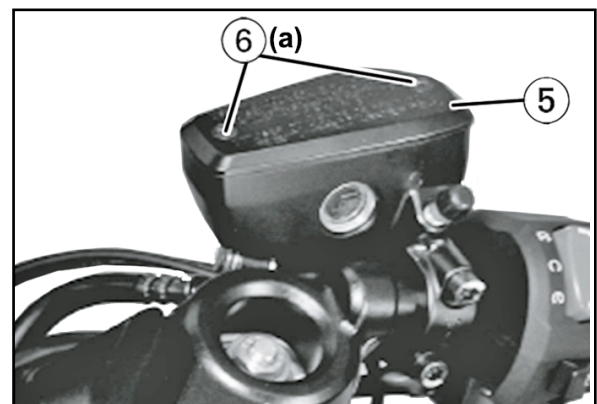
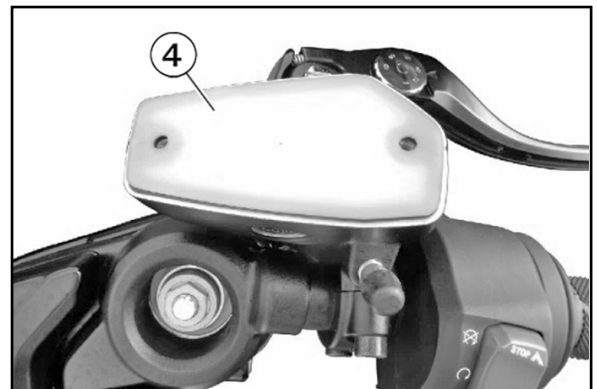
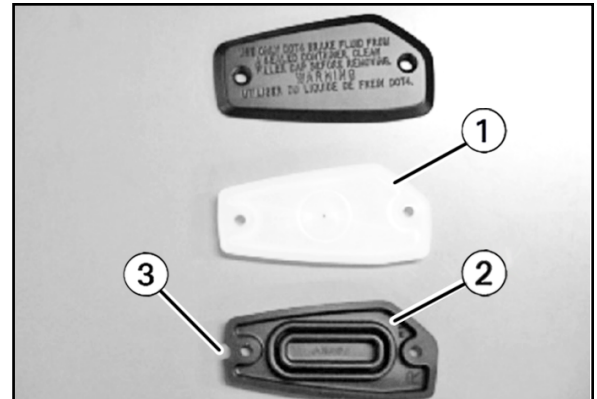
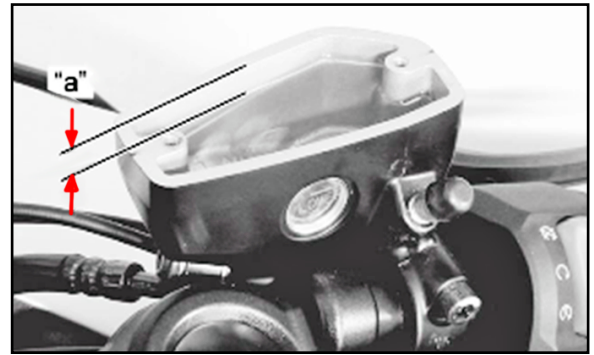

## Final check:

1. Check that each part that was serviced is set in its proper place and is securely fastened to the motorcycle.
2. Check that there is no fluid or grease residue on any part of the motorcycle (excluding components where a lubricating grease is specified).
3. If the front brake lever feels soft when you squeeze it, inspect the brake system to see if any air is trapped within the brake fluid. Resolve any issues; examine the brake fluid and bleed the air out of it until the lever action feels firm.

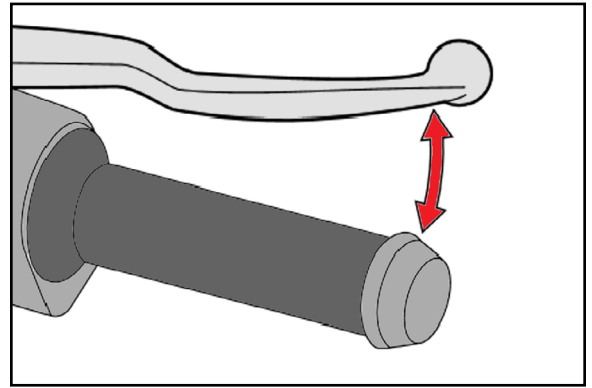

4. Verify that the brake light illuminates when you operate the front brake lever (when the ignition is switched ON). If the brake lamp does not function correctly, make sure the front brake light switch ① and its electrical coupler and properly connected. If they are, check the taillight's connection under the passenger seat.

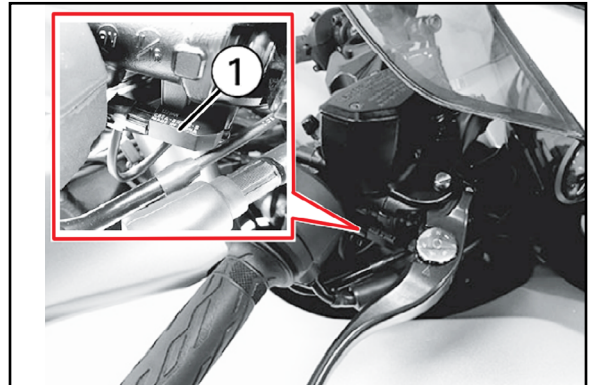

5. Reset the brake lever adjuster ② to the same position that was recorded during the recall service ([page 10, step 1](#)).
6. Test ride the motorcycle on a dry, paved road and operate the front brake to make sure is braking performance is proper. During the test ride, watch for any abnormal operation and listen for any unusual sounds and resolve them before returning the motorcycle to the customer.
7. Clean the motorcycle with special attention to areas where the recall service was performed. When delivering the motorcycle to the customer, explain the recall service and thank them for their patience.

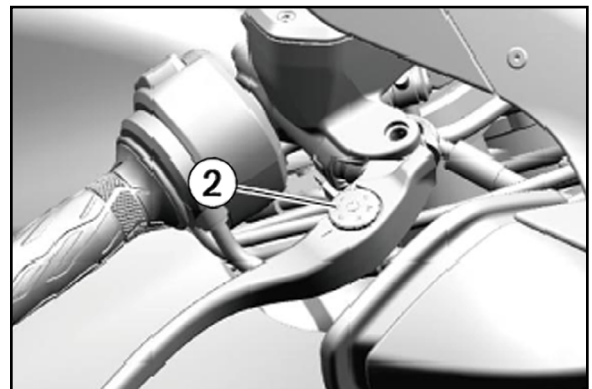

---

If you have any questions related to this recall service, please call TECH-LINE at (714) 996-7480 or contact your Technical Service & Parts Manager (TSPM).

Thank you for your attention to this recall service,

The Suzuki Service Department

**SALES**



Motorcycle / ATV

Bulletin No. 24-097

Date: October 11, 2024

## **IMPORTANT SAFETY RECALL STOP RETAIL SALES & DELIVERY**

**Suzuki Motor Corporation has determined that a safety defect exists in 2022 – 2024 Hayabusa (GSX1300R\_M2 – M4) models:**

Model	Spec.	V.I.N. Range
GSX1300RRM2/M3/M4	E03	JS1EJ11B#N7100001 - JS1EJ11B#R7101566
	E33	JS1EJ11D#N7100001 - JS1EJ11D#R7100320

This notice is sent to you in accordance with the requirements of the National Traffic and Motor Vehicle Safety Act.

Suzuki Motor Corporation is initiating a safety recall campaign to replace the front brake master cylinder and related parts. **Do not sell or deliver any new or used, affected Hayabusa motorcycles until this Front Brake Master Cylinder Parts Set Replacement recall service has been completed.**

**Service Bulletin & Safety Recall Repair:**

Information about performing the Front Brake Master Cylinder Parts Set Replacement recall service will be provided in a Service Bulletin that will be posted to Suzuki CONNECT in the coming weeks.

**Recall Campaign 3A04:**

This recall campaign 3A04 supersedes the previous campaign 2A99 for the Front Brake Master Cylinder Body ([Service Bulletin GS/GSX/GSX-R No. 259](#)). Therefore, you are required to perform recall 3A04 for the units which you have already completed the PREVIOUS 2A99 recall campaign. However, you should not perform the PREVIOUS 2A99 recall campaign if it has not yet been completed.

**Parts Availability & Ordering:**

Suzuki Motor USA, LLC (SMO) will provide additional information regarding recall service parts availability and ordering in the Service Bulletin mentioned above.

**Customer Notification Letters:**

SMO expects to notify retail customers of this safety recall beginning the week of October 25, 2024. A copy of the customer notification letter will be included in the Service Bulletin.

**Hayabusa models that require the Recall Service:**

This recall affects all 2022 (M2) through 2024 (M4) Hayabusa models.

*Continued on the following page >>*

Motorcycle / ATV

Bulletin No. 24-097

Date: October 11, 2024

**Consequences of Non-Compliance:**

**ALL NEW SUZUKI VEHICLES IN DEALER INVENTORY THAT ARE SUBJECT TO A RECALL OR CUSTOMER SATISFACTION CAMPAIGN INITIATED BY SMO MUST BE REPAIRED BEFORE THESE VEHICLES ARE SOLD OR DELIVERED BY THE DEALER TO THE RETAIL CUSTOMER. FAILURE TO DO SO IS A VIOLATION OF FEDERAL LAW, THE SUZUKI POWERSPORTS DEALER SALES AND SERVICE AGREEMENT (THE "DEALER AGREEMENT"), AND SMO'S SALES POLICY REGARDING FACTORY SAFETY RECALL OR SAFETY MODIFICATION PROGRAMS (THE "POLICY"). A COPY OF THE POLICY IS AVAILABLE ON SUZUKI CONNECT FOR YOUR REFERENCE.**

**FURTHER, FAILURE TO COMPLY WITH THE INSTRUCTIONS OF SMO REGARDING COMPLIANCE WITH RECALLS OR OTHER SAFETY OR PRODUCT IMPROVEMENT CAMPAIGNS OR PROGRAMS, AND/OR FAILURE TO MAKE A GOOD FAITH EFFORT TO COMPLY WITH THE FEDERAL CLEAN AIR ACT, THE NATIONAL TRAFFIC AND MOTOR VEHICLE SAFETY ACT, THE CONSUMER PRODUCT SAFETY ACT, OR ANY OTHER LAWS, ORDERS, RULES, OR REGULATIONS REGARDING RECALLS OR OTHER SAFETY OR PRODUCT IMPROVEMENT CAMPAIGNS OR PROGRAMS CONSTITUTES A BREACH OF THE DEALER AGREEMENT AND IS A VIOLATION OF SMO POLICY REFERENCED ABOVE. A DEALER MAY BE HELD RESPONSIBLE FOR ANY PRODUCT DAMAGE AND/OR PERSONAL INJURIES RESULTING FROM SUCH FAILURE.**

If you need any additional information, please contact the Suzuki TECH-LINE (at 714-996-7480) or your Technical Service & Parts Manager. We apologize for this inconvenience and will do everything possible to resolve this situation as quickly as possible.

Thank you for your continued support and understanding.



Chris Coons  
Senior Manager, Motorcycle Sales Planning and Administration



Suzuki Recall #3A04  
NHTSA Recall #24V769

## IMPORTANT SAFETY RECALL

### This Notice Applies to Your Suzuki Hayabusa Motorcycle

March 7, 2025

Dear Suzuki Owner:

This notice is sent to you in accordance with the requirements of the National Traffic and Motor Vehicle Safety Act.

Suzuki Motor Corporation has decided that a defect which relates to motor vehicle safety exists in certain 2022 through 2024 Hayabusa (GSX1300RM2-M4) motorcycles. According to our records, you own one of the motorcycles affected by this recall.

#### What is the problem?

The front brake master cylinder reservoir cap diaphragm contains an additive that can affect the brake fluid and cause rubber parts inside the master cylinder to swell. If this occurs, proper brake fluid pressure may be affected, and the brake lever may require greater than normal travel in a subsequent application of the front brake. This can lead to extended stopping distances, increasing the risk of a crash.

#### What is Suzuki doing to solve the problem?

Under recall campaign 3A04, your Suzuki dealer will replace the affected front brake master cylinder parts with new parts. The new parts include a master cylinder body, and a reservoir cap diaphragm manufactured with an updated material that will not cause swelling of the master cylinder rubber parts. The repair will take approximately one hour to perform, and there will be no charge to you for any recall-related parts or labor.

Recall campaign 3A04 supersedes the previous 2A99 campaign for the Front Brake Master Cylinder recall on the 2022 Hayabusa (GSX1300RM2) models. Even if your Hayabusa had recall 2A99 performed, you must still have this new 3A04 campaign performed on your motorcycle. If your Hayabusa never had the 2A99 recall performed, it will only require completion of the new 3A04 recall service.

Suzuki is sensitive to the inconvenience this recall campaign is to you, so for a limited time (until March 31, 2025) you can receive a ECSTAR Oil Change & Maintenance Service Check\* on your Hayabusa as your dealer performs the 3A04 recall service. There is no cost to you for the service check's parts or labor. A Genuine Suzuki oil filter and ECSTAR R9000 Full Synthetic Oil will be used. Please mention your desire to have this free service performed on your Hayabusa when you speak to your dealer about the recall service appointment.

Suzuki is offering round-trip towing reimbursement, but please note the following: You are responsible for arranging for your motorcycle to be towed to and from the repairing dealer using a professional motorcycle towing service or the repairing dealer. These towing expenses are reimbursable, for which you must provide a receipt for the towing services provided, as well as the completed recall repair order. Please contact Suzuki Customer Relations at (714) 572-1490 for approval before contracting with a towing service.

#### **Restrictions and Limitations**

- The reimbursement is applicable only for towing services directly related to recall repairs completed no later than December 31, 2025.
- Reimbursement requests must be submitted within 30 days of service completion.
- Only expenses up to \$300 will be reimbursed for round-trip towing, unless written approval is obtained in advance from Suzuki Motor USA, LLC.

\* ECSTAR Oil Change & Maintenance Service Check is only available in the continental United States.

#### What you should do:

To expedite the recall repair, set an appointment with your authorized Suzuki dealer who will then order the necessary parts, so they are at the dealership when you bring your motorcycle in for the repair. While the actual repair takes about one hour to perform (about two and a half hours if the ECSTAR Oil Change & Maintenance Service Check is also performed), please allow for additional time processing paperwork with the dealer when you drop off and then pick up your motorcycle following the repair.

Before the recall repair is performed, Suzuki recommends the following:

1/2

Suzuki Motor USA, LLC P.O. Box 1100, Brea, CA 92822

## CUSTOMER NOTIFICATION LETTER (page 2 of 2)

- Minimize riding your motorcycle until the recall has been completed.
- If you choose to ride, please follow the following instructions:
  - ✓ Using the check list on page 3-7 of your Hayabusa's Owner's Manual, verify that the front brake lever play is not excessive, and there is no "sponginess" at the lever, and its operation is smooth.
  - ✓ If the brake lever play is normal and feels firm when you squeeze the lever you can ride your motorcycle with caution; allow additional distance for braking.
  - ✓ If the brake lever play is excessive or you feel "sponginess" when you squeeze the lever, squeeze the lever fully 2 or 3 times to see if the lever play and feel return to normal. If it does, you can ride your motorcycle with caution; allow additional distance for braking.
  - ✓ If the brake lever play remains excessive and there is "sponginess" when you squeeze the lever, contact your Suzuki dealer to discuss how to bring the motorcycle to the dealership for the recall repair.

### **What to do if you receive this notice in error:**

This notice was mailed to you according to the latest information that is available to us. If you no longer own the motorcycle described in this notice, please complete, and return the attached Change of Address/Ownership card to Suzuki Motor USA, LLC and forward this recall information to the current owner (if known). If you are the lessor of this vehicle, please forward a copy of this notice to the lessee within ten days to comply with federal regulations.

### **Customer reimbursement for repairs before this Safety Recall Notification:**

If your motorcycle is included in this recall and you have paid for repairs to address the defect that led to this recall, you may be eligible for full or partial reimbursement. Please note the following conditions for reimbursement:

Only repairs made to address the defect that led to this recall are reimbursable. Additional expenses such as towing, car rental, accommodations, damage repairs, etc., will not be reimbursed. Reimbursement will not be provided for routine scheduled maintenance. Reimbursement may be limited to the suggested list price for parts, the Suzuki published flat-rate time allowance for the repair, and the labor rate that an authorized Suzuki dealer in the same area would charge for the same repair.

Reimbursement claims may also be excluded when the claimant does not submit adequate documentation. This includes a proof of ownership, a repair order, and proof of payment for the repair.

### **Who to contact if you experience problems:**

Your Suzuki dealer can provide you the fastest response to your questions or concerns about this safety recall campaign. If you have any difficulty with this recall campaign, you may contact Suzuki's U.S. Customer Service Department for assistance at (714) 572-1490 during the hours of 7:30 AM to 4:30 PM Pacific Time. Please have your vehicle identification number (VIN) ready when calling.

If you need to locate your nearest Suzuki dealer, please visit [www.suzukicycles.com](http://www.suzukicycles.com), click on OWNERS, scroll to the bottom of the page to the RESOURCES list and select [Find a Dealer](#). On the Find a Dealer page enter your zip code and select Submit.

If you believe that Suzuki has failed to provide the safety recall campaign service without charge or is unable to do so within a reasonable time, you may submit a complaint to the Administrator of the National Highway Traffic Safety Administration, 1200 New Jersey Ave., S.E., Washington D.C., 20590 or call the toll-free Vehicle Safety Hotline at 1-888-327-4236 (TTY: 1-888-424-9153) or go to [www.nhtsa.gov](http://www.nhtsa.gov).

We apologize for any inconvenience this recall campaign causes you. We hope you understand that your safety and satisfaction are important priorities for us.

We sincerely regret any inconvenience this Important Safety Recall may cause, but we are certain you understand our interest in your safety and your continued satisfaction with your Suzuki Hayabusa motorcycle.

Sincerely,

Suzuki Motor USA, LLC.

# ECSTAR OIL CHANGE & MAINTENANCE SERVICE CHECKLIST



## ***ECSTAR Oil Change & Maintenance Service Check List***

Customer name & date	
Dealer name & Suzuki number	

Customer address, phone & email	
VIN, mileage & notes	

Suzuki CONNECT Vehicle Master, Open Recall or Campaign

Open Recall/Campaign
Notes

SDS-II inspection, Past/Present DTCs

DTCs:
Notes

Inspection Items	OKAY?	Needs Attention	Notes
Headlight High/Low-beam operation			
Running light operation			
Taillight operation			
Brake front lever stop light operation			
Brake rear pedal stop light operation			
Turn signal operation: Right / Left			
Horn operation			
Drive chain slack			
Front tire pressure			
Front tire tread depth			
Rear tire pressure			
Rear tire tread depth			
Rear brake fluid level			
Rear brake fluid condition			
Rear brake pad thickness			
Front brake fluid level			
Front brake fluid condition			
Front brake pad thickness			
Coolant level			
Coolant condition			
Fork seal condition (leaks/no leaks)			
Steering (smooth movement, binding or notchy movement)			
Engine oil condition			
Engine fluid leaks (leaks / no leaks)			
Exhaust (mounting bolts, leaks)			
Battery voltage & load test			
Body panel fasteners			
Safety bolts (see maintenance schedule)			

Technician name & date	
------------------------	--