

Safety Recall: 2023–24 Accord High Pressure Fuel Pump Leak

APPLIES TO

Year	Model	Trim Level	VIN Range
2023–24	Accord	ALL	Check iN VIN status for eligibility.

REVISION SUMMARY

- Under Idle Test Procedure, Step 1 was added.
- Under Idle Test Procedure, Step 29 was added.
- Under Step 11 of Test the High-Pressure Fuel Pump for Hydrocarbons, a step was added to the Retest Procedure.

BACKGROUND

American Honda is announcing a **STOP SALE** and **safety recall** for certain model year 2023–24 Accord vehicles which may have improperly manufactured high-pressure fuel pumps.

A high-pressure fuel pump which was manufactured improperly can cause the fuel pump to fracture, leading to a fuel leak. A fuel leak in the presence of an ignition source may increase the risk of a fire or injury.

If this bulletin appears during an iN VIN status inquiry, the vehicle is subject to a **safety recall**. Any affected vehicles in your dealer inventory are on **STOP SALE** until further notice. Refrain from calling Tech Line for updates.

CUSTOMER NOTIFICATION

Owners of affected vehicles will be sent a notification of this safety recall. Do an iN VIN status inquiry to verify eligibility. Some vehicles affected by this campaign may be in your new or used vehicle inventory.

Failure to repair a vehicle subject to a recall or campaign may subject your dealership to claims or lawsuits from the customer or anyone else harmed as a result of such failure. To see if a vehicle in inventory is affected by this safety recall, do a VIN status inquiry before selling it.

If this bulletin appears during an iN VIN status inquiry, the vehicle is subject to a safety recall. Any affected vehicles in your dealer inventory are on STOP SALE until further notice. Refrain from calling Tech Line for updates.

An inspection procedure is available in the INSPECTION PROCEDURE section. Should the vehicle fail the inspection, the repair will not be complete until it receives a replacement high-pressure fuel pump. The following suggested text should be included on any customer repair order for an already sold affected vehicle that comes in for service and fails the inspection. This information should be printed out completely and provided to the customer any time service is conducted on an affected vehicle, and the recall repair has not yet been completed. Once parts are available, the normal procedures under the Service Operation Manual (SOM) 7.2.1 will apply for this recall.

CUSTOMER INFORMATION: The information in this bulletin is intended for use only by skilled technicians who have the proper tools, equipment, and training to correctly and safely maintain your vehicle. These procedures should not be attempted by “do-it-yourselfers,” and you should not assume this bulletin applies to your vehicle, or that your vehicle has the condition described. To determine whether this information applies, contact an authorized Honda automobile dealer.

Suggested Verbiage to be Included on the Repair Order

Customer was advised that:

The vehicle is subject to a recall affecting the high-pressure fuel pump. The inspection process has determined the pump has a leak. However, the parts necessary to complete the repair are currently unavailable. Vehicles with a leaking high-pressure fuel pump will be held until parts are available, and a loaner vehicle will be provided. Vehicles are eligible for immediate repair once parts are available, and the dealer will notify the customer.

CORRECTIVE ACTION

- **Vehicles fewer than 700 miles:** Check the 12-volt battery, perform the idle test procedure, then test the high-pressure fuel pump for a leak. Replace the high-pressure fuel pump if a leak is detected.
- **Vehicles 700 or more miles:** Test the high-pressure fuel pump for a leak. Replace the high-pressure fuel pump if a leak is detected.

WARRANTY CLAIM INFORMATION

Vehicles with 700 or More Miles

NOTE:

- For templates A, B, or C, the odometer must read **700 or more miles**.
- For template C, open a **second repair line** for the fuel pump replacement.

Operation Number	Description	Flat Rate Time	Defect Code	Symptom Code	Template ID	Failed Part Number
1215A7	Inspect high pressure fuel pump for hydrocarbons. NO LEAK FOUND. No further action required.	0.4 hr	6YP00	MK700	A24123A	16790-6NA-A01
1215A8	Inspect high pressure fuel pump for hydrocarbons. HPF PUMP IS LEAKING	0.4 hr	6YP00	MK700	A24123B	16790-6NA-A01
1211PC	Replace high pressure fuel pump	1.2 hr	6YP00	MK700	A24123C	16790-6NA-A01

Vehicles with fewer Than 700 Miles

NOTE:

- For templates D, E or F odometer must read **fewer than 700 miles**.
- For template F, open a **second repair line** for the fuel pump replacement
- After completion of the idle test, a warranty code will be generated. Please clearly note the warranty code on the repair order. When submitting a claim enter the code in the test code field of the claim form. To retrieve a warranty code, go through Honda Diagnostic Cloud Website select AHM SSO and use your log in credentials.
- The gasoline consumed during the idle test procedure, under the inspection procedure, can be claimed up to \$25. Enter the amount under templates D or E, and sublet code O1.

Operation Number	Description	Flat Rate Time	Defect Code	Symptom Code	Template ID	Failed Part Number
1215B0	Do idle test procedure then test for hydrocarbons. NO LEAK FOUND. No further action required.	1.0 hr	6YP00	MK700	A24123D	16790-6NA-A01

1215B1	Do idle test procedure then test for hydrocarbons. HIGH PRESSURE FUEL PUMP IS LEAKING	1.0 hr	6YP00	MK700	A24123E	16790-6NA-A01
1211PD	Replace high pressure fuel pump	1.2 hr	6YP00	MK700	A24123F	16790-6NA-A01

PARTS INFORMATION

Parts required for this repair will be made available as the part's supply improves. Please contact the dealership's DPSM for further questions.

NOTE: The affected volume of vehicles is expected to be low.

Part Name	Part Number	Quantity
High Pressure Fuel Pump Assy. Service Kit	06161-6NA-305	1

REQUIRED MATERIALS

NONE

TOOL INFORMATION

Tool Name	Tool Number	Quantity
Hydrocarbon Tester and Caps (3)	07AAJ-001A100	1
Honda Antares Capsule	BSEHAC001	1

INSPECTION PROCEDURE

- If the vehicle has **700 or more miles**, test for hydrocarbons at the high-pressure fuel pump. If it fails the test criteria, replace the high-pressure fuel pump.
- If the vehicle has **fewer than 700 miles**, do the Idle Test procedure, then test for hydrocarbons at the high-pressure fuel pump. If it fails the test criteria, replace the high-pressure fuel pump.

Important Notice

⚠ WARNING

Carbon monoxide gas is toxic and can rapidly accumulate in closed or even partly enclosed areas. Breathing in carbon monoxide gas can cause unconsciousness and even death. **Never** leave the vehicle on while parked in a garage or other areas with limited ventilation!

- A fuel leak in the presence of an ignition source may ignite and cause a fire.
- Verify the vehicle is in PARK prior to conducting the INSPECTION PROCEDURE.
- Leaving the key in the vehicle may result in the theft or other accidental movement of the vehicle. Make sure the key is in a safe location for **any** period during which the observation period of the INSPECTION PROCEDURE is conducted.
- Vehicles should be idled during the INSPECTION PROCEDURE in an open area, away from occupied locations and structures while still under the supervision of appropriate dealership personnel. The vehicle should be assessed at regular intervals to confirm correct operation. **Failure to do so** may result in the theft, and/or other damages to the vehicle as well as harm to individuals.
- Dealerships must comply with all other applicable laws and regulations whether federal, state, or local before and during completion of both the INSPECTION PROCEDURE and REPAIR PROCEDURE.

For vehicles with 700 or more miles, go to [Test the High-Pressure Fuel Pump for Hydrocarbons](#).

Idle Test Procedure (For vehicles with fewer than 700 miles)

1. **Confirm the 12-volt battery is in good condition, see October 2024 Honda Service News [Long-Term Maintenance and Care for Vehicles in Dealer Inventory](#).**
2. Start the engine.
3. Make sure the A/C is turned OFF to prevent the radiator fan from running.
4. With the engine running, visually check the solenoid area of the high-pressure fuel pump for fuel leakage.

Is fuel leakage visible?

Yes – 1. Turn the vehicle to OFF mode.

2. Go to **step 11** of the [Test the High-Pressure Fuel Pump for Hydrocarbon](#) section and scan the QR code to order a replacement high-pressure fuel pump (No further testing required).

No – Proceed to the next step.



Look for leaks in this area.

5. Turn the vehicle to the OFF mode.
6. Read through the entire procedure fully before continuing with the inspection procedure.
7. Connect the Honda Antares Capsule (HAC) to the data link connector (DLC).

NOTE:

- Make sure your Honda Antares Capsule is registered and configured for Wi-Fi or mobile hotspot. Click here for more information: [Honda Antares Capsule Registration and Configuration](#) quick start guide.
- **Do not** use the USB cable from the capsule for this test.
- Technical assistance for the Honda Antares Capsule (HAC) and i-HDS related applications is provided by the American Honda Special Tools Hotline at 1-833-949-4672.
Hours of operation are Monday to Friday, 7 AM to 5 PM Pacific Time.

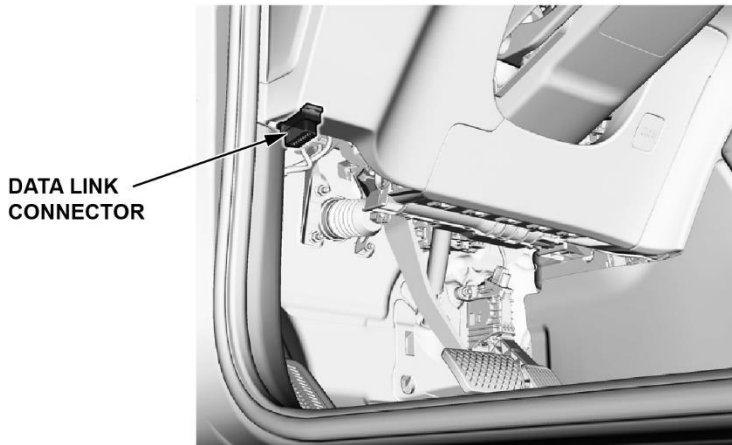

8. Start the engine.
9. Launch the Honda Diagnostic Cloud (HDC) website – <https://hondadiagnostics.com>
10. Select US Dealer.
11. Login using iN credentials.
12. On the Connected Vehicles screen, in the VCI ID column, find the serial number for the HAC you will be using, and click to select.
13. Change the HAC VCI mode from Diagnostic Mode to Campaign Mode by clicking on the Toggle VCI Mode button.

NOTE:

- Campaign mode is for this procedure only. **For all other uses**, switch back to Diagnostic Mode by clicking the Toggle VCI Mode button.
- Tip: The Launch HPFP App button will only appear when you select a HAC configured for Campaign mode.

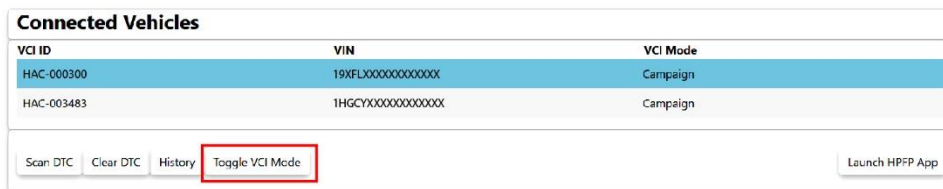

14. Click on the Launch HPFP App button.

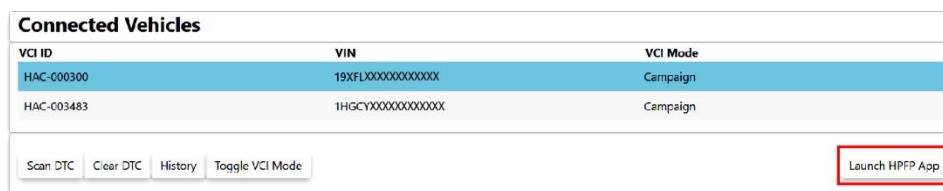

15. From the HP Fuel Pump Leak Pretest screen, select the Start New Pretest button

HP Fuel Pump Leak Pretest

This pretest procedure is completed in 3 steps :

1. Precondition the vehicle and let the engine idle for up to 13 hours
2. Return to confirm completion of engine idle phase
3. Prepare engine for Fuel Pump Leak Test

Before proceeding, your Honda Antares Capsule must be:

- Connected to the vehicle's DLC port
- Connected to your dealer's Wi-Fi network or mobile hotspot
- Configured for "Campaign Mode" on HDC

Select an option to continue :

Start New Pretest

Resume / Finish / Confirm Pretest

16. Confirm the Honda Antares Capsule ID, VIN, and Vehicle are correct, then click Next.

NOTE: If the VIN is not part of this campaign or the odometer value exceeds the test parameters, you will receive a notification.

HAC and VIN

Honda Antares Capsule ID:	HAC-000300
VIN :	19XFLXXXXXXXXXX
Vehicle:	2025 Honda CIVIC HYBRID

Back

Next

17. Prepare the vehicle for the test:

1. Ensure the fuel level is above 50%, but do NOT top off the tank.
2. Confirm the hood is completely closed and latched.
3. Confirm the engine is running.
4. Driver's seat belt is buckled.

VIN: 1HGCVXXXXXXXXXX
Vehicle: 2023 HONDA ACCORD

Preconditions :

1. Ensure the fuel level is above 50% to allow a runtime of **10 hours**
2. Confirm the Hood is Closed
3. Start the vehicle
4. Buckle the Driver's Seat Belt to prevent the engine auto shut off

		Conditions Met?
Fuel Level:	93.333 %	✓
Hood CLOSED :	Yes	✓
Driver's Seatbelt BUCKLED :	Yes	✓

After all conditions are met, click **Next** to proceed

Back

Next

18. Select Next to start the test.

NOTE: The test cannot proceed if any of the conditions are not met.

19. Let the engine idle for up to 10 hours in a safe and monitored location.

Petrol

VIN: 1HGCVXXXXXXXXXXXX
Vehicle: 2023 HONDA ACCORD

LET ENGINE IDLE FOR TEN (10) HOURS

The pretest session information has been saved. Please select "Resume / Finish / Confirm Pretest" with the HAC VCI connected to both a Wi-Fi network and the vehicle to reopen the session from the Main Menu.

You may now disconnect the HAC VCI and then return for confirmation after the required time has elapsed.

You may reposition the vehicle on dealer property, but excessive driving will void the pretest and all progress will be lost.

Session start time: 2024-11-11 16:51

Approximate finish time: 2024-11-12 02:51

The vehicle needs to run a minimum of 10 hours. If absolutely necessary, you may turn off the engine and resume the Engine Idle Phase from where you left off. To do so, select Resume Pretest from the Main Menu.

20. The HAC can be removed at this time for use on other vehicles.

NOTE: If the engine idle phase must be interrupted by turning off the engine, the test can be resumed by following the instructions below.

Resuming a Test or Confirming a Status

- Used when reconnecting to check test status.
- Used when resuming a test if the vehicle was turned off and the test was paused.

21. Connect the HAC to the DLC.

22. With the vehicle running, repeat steps 8 through 13 to reconnect to the vehicle.

NOTE: If the HAC is already in Campaign mode, skip step 12.

23. Resume or Confirm the test by selecting the Resume / Finish / Confirm Pretest button.

HP Fuel Pump Leak Pretest

This pretest procedure is completed in 3 steps :

1. Precondition the vehicle and let the engine idle for up to 13 hours
2. Return to confirm completion of engine idle phase
3. Prepare engine for Fuel Pump Leak Test

Before proceeding, your Honda Antares Capsule must be:

- Connected to the vehicle's DLC port
- Connected to your dealer's Wi-Fi network or mobile hotspot
- Configured for "Campaign Mode" on HDC

Select an option to continue :

24. Find the VIN for the vehicle on the list, which should be in an **Unconfirmed status**, then click the VIN to open the test session.

NOTE: VINs in **Unconfirmed status** will be in blue text.

Select vehicle VIN below to confirm its status, or click Close to end.							
Date :	Start Time :	VIN :	Year :	Make :	Model :	Status :	Warranty Code :
2024-11-12	08:53	19XFXXXXXXXXXXXX	2025	Honda	CIVIC HYBRID	Unconfirmed	
2024-11-12	08:28	19XFXXXXXXXXXXXX	2025	Honda	CIVIC HYBRID	Cancelled	
2024-11-12	08:00	1HGCYXXXXXXXXXX	2025	Honda	ACCORD HYBRID	Unconfirmed	
2024-11-12	07:56	1HGCYXXXXXXXXXX	2025	Honda	ACCORD HYBRID	Cancelled	
2024-11-12	07:36	1HGCYXXXXXXXXXX	2025	Honda	ACCORD HYBRID	Cancelled	
2024-11-12	07:18	19XFXXXXXXXXXXXX	2025	Honda	CIVIC HYBRID	Cancelled	
2024-11-12	07:16	19XFXXXXXXXXXXXX	2025	Honda	CIVIC HYBRID	Cancelled	
2024-11-12	06:55	1HGCYXXXXXXXXXX	2025	Honda	ACCORD HYBRID	Cancelled	
2024-11-11	16:51	1HGCYXXXXXXXXXX	2023	HONDA	ACCORD	Unconfirmed	
2024-11-11	15:04	1HGCYXXXXXXXXXX	2025	Honda	ACCORD HYBRID	Cancelled	

25. Confirm the HAC ID and VIN are correct. If the engine idle phase is NOT COMPLETED, select Resume Pretest.

NOTE: Test status and time remaining are displayed in the Pretest Status window.

Pretest Status

Engine Idle Phase is NOT COMPLETED

Honda Antares Capsule ID: HAC-000300
 VIN : 19XFXXXXXXXXXXXX
 Vehicle: 2025 Honda CIVIC HYBRID

Engine idle phase was started: **2024-11-12 at 08:53**

Approximate remaining time in Engine Idle Phase: **9 hours**

IF THE ENGINE IS STILL RUNNING - Check the start time above and allow the engine to complete the engine idle phase. You may disconnect the HAC VCI and return for confirmation after the required time has elapsed.

IF YOU ARE RESUMING a previously incomplete engine idle phase, e.g. from yesterday, click **Resume Pretest** below.

Back
Resume Pretest
Close

If the engine idle phase is COMPLETED, select Next to proceed and skip to step 26.

Pretest Status

Engine Idle Phase is COMPLETED

Honda Antares Capsule ID : HAC-000300
 VIN :
 Vehicle :

Click **Next** to proceed to Fuel Pump Leak Test phase

Back
Next

26. Verify the preconditions are met. After selecting Next, follow the on-screen instructions and return to step 20 after the remaining time has elapsed.

VIN : 1HGCYXXXXXXXXXX
Vehicle : 2023 HONDA ACCORD

Preconditions :

1. Confirm the Hood is Closed
2. Start the vehicle
3. Buckle the Driver's Seat Belt to prevent engine auto shut off

Hood CLOSED : **Conditions Met?** ✓

Driver's Seatbelt BUCKLED : ✓

After all conditions are met, click **Next** to proceed

27. Engine temperature must be above 176°F / 80°C to proceed. Click Next once the temperature is reached.

1. Ensure the Engine Coolant Temperature is above 176°F / 80°C

ECT in °F **Conditions Met?** ✓

NOTE: If ECT is below the target temperature, place the vehicle into PGM-FI Maintenance Mode. HAC power will be lost momentarily, returning you to the Resume Test screen. Reselect VIN and proceed through previous steps to return to this screen.

28. Once the Idle Test has completed, proceed to test the fuel pump for hydrocarbons.

NOTE:

The warranty code only indicates that the idle test has been completed, the hydrocarbon test using the HC tester must still be performed.

Prepare Engine for Fuel Pump Leak Test

Proceed to Fuel Pump Leak Test using HC Tester

Write the warranty code below on the repair order. It is required to complete the warranty claim submission

Warranty Code: E4B990

You may disconnect the HAC VCI at any time
Have a nice day

29. In humid areas water may accumulate in the exhaust. Start the engine then rev 2-3 times.

Test the High-Pressure Fuel Pump for Hydrocarbons

Click here to watch the video



1. Remove the intake manifold bracket.

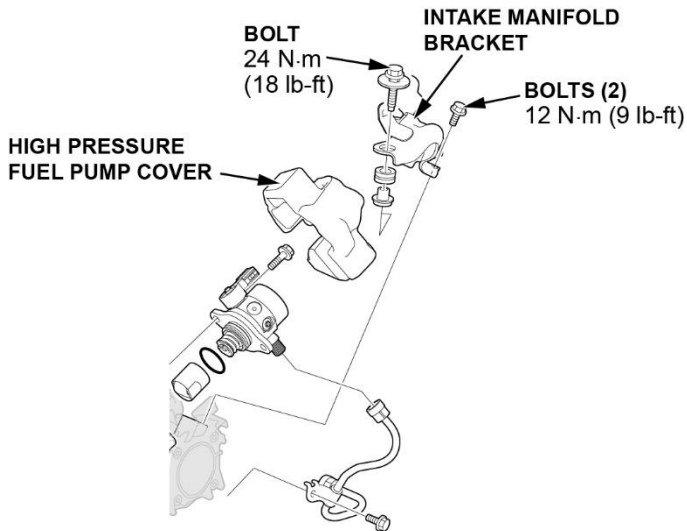

2. Remove the high-pressure fuel pump cover.

3. Verify the Hydrocarbon (HC) tester is operating properly:
 2. **With the engine OFF**, install the emergency funnel in the filler neck.

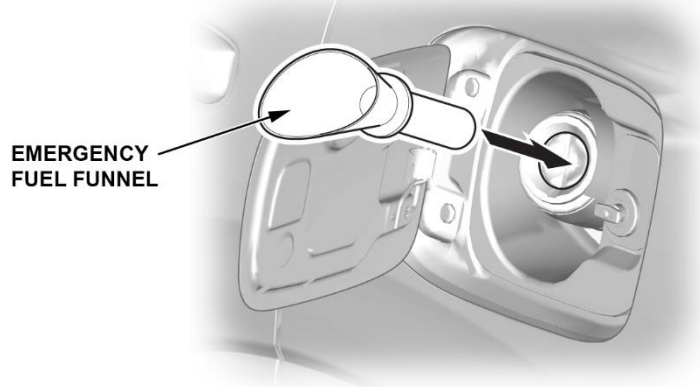

3. Turn on the HC tester by pressing and holding the power button for **3 seconds**. Once powered, the tester will perform a self-check and calibration. Confirm the measurement on the screen is showing 0. Allow the tester to warm up for **30 seconds** before use.

NOTE: If the screen does not show 0 after the self-check, the self-check **was not successful**. Repeat the power-up process. If the tester still does not show 0, switch to a known good tester.



4. **With the engine OFF**, insert the tip of the HC tester probe into the funnel and leave it there for up to **60 seconds**. If the tester produces a reading greater than 0, the tester is working; continue with the inspection process.



5. If there is no reading on the tester, switch to a different tester and repeat the verification process.

4. Connect the i-HDS to the data link connector located under the driver's side dash.

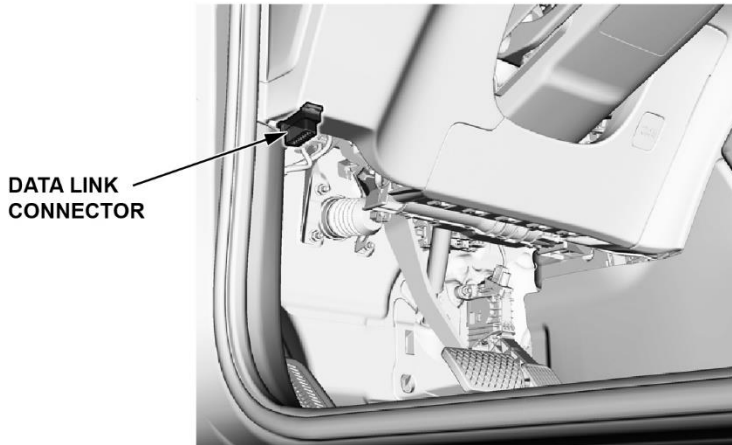

5. Start the engine and make sure the A/C is turned off to prevent the radiator fan from running.
6. Visually check the solenoid area of the high-pressure fuel pump for fuel leakage.

Is fuel leakage found?

Yes – 1. Turn the vehicle to OFF mode.

2. Go to **step 11** of the [Test the High-Pressure Fuel Pump for Hydrocarbon](#) section and scan the QR code to order a replacement high-pressure fuel pump (No further testing required).

No – Proceed to the next step.

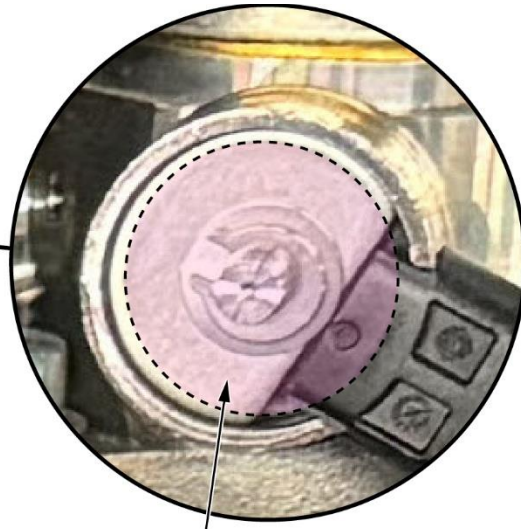
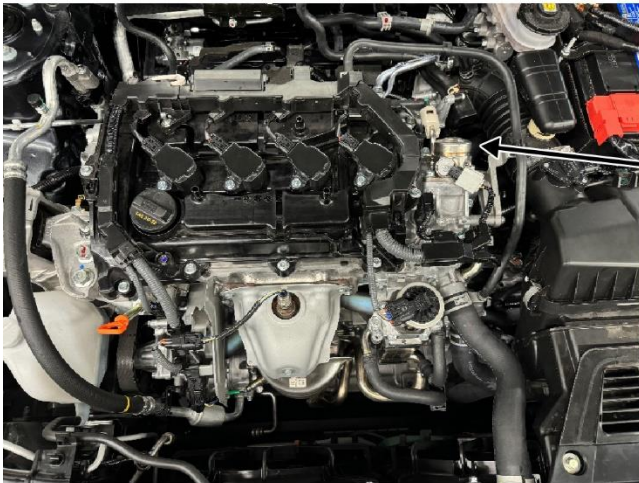

Look for leaks in this area.

7. Select PGM-FI from the i-HDS System Selection Menu. Use the i-HDS to monitor the engine rpm and the engine coolant temperature (ECT Sensor 1).
8. Run the engine at **4,000 rpm** for **at least 80 seconds**, and until the engine coolant temperature (ECT Sensor 1) reaches **176°F**, then let the engine return to idle.

NOTE: The engine will go into fuel cut above **4,000 rpm**, try to keep RPM as close to **4,000** as possible.

▶ Vehicle Selection ▶ System Selection Menu ▶ PGM-FI ▶ Data List ▶

PGM-FI		
Signal	Value	Unit
Engine Speed	4213	RPM
Vehicle Speed	0	MPH
ECT Sensor 1 Voltage	0.69	V
ECT Sensor 1	185	°F

9. Hold the HC Tester probe to the test cap to verify that the test cap has no residual hydrocarbons. If there is a reading above 0 during the test, clean the test cap with soap and water and dry with a clean cloth.

NOTE: **Do not** use anything other than soap and water to clean the test cap.

10. Slide the test cap over the end of the HC tester probe and secure it with the locking nut.

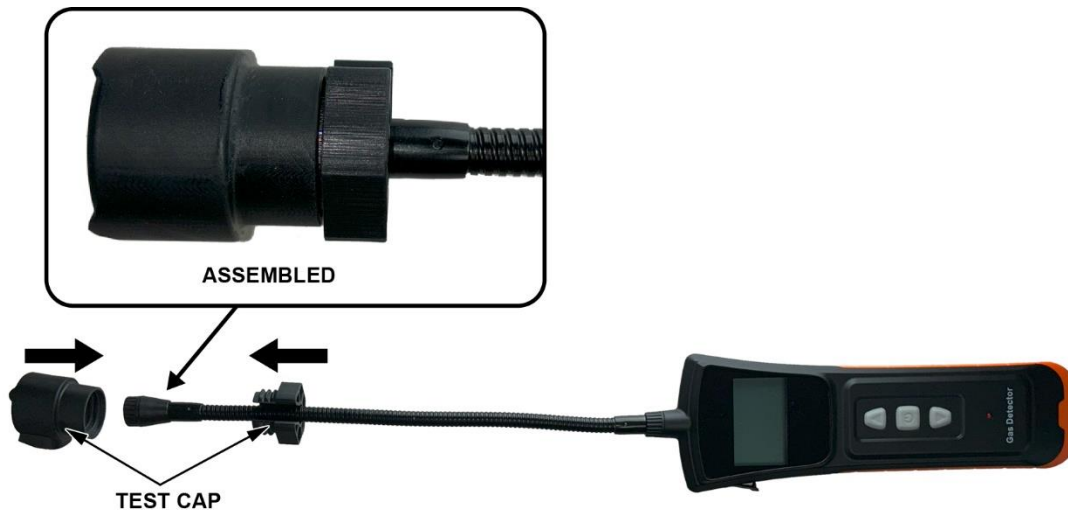

11. With the engine idling, attach the test cap to the high-pressure fuel pump solenoid. Make sure that the cutout in the test cap is aligned with the solenoid connector, then push to fully seat the cap. Leave the tester in place for **60 seconds** then check the reading on the display.

Install test cap here.



TEST CAP



HC Tester Reading	Action
0	Vehicle passed inspection; no repair is necessary. Close the recall.
1–10,000	Do the Retest Procedure below.
<p>Retest Procedure</p> <ol style="list-style-type: none"> 1. Turn the HC tester off and remove the test cap. 2. Turn on the Hydrocarbon (HC) tester by pressing and holding the power button for 3 seconds. Once powered, the tester will perform a self-check and calibration. Confirm the measurement on the screen is showing 0. Allow the tester to warm up for 30 seconds before use. 3. Clean the test cap with mild soap and water and dry with a clean cloth. 4. Retest the test cap for hydrocarbons. If the HC tester reading is above 0, use a different cap. 5. Reattach the test cap to the HC tester. 6. Attach the test cap to the high-pressure fuel pump solenoid. Make sure that the cutout in the test cap is aligned with the connector, then push to fully seat the cap. Leave the tester in place for 60 seconds then check the reading on the display. 	
HC Tester Retest Reading	Action
0	Vehicle passed inspection; no repair is necessary. Close the recall.
1–10,000	<ol style="list-style-type: none"> 1. Take a clear photo of the HC tester reading. 2. Turn the vehicle to the OFF mode. 3. Scan the QR code below to order the replacement high-pressure fuel pump. NOTE: <ul style="list-style-type: none"> • The photos taken during this inspection will be required to order the replacement high-pressure fuel pump. • If you cannot scan the QR code (click here)  <ol style="list-style-type: none"> 4. Once the pump is received, go to REPAIR PROCEDURE. NOTE: DO NOT return the vehicle to the customer until the repair procedure is completed.

REPAIR PROCEDURE

⚠ WARNING

Fuel pump removal exposes fuel, which can ignite, causing a fire or explosion. This can cause serious injury or death. Always work in a well-ventilated area and keep sparks or open flames away.

- Refer to the [Fuel and Emissions Systems Service Precautions](#) before doing the procedure.
- Refer to the [Fuel Line/Quick-Connect Fitting Precautions](#) before doing the procedure.

1. Do the [Fuel Pressure Relieving](#) procedure.
2. Disconnect the 12-volt battery.
 - [12 Volt Battery Terminal Disconnection and Reconnection](#)
3. Remove the air cleaner housing cover:
 1. Disconnect the MAF sensor connector.
 2. Loosen the air flow tube.
 3. Remove the air cleaner housing cover.

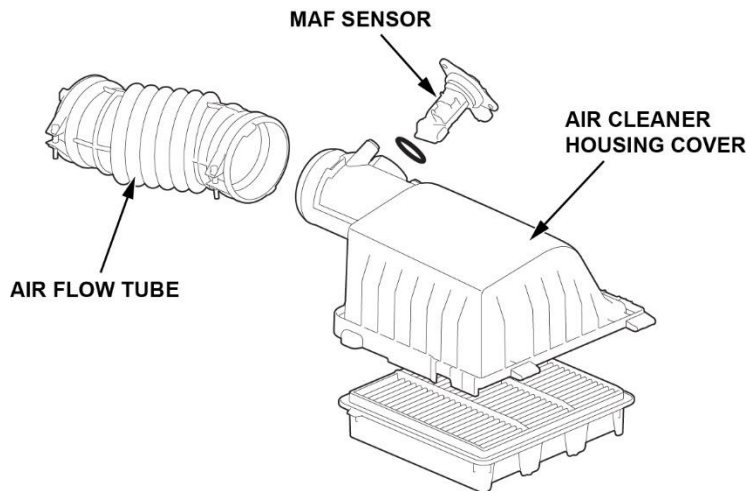

4. Remove the intercooler outlet pipe:
 1. Disconnect the turbocharger boost pressure sensor connector.
 2. Disconnect the intake air sensor 2 connector.
 3. Remove the throttle body inlet hose.
 4. Remove the bolts securing the intercooler outlet pipe B, then remove the intercooler outlet pipe B.

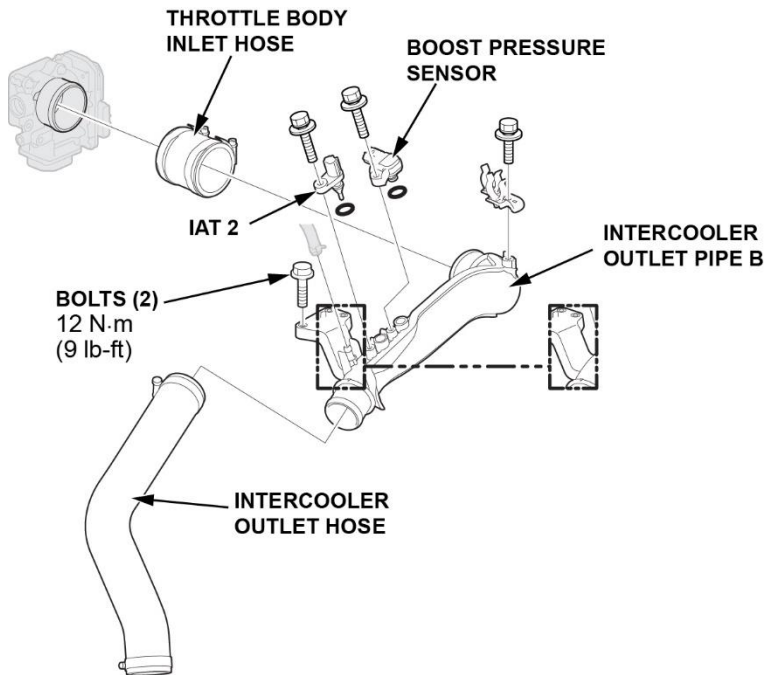

5. Remove the intake manifold:
 1. Disconnect the purge non return A line from the purge control solenoid.
 2. Disconnect the PCV line from the valve cover.
 3. Disconnect the PAP sensor connector.
 4. Remove the turbo bypass control solenoid to intake manifold bracket. (Leave the connector and two air bypass lines connected.)
 5. Disconnect the bypass control solenoid vacuum line to the intake manifold.
 6. Disconnect the two harness stay clips from the intake manifold bracket.
 7. Disconnect the harness on the side of the cylinder head. Release the harness stay clip lift harness and push back to disengage from the intake manifold bracket.
 8. Remove the intake manifold bracket. (This may still be removed from the inspection process.)

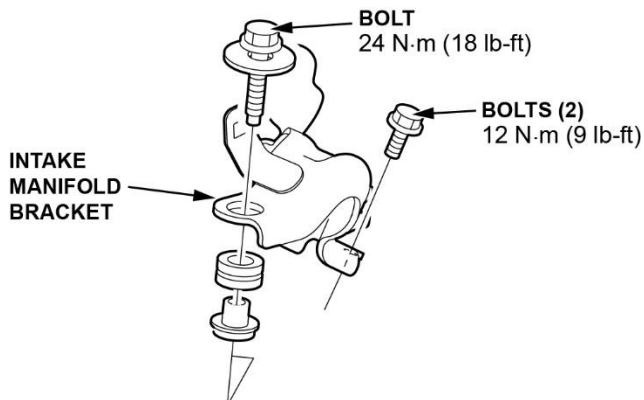

9. Disconnect the vehicle speed sensor (this is to prevent the throttle body from damaging the coupler.)
10. Without removing the coolant hoses, remove the throttle body bolts and move the throttle body to the side.
11. Remove the quick connect fitting covers.
12. Disconnect the fuel feed line quick connect.

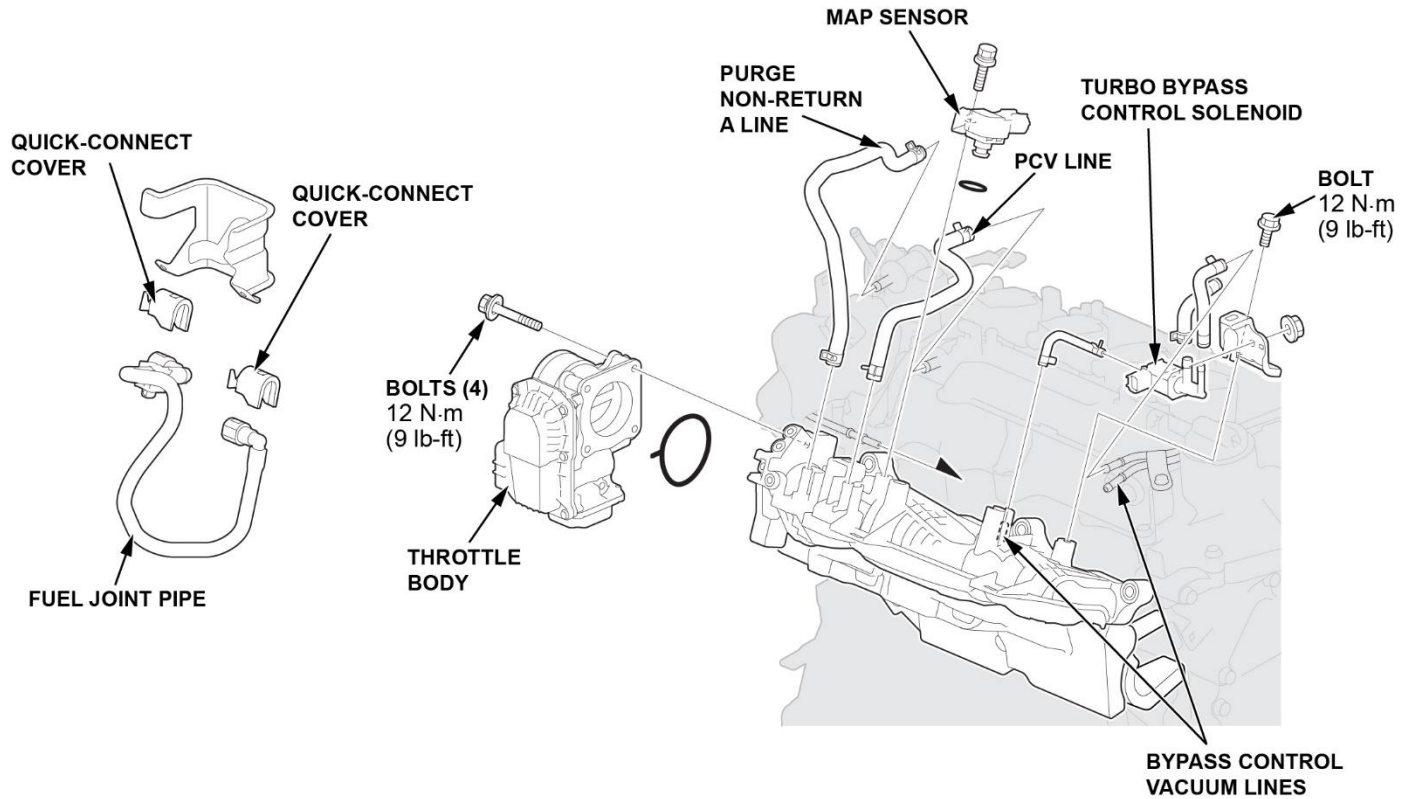

13. Remove the intake manifold cover.
14. Remove the 3 bolts and 2 nuts securing the intake manifold.

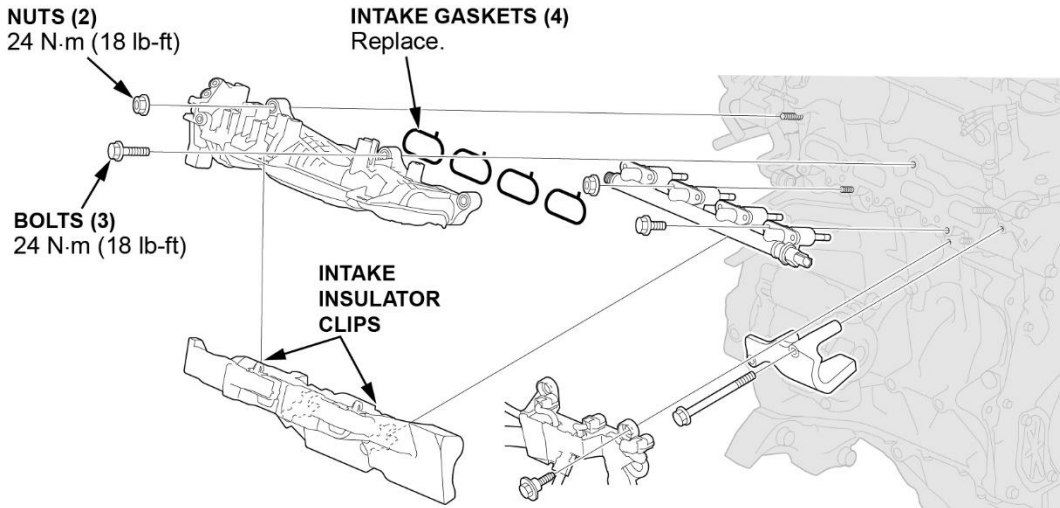

6. Remove the fuel joint pipe.

NOTE: Do not reuse the high-pressure fuel joint pipe.

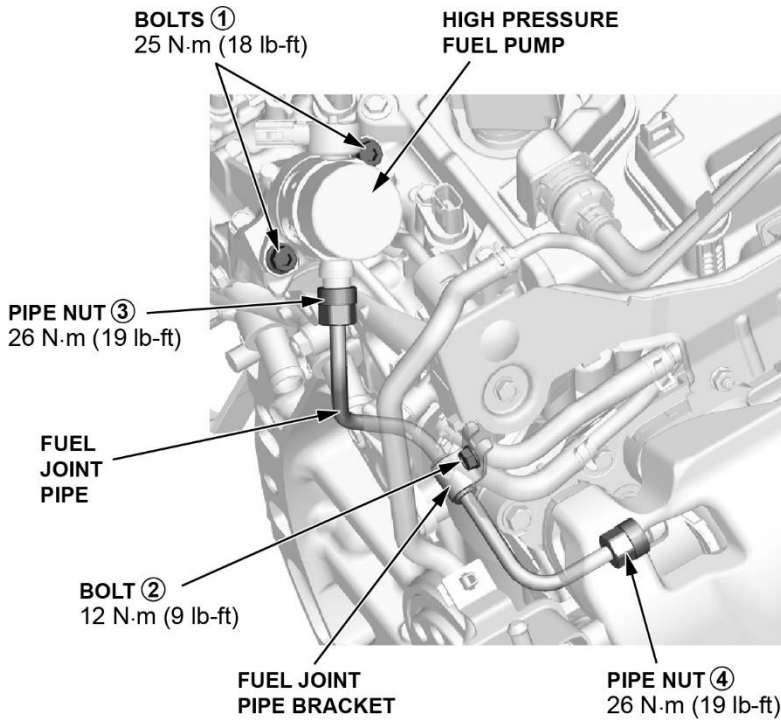

7. Remove the high-pressure pump.

NOTE: Loosen the bolts alternately.

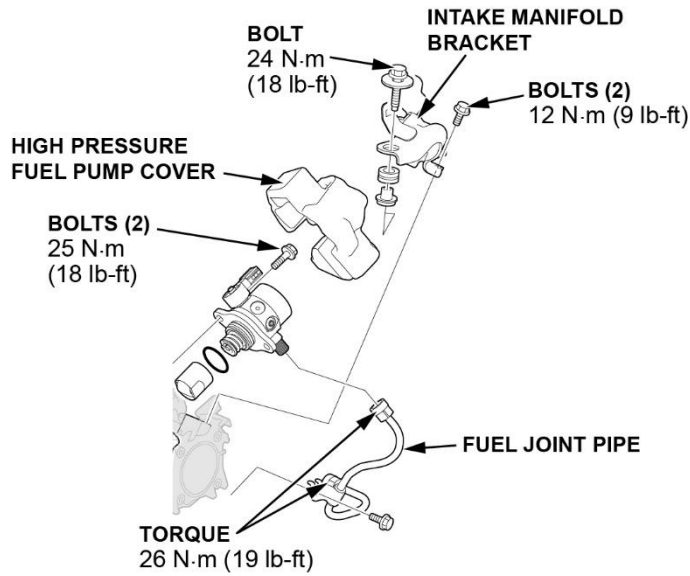

8. Install the new high pressure fuel pump.

1. Check the position of the high-pressure fuel pump cam. If needed, rotate the crankshaft to set it to the flat position.

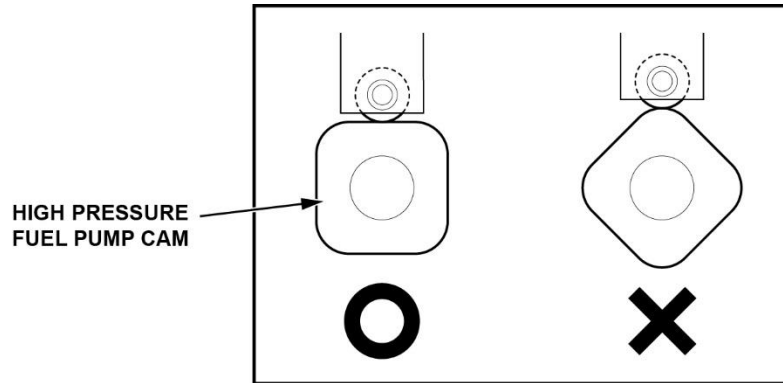

2. Lubricate the O-ring on the new high pressure fuel pump with engine oil.
3. Tighten the high-pressure fuel pump bolts in an alternating pattern until the fuel pump is in contact with the fuel pump base.

NOTE:

- **Do not** final torque at this time.
- To prevent damage to the O-ring, **do not** use any power tools (pneumatic or electric).

9. Install the fuel joint pipe and hand tighten the nuts and stay bolt.
10. Torque the high-pressure fuel pump and joint pipe nuts and bolts in sequence to specification.

NOTE: When using some special tools or crowfoot-type wrenches, the torque value changes due to the added leverage. The actual torque applied will be greater than the torque reading shown.

- The torque specification given is the actual torque, not the reading on the torque wrench.
- To compensate for this additional leverage, use the formula below to calculate the torque value reading on the torque wrench.
- Always use the special tool or crowfoot-type wrench in a straight line with the torque wrench, or you will apply improper torque.

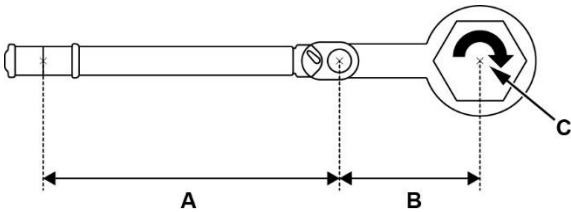

$$\text{Reading of the torque wrench} = \frac{\text{Torque wrench effective length (a)} \times \text{Specified torque (c)}}{\text{Torque wrench effective length (a)} + \text{Special tool/crowfoot type wrench effective length (b)}}$$

Step	Operation	Object	Detail
1	Hand Tighten	③, ④	The end of the joint pipe is seated on the fuel rail or high-pressure fuel pump.
2	Loosely Install	②	Install the fuel joint pipe bracket to the cylinder head, and loosely install it.
3	Tighten	All Bolts and Nuts	① → ② → ③ → ④

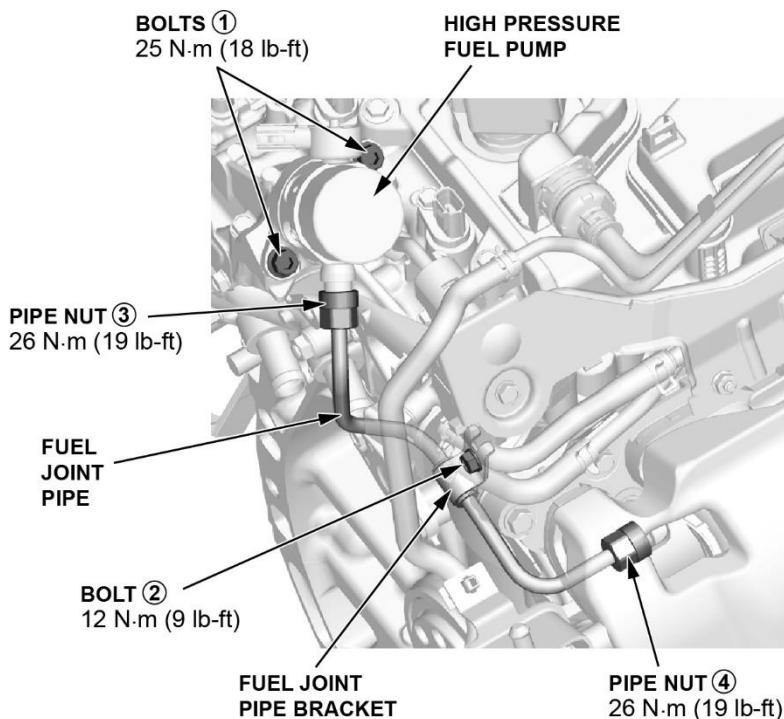

- Apply commercially available Met-L-Check D-70 Developer to the joint of the injectors, the fuel rail, and the high pressure fuel pump.

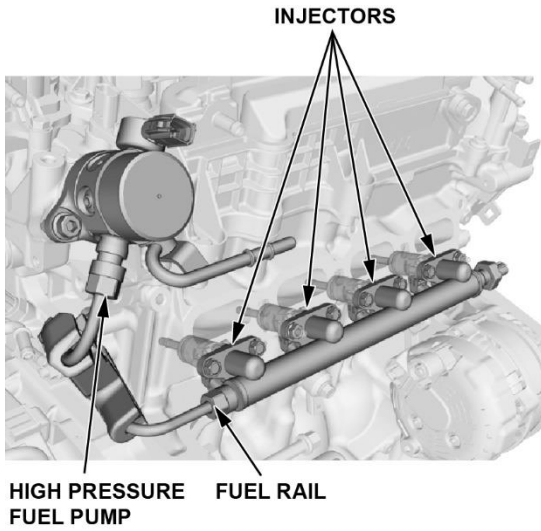

- Install fuel joint pipe quick-connect covers.
- Install the intake manifold with new gaskets. Torque to **24 N·m(18 lb-ft)** in sequence.

Tightening Procedure

Step	Operation	Object	Detail
1	Temporary Tighten	All Bolts and Nuts	Until the bolts and nuts are seated on the intake manifold
2	Temporary Tighten	All Bolts and Nuts	Until the gasket is compressed
3	Tighten	All Bolts and Nuts	①→②→③→④→⑤

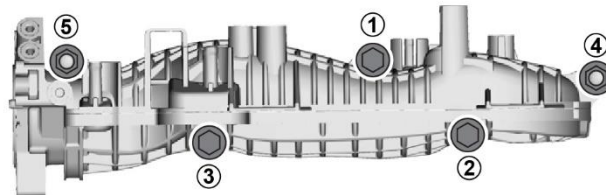

14. Clip the intake insulator to the intake manifold and onto the fuel rail.

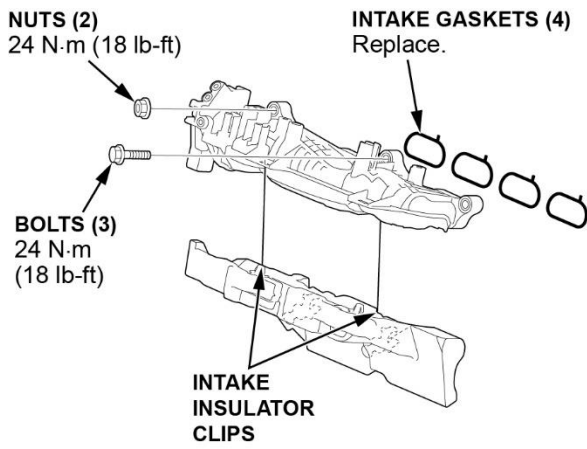

15. Install the throttle body and torque the bolts to **12 N·m(9 lb-ft)** in sequence.

Tightening Procedure

Step	Operation	Object	Detail
1	Temporary Tighten	All Bolts and Nuts	Until the bolts and nuts are seated on the intake manifold
2	Temporary Tighten	All Bolts and Nuts	Until the gasket is compressed
3	Tighten	All Bolts and Nuts	①→②→③→④

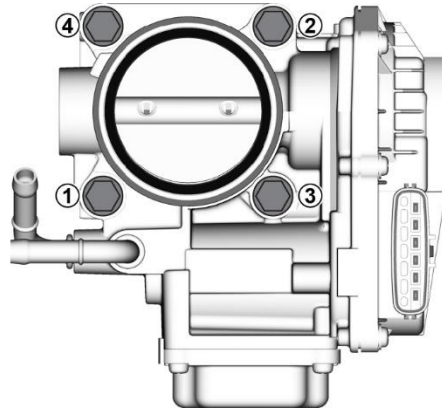

16. Connect the vehicle speed sensor connector.
17. Connect the throttle body connector.
18. Install the turbo bypass control solenoid back onto intake 12N.m(9lb-ft).
19. Connect turbo bypass vacuum line to intake manifold.
20. Connect PCV line to valve cover.
21. Connect purge non return line A.
22. Connect MAP sensor connector.
23. Connect fuel feed line quick-connect fitting.

NOTE: If the quick-connect fitting is stuck on the original high-pressure pump, install a new quick-connect fitting to the line.

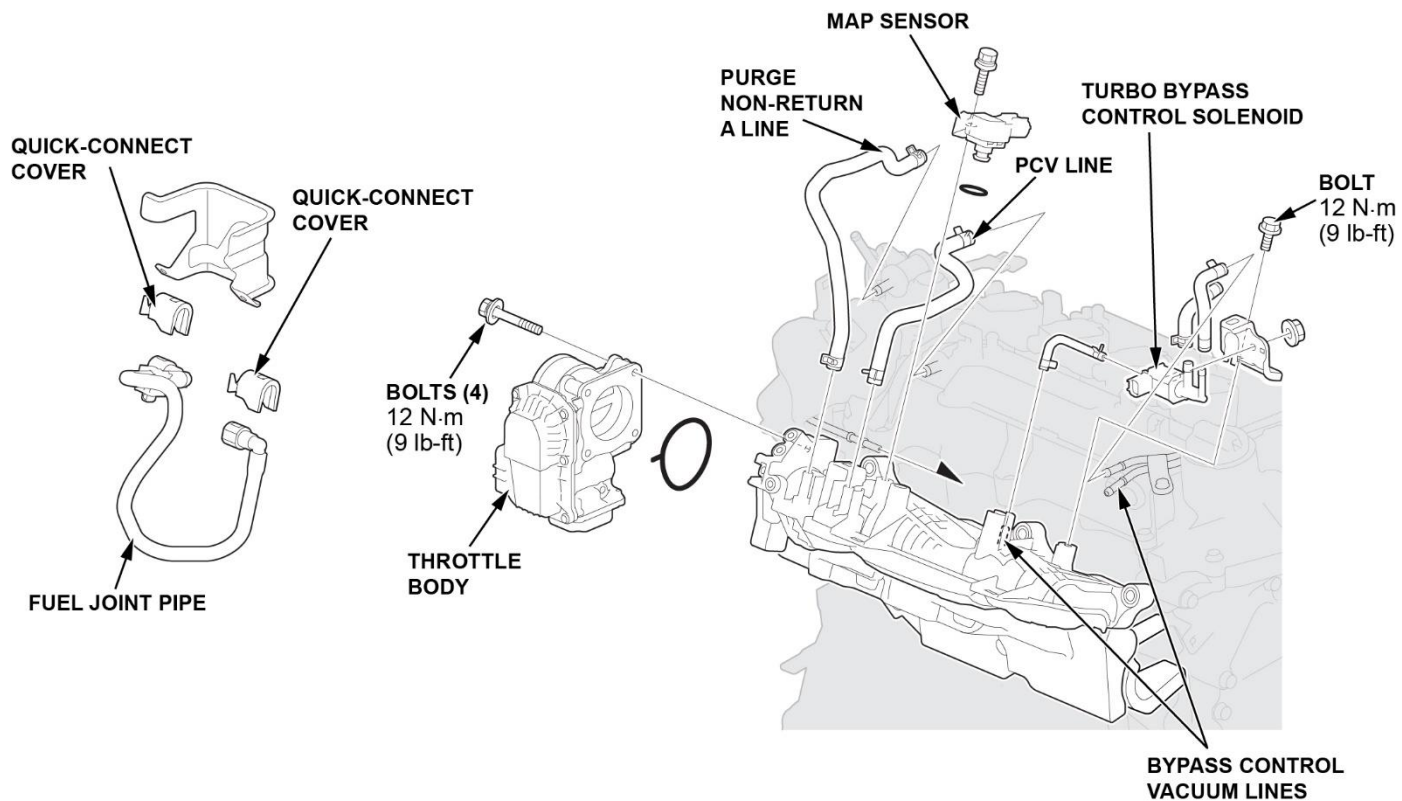

NOTE: Review the [Intake Air System and Exhaust System Service Precautions](#) before doing repairs or service.

24. Install the throttle body inlet hose.
25. Install the intercooler outlet pipe B.
26. Install the intercooler outlet hose and torque bolts to specification.
27. Connect the intake air temperature sensor 2 connector.
28. Connect the boost pressure sensor connector.

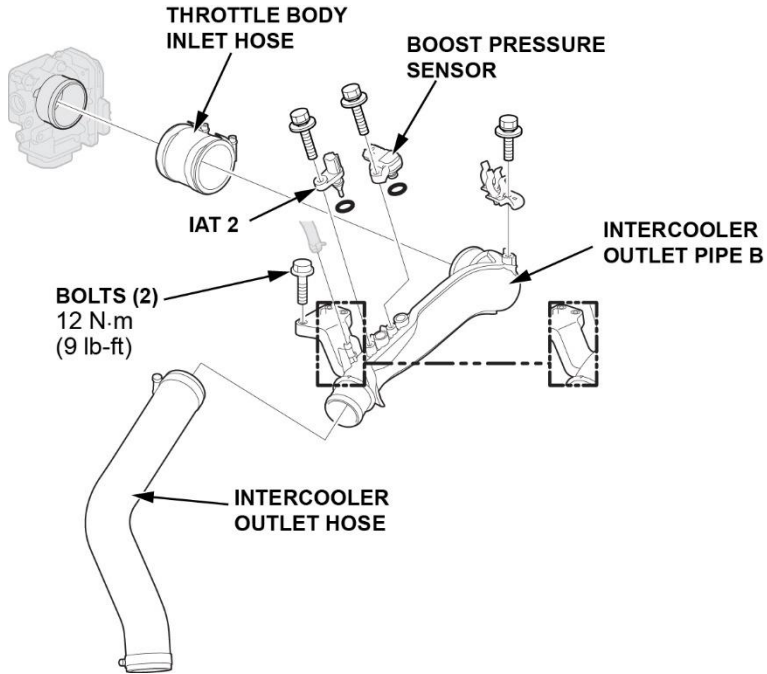

29. Reconnect the 12-volt battery.
 - [12 Volt Battery Terminal Disconnections and Reconnection](#)

30. Check for fuel leaks:

NOTICE

If fuel is leaking, stop the engine immediately and turn the vehicle to the OFF (LOCK) mode.

1. Start the engine and hold the engine speed at **4,000 rpm** for **1 minute**, then stop the engine.
2. Inspect for previously applied Met-L-Check D-70 at the high-pressure fuel pump and fuel rail connections.

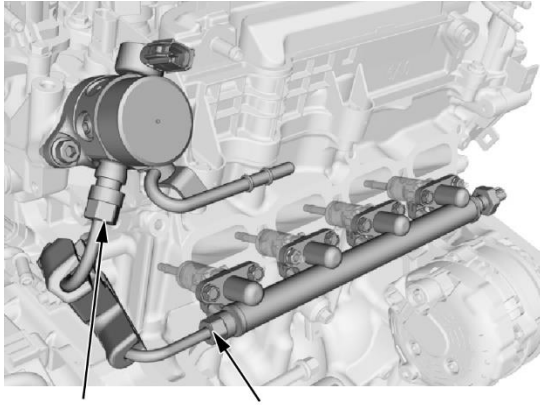

HIGH PRESSURE FUEL PUMP FUEL RAIL

3. Use the HC tester at the high-pressure fuel pump and fuel rail joint pipe connections.
4. Was a leak detected?

Yes - Follow the [Fuel Leak Check \(High Pressure Side\)](#) procedure.

No – Proceed to the next repair step.

31. Install the high-pressure pump cover.

32. Install the intake manifold bracket and torque to specification.

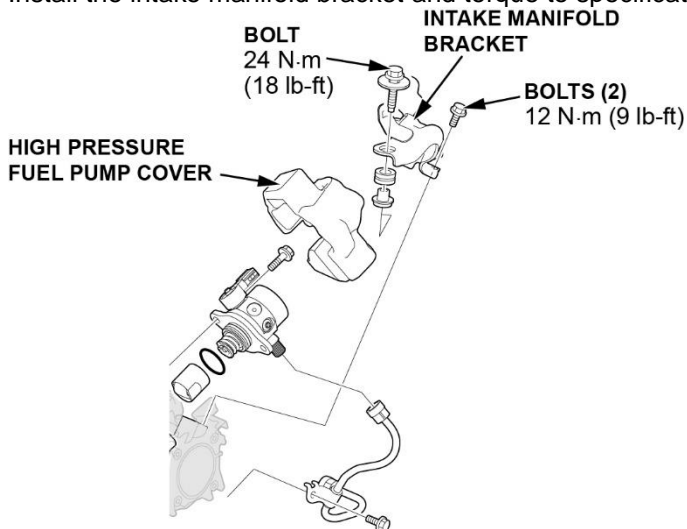

33. Clip the engine harness into the harness stay.

34. Do the [Steering Angle Neutral Position Learning](#).

35. Do an All DTC Clear.

36. *California residents only:* Fill out a Vehicle Emissions Recall – Proof of Correction certificate and use **MK7** as the recall number. Have the service advisor give the certificate to your customer and advise him or her to keep it as proof that the recall was completed. Your customer will need to submit this certificate to the DMV only if the DMV requests it. If you need more certificates, use reorder number **Y0657**.

Vehicle Emission Recall - Proof of Correction				
License Number	Make	Year Model	Body Type	Vehicle Identification Number
				<input type="text"/>
Manufacturer _____			Recall Number MK7	
The above described vehicle has been repaired, modified and/or equipped with emission control devices to meet applicable California Emission Control Laws.				
Dealer's Name _____		Address, City, State and Zip _____		
Date _____	Dealership's Authorized Signature _____			
X				
Return this certificate to DMV only when required - otherwise retain for your records.				

Y0657 ACL 24832 (0212)