

November 19, 2024

Version 2

Safety Recall: 2023 CR-V Hybrid Lithium-ion Battery

Supersedes 24-120 dated October 4, 2024, to revise the information highlighted in yellow.

APPLIES TO

| Year | Model | Trim Level | VIN Range |
|------|-------------|------------|-----------|
| 2023 | CR-V Hybrid | ALL | ALL |

REVISION SUMMARY

Under PARTS INFORMATION, the high-voltage battery order information has been revised.

BACKGROUND

Due to inadequate cladding residual thickness and manufacturing variations of the battery cell negative terminal within the Li-ion battery module, partially exposed aluminum can form an alloy, which can progress and lead to breakage of the terminal or busbar, rendering the vehicle undriveable. If the breakage occurs while the battery is energized, a spark may occur, increasing the risk of a fire, crash, and/or injury.

CUSTOMER NOTIFICATION

Owners of affected vehicles will be sent a notification of this safety recall. Do an iN VIN status inquiry to verify eligibility. Some vehicles affected by this campaign may be in your new or used vehicle inventory.

Failure to repair a vehicle subject to a recall or campaign may subject your dealership to claims or lawsuits from the customer or anyone else harmed as a result of such failure. To see if a vehicle in inventory is affected by this safety recall, do a VIN status inquiry before selling it.

CORRECTIVE ACTION

Replace the Battery Pack assembly.

WARRANTY CLAIM INFORMATION

| Operation Number | Description | Flat Rate Time | Defect Code | Symptom Code | Template ID | Failed Part Number |
|------------------|---|----------------|-------------|--------------|-------------|--------------------|
| 1181HM | Replace battery pack (includes VSA relearn) | 1.5h.r | 6LB00 | HJR00 | A24120A | 1D100-69F-A00 |

Skill Level: Repair Technician

CUSTOMER INFORMATION: The information in this bulletin is intended for use only by skilled technicians who have the proper tools, equipment, and training to correctly and safely maintain your vehicle. These procedures should not be attempted by “do-it-yourselfers,” and you should not assume this bulletin applies to your vehicle, or that your vehicle has the condition described. To determine whether this information applies, contact an authorized Honda automobile dealer.

PARTS INFORMATION

| Part Name | Part Number | Quantity |
|-----------------------|---------------|----------|
| Battery Pack Assembly | 1D100-69F-A00 | 1 |

Ordering a high-voltage battery requires the completion of the High-Voltage Battery Order form.

For this campaign only:

- In the Warranty/Goodwill Information section, enter this service bulletin number **24120** into the Goodwill VSC Authorization field.
- In the Problem Description section, where it asks if a snapshot has been sent, select **YES**.
- **In the customer complaint section, enter Recall 24-120.**

* = Required

High Voltage Battery Order

[Hours of Operation](#)

Dealer Information

Dealer Number: [] Repair Order Number: []
 DPTS ID/Name: << SELECT >> Repair Order Date: [] / [] / []
 SSN: [] (Last four numbers) Approved by Parts Manager: Yes No
 Telephone No.: [] Ext: [] Have you called Tech Line about this problem?: Yes No
Please provide a direct contact number (not the main dealer number).

Vehicle Information

VIN: [] Mileage: 5
 Model: CR-V FHEV Model Year: 2023
 Body Type: SDR Trim Level: AWDSTRG

Warranty/Goodwill Information

Warranty Status: IN WARRANTY Warranty Type: WAR Customer Pay
 First use Date: 05/30/2023 Goodwill VSC Authorization: [] **Enter 24120.**
Disclaimer: Warranty Validation checks manufacturer warranty coverage only. Please obtain authorization prior to submitting Goodwill or VSC/HCPV High Voltage orders.

Complaint Information

Customer's Complaint:
 RECALL 24-120

Problem Description

Can you duplicate the complaint?: Yes No A snapshot is required to process a High Voltage Battery Order. Have you sent in a snapshot?: Yes No **Select Yes.**
 Is this a repeat repair?: Yes No Does Service Manual Troubleshooting indicate replacing the high voltage battery?: Yes No
 Check engine light on?: Yes No

DTCs: [] [] [] []

Comments

List Other Symptoms/Conditions here

| Item | Part Number | Description |
|------|---------------|--------------------|
| 1 | 1D100-69F-A00 | PACK ASSY, BATTERY |

Submit Save Cancel

© 2000 - 2024, American Honda Motor Co., Inc. All Rights Reserved.

REQUIRED MATERIALS

NONE

TOOL INFORMATION

| Tool Name | Part Number | Quantity |
|--------------|-------------|----------|
| Load Leveler | KLS6265744 | 1 |

REPAIR PROCEDURE

NOTE: Make sure to review the [Electric Powertrain Service Precautions](#) and the Job Aid, *High-Voltage Battery Storage and Handling* prior to starting the repair.

1. Open the tailgate before disconnecting the 12-volt battery.
2. Disconnect the negative terminal of the 12-volt battery, [12 Volt Battery Terminal Disconnection and Reconnection](#).
3. Fold the 2nd row seats down and remove the following to access the IPU assembly, [Interior Trim Area](#):
 - Rear Trim Panel
 - Front Cargo Floor Flap
 - Cargo Floor Lid
 - Partition (Both Sides)
4. Remove the service plug on the IPU, [Electric Powertrain Service Precautions for Service Plug](#).
5. Reconnect the 12-volt battery.
6. Connect the i-HDS and check the Motor Inverter Voltage (GEN) voltage. (Step 8 of the Electric Powertrain Service Precautions for Service Plug procedure)

IMPORTANT: Ensure the voltage is below **30 volts or less** before proceeding.

7. Disconnect the negative terminal of the 12-volt battery.
8. Unbolt and disconnect the IPU/Battery Pack assembly, [Electric Powertrain IPU/Battery Pack Area](#)

NOTE: Wrap the battery power cable ends with insulating tape.

9. Using an engine hoist and load leveler, remove the IPU assembly from the vehicle taking care not to scratch or damage the interior and exterior of the vehicle.

NOTE: Make sure to protect the rear lower cargo with a protective mat.



LOAD LEVELER

10. Place the IPU assembly on a clean, flat surface.

11. Remove the IPU Cover from the IPU case, [Electric Powertrain IPU/Battery Pack Area](#).

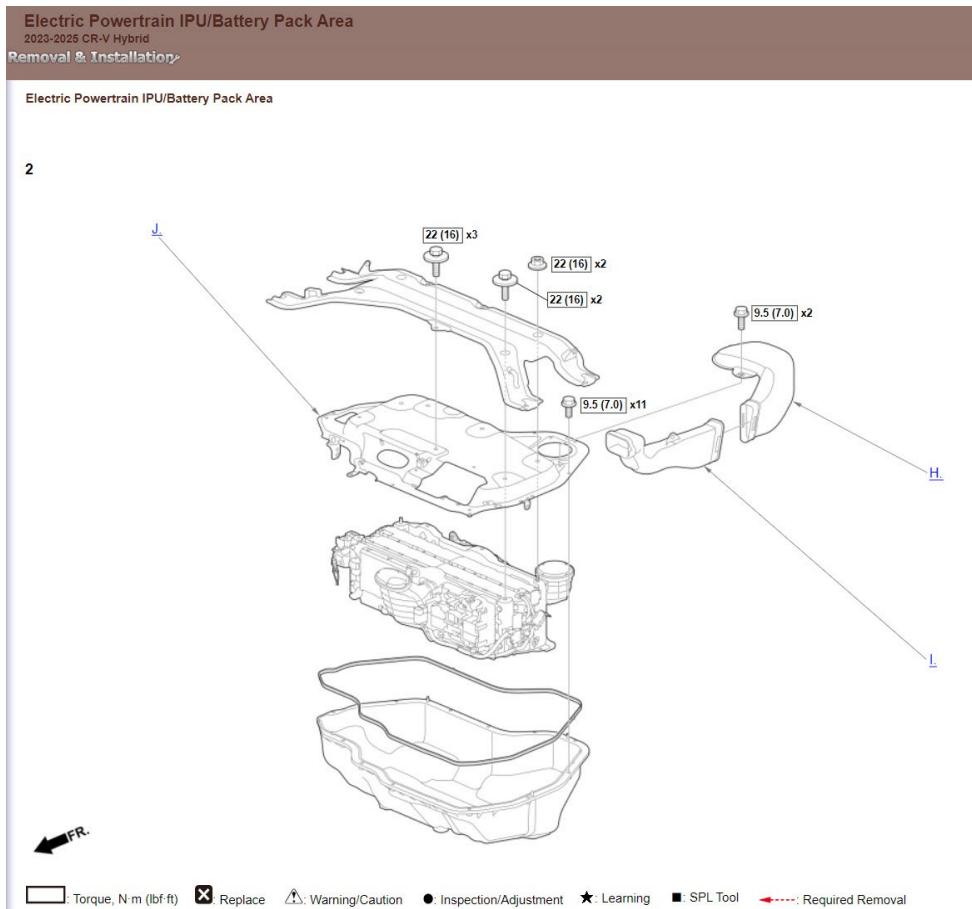

12. Disconnect the remaining high-voltage connectors and wrap them with insulating tape.

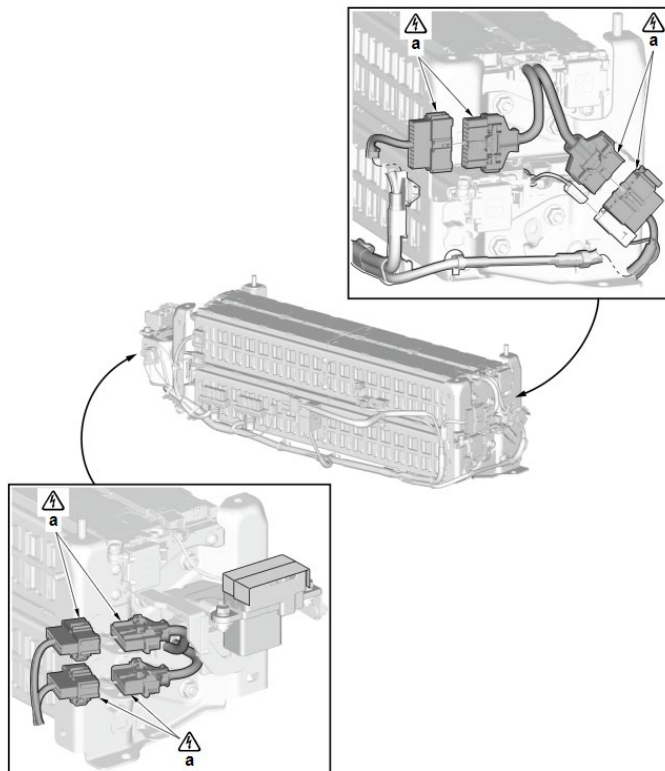

13. Remove the front (O) and rear (Q) battery pack plate, then remove the battery assembly (R).

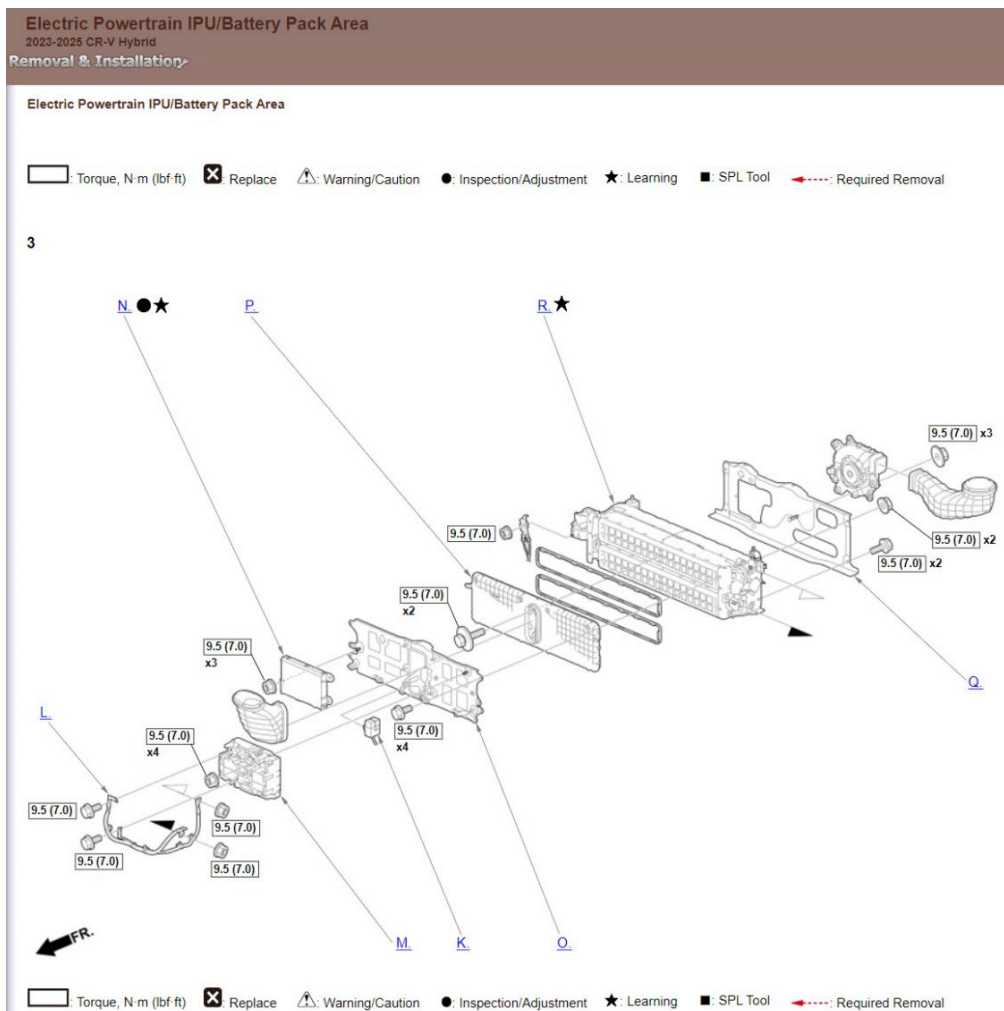

14. Install the new battery pack and reassemble the IPU case in reverse order of removal.

15. Reinstall the IPU assembly into the vehicle.

16. Reconnect the 12-volt battery.

17. Connect i-HDS and perform the *Battery Condition Monitor Module Reset*.

Select the following menu buttons on the HDS screen in sequence.

1. Electric Powertrain (System Selection Menu)

2. HV Battery/HV Battery ECU Replacement

3. HV Battery Replacement

18. Perform [VSA Sensor Neutral Position Memorization](#).

19. *California residents only:* Fill out a Vehicle Emissions Recall – Proof of Correction certificate and use **HJR** as the recall number. Have the service advisor give the certificate to your client and advise him or her to keep it as proof that the recall was completed. Your client will need to submit this certificate to the DMV only if the DMV requests it. If you need more certificates, use reorder number **Y0657**

| Vehicle Emission Recall - Proof of Correction | | | | |
|--|-----------------------------------|------------------------------|--------------------------|-------------------------------|
| License Number | Make | Year Model | Body Type | Vehicle Identification Number |
| | | | | |
| Manufacturer | | | Recall Number HJR | |
| The above described vehicle has been repaired, modified and/or equipped with emission control devices to meet applicable California Emission Control Laws. | | | | |
| Dealer's Name | | Address, City, State and Zip | | |
| | | | | |
| Date | Dealership's Authorized Signature | | | |
| | X | | | |
| Return this certificate to DMV only when required - otherwise retain for your records. | | | | |

Y0657 ACL 24832 (0212)