

Safety Recall

N242477131 Door Striker May Fracture



Release Date: October 2024

Revision: 00

Attention: It is a violation of Federal law for a dealer to deliver a new motor vehicle or any new or used item of motor vehicle equipment (including a tire) covered by this notification under a sale or lease until the defect or noncompliance is remedied.

Vehicles involved in this recall were placed on stop delivery September 18, 2024, under N242477130. Once the service procedure contained in this bulletin has been performed on the vehicle, the vehicle is released from stop delivery and the vehicle can be delivered to the customer.

This is a phased launch.

All involved vehicles that are in dealer inventory must be held and not delivered to customers, dealer traded, or used for demonstration purposes until the repair contained in this bulletin has been performed on the vehicle.

For EV Involved Vehicles: The repairs outlined in this bulletin must only be completed at an authorized EV dealer and repairs must be performed by a technician who has successfully completed the applicable technical training required to perform this repair.

Make	Model	Model Year		RPO	Description
		From	To		
Chevrolet	Blazer	2025	2025		
Chevrolet	Blazer EV				
Chevrolet	Equinox EV				

Involved vehicles are marked "Open" on the Investigate Vehicle History screen in GM Global Warranty Management system. This site should always be checked to confirm vehicle involvement prior to beginning any required inspections and/or repairs.

Condition	General Motors has decided that a defect which relates to motor vehicle safety exists in certain 2025 model year Chevrolet Blazer, Blazer EV, and Equinox EV vehicles. The door strikers in these vehicles were not properly heat-treated to meet GM hardness specifications, making them susceptible to fracture. If a door striker fractures during a crash or while the vehicle is moving, the door may open unexpectedly, increasing the risk of injury.
Correction	Dealers will replace all four side door strikers and attaching bolts.

Parts

Quantity	Part Name	Part No.
8	Bolt	11604173
4	Door Striker	13558435

Reminder: Parts may be removed from SPRINT and Retail Inventory Management (RIM) and be non-returnable. Dealers should review the affected parts to confirm RIM managed status. Parts may have quantity limiters in effect. **Due to the limited initial parts availability, dealers are encouraged not to order these parts for use as shelf stock.**

Warranty Information

Labor Operation	Description	Labor Time	Trans. Type	Net Item
9107653	Replace All Door Strikers	0.6	ZFAT	N/A
9107654	Floor Plan Reimbursement – NEW INVENTORY ONLY	N/A	ZFAT	*

Note: To avoid having to "H" route the floor plan transaction for approval, it must be submitted prior to the repair transaction.

Safety Recall

N242477131 Door Striker May Fracture



Floor Plan Reimbursement – NEW INVENTORY ONLY

* **USA & Canada Dealers Only** – For vehicles eligible for floor plan reimbursement, the amount should be submitted in Net Item/Miscellaneous. This amount should represent the product of the vehicle's average daily interest rate (see table below) multiplied by the actual number of days the vehicle was in dealer inventory and not available for sale. This reimbursement is limited to the number of days from the date of the stop delivery message (September 18, 2024) to the date the repair is completed, and the vehicle is ready for sale (not to exceed 15 days).

Vehicle	Floor Plan Reimbursement Amount	
	USA	Canada
2025 Chevrolet Blazer	\$14.75	\$10.40
2025 Chevrolet Blazer EV	\$19.25	\$13.00
2025 Chevrolet Equinox EV	N/A	N/A

Service Procedure

Note: Failure to mark the location of the old striker will result in poor door striker alignment.

1. Use masking tape to mark the location of the old striker before replacement so that the new striker can be installed in the same position.

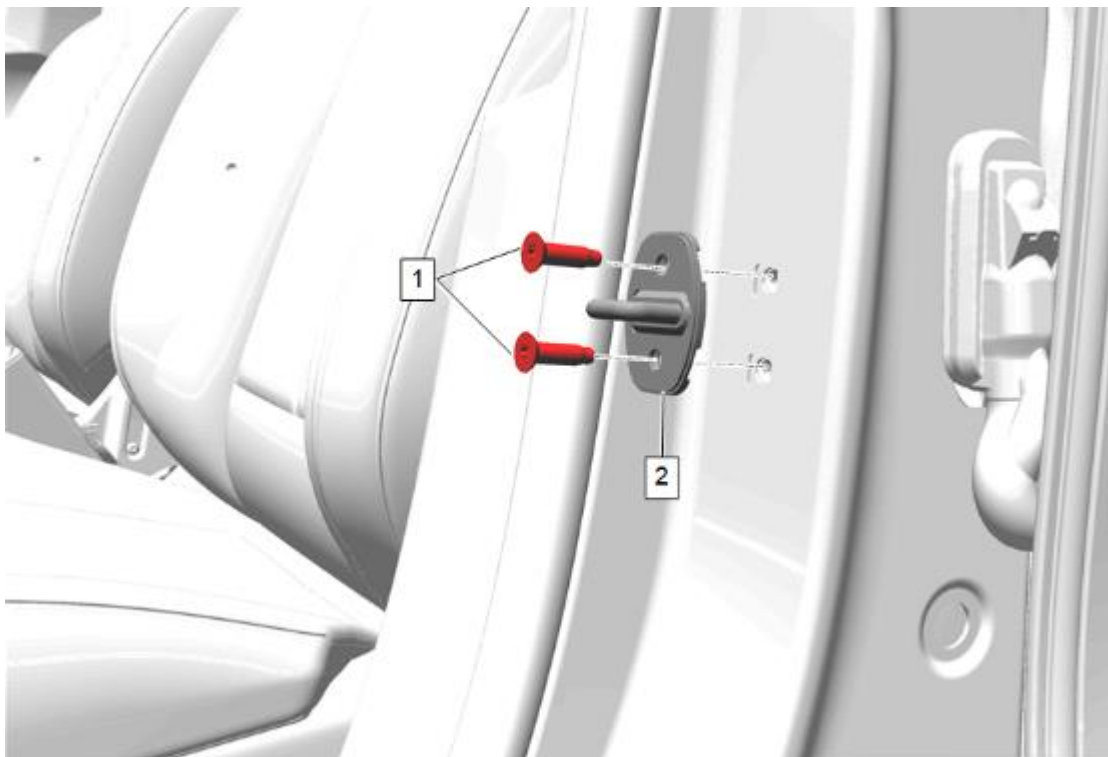

5946511

2. Remove the two bolts (1) holding the Side Door Latch Striker (2) in place. DISCARD the bolts.
 3. Remove and replace the Side Door Latch Striker.
- Note:** All Door Latch Striker bolts MUST be replaced.
4. Install two NEW Door Latch Striker bolts (1). Torque NEW bolts to 22Nm (16 lb ft)
 5. Remove all masking tape.
 6. Repeat steps 1-5 for ALL remaining Door Latch Strikers.

Dealer Responsibility – For USA & Export (USA States, Territories, and Possessions)

It is a violation of Federal law for a dealer to deliver a new motor vehicle or any new or used item of motor vehicle equipment (including a tire) covered by this notification under a sale or lease until the defect or noncompliance is remedied.

Safety Recall

N242477131 Door Striker May Fracture



The US National Traffic and Motor Vehicle Safety Act provides that each vehicle that is subject to a recall of this type must be adequately repaired within a reasonable time after the customer has tendered it for repair. A failure to repair within sixty days after tender of a vehicle is prima facie evidence of failure to repair within a reasonable time. If the condition is not adequately repaired within a reasonable time, the customer may be entitled to an identical or reasonably equivalent vehicle at no charge or to a refund of the purchase price less a reasonable allowance for depreciation. To avoid having to provide these burdensome remedies, every effort must be made to promptly schedule an appointment with each customer and to repair their vehicle as soon as possible. In the recall notification letters, customers are told how to contact the US National Highway Traffic Safety Administration if the recall is not completed within a reasonable time.

Dealer Responsibility – All

All new, used, GM Certified Pre-Owned (CPO), courtesy transportation vehicles, dealer shuttle vehicles, CarBravo, etc. in dealers' possession and subject to this recall must be held and inspected/repaired per the service procedure of this bulletin before customers take possession of these vehicles. Involved vehicles must be held and not delivered to customers, dealer-traded, released to auction, used for demonstration, or any other purpose.

All GM Certified Pre-Owned (CPO) vehicles currently in the dealers' inventory within the SHIFT Digital system will be de-certified and must be held and remedied per the service procedure in this bulletin. Upon submitting an accepted/paid warranty transaction in the Global Warranty Management (GWM) system, the vehicle can be re-certified for sale within the SHIFT Digital system, or once again be used in the Courtesy Transportation Program.

Dealers are to service all vehicles subject to this recall at no charge to customers, regardless of mileage, age of vehicle, or ownership, from this time forward.

Customers who have recently purchased vehicles sold from your vehicle inventory, and for which there is no customer information indicated on the dealer listing, are to be contacted by the dealer. Arrangements are to be made to make the required correction according to the instructions contained in this bulletin. Recall follow-up cards should not be used for this purpose, since the customer may not as yet have received the notification letter.

In summary, whenever a vehicle subject to this recall enters your vehicle inventory you must take the steps necessary to ensure the program correction has been made before selling the vehicle. In addition, for vehicles entering your facility for service, you are required to ensure the customer is aware of the open recall and make every reasonable effort to implement the program correction as set forth in this bulletin prior to releasing the vehicle.

Dealer Reports – For USA & Export

For dealers with involved vehicles, a listing has been prepared and will be available through GM GlobalConnect Maxis Field Action Reports or sent directly to export dealers. The Inventory tab of the dealer reports will contain VINs that apply to this recall. This information is intended to assist dealers with the **PROMPT COMPLETION** of these vehicles. The Customer In-Service tab will contain customer names and addresses from Motor Vehicle Registration Records. The use of such motor vehicle registration data for any purpose other than follow-up necessary to complete this recall may be a violation of law in several states.

Courtesy Transportation – For USA & Canada

Courtesy transportation is available for customers whose vehicles are involved in a product program and still within the warranty coverage period. See General Motors Service Policies and Procedures Manual for courtesy transportation program details.

Customer Notification

USA & Canada - General Motors will notify customers of this recall on their vehicle

Export - Letters will be sent to known owners of record located within areas covered by the US National Traffic and Motor Vehicle Safety Act.

GM bulletins are intended for use by professional technicians, NOT a "do-it-yourselfer". They are written to inform these technicians of conditions that may occur on some vehicles, or to provide information that could assist in the proper service of a vehicle. Properly trained technicians have the tools, equipment, safety instructions, and know-how to do a job properly and safely. If a condition is described, **DO NOT** assume that the bulletin applies to your vehicle, or that your vehicle will have that condition. See your dealer for information on whether your vehicle may benefit from the information.



**We Support
Voluntary Technician
Certification**