



Remedy available for

2020 - 2024 (JL) Jeep Wrangler
 2022 - 2024 (WL) Jeep Grand Cherokee

Template Version 1.0

Revision	Edition	Detail
2	January 2025	Revised Authorized Modifications Label Instructions.

Owners of vehicles previously notified of the B9A recall (NHTSA 23V-787) will need to bring their vehicle in for recall completion, regardless of having the B9A repair performed.

SYMPTOM DESCRIPTION

The High Voltage (HV) battery on about 154,032 of the above vehicles may have been built with a battery pack which contains cells which are susceptible to separator damage. Separator damage, combined with other complex interactions within the cells, may lead to a vehicle fire. A vehicle fire can result in increased risk of occupant injury and/or injury to persons outside the vehicle, as well as property damage.

Vehicle risk is reduced when the battery charge level is depleted. Accordingly, owners are advised to refrain from recharging. Out of an abundance of caution, FCA US is also advising owners of these vehicles to park away from structures or other vehicles until the remedy is obtained.

SCOPE

This recall applies only to the above Plug-In Hybrid Electric Vehicles (PHEVs).

NOTE: Some vehicles above may have been identified as not involved in this recall and therefore have been excluded from this recall.

IMPORTANT:

- Some of the involved vehicles may be in dealer new vehicle inventory. Federal law requires you to complete this recall service on these vehicles before retail delivery. Violation of this requirement by a dealer could result in a civil penalty of up to \$27,168 per vehicle.
- Some of the involved vehicles may be in dealer used vehicle inventory. Dealers should complete this recall service on these vehicles before retail delivery.
- Dealers should also perform this recall on vehicles in for service.

Involved vehicles can be determined by using the VIP inquiry process.

REPAIR TO BE PERFORMED

Perform the Battery Pack Control Module (BPCM) Software Update and Drive Cycle.

Do not replace the High Voltage battery unless DTCs indicates a new battery is required.

Also update the Auxiliary Hybrid Control Processor (AHCP), Hybrid Control Processor (HCP), Integrated Dual Charging Module (IDCM), Powertrain Control Module (PCM) and Transmission Control Module (TCM) if updated software exists for any of those modules.

ALTERNATE TRANSPORTATION

Dealers should proactively minimize customer inconvenience while the recall repair is being performed. Reference the Goodwill Alternate Transportation Guidelines warranty bulletin link within Recall Central on DealerCONNECT for options to support the customer while their vehicle is in service.

COMPLETION REPORTING / REIMBURSEMENT

Claims for vehicles that have been serviced must be submitted on the DealerCONNECT Claim Entry Screen located on the Service tab. Claims paid will be used by FCA to record recall service completions and provide dealer payments.

Use the following labor operation numbers and time allowances:

SAFETY RECALL
NORTH AMERICA
High Voltage Battery



Reference: 95B / NHTSA 24V-720

FCA US LLC

Labor Description	Number	Hrs
Reprogram Battery Pack Control Module (BPCM) and Complete Drive Cycle Routine. (JL) ONLY	18-95-B1-82	0.7
Reprogram Battery Pack Control Module (BPCM) and Complete Drive Cycle Routine. (WL) ONLY	18-95-B1-82	0.6

NOTE: Use the related LOPs for updating the AHCP, HCP, IDCM, PCM and TCM if updated software exists for any of those modules.

(JL) Only

Related Operations	Number	Hrs
Replace High Voltage Battery Pack (JL) Only	18-95-B1-50	3.2
Update AHCP/HCP Software	18-95-B1-51	0.6
Update IDCM Software	18-95-B1-52	0.2
Update PCM Software.	18-95-B1-53	0.2
Update TCM Software.	18-95-B1-54	0.2

(WL) Only

Related Operations	Number	Hrs
Replace High Voltage Battery Pack (WL) Only	18-95-B1-50	4.1
Update AHCP/HCP Software	18-95-B1-51	0.4
Update IDCM Software	18-95-B1-52	0.2
Update PCM Software.	18-95-B1-53	0.4
Update TCM Software.	18-95-B1-54	0.1

Labor Description	Number	Allowance
Floor Plan Reimbursement	95-95-95-97	Calculate See Below

Floor Plan Reimbursement represents the vehicle's average daily allowance (see table below) multiplied by the number of days the vehicle was in dealer inventory and not available for sale. This reimbursement is limited to the number of days from the date of the stop sale to the date that the remedy was made available. Note: If the vehicle was received by your dealership (KZX date) AFTER the stop sale date, you will use the KZX date instead of the stop sale date. For this Recall, the stop sale was initiated on 10/03/2024 and the remedy for (JL) vehicles was made available on 12/07/2024, therefore, the number

of days cannot exceed 65 days. The remedy for (WL) vehicles was made available on 12/20/2024, therefore, the number of days cannot exceed 78 days.

Vehicle	Average Daily Allowance
2020 - 2024 (JL) Jeep Wrangler	██████
2022 - 2024 (WL) Jeep Grand Cherokee	██████

Add the cost of the recall parts plus applicable dealer allowance to your claim.

NOTE: See the Warranty Administration Manual, Recall Claim Processing Section, for complete recall claim processing instructions.

For Mobile Service Reimbursement, dealer to include standard dealer entry and mark-up for parts, standard dealer entry and labor rate for service, as well as the special services code for mobile allowance. The special services LOP will only be paid once per VIN and may NOT be used in coordination with any Alternate Transportation claims.

For additional details, reference the Mobile Service Warranty Bulletin - for convenience, a copy has been linked within Recall Central on DealerCONNECT.

PARTS INFORMATION

No parts are required for this campaign unless HV battery requires replacement.

Very few vehicles are expected to require HV battery replacement.

JL

Part No.	Qty.	Part Name
68488244AA	1	HV Battery Service Kit
68163849AB	1	Coolant
06512293AA	3	Bolt, Rear Seat

WL

Part No.	Qty.	Part Name
68540591AA	1	HV Battery Service Kit
68163849AB	1	Coolant

PARTS RETURN

Return instructions for the old battery are included in the container with the new battery. There is a [REDACTED] core charge for this battery.

NOTE: Please read and follow the I-Sheet instructions that are included with the replacement battery for unpacking upon receipt and packing for return of removed battery information.

NOTE: If the battery return instructions are missing, a battery return I sheet can be downloaded from DealerCONNECT on the “Parts Tab” under the heading “Returns”.

SPECIAL TOOLS

Required for all vehicles:

Number	Description
NPN	wiTECH MDP
NPN	Laptop Computer
NPN	wiTECH Software
10441	Cone, Safety
10442	Barriers, Safety
10452	Sign, Danger High Voltage
10443	Cards, Windshield and Dash Placement
NPN	Level 2 High Voltage Battery Charger

Only if battery replacement is necessary.

Number	Description
2035100082	Covers, HV Battery Terminal
2035203080	Eyebolt, 10mm
2035200080	Lift Straps, HV Battery
BX50-CHR	Table, Bishamon Lift
126-1587	Meter, Fluke
NPN	HV Personal Protection Equipment
2077100080	High Voltage Test Adapter

DEALER NOTIFICATION

To view this notification on DealerCONNECT, select “Global Recall System” on the Service tab, then click on the description of this notification.

OWNER NOTIFICATION / SERVICE SCHEDULING

All involved vehicle owners known to FCA are being notified of the service requirement by first class mail. They are requested to schedule appointments for this service with their dealers. A generic copy of the owner letter is attached.

VEHICLE LISTS, GLOBAL RECALL SYSTEM, VIP AND DEALER FOLLOW UP

All involved vehicles have been entered into the DealerCONNECT Global Recall System (GRS) and Vehicle Information Plus (VIP) for dealer inquiry as needed.

GRS provides involved dealers with an updated VIN list of their incomplete vehicles. The owner’s name, address and phone number are listed if known. Completed vehicles are removed from GRS within several days of repair claim submission.

To use this system, click on the “Service” tab and then click on “Global Recall System.” Your dealer’s VIN list for each recall displayed can be sorted by: those vehicles that were unsold at recall launch, those with a phone number, city, zip code, or VIN sequence.

Dealers must perform this repair on all unsold vehicles before retail delivery. Dealers should also use the VIN list to follow up with all owners to schedule appointments for this repair.

Recall VIN lists may contain confidential, restricted owner name and address information that was obtained from the Department of Motor Vehicles of various states. Use of this information is permitted for this recall only and is strictly prohibited from all other use.

ADDITIONAL INFORMATION

If you have any questions or need assistance in completing this action, please contact your Service and Parts District Manager.

Customer Services / Field Operations
 FCA US LLC.

SERVICE PROCEDURE

A. BPCM Software Update

NOTE: The wiTECH scan tool must be used to perform this Safety Recall. The wiTECH software is required to be at the latest release level before performing this procedure.

NOTE: The BPCM, AHCP, HCP, IDCM, PCM, and TCM must all be updated to the latest available software at the conclusion of this repair procedure. Refer to all applicable published technical service bulletins for detailed repair procedures regarding updating the AHCP, HCP, IDCM, PCM, and TCM software.

CAUTION: BPCM must be updated first. Failure to update the AHCP, HCP, IDCM, PCM, and TCM module following an BPCM software update may result in vehicle malfunctions.

NOTE: It is normal for the high voltage charging lamp on the dash to flash like there is a charging system failure while performing software updates.

NOTE: If the BPCM reprogramming is aborted or interrupted during reprogramming, it must be restarted. The BPCM software must be at the latest software calibration level after completing this safety recall.

1. Install a 12-Volt battery charger. Do not allow the charger to time out during the flash process. Set the battery charger timer (if so equipped) to maintain 12-Volt continuous charge.

NOTE: The vehicle **MUST NOT** be connected to a high voltage battery charger during the flash process.

2. Connect the wiTECH MDP to the vehicle data link connector.

NOTE: Same wiTECH MDP **MUST** be used throughout the procedure.

3. Place the ignition in the “**RUN**” position.
4. Open the wiTECH 2.0 website.
5. Enter your “**User ID**” and “**Password**” and your “**Dealer Code**”, then select “**Sign In**” at the bottom of the screen. Click “**Accept**”.
6. From the “**Vehicle Selection**” screen, select the vehicle to be updated.
7. From the “**Action Items**” screen, select the “**Topology**” tab.
8. From the “**Topology**” tab, select the “**BPCM**” module icon.
9. From the “**Topology**” tab, select “**ALL DTCs**” then “**Clear All**”. If any fault code(s) are present, repair as directed in the service manual procedure. If there are no active fault code(s) proceed to next step.
10. Disable HV Battery Contactors using wiTECH - Go to the Misc Functions tab / Select Disable HV Battery Contactors / then follow the wiTECH prompts. Wait 5 minutes then use wiTECH to confirm that the contactors are open. If the contactors do not open turn the ignition on then off. Once successful a note will appear on the wiTECH screen indicating the contactors are open.

11. From the “**Action Items**” screen, select the “**All Flashes**” tab.
12. Select “**BPCM**” by clicking the arrow on the right side of the screen. Read the special flash instructions, then select “**OK**”. Continue with **Step 13**.
 - If “**BPCM**” is not displayed as one of the available flashes, the **BPCM** software is already at the current software level and does not require updating. Proceed to **Step 17**
13. From the “**Flash ECU Agreement**” page, agree to terms by “**Checking the Box**”.
14. Select “**Flash ECU**” and then follow the wiTECH screen instructions to complete the flash.
15. Once the software is confirmed to be at the latest available calibration level, select “**View DTCs**”.
16. Select the “**Clear All DTCs**” tab, then click “**Clear All DTCs**” and then select “**Close**”. It may be necessary to cycle the ignition to OFF then back to RUN to clear the codes.
17. The AHCP, HCP, IDCM, PCM, and TCM must be updated to the latest available software. Refer to all applicable published technical service bulletins for detailed repair procedures regarding updating the IDCM, PCM, and TCM software. Claim the Related LOPs for AHCP, HCP, IDCM, PCM, and TCM updates if software requires updating.
18. Enable HV Battery Contactors using wiTECH - Go to the Misc Functions tab / Select Enable HV Battery Contactors For Service / then follow the wiTECH prompts.
19. Place the ignition in the “**OFF**” position.
20. Remove the 12-volt battery charger from the vehicle.
21. Proceed to **Section B. Drive Cycle**.

B. Drive Cycle

NOTE: The wiTECH scan tool must be used to perform this routine. The wiTECH software is required to be at the latest release level before performing this procedure.

Preparation for Drive Cycle:

1. Charge high voltage battery to 75% State of Charge.
2. Release the hood latch(es), start the vehicle and idle until coolant temperature reaches 160 degrees Fahrenheit (71 degrees Celsius).
 - In cold ambient temperature, use this period to condition the air inside the vehicle.

NOTE: Use of a mobile internet connection is REQUIRED for the Drive Cycle routine.

3. Connect the wiTECH MDP to the vehicle data link connector.

NOTE: Same wiTECH MDP MUST be used throughout the procedure.

4. Place the ignition in the “**RUN**” position.
5. Open the wiTECH 2.0 website.
6. Enter your “**User ID**” and “**Password**” and your “**Dealer Code**”, then select “**Sign In**” at the bottom of the screen. Click “**Accept**”.
7. From the “**Vehicle Selection**” screen, select the appropriate vehicle.
8. From the “**Action Items**” screen, select the “**Topology**” tab.
9. Select “**BPCM**” Icon.
10. Select “**System Test**” tab.

NOTE: The vehicle MUST NOT be connected to a high voltage battery charger during the system test.

NOTE: This Drive Cycle consists of a sequence of accelerating and decelerating (coasting) between the speeds of 25 MPH and 50 MPH.

- If it is necessary to drive the vehicle to an appropriate testing area, it is recommended to select “**ESAVE**” mode to preserve the 75% SOC.
- If the battery SOC is above 75%, drive the vehicle with either “**HYBRID**” or “**EV**” mode to deplete the battery **before** starting/selecting the Drive Cycle routine.

Begin Drive Cycle:

NOTE: During drive cycle routine, it will be helpful to Refer to the Drive Cycle Sequence Reference Sheet on last page of this document while performing the routine. The vehicle drive sequence steps will no longer be displayed on wiTECH screen once the routine begins.

11. Select “**95B/96B Drive Cycle**” then follow the wiTECH screen instructions to complete the routine. At the conclusion of the routine, wiTECH will advise the next step.

- If the wiTECH Routine indicates the High Voltage Battery requires replacement, proceed to:
 - **Section: C. (JL) Jeep Wrangler - High Voltage Battery Pack Replacement Procedure.**
 - **Section: D. (WL) Jeep Grand Cherokee - High Voltage Battery Pack Replacement Procedure.**

NOTE: Obtain a Vehicle Scan Report VSR and ECU details report. Both must be provided to the STAR Center for High Voltage Battery replacement authorization.

- a) Create and save a Vehicle Scan Report VSR and ECU details report before proceeding. Both pre and post scan reports **will be required** for submission.
- b) From the left column in the analysis section, select “**Reports**”.
- c) On the reports page, select “**Vehicle Scan Report**”.
- d) Repeat to obtain ECU details report.
- e) Select “**Printer Friendly**” then save file type as “**PDF**”. Name the file with the last eight digits of the VIN.

C. (JL) Jeep Wrangler - High Voltage Battery Pack Replacement

Only individuals with high voltage training and repair qualifications should be allowed to handle, troubleshoot, or repair High Voltage (HV) or Hybrid components or systems.

1. Power down the electrical system (Refer to the detailed procedures available in DealerCONNECT > Service Library > under: 12 - Electrified Powertrain System / High Voltage Battery / Standard Procedure / High Voltage Power Down).
2. Raise and support the vehicle Raise and support the vehicle. (Refer to the detailed procedures available in DealerCONNECT > Service Library > under: 04 - Vehicle Quick Reference/Hoisting/Standard Procedure).
3. Remove the eight push pin fasteners from the front air dam (1) (Figure 4).
4. Remove the bolts (2) (Figure 4).
5. Remove the air dam (1) (Figure 5).
6. Remove the support and lower the vehicle.

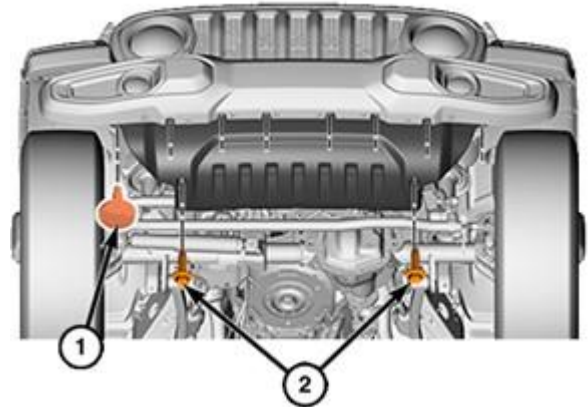

Figure 4 – Air Dam Fasteners

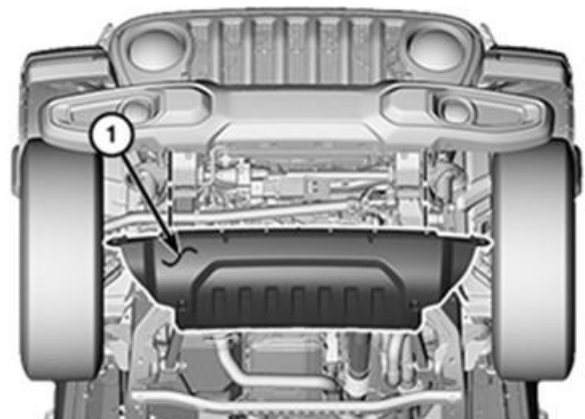

Figure 5 – Air Dam

SAFETY RECALL
NORTH AMERICA
High Voltage Battery



Reference: 95B / NHTSA 24V-720

FCA US LLC

7. Disconnect the vacuum boost hose quick coupling (1) from the air cleaner body cover (Figure 6).

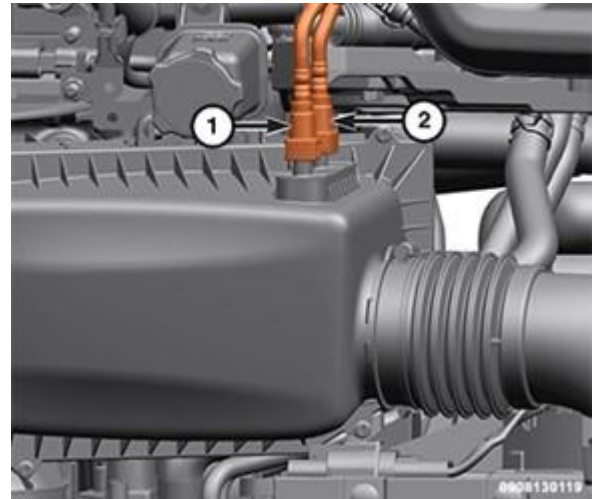

Figure 6 – Air Cleaner Cover

- Push in and hold both sides of the grey release (1) on the quick coupling (Figure 7).
- Pull the quick coupling away from air cleaner body cover.



Figure 7 – Hose Connections

8. Disconnect the fuel vapor purge hose quick coupling (2) from the air cleaner body cover (Figure 6).
- Do not press on the green anti-tampering feature (1) (Figure 8).
 - Push in and hold only the side of the release (2) with the green anti-tampering feature and pull the quick coupling away from air cleaner body cover.



Figure 8 – Hose Connections

9. Loosen the clean air hose band clamp (2) (Figure 9).
10. Remove the bolt (3) (Figure 9).
11. Disengaging the air cleaner body (1) from the two lower rubber grommets and from the clean air hose (Figure 9).

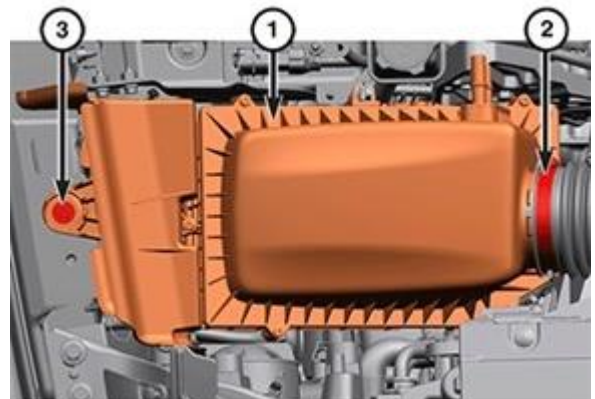

Figure 9 – Air Cleaner

12. Raise and support the vehicle.
13. Position a drain pan under the coolant hoses (Figure 10).
14. Remove the coolant hoses from the coolant line and drain the power electronics cooling system (Figure 10).
15. Once the system is completely drained, reinstall the coolant hose to the coolant line (Figure 10).
16. Remove the fasteners (1) and the skid plate (2) from the vehicle (Figure 11).

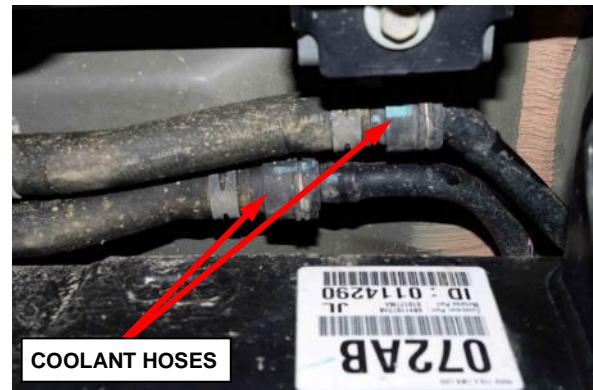

Figure 10 – Coolant Hoses

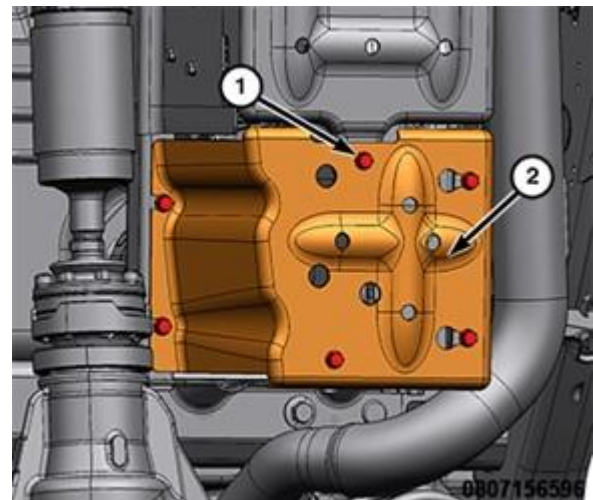

Figure 11 – Skid Plate

SAFETY RECALL
NORTH AMERICA
High Voltage Battery



Reference: 95B / NHTSA 24V-720

FCA US LLC

- 17. Disconnect the HV wire harness connectors (1) and (2) from the HV battery (Figure 12).

- 18. Cap the HV cables using Covers, High Voltage Battery Terminal 2035100082.

NOTE: A Plug-in Hybrid Electric Vehicle (PHEV) HV Battery Cover/Plug Kit is also available from Mopar® Parts.

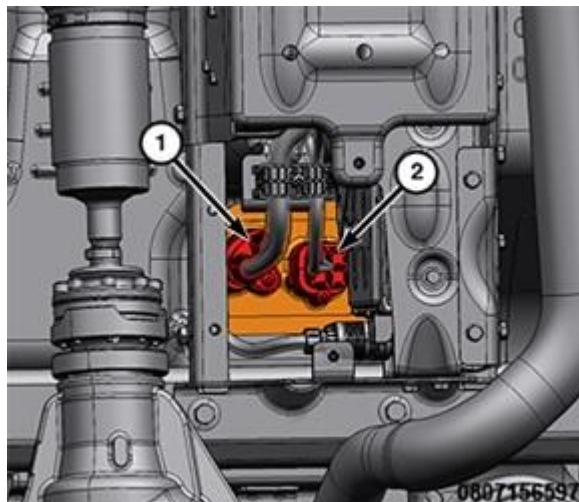

Figure 12 – HV Battery Wiring Connectors

- 19. Remove the support and lower the vehicle.

- 20. Using a trim stick, release and remove the B-pillar trim cover (1) (Figure 13).



Figure 13 – B-pillar Trim Cover

21. Disconnect the wire harness connector (2) and release the door tether from the support bracket (1) (Figure 14).



Figure 14 – Harness to Support Bracket

22. Remove the bolt (2) securing the door check (1) (Figure 15).

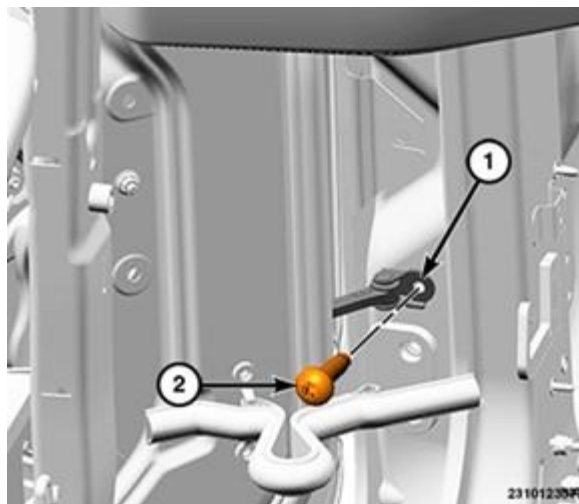

Figure 15 – Door Check Bolt

- 23. Remove the nuts (3) and lift the door up off hinges (1) and remove (Figure 16).

- 24. Raise the rear seat cushion.

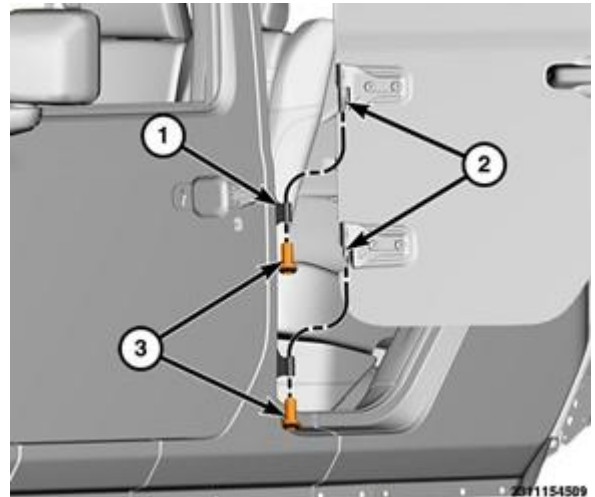

Figure 16 – Hinge Pin Nuts

- 25. Remove the fasteners (1) from the side high voltage battery trim panels (2) (Figure 17).

- 26. Using a trim stick or equivalent, remove the high voltage trim panel upward to release the retainers and remove the trim panel. Repeat for the passenger side.

- 27. Lower the rear seat cushion.

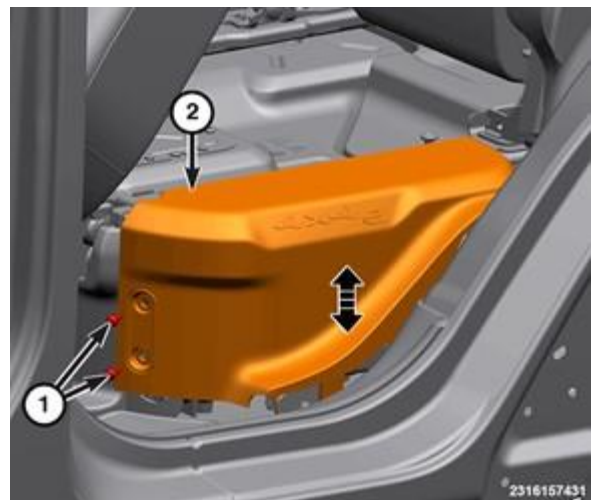

Figure 17 – HV Battery Side Trim

- 28. Using a trim stick or equivalent, release the retainers from the front high voltage battery closeout and remove from vehicle (Figure 18).

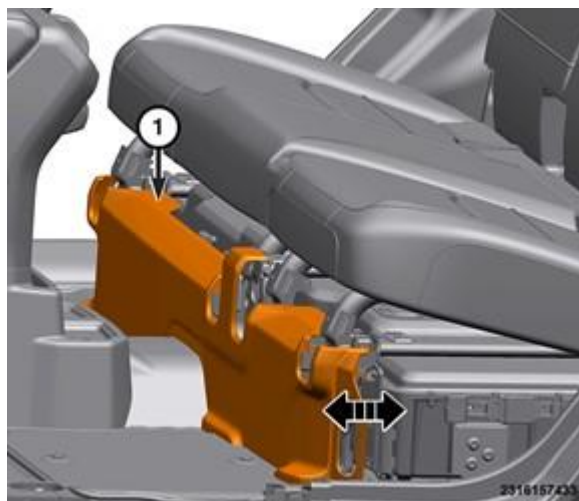

Figure 18 – HV Battery Front Trim

- 29. Remove the rear seat to load floor gap hider (Figure 19).



Figure 19 – Gap Hider

- 30. Disconnect the wire harness connectors, if equipped (4) (Figure 20).
- 31. Remove the nut for the center seat belt anchor (6). Remove the seat belts from the floor stud (Figure 20).
- 32. Remove the rear seat fasteners (2) at the rear of the seat (Figure 20).

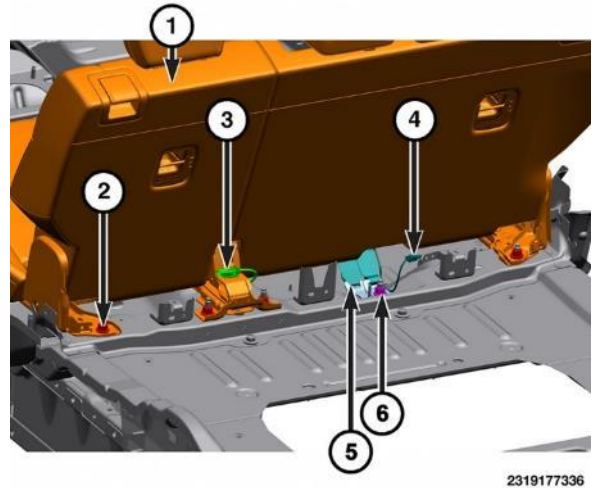

2319177336

Figure 20 – Rear Seat Components

- | | |
|----------------------------|---------------------------------|
| 1 - Rear Seat | 4 - Wire Harness Connector |
| 2 - Rear Seat Nuts | 5 - Seat Belts |
| 3 - Wire Harness Connector | 6 - Center Seat Belt Anchor nut |

- 33. Disconnect the wire harness connectors (2), if equipped (Figure 21).
- 34. Remove the bolts (1) at the front of the rear seat (Figure 21).

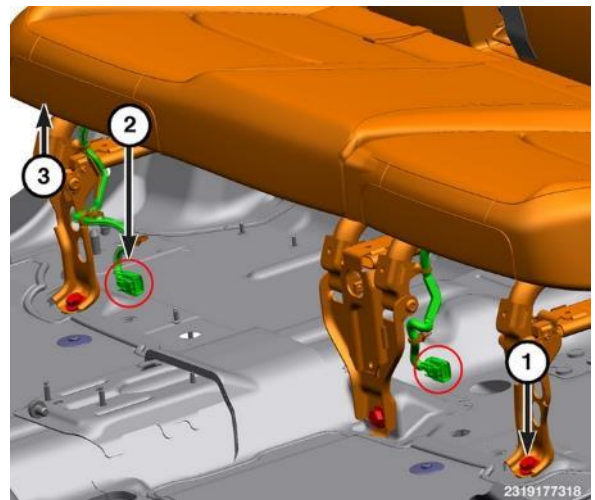

2319177318

Figure 21 – Rear Seat Components

- 1 - Rear Seat Bolts
- 2 - Wire Harness Connectors
- 3 - Rear Seat

- 35. Remove silencer pad (Figure 22).
- 36. Remove the seat from the vehicle.

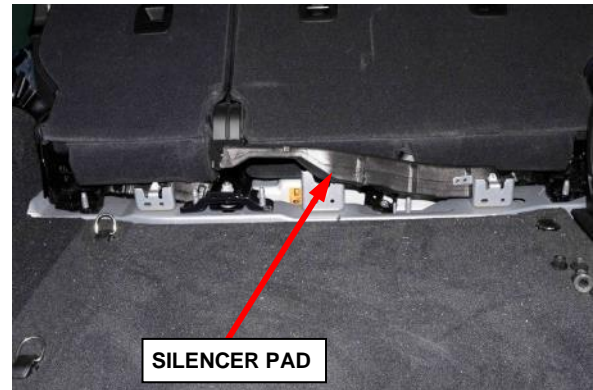

Figure 22 – Silencer Pad

- 37. Remove the fastener (1) and the chassis ground cable from the HV battery (2) (Figure 23).

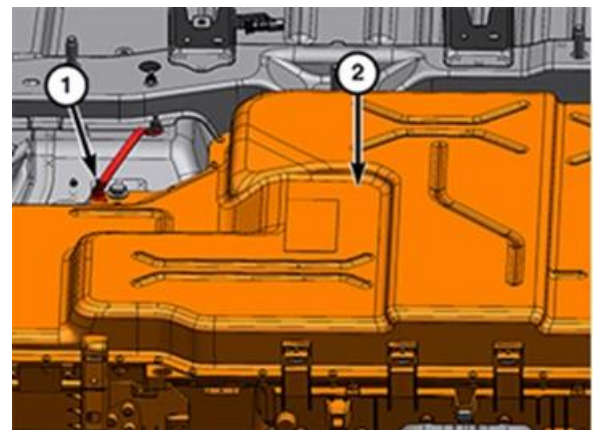

Figure 23 – HV Battery Fastener and Ground Cable

38. Disconnect the HV wire harness connectors (1) (Figure 24).

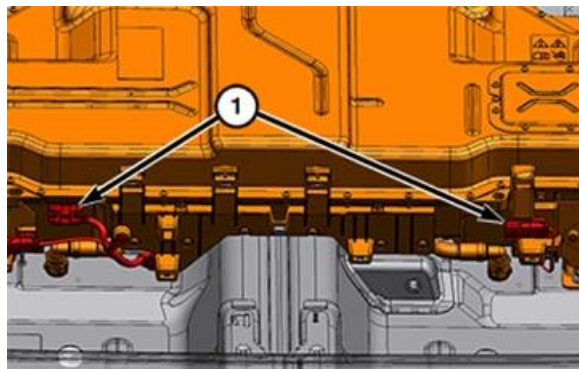

Figure 24 – HV Wire Harness Connectors

NOTE: Use an absorbent pad to collect any coolant that may leak from the battery into the interior of the vehicle.

39. Disconnect and plug the HV battery coolant line connectors (1) (Figure 25).

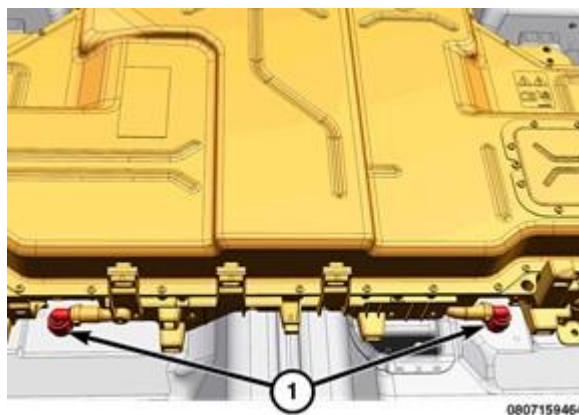

Figure 25 – HV Battery Coolant Connectors

NOTE: The HV battery pack weighs 167 kg (368 lb.).

- 40. Remove the bolts (1) securing the HV battery to the vehicle (Figure 26).

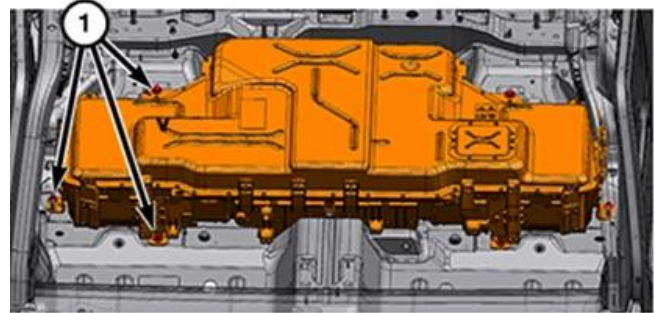

Figure 26 – HV Battery Bolts

- 41. Install two Eyebolt, 10mm 2035203080 with the nuts to the front support mounting holes (1) (Figure 27).

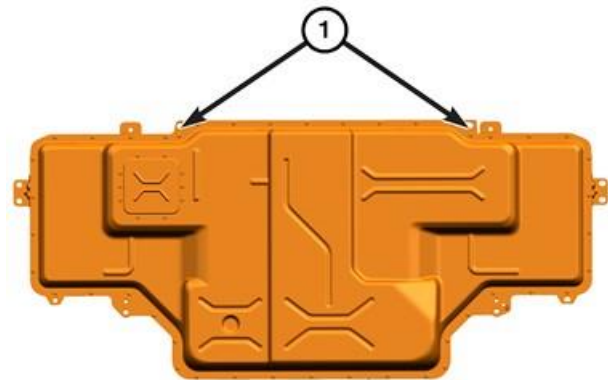

Figure 27 – Support Mounting Holes

- 42. Thread the other two Eyebolt, 10mm 2035203080 (1) into the threaded holes next to the HV battery pack mounting bolt holes (2) on the rear side of the HV battery pack (Figure 28).

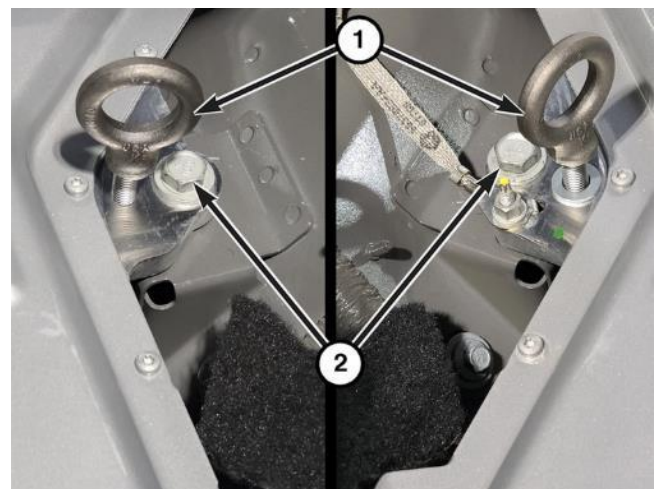

Figure 28 – Eyebolt Installation

43. Connect the Lift Straps, HV Battery 2035200080 to the eyebolts and the lifting device. Adjust the straps so that the battery will be level during lifting as shown in the picture (Figure 29).

44. Remove the HV battery pack from the vehicle.



Figure 29 – Lift Straps

NOTE: When the HV battery pack is being replaced:

- Refer to the information supplied with the **NEW** battery.
- **All coolant must be removed from the battery. Use a shop air supply hose connected to the battery coolant inlet port. Adjust the air pressure regulator to not exceed 100 kPa (15 psi) and force the coolant from the battery coolant outlet port.**
- **All coolant ports and electrical connections must be capped.**
- **Place the HV battery pack in the shipping container or in a suitable storage location properly supported to prevent damage to the underside of the battery.**

45. Attach the Eyebolt, 10mm 2035203080 to the new HV battery pack in the same locations that were used for the removal. Connect the Lift Straps, HV Battery 2035200080 on the front and rear eyelets.
46. Secure the HV battery pack to the lifting device.
47. Install the HV battery pack in the vehicle making sure that the mounting holes align with the bolt holes in the body.
48. Remove the lifting strap and eyebolts.
49. Install the HV battery pack bolts (1) and tighten to (Figure 26):
- High Voltage Battery to Chassis M10 Bolts tighten to 45N·m (33 ft. lbs.).
 - High Voltage Battery to Chassis M8 Bolts tighten to 21N·m (15 ft. lbs.).
50. Install the chassis ground cable to the HV battery ground stud (1) and tighten to 9N·m (80 in. lbs.) (Figure 23).

51. Connect the HV battery coolant line connectors (1) (Figure 25).
 52. Connect the three HV wire harness connectors (1) (Figure 24).
 53. Install the silencer pad (Figure 22).
 54. Install the rear seat to the vehicle.
 55. Install the bolts at the front of the rear seat and tighten to 70N·m (52 ft. lbs.).
 56. Connect the wire harness connectors, if equipped (Figures 20 and 21).
 57. Install the rear seat fasteners at the rear of the seat and tighten to 70N·m (52 ft. lbs.).
 58. Install the seat belts from the floor stud.
 59. Install the nut for the center seat belt anchor and tighten to 70N·m (52 ft. lbs.).
 60. Raise the rear seat cushion.
 61. Install the rear seat to load floor gap hider (Figure 19).
 62. Align and install the retainers from the front high voltage battery closeout to the vehicle (Figure 18).
 63. Install the high voltage trim panel and press downward to seat the retainers (Figure 17).
 64. Install the fasteners to the side high voltage battery trim panels and tighten securely.
 65. Lower the rear seat cushion.
 66. Set the door into place on the hinges and install the door hinge pivot nuts. Tighten the nuts to 6N·m (53 in. lbs.) (Figure 16).
 67. Install the door check strap bolt securing the door check and tighten to 9N·m (80 in. lbs.) (Figure 15).
 68. Connect the wire harness connector and secure the door tether to the support bracket (Figure 14).
 69. Align and install the B-pillar trim cover (Figure 13).
 70. Raise and support the vehicle.
- NOTE: When connecting the High Voltage connection verify that the connectors are clean and seated properly.**
71. Remove the battery port covers and transfer them to the old battery. Connect the HV wire harness connectors (1) and (2) to the HV battery and tighten to 9N·m (80 in. lbs.) (Figure 12).
 72. Install the battery skid plate (2) and tighten the fasteners (1) to 25N·m (18 ft. lbs.) (Figure 11).
 73. Install the power electronics cooling system coolant hoses (Figure 10).
 74. Install the air cleaner body (1) to the two lower rubber grommets and attach the clean air hose (Figure 9).

75. Connect the fuel vapor purge hose quick coupling (2) to the air cleaner body cover (Figure 6).
76. Connect the vacuum boost hose quick coupling (1) to the air cleaner body cover (Figure 6).
77. Install the front air dam (1) and eight push pin fasteners (Figures 4 and 5).
78. Remove the support and lower vehicle.
79. Power up the electrical system (Refer to the detailed procedures available in DealerCONNECT > Service Library > under: 12 - Electrified Powertrain System / High Voltage Battery / Standard Procedure / High Voltage Power Up).
80. With the scan tool, make sure that the BPCM software is fully up to date.
81. With the scan tool, perform the Enable HV Battery Contactors routine. (The vehicle will not start if this scan tool routine is not performed).
82. Check and fill the battery cooling system (Refer to the detailed procedures available in DealerCONNECT > Service Library > under: 12 - Electrified Powertrain System/Battery Cooling/Standard Procedure).
83. Using the scan tool, clear any DTCs.
84. Ensure vehicle operates as intended.
85. Perform **Section E: Install the Authorized Modifications Label**.
86. For California residents, perform **Section F: Complete Proof of Correction Form**.
87. Return the vehicle to the customer or inventory.

D. (WL) Jeep Grand Cherokee - High Voltage Battery Pack Replacement

Only individuals with high voltage training and repair qualifications should be allowed to handle, troubleshoot, or repair High Voltage (HV) or Hybrid components or systems.

1. Power down the electrical system (Refer to the detailed procedures available in DealerCONNECT > Service Library > under: 12 - Electrified Powertrain System / High Voltage Battery / Standard Procedure / High Voltage Power Down).
2. Raise and support the vehicle Raise and support the vehicle. (Refer to the detailed procedures available in DealerCONNECT > Service Library > under: 04 - Vehicle Quick Reference/Hoisting/Standard Procedure).
3. Remove the bolts securing the PHEV primary battery skid plate to vehicle (Figure 30).
4. Remove the PHEV primary battery skid plate from vehicle (Figure 30).
5. Remove the bolts securing the PHEV primary battery skid plate to vehicle (Figure 31).
6. Remove the PHEV primary battery skid plate from vehicle (Figure 31).

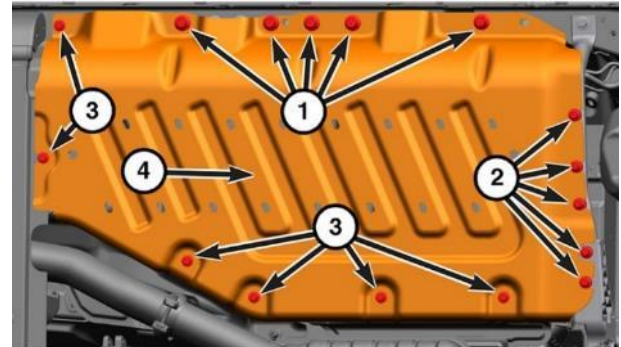

Figure 30 – Primary Battery Plate

- 1 - Battery Skid Plate to Underbody Bolts
- 2 - Battery Skid Plate to Bracket Bolts
- 3 - Battery Skid Plate to Sill Brace Bolts
- 4 - Primary Battery Skid Plate

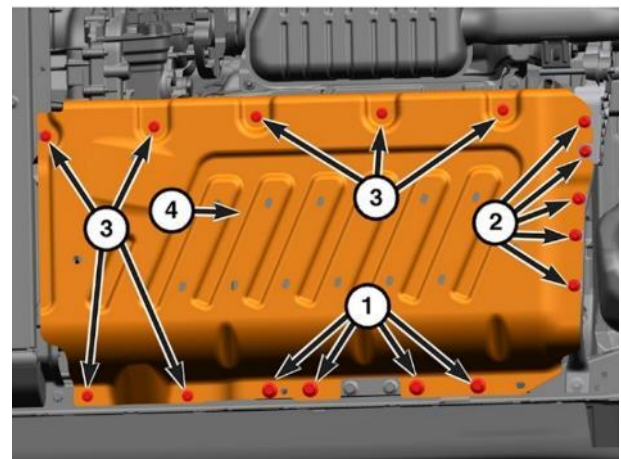

Figure 31 – Secondary Battery Skid Plate

- 1 - Battery Skid Plate to Underbody Bolts
- 2 - Battery Skid Plate to Bracket Bolts
- 3 - Battery Skid Plate to Sill Brace Bolts
- 4 - Secondary Battery Skid Plate

7. Remove the bolts securing the front suspension stabilizer bar skid plate to the vehicle (Figure 32).
8. Remove the front suspension stabilizer bar skid plate from vehicle (Figure 32).

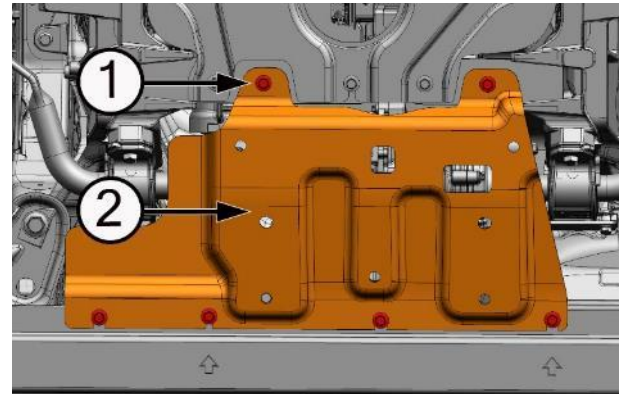

Figure 32 – Stabilizer Bar Skid Plate

- 1 - Stabilizer Bar Skid Plate Fasteners
- 2 - Stabilizer Bar Skid Plate

9. Support the exhaust system with a suitable jack stand.
10. Remove the two left front exhaust isolator bolts (Figure 33).
11. Remove the left rear exhaust isolator bolt (Figure 33).

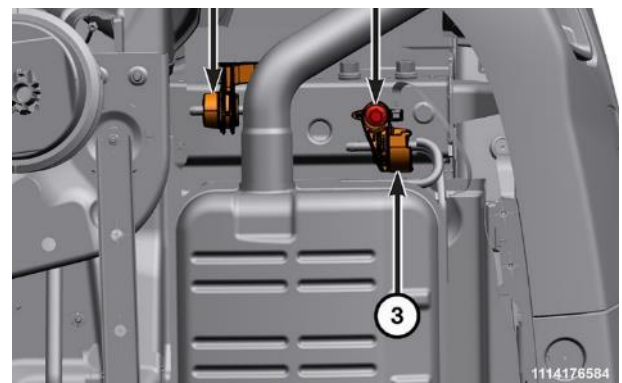

Figure 33 – Exhaust Isolators

- 1 - Left Front Exhaust Isolator
- 2 - Exhaust Isolator Bolt
- 3 - Left Rear Exhaust Isolator

12. Remove the two right front exhaust isolator bolt (Figure 34).

13. Remove the right rear exhaust isolator bolt (Figure 34).

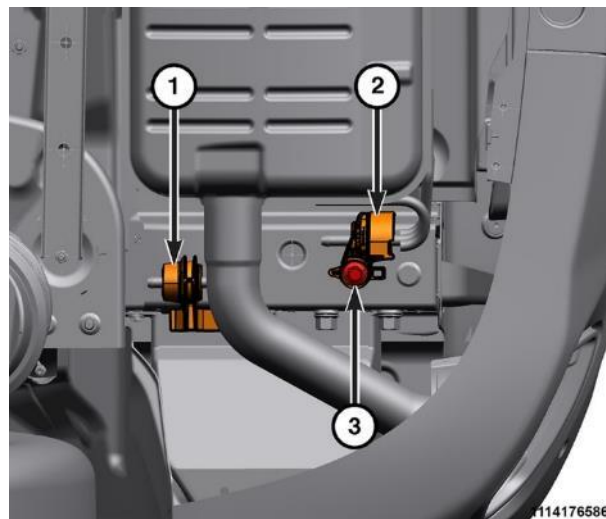

Figure 34 – Exhaust Isolators

- 1 - Right Front Exhaust Isolator
- 2 - Right Rear Exhaust Isolator
- 3 - Exhaust Isolator Bolt

14. Remove the two exhaust isolator bracket bolts (Figure 35).

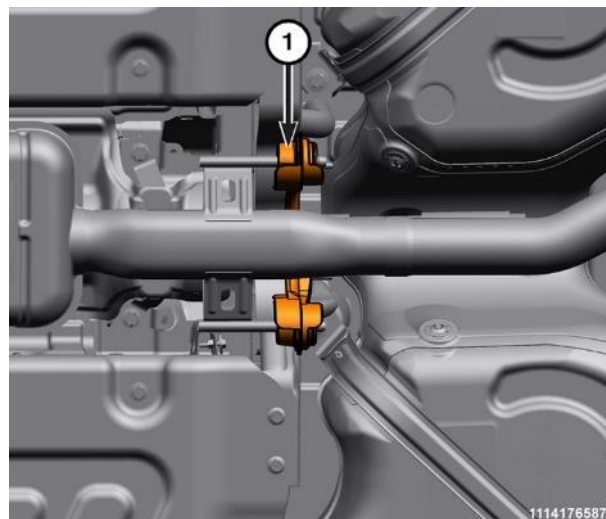

Figure 35 – Exhaust Isolators

- 1 - Exhaust Isolators

15. Loosen the exhaust resonator/muffler clamp nut (Figure 36).

16. With the help of an assistant, remove the exhaust resonator/muffler assembly (Figure 36).

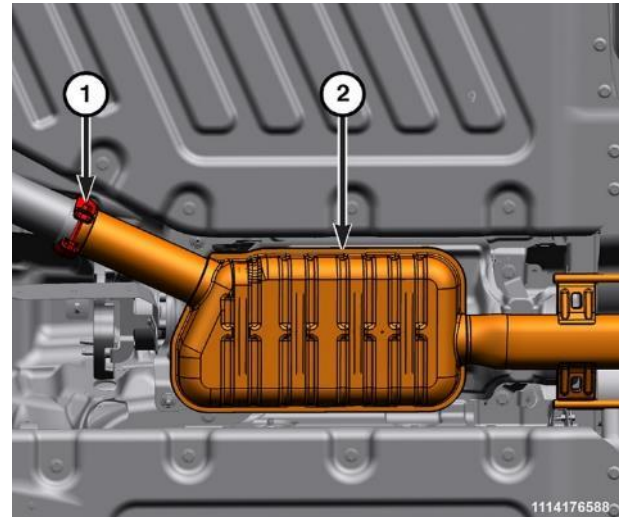

Figure 36 – Exhaust Resonator/Muffler

- 1 - Exhaust Resonator/Muffler Clamp Nut
- 2 - Exhaust Resonator/Muffler Assembly

17. Remove the center heat shield nuts, center heat shield to center support bearing bolts, and the center heat shield (Figure 37).

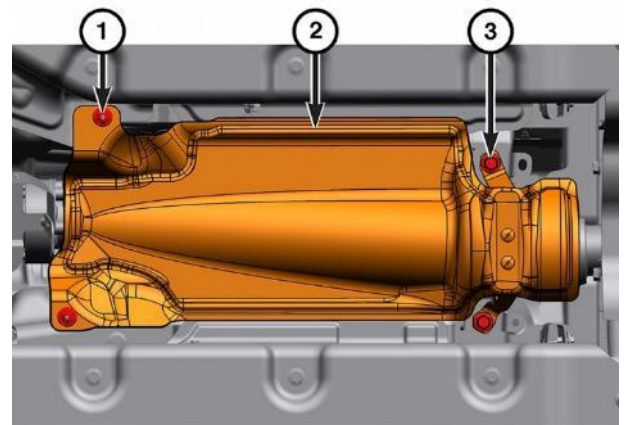

Figure 37 – Center Heat Shield

- 1 - Center Heat Shield Nuts
- 2 - Center Heat Shield
- 3 - Center Heat Shield to Center Support Bearing Bolts

18. Remove the front exhaust pipe isolator bolt to allow movement of the pipe. The pipe flex joint will allow the tail end of the pipe to be positioned aside for heat shield removal (Figure 38).

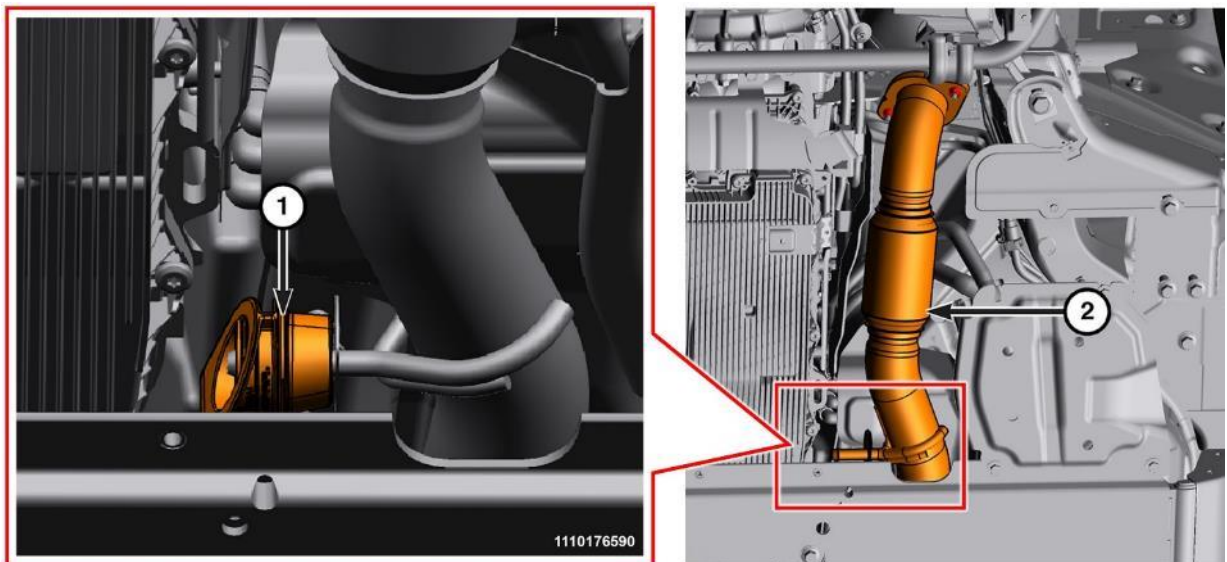

Figure 38 – Front Exhaust Pipe

- 1 - Exhaust Isolator
- 2 - Exhaust Pipe Flex Joint

19. Remove the nuts securing the front heat shield (Figure 39).
20. The front heat shield will need to be positioned aside however removal of the heat shield is not necessary.

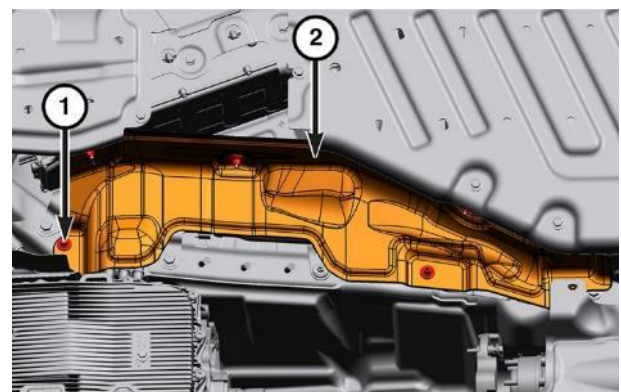
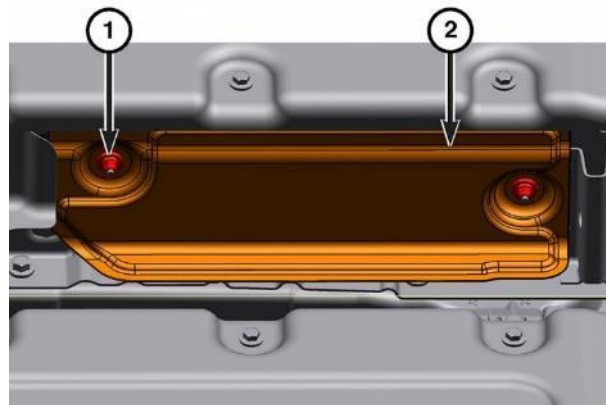

Figure 39 – Front Heat Shield

- 1 - Front Heat Shield Nuts
- 2 - Front Heat Shield

21. Remove the center left heat shield nuts, and the center left heat shield (Figure 40).



1113176602

Figure 40 – Center Left Heat Shield

- 1 - Center Left Heat Shield Nuts
2 - Center Left Heat Shield

22. Remove the center right heat shield nuts, and the center right heat shield (Figure 41).

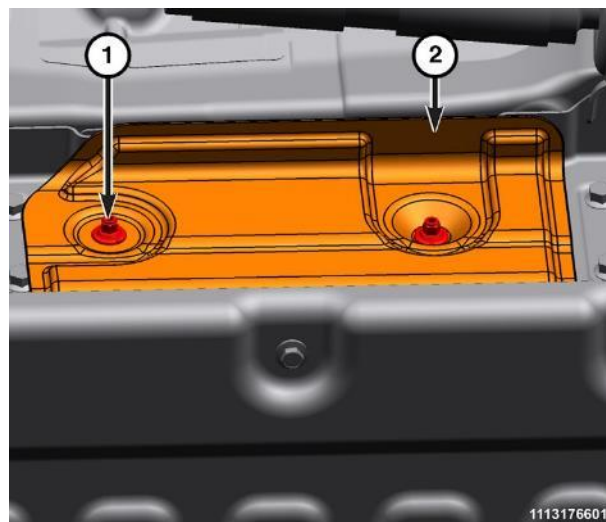

1113176601

Figure 41 – Center Right Heat Shield

- 1 - Center Right Heat Shield Nuts
2 - Center Right Heat Shield

SAFETY RECALL
NORTH AMERICA
High Voltage Battery



Reference: 95B / NHTSA 24V-720

FCA US LLC

23. All High and Low voltage connectors must be covered using the Covers, High Voltage Battery Terminal 2035100082 Kit.

24. Disconnect the low voltage wire harness connectors and cover (Figure 42).

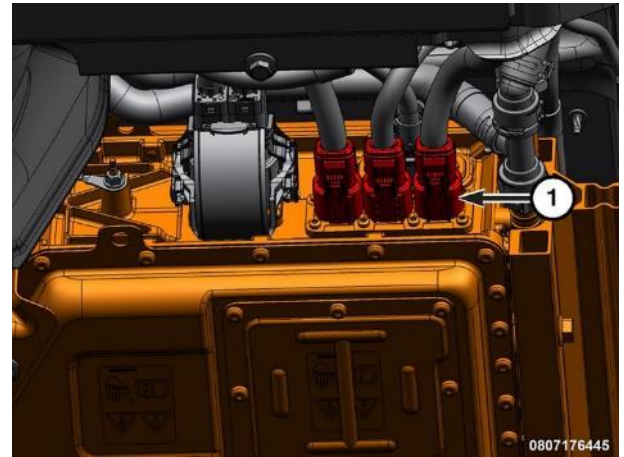

Figure 42 – HV Battery - Primary

1 - Low Voltage Wire Harness Connectors

25. Remove the fastener securing the HV battery cable (Figure 43)

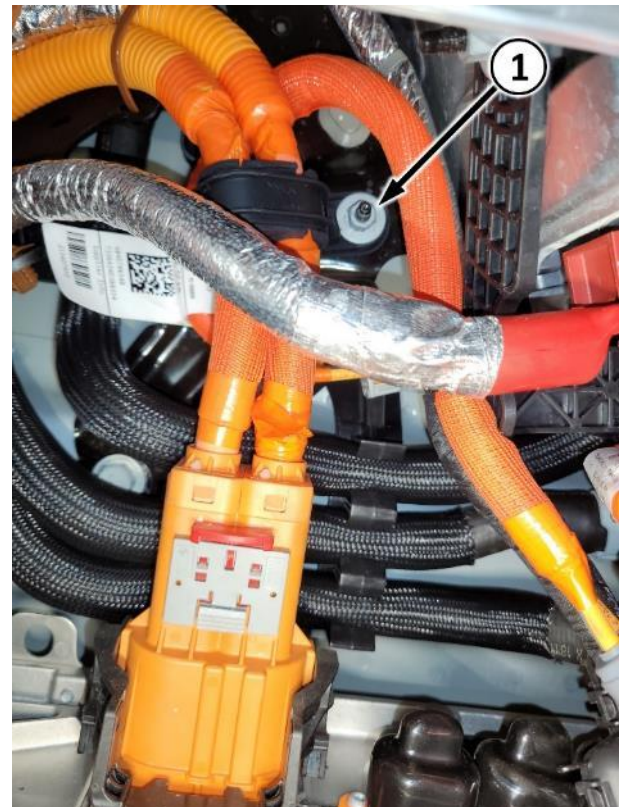

Figure 43 – HV Battery - Primary

1 - Fastener

- 26. Disconnect and install protective covers on the high voltage cable connector (Figure 44).
- 27. Disconnect and install protective covers on the low voltage wire harness connector (Figure 44).

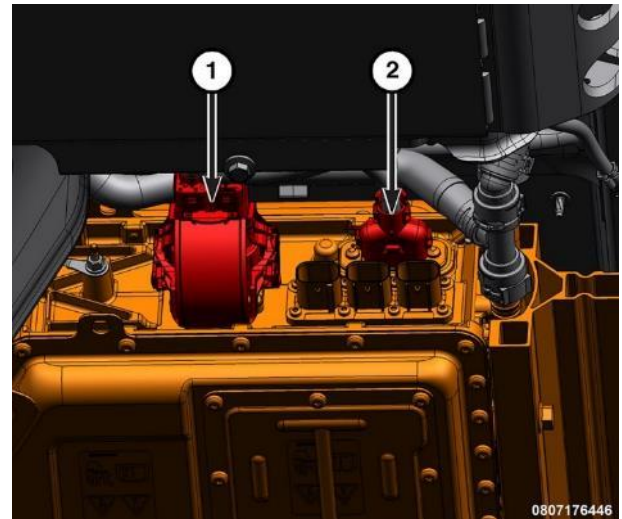

Figure 44 – HV Battery - Primary

- 1 - High Voltage Connector
- 2 - Low Voltage Wire Harness Connector

- 28. Using suitable container and pliers, clamp the coolant hose and disconnect the coolant line quick-connect fitting (Figure 45).
- 29. Remove the bolt that secures the ground cable (Figure 45).

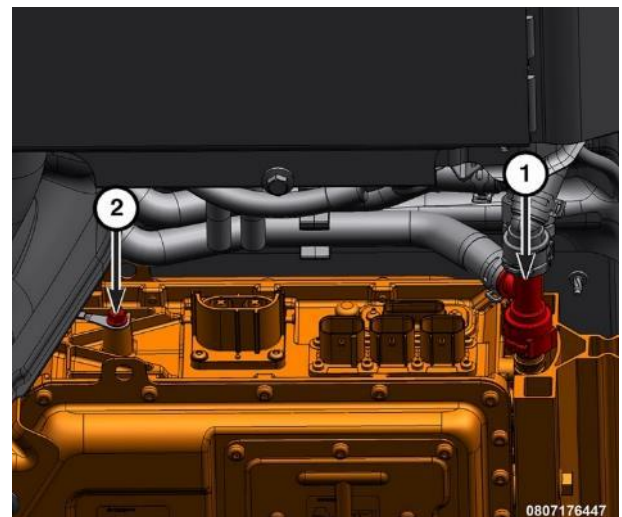

Figure 45 – HV Battery - Primary

- 1 - Coolant Line Quick-Connect Fitting
- 2 - High Voltage Battery Chassis Ground Cable Bolt

30. Release the wire harness retainers (Figure 46).

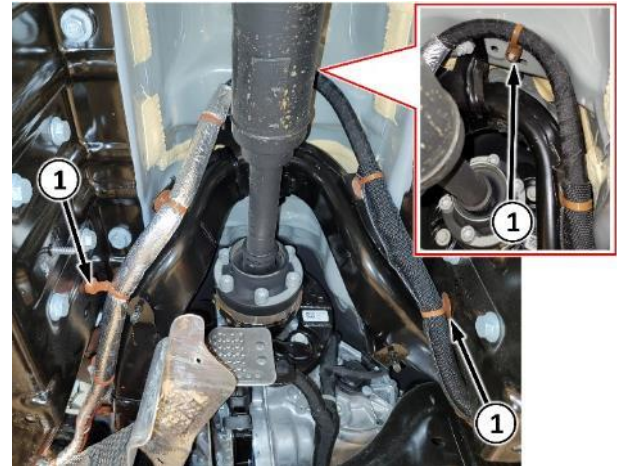

Figure 46 – HV Battery Harness

1 - Wire Harness Retainers

31. Remove the fasteners that secure the HV battery harness to the body and position aside (Figure 47).

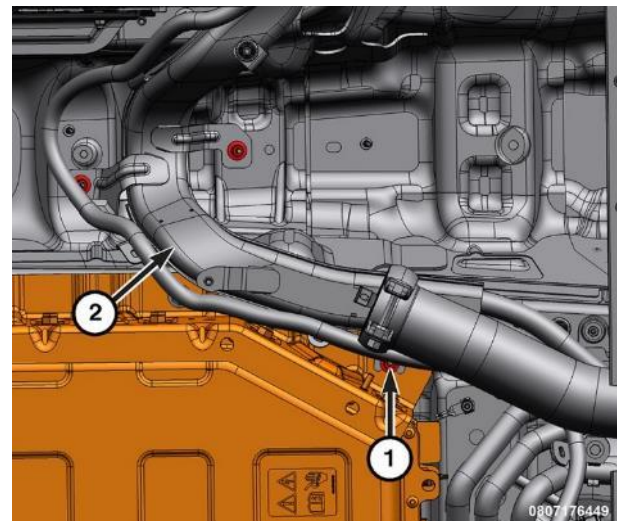

Figure 47 – HV Battery - Primary

1 - High Voltage Trough to Body Bolts

2 - High Voltage Battery Harness

- 32. Loosen the bolts securing the skid plate braces (Figure 48).

NOTE: The bolt holes in the braces are slotted. It is not necessary to fully remove the bolts.

- 33. Remove the braces from the vehicle (Figure 48).

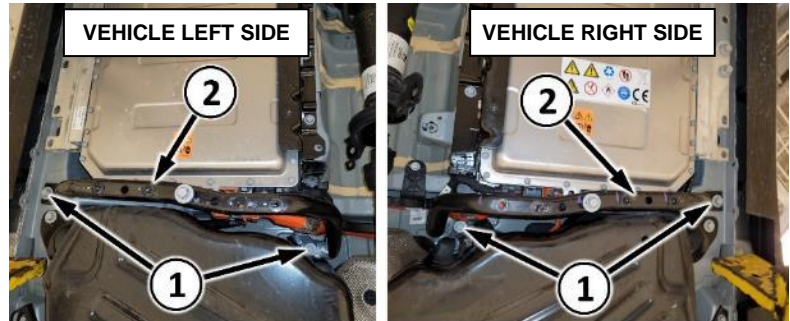

Figure 48– HV Battery Skid Plate Braces

- 1 - Bolts
- 2 - Skid Plate Braces

- 34. Disconnect and install protective covers on the HV cable connector and the LV wire harness connector at the rear of the battery (Figure 49).

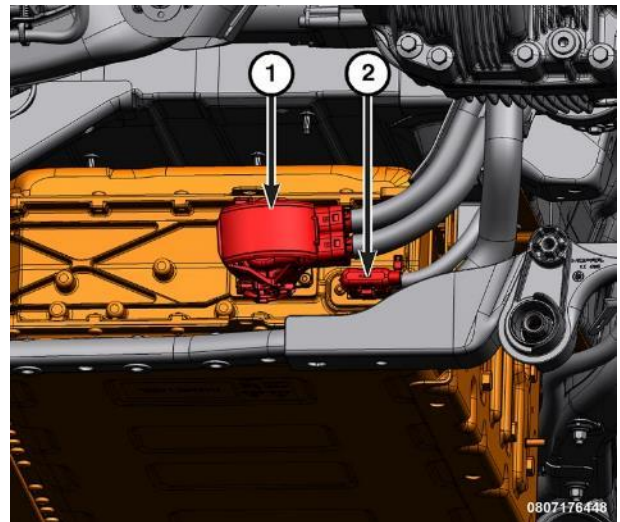

Figure 49 – HV Battery - Primary

- 1 - High Voltage Battery Cable Connector
- 2 - Low Voltage Wire Harness Connector

- 35. Disconnect and cover the low voltage wire harness connector (Figure 50).
- 36. Disconnect and cover the HV cable connector (Figure 50).

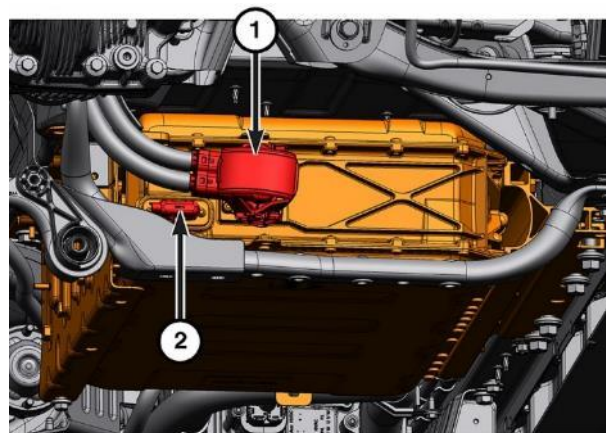

Figure 50 – HV Battery - Secondary

- 1 - High Voltage Cable Connector
- 2 - Low Voltage Wire Harness Connector

- 37. Remove the fasteners securing the HV battery jumper harness (Figure 51).
- 38. Remove the HV battery jumper harness from the vehicle (Figure 51).

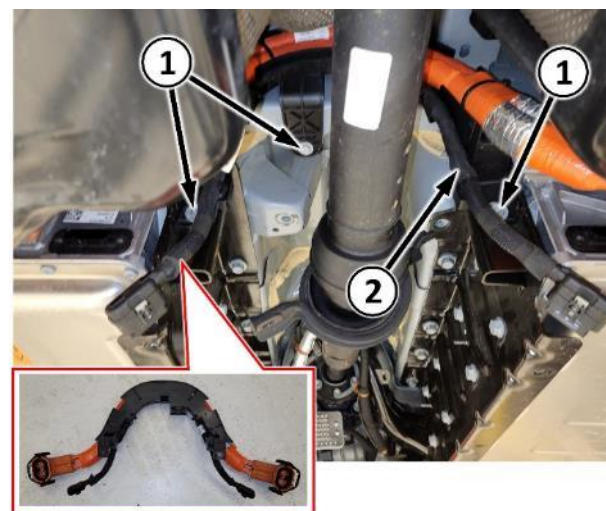

Figure 51 – HV Battery Jumper Harness

- 1 - Fasteners
- 2 - Jumper Harness

39. Using Table, Bishamon Lift BX50-CHR or suitable lift, remove the bolts securing the HV battery to the vehicle and remove the primary battery from the vehicle (Figure 52).

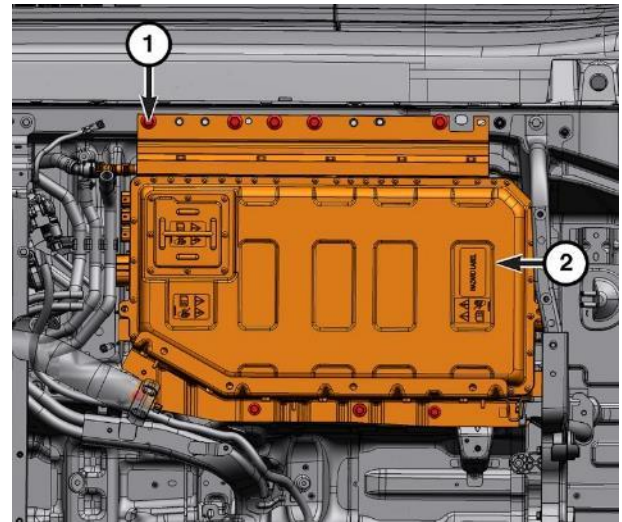

Figure 52 – HV Battery - Primary

- 1 - High Voltage Battery to Body Bolts
2 - Primary High Voltage Battery

40. Remove the four fasteners securing the wire bracket to the front of the HV secondary battery (Figure 53).

NOTE: The wire harness bracket does not need to be removed from the vehicle, just detached from the battery to allow for battery removal clearance.

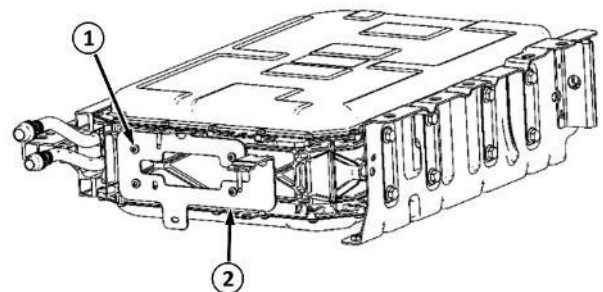

Figure 53 – HV Battery - Secondary

- 1 - Fasteners
2 - Wire Harness Bracket

41. Using suitable container and pliers clamp the coolant hoses and disconnect the coolant line quick connect fittings (Figure 54).
42. Remove the nuts securing the wiring harness and wire harness trough then set the harness aside (Figure 54).

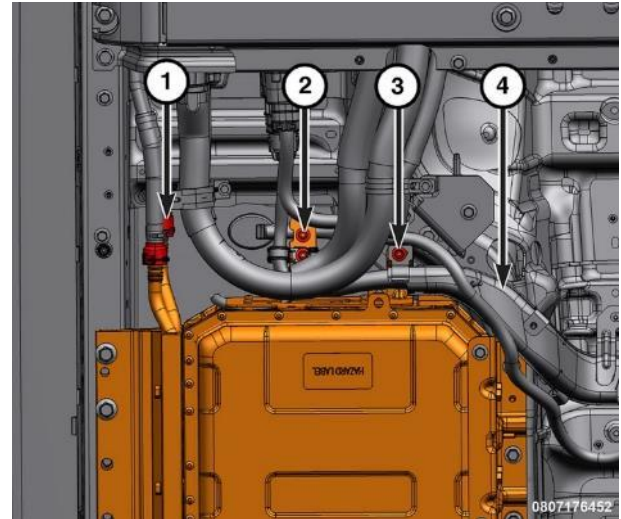

Figure 54 – HV Battery - Secondary

- 1 - Cooling Tube Quick-Connect Fittings
- 2 - HV PIM Harness to High Voltage Battery Nuts
- 3 - HV Wire Harness Trough Nut
- 4 - HV Wire Harness Trough

43. Using Table, Bishamon Lift BX50-CHR or a suitable lift, remove the fasteners securing the HV battery to the vehicle and remove the secondary battery from the vehicle (Figure 48).

44. Place the HV battery pack in the shipping container.

NOTE: If the HV battery is missing the return instructions, contact the UPS Call Center 800-567-9989.

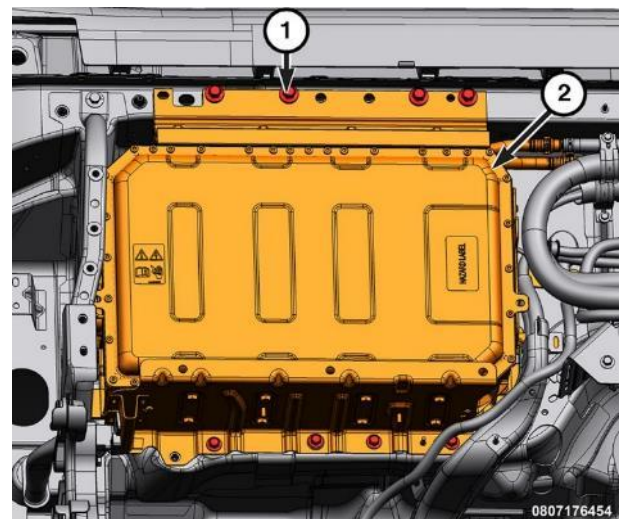

Figure 55 – HV Battery - Secondary

- 1 - High Voltage Battery to Body Bolts
- 2 - Secondary Battery

45. Place the new HV secondary battery on the Table, Bishamon Lift BX50-CHR or a suitable lift.
46. Position the HV secondary battery in the vehicle making sure that the mounting holes align with the bolt holes in the body.
47. Install the fasteners securing the HV secondary battery to the vehicle and tighten to 80 N·m (59 Ft. Lbs.) (Figure 55).
48. Install four fasteners securing the wire bracket to the front of the HV secondary battery and tighten the fasteners securely (Figure 53).
49. Install the nuts securing the wiring harness and wire harness trough. Tighten the nuts to 5 N·m (44 In. Lbs.) (Figure 54).
50. Connect the coolant line quick connect fittings to the secondary battery then remove the coolant hose clamp pliers (Figure 54).
51. Place the new HV primary battery on the Table, Bishamon Lift BX50-CHR or a suitable lift.
52. Position the HV primary battery in the vehicle making sure that the mounting holes align with the bolt holes in the body.
53. Install the fasteners securing the HV primary battery to the vehicle and tighten to 80 N·m (59 Ft. Lbs.) (Figure 52).
54. Install the HV battery jumper harness. Tighten the upper body fasteners to 6 N·m (53 In. Lbs.) and two lower battery fasteners to 8 N·m (71 In. Lbs.) (Figure 51).
55. Connect the secondary battery HV cable connector (Figure 50).
56. Connect the secondary battery low voltage wire harness connector (Figure 50).
57. Connect the HV cable connector and the LV wire harness connector at the rear of the primary battery (Figure 49).
58. Install the skid plate braces. Tighten the bolts to 55 N·m (40 Ft. Lbs.) (Figure 48).
59. Install the fasteners that secure the HV battery harness trough to the body. Tighten the nuts to 5 N·m (44 In. Lbs.) (Figure 47).
60. Install the wire harness retainers (Figure 46).
61. Install the bolt that secures the ground cable. Tighten the bolt to 9 N·m (80 In. Lbs.) (Figure 45).
62. Connect the coolant line quick connect fittings to the primary battery then remove the coolant hose clamp pliers (Figure 45).
63. Connect the low voltage wire harness connector to the primary battery (Figure 45).
64. Connect the high voltage cable connector to the primary battery (Figure 44).
65. Install the fastener securing the HV battery cable (Figure 43)

66. Connect the low voltage wire harness connectors to the primary battery (Figure 42).
67. Install the center right heat shield and nuts. Tighten the nuts to 5 N·m (44 In. Lbs.) (Figure 41).
68. Install the center left heat shield and nuts. Tighten the nuts to 5 N·m (44 In. Lbs.) (Figure 40).
69. Install the front heat shield and nuts. Tighten the nuts to 5 N·m (44 In. Lbs.) (Figure 39).
70. Install the front exhaust pipe isolator bolt. Tighten the bolt to 25 N·m (18 Ft. Lbs.) (Figure 38).
71. Install the center heat shield and nut. Tighten the nuts to 5 N·m (44 In. Lbs.) (Figure 37).
72. Position the center heat shield. Install the center heat shield nuts and center support bearing bolts. Tighten the center support bearing bolts to 55 N·m (41 Ft. Lbs.) Tighten the heat shield nuts to 5 N·m (44 In. Lbs.) (Figure 37).
73. With the help of an assistant, install the exhaust resonator/muffler assembly (Figure 36).
74. Tighten the exhaust resonator/muffler clamp nut to 30 N·m (22 Ft. Lbs.) (Figure 36).
75. Install the two exhaust isolator bracket bolts and tighten to 25 N·m (18 Ft. Lbs.) (Figure 35).
76. Install the right rear exhaust isolator bolt and tighten to 25 N·m (18 Ft. Lbs.) (Figure 34).
77. Install the two right front exhaust isolator bolt and tighten to 25 N·m (18 Ft. Lbs.) (Figure 34).
78. Install the left rear exhaust isolator bolt and tighten to 25 N·m (18 Ft. Lbs.) (Figure 33).
79. Install the two left front exhaust isolator bolt and tighten to 25 N·m (18 Ft. Lbs.) (Figure 33).
80. Install the stabilizer bar skid plate and bolts. Tighten the bolts to 18 N·m (13 Ft. Lbs.) (Figure 32).

81. Install the secondary battery skid plate(s) and bolts. Tighten the bolts to torque specified in (Figure 56).
82. Install the primary battery skid plate(s) and bolts. Tighten the bolts to torque specified in (Figure 56).
83. Install the exhaust system heat shields as necessary (Refer to the detailed procedures available in DealerCONNECT > Service Library > under: 11 - Exhaust System / SHIELD, Heat / Removal and Installation).
84. Lower the vehicle.
85. Power up the electrical system (Refer to the detailed procedures available in DealerCONNECT > Service Library > under: 12 - Electrified Powertrain System / High Voltage Battery / Standard Procedure / High Voltage Power Up).
86. With the scan tool, make sure that the BPCM software is fully up to date.
87. With the scan tool, perform the Enable HV Battery Contactors routine. (The vehicle will not start if this scan tool routine is not performed).
88. Check and fill the battery cooling system (Refer to the detailed procedures available in DealerCONNECT > Service Library > under: 12 - Electrified Powertrain System/Battery Cooling/Standard Procedure).
89. Using the scan tool, clear any DTCs.
90. Ensure vehicle operates as intended.
91. Perform **Section E: Install the Authorized Modifications Label**.
92. For **California residents**, perform **Section F: Complete Proof of Correction Form**.
93. Return the vehicle to the customer or inventory.

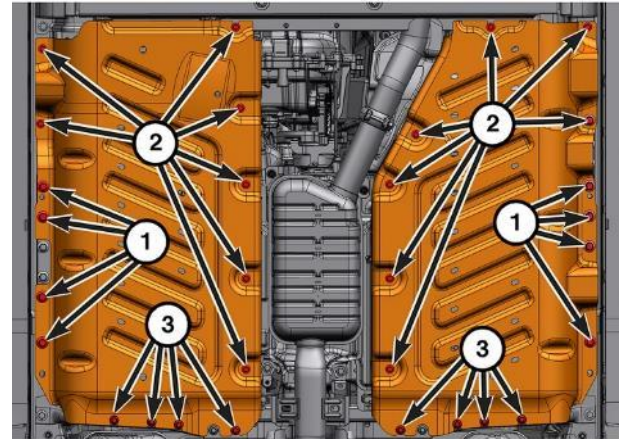

Figure 56 – HV Battery Skid Plates

- 1 - 80 N·m (60 Ft. Lbs.)
- 2 - 25 N·m (18 Ft. Lbs.)
- 3 - 25 N·m (18 Ft. Lbs.)

E. Install the Authorized Modifications Label:

Type or print (with a ballpoint pen) the necessary information on the Authorized Modifications Label. Then attach the label near the VECI label.

Chrysler Group LLC	AUTHORIZED MODIFICATIONS	THESE MODIFICATIONS HAVE BEEN APPROVED AS APPROPRIATE BY EPA AND CARB.
THE FOLLOWING MODIFICATIONS HAVE BEEN MADE:		
CHANGE AUTHORITY	DEALER CODE	DATE
RECALL	XXXXX	XX / XX / XXXX
04275086AD		







F. Complete Proof of Correction Form for California Residents:

This recall is subject to the **State of California Registration Renewal/Emissions Recall Enforcement Program**. Complete a Vehicle Emission Recall Proof of Correction Form (**Form No. 81-016-1053**) and **supply it to vehicle owners residing in the state of California** for proof that this recall has been performed when they renew the vehicle registration.

Process Steps to obtain the California Proof of Correction form:

- a. Access the **“DealerCONNECT”** website.
- b. Select the **“Service”** tab.
- c. Under the **“Publications”** heading, select the **“ePublishing”** link.
- d. Sign in using your **Dealer Code** and **Password**.
- e. Select the **“Proof of Correction form”**.

Drive Cycle Sequence Reference Sheet:

Accelerate To:	Coast To:
 35	 25
 40	 30
 45	 35
 50	

This notice applies to your vehicle,

[Model Year and Model]

VIN XXXXXXXXXXXXXXXXXXXX

95B/NHTSA 24V-720

LOGO

VEHICLE PICTURE

YOUR SCHEDULING OPTIONS

1. RECOMMENDED OPTION

Call your authorized Chrysler / Dodge / Jeep® / RAM Dealership.

2. Call the FCA Recall Assistance Center at 1-800-853-1403. An agent can confirm part availability and help schedule an appointment.

3. Visit recalls.mopar.com, scan the QR code below, or download the Mopar Owner's Companion App.

QR Code

Get access to recall notifications, locate your nearest dealer, and more through this website or Mopar Owner's Companion App. You will be asked to provide your Vehicle Identification Number (VIN) to protect and verify your identity. The last eight characters of your VIN are provided above.

DEALERSHIP INSTRUCTIONS

Please reference Safety Recall 95B.

IMPORTANT SAFETY RECALL

High Voltage Battery

Dear [Name],

This notice is sent to you in accordance with the National Traffic and Motor Vehicle Safety Act.

Owners of vehicles previously notified of the B9A recall (NHTSA 23V-787) will need to bring their vehicle in for recall completion, regardless of having the B9A repair performed.

FCA US LLC has decided that a defect, which relates to motor vehicle safety, exists in certain [2020 - 2024 model year (JL) Jeep Wrangler and 2022 - 2024 model year (WL) Jeep Grand Cherokee] Plug-In Hybrid Electric Vehicles (PHEVs).

It is extremely important to take steps now to repair your vehicle to ensure the safety of you and your passengers.

WHY DOES MY VEHICLE NEED REPAIRS?

The High Voltage (HV) battery pack in your vehicle ^[1] may have been built with cells which are susceptible to separator damage. Separator damage, combined with other complex interactions within the cells, may lead to a vehicle fire. **A vehicle fire can result in increased risk of occupant injury and/or injury to persons outside the vehicle, as well as property damage.**

Vehicle risk is reduced when the battery charge level is depleted. Accordingly, owners are advised to refrain from recharging. Out of an abundance of caution, FCA US is also advising owners of these vehicles to park away from structures or other vehicles until the remedy is obtained.

HOW DO I RESOLVE THIS IMPORTANT SAFETY ISSUE?

FCA US LLC will repair your vehicle ^[2] free of charge (parts and labor). To do this, your dealer will reprogram the battery pack control module with new software followed by a HV battery replacement if needed. The estimated repair time for software update is two hours. More time will be required if HV battery replacement if needed. In addition, your dealer will require your vehicle for proper check-in, preparation, and check-out during your visit, which may require more time. Your time is important to us, so we recommend that you schedule a service appointment to minimize your inconvenience. Ask your dealer for alternate transportation options while your vehicle is in service. Please bring this letter with you to your dealership.

**TO SCHEDULE YOUR FREE REPAIR,
CALL YOUR CHRYSLER, DODGE, JEEP OR RAM DEALER TODAY**

WHAT IF I ALREADY PAID TO HAVE THIS REPAIR COMPLETED?

If you have already experienced this specific condition and have paid to have it repaired, you may visit www.fcarecallreimbursement.com to submit your reimbursement request online. ^[3] Once we receive and verify the required documents, reimbursement will be sent to you within 60 days. If you have had previous repairs performed and/or already received reimbursement, you may still need to have the recall repair performed.

We apologize for any inconvenience, but are sincerely concerned about your safety. Thank you for your attention to this important matter.

Customer Assistance/Field Operations
FCA US LLC



Mr. Mrs. Customer
1234 Main Street
Hometown, MI 48371

[1] If you no longer own this vehicle, please help us update our records. Call the FCA Recall Assistance Center at 1-800-853-1403 to update your information.

[2] If your dealer fails or is unable to remedy this defect without charge and within a reasonable time, you may submit a written complaint to the Administrator, National Highway Traffic Safety Administration, 1200 New Jersey Ave., S.E., Washington, DC 20590, or you can call the toll-free Vehicle Safety Hotline at 1-888-327-4236 (TTY 1-800-424-9153), or go to safercar.gov.

[3] You can also mail in your original receipts and proof of payment to the following address for reimbursement consideration: FCA Customer Assistance, P.O. Box 21-8004, Auburn Hills, MI 48321-8007, Attention: Recall Reimbursement.

Note to lessors receiving this recall notice: Federal regulation requires that you forward this recall notice to the lessee within 10 days.