

## **UPDATE: Recall 24V-716 Delivery Stop R18 Model's Control Unit Reverser**

Recall 24V-716 with final repair has been posted for R 18 reverser

UPDATE: Feb 24th 2025:

[RECALL 24V-716: 61 03 25 R 18 Reverser](#) Bulletin has been released today Feb 24th 2025.

This bulletin **supersedes** the interim repair **bulletin 61 09 24 "Deactivating reverser control unit"**

Because the release of this RECALL, **all** affected motorcycles have been placed under the delivery stop **STOP610019** associated with the current campaign number **0000612300**, which will be lifted upon completion of this campaign.

Part 61 35 5 B73 A31 Cable retrofit kit (only to be ordered for a vehicle that had the reverser deactivated) has been placed under a YOCV campaign ordering process, documented in the SIB and attached here.

NOTE: Hyperlink takes you to TIS 2.0. If you not logged into TIS 2.0 this will take you to the login page. Once logged in select the hyperlink again and this will take you directly to the SIB in TIS.

Update Oct 9th 2024:

Due to a system error, some units **WITHOUT** Reverser option (5AA) were affected by this recall.

This system error has been corrected and the affected VIN's have been updated.

Approximately **89 units** (R 18, R 18 Classic, R 18 Bagger and R 18 Roctane models without reverser option (5AA)) **have been removed from the recall.**

Please double check your inventory.

---

Update Sept 27th 2024:

- Defect code changed from STOP610019 to 0000611900.
- Added NHTSA Statement
- [SIB 61 09 24 RECALL 24V-716: Disable Reverser](#) has been released in TIS 2.0.

NOTE: Hyperlink takes you to TIS 2.0. If you not logged into TIS 2.0 this will take you to the login page. Once logged in select the hyperlink again and this will take you directly to the SIB in TIS.

**NHTSA STATEMENT**

Please be reminded that it is a violation of federal law (The Safety Act) for you to sell, lease or deliver any new motorcycle covered by this notification until the recall repair has been performed. This means that dealers may not legally deliver new motorcycles to consumers until they are fixed or use/sell replacement equipment/parts subject to this recall. Note also that substantial civil penalties apply to violations of the Safety Act. Also, you should not sell, lease or deliver any used motorcycles subject to a safety recall until the repair is completed. Please follow any special instructions that we provide to you for the return or disposition of recall parts.

---

BMW is announcing a delivery stop STOP610019 for R18 (K34), R18 Classic (K34), R18 Roctane (K34) ,R18 Bagger (K35), R18 Transcontinental (K35), equipped with Option 05AA - Backup Assistant produced between Nov. 21 st, 2021 to Jul. 11 th, 2024.

After a quality inspection it was found that humidity can enter the reverser control unit and cause corrosion of internal electrical contacts over time. This corrosion can cause the reverser to fail and in rare cases additional damage may occur.

Affected vehicles are flagged in AIR (Aftersales Information Research) with campaign code 00 00 61 19 00. Please note, open campaigns or vehicle stops may not appear in DCS Warranty Vehicle Inquiry or sales systems until 24-72 hours after they are announced, therefore AIR is always the recommended method for determining open campaigns and vehicle stops.

If you have a vehicle in your new/used inventory matching the above description it cannot be retailed until repaired. Make sure you check your inventory in AIR before retail.

Next steps are being determined and a bulletin with technical measures will be published once information is available.

Feb 24, 2025



## SIB 61 03 25 RECALL 24V-716: R 18 Reverser

2025-02-24

This Service Information Bulletin replaces SIB 61 09 24 posted Jan 24, 2025.

### MODEL

Model	Model Description	Model Code
K34	R 18	0L13
K34	R 18 Classic	0L23
K34	R 18 Roctane	0N63
K35	R 18 Bagger	0L33
K35	R 18 Transcontinental	0L43

The affected vehicles have been marked with campaign number **0000612300** in AIR.

In order to determine if a specific motorcycle is affected by this campaign, it will be necessary to verify the vehicle VIN in AIR (Aftersales Information Research). Based on the response of the system, either proceed with the repair or take no further action. Please note, open campaigns or vehicle stops may not appear in DCS Warranty Vehicle Inquiry or sales systems until 24-72 hours after they are announced, therefore AIR is always the recommended method for determining open campaigns and vehicle stops.

### SITUATION

After quality inspection, BMW Motorrad has found that due to insufficient sealing of the reverser control unit, moisture can leak into the control unit. This can lead to corrosion of electrical contacts inside the control unit over time and under certain warm-humid (all year round) climatic conditions. This corrosion can result in a failure of the reverser function.

In rare cases, increased electrical resistance can occur between the corroded contacts, resulting in overheating of the components that could develop into thermal damage to the control unit.

The affected motorcycles have been placed under the delivery stop **STOP610019** associated with campaign number 0000612300, which will be lifted upon completion of this technical campaign.

The interim solution that was released on affected motorcycles was assigned Service Information Bulletin (SIB) "61 09 24 Recall 24V-716 - Deactivating reverser control unit". **The final remedy is now available, and the interim solution is no longer permissible.**

**Customer compensation has not changed and is still not permissible for units repaired with a repair date after 01/31/2025.**

### PROCEDURE

For vehicles that have not been delivered, the Recall must be carried out before delivery to customers.

For motorcycles already retailed, letters are being mailed to owners via First Class mail advising them of this recall and asking them to schedule an appointment with an authorized BMW Motorrad dealer to have the recall performed.

**For motorcycles on which "61 09 24 Recall 24V-716 - Deactivating reverser control unit" was carried out and the reverser control unit was temporarily deactivated, the cable retrofit kit must be**

**installed.** The steps required for this are described in repair instructions “00 60 447 – Installing additional wiring harness with relay”.

On all affected motorcycles, an additional wiring harness with protective relay for reverser control unit must be installed in accordance with repair instructions “00 60 447 - Installing additional wiring harness with relay”. The article number of the main wiring harness must be noted.

The software version of the motorcycle must be programmed to a current I level in accordance with model-specific repair instructions “61 00 510 – Programming vehicle control units”, at least to **I level K001-24-11-512** has been available since ISTA version 4.50.40 released 4/12/2024.

**NOTE:** It is essential to make sure that the **FASTA data is transferred correctly to the back end.** FASTA data is used as evidence for the correct performance of the recall in warranty accounting to prevent a debit. If the software update is not performed or performed incorrectly (not using the correct ISTA version), the claim will be debited, and the recall will be reopened on the corresponding VIN.

## **NHTSA STATEMENT**

Please be reminded that it is a violation of federal law (The Safety Act) for you to sell, lease or deliver any new motorcycle covered by this notification until the recall repair has been performed. This means that dealers may not legally deliver new motorcycles to consumers until they are fixed or use/sell replacement equipment/parts subject to this recall. Note also that substantial civil penalties apply to violations of the Safety Act. Also, you should not sell, lease or deliver any used motorcycles subject to a safety recall until the repair is completed. Please follow any special instructions that we provide to you for the return or disposition of recall parts.

## **PARTS INFORMATION**

Obtain and confirm the part numbers for your specific motorcycle by entering the chassis number in ETK/EPC which takes into account specific equipment and/or options.

Additional parts like gaskets, hardware and chemicals may be required for the complete repair.

**NOTICE:** Make sure when scheduling a vehicle for this repair to check WVI for the completion of the previous interim repair per SIB 61 09 24 before ordering so you know to order the cable retrofit kit or not.

### **YOCV Order Information:**

The Cable Retrofit Kit for reverser control unit is only necessary for the units that had the reverser removed per SIB 61 09 24 and QTY will be limited because of this, we implemented the YOCV ordering for this part only.

Orders for the Cable retrofit kit for reverser control unit can be placed with the special campaign ordering process outlined below and will be released as parts arrive. This new process will be used for the entire campaign.

**PLEASE FOLLOW THE BELOW PROCEDURE FOR ORDERING PARTS. IDS TICKETS ARE NOT NECESSARY TO OBTAIN PARTS. Each VIN can only be ordered once. Do not place an order for a customer’s bike unless the bike is at the dealership, or the customer has scheduled an appointment.**

YOCV Campaign Number: 3104756132

Parts for this category should be ordered using the “YOCV Campaign” order type function in DCSnet. Attached you will find step by step instructions for placing this order with this order type. You will need to order by the below campaign number using the full VIN of the relevant motorcycle.

Copyright ©2025 MOTORRAD USA, a division of BMW of North America, LLC. All Rights Reserved

Only the (PART Description) will be allocated through the Campaign System. The remaining required parts are common parts and should be ordered by dealers as needed through normal parts ordering process.

If you have an ordering issue using the above process, please open an IDS Ticket including the VIN and detailed description.

Order using the YOCV Campaign number: 3104756132

### Parts requiring YOCV Campaign ordering:

61 35 5 B73 A31	Cable retrofit kit for reverser control unit ( <b>ONLY if cable was removed under SI 61 09 24 Recall 24V-716 - Deactivating reverser control unit</b> )	1
-----------------	---	---

Note: You will notice the main cable in the retrofit kit has an inline fuse incorporated. This fuse is not a required item; however, the cable was produced with the inline fuse and is not considered a design change or upgrade from the original cable. This new cable retrofit kit should only be ordered if the original cables were removed per the interim repair in SIB 61 09 24. This cable retrofit kit is only produced for this campaign and will not be stocked as a regular part in the future.

### Parts not requiring YOCV ordering that can be ordered via regular part ordering process:

61 12 5 B6F DD6	Protective relay additional wiring harness for reverser control unit	1
61 12 5 B70 FC9	Protective relay additional wiring harness for reverser control unit - <b>ONLY for the following main wiring harness article number (K34 model year 2020, 2021): 61 11 1 542 498</b>	1
61 13 5 B70 327	Relay holder	1
61 13 5 B70 2F7	Relay protective cap	1
07 12 9 907 195	ISA screw (M6×18-8.8)	2
61 13 1 378 964	Plug connection holder	1
61 13 8 383 139	Insulating cap	1
07 12 9 908 527	Cheese head screw (M10×30-10.9-MK)	2
46 63 8 534 943	Body screw without collar (M5 × 14 MK)	3

## CLAIM INFORMATION

Please submit claims via the normal claim process using the information below:

### Defect code

00 00 61 23 00	Retrofitting protective relay for reverser control unit
----------------	---

### Labor Operation

00 60 447	Installing additional wiring harness with relay	8 FRU
+00 60 947	Installing additional wiring harness with relay	7 FRU
+ 00 60 843	Additional installing cable retrofit kit (if necessary)	1 FRU

FRUs includes all repair procedures to complete the task with allowance for necessary ancillary tasks (e.g., visual inspection, lubrication, cleaning parts etc.) and administrative tasks.

Labor operation code 00 60 447 is a Main labor operation. If you are using a Main labor code for another repair, use the Plus code labor operation instead.

### TREAD Act Reimbursement - Qualifying Prior Customer-Pay Repairs

If your center is presented with a reimbursement request, BMW of North America, LLC will reimburse qualifying customer pay repairs that were performed on affected vehicles up to 10 days after the date the  
 Copyright ©2025 MOTORRAD USA, a division of BMW of North America, LLC. All Rights Reserved

owner notification letter was sent out by BMW.

If the customer previously paid for a qualifying repair, verify in AIR that the VIN is affected by the recall campaign and proceed as applicable:

#### **The customer arrives with an affected vehicle to your workshop**

- Perform the open Recall repair outlined in this bulletin, regardless of previous repair history.
- If the prior repair qualifies (see below), submit for both the Recall repair and the customer-pay reimbursement (Separate repair line items/separate defect codes).

Or:

#### **The customer only presents your center with a customer-pay invoice for the prior repair**

- If the vehicle and the prior repair qualifies (see below), submit for the customer-pay reimbursement portion only.

#### **Customer-pay Invoice Review and Reimbursement Qualification and Procedure**

Review and verify that the prior customer-pay invoice (BMW center or independent repair shop) contains a repair that pertains to the recall campaign. Only the repair outlined in the published safety recall service bulletin is eligible for reimbursement.

If this prior repair qualifies, submit a claim for reimbursement:

- Verify in AIR that the VIN was affected by the recall campaign.
- Use defect code 85 99 00 45 NA for the amount requested under sublet 03.
- Comment: (61 09 24 Recall 24V-716 - Deactivating reverser control unit) - Reimbursement for allowable expenses that relate to performing the prior qualifying customer-pay repair.
- Use current repair date and mileage for claim submission.
- Retain copies of the customer paid invoice and the current repair invoice in your records.
- Reimburse the customer directly (parts and labor).

Contact warranty via an IDS ticket with any questions.

Retain the original customer pay invoice in your files; this documentation may be requested by BMW during the claim review process.

**Note:** A repair performed on a non-affected vehicle, or the diagnosis and repair of other unrelated issues do not qualify for reimbursement.

This claim submission for the prior customer-pay reimbursement, when it is submitted as outlined under Defect Code 85 99 00 45 NA, **will not close** the Open Safety Recall on the vehicle.

## **QUESTIONS REGARDING THIS BULLETIN**

Technical inquiries	Contact the BMW Technical Support Group via TSARA
Warranty inquiries	Submit an IDS ticket to the Warranty Department
Parts inquiries	Submit an IDS ticket to the Motorrad Parts Department

#### Supporting Materials

[picture\\_as\\_pdf 61 03 25 Combined.pdf](#)

[picture\\_as\\_pdf RM\\_0060447\\_0L11\\_EN.pdf](#)

[picture\\_as\\_pdf 61 03 25 Recall 24V-716 - R 18 Reverser.pdf](#)

[picture\\_as\\_pdf How to Use YOCV Campaign Order.pdf](#)



**OL11 - R 18****00 60 447 Installing additional wiring harness with relay****NOTICE**

If the reverser has already been deactivated, the cable from the auxiliary reversing engine to the control unit must be installed.

If the reverser has already been deactivated, a ground cable must be installed between the transmission housing and the control unit.

Additional work: 46 52 510 Mounting and dismantling the rear-wheel stand with special tools (for motorbikes without a centre stand)

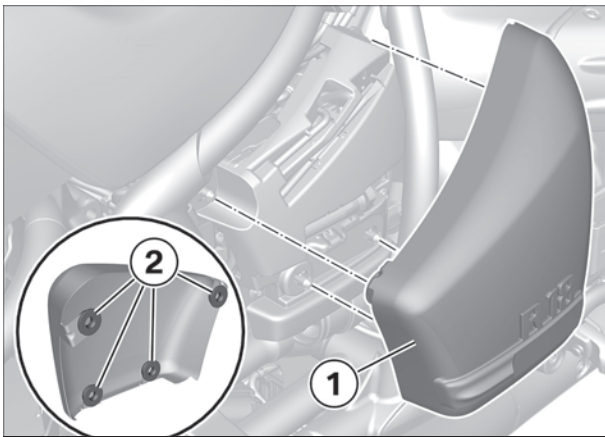
**1****► Removing right side cover**

- Pull off side cover **(1)** with rubber grommets **(2)** and remove.

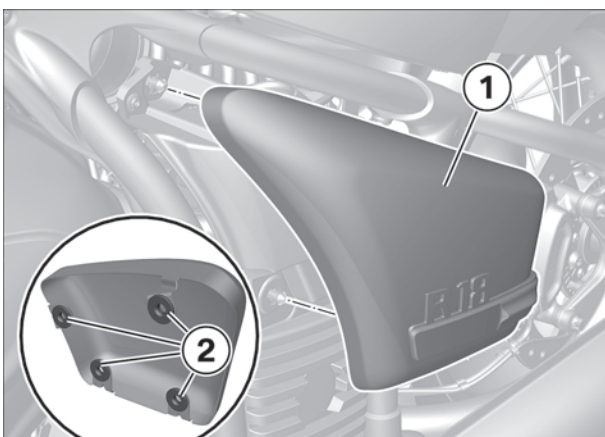
**2****► Removing left side cap**

- Pull off side cover **(1)** with rubber grommets **(2)** and remove.

3

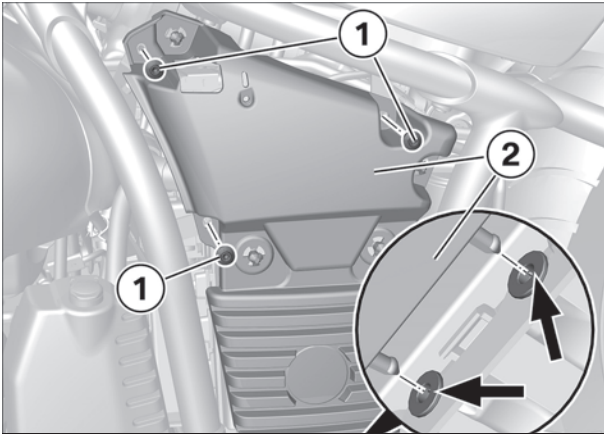

► **Remove support for left side cover**

- Remove screws (1).
- Detach support (2) at bottom (Arrows) and remove.

4

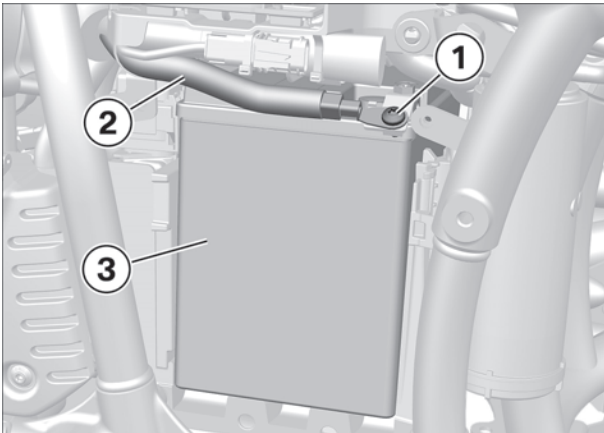

► **Disconnect battery from vehicle**

**Requirement**

Ignition is switched OFF.

- Remove screw (1) and loosen negative wire (2) from battery (3).
- Insulate negative wire (2) with adhesive tape or similar.

5

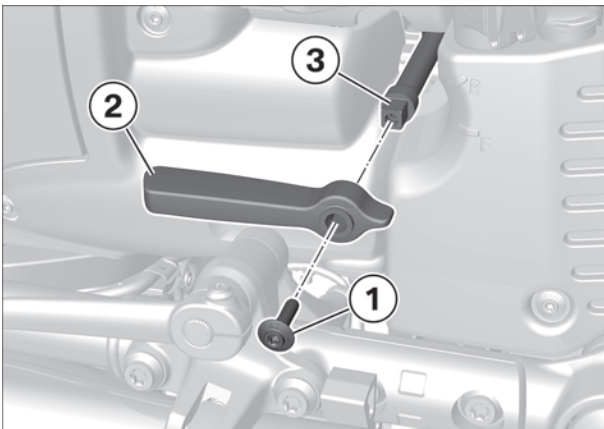

► **Removing gearshift lever for reverser**

- Remove screw (1).
- Pull gearshift lever (2) off shaft (3).

6

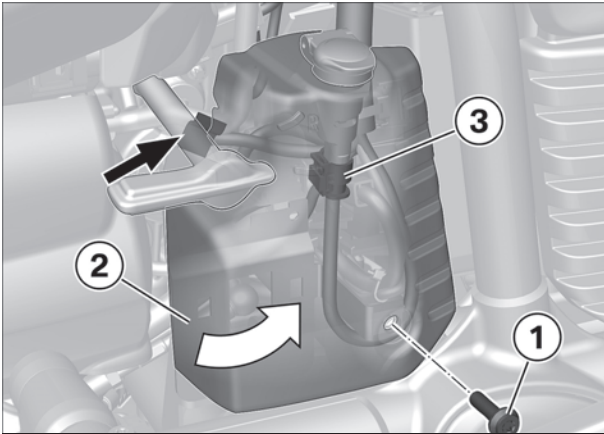

► **Removing trim for Keyless Ride control unit**

- Remove screw (1).
- Pivot trim (2) upwards and detach from holder (arrow).
- Disconnect connector (3).

7

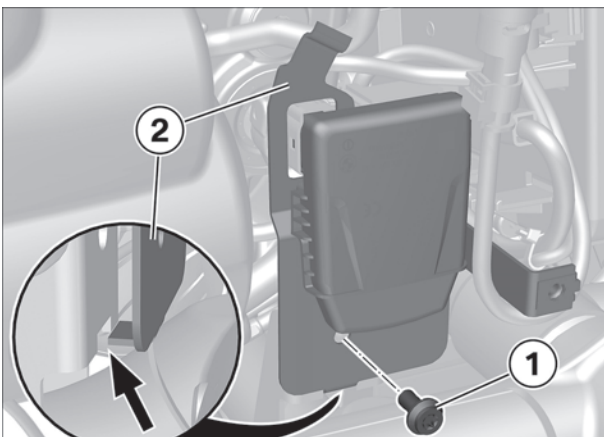

► **Keyless Ride Removing the control unit with holder**

- Remove bolt (1).
- Disengage holder (2) from hook (Arrow) and work clear.

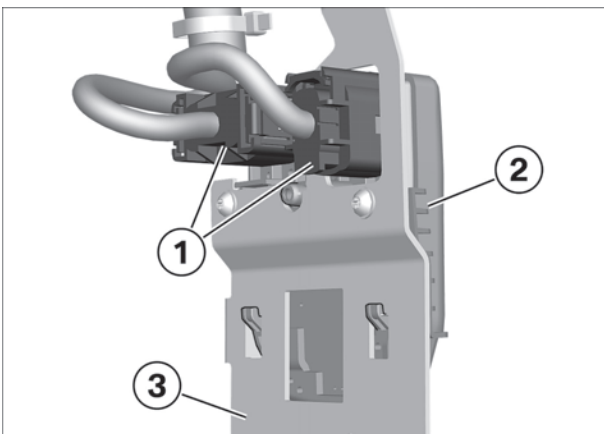

- Disconnect connector (1).
- Remove control unit (2) with holder (3).

## 8

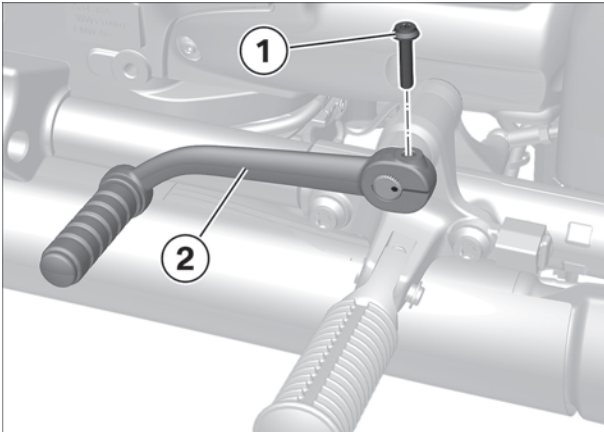
► **Removing gearshift lever**

- Remove bolt (1).
- Remove gearshift lever (2).

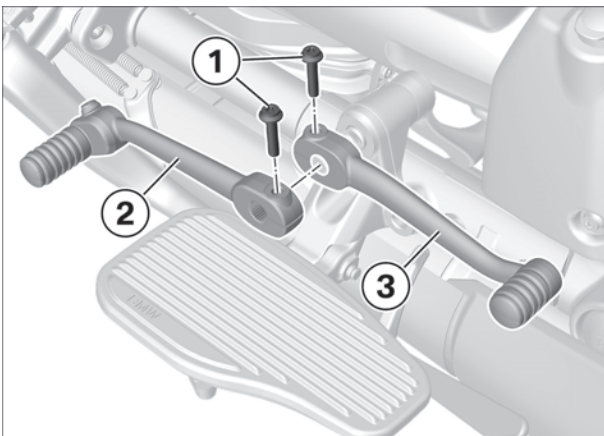

– with footboard<sup>OE</sup> (036A)

- Remove screws (1).
- Remove gearshift lever (2) and (3).◇

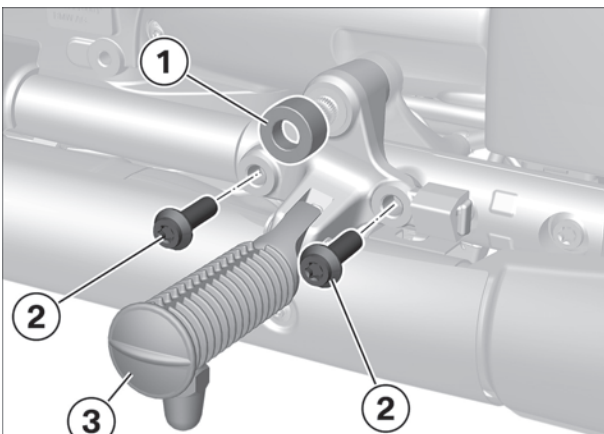

## 9

► **Removing front left footrest plate**

- Extend the side stand.
- Remove spacer sleeve (1).
- Remove screws (2).
- Remove the footrest plate (3).

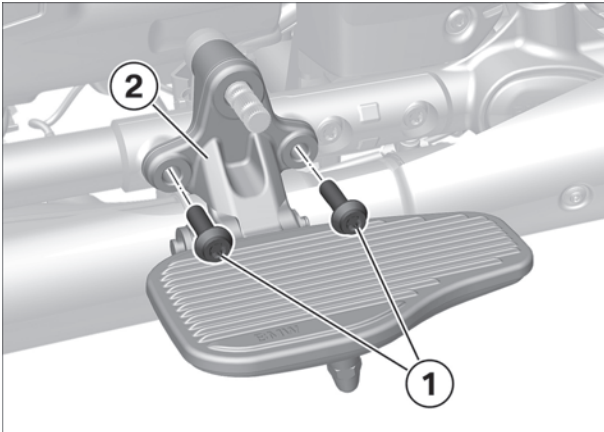

- with footboard<sup>OE</sup> (036A)
- Extend the side stand.
- Remove screws **(1)**.
- Remove the footrest plate **(2)**.◇

## 10

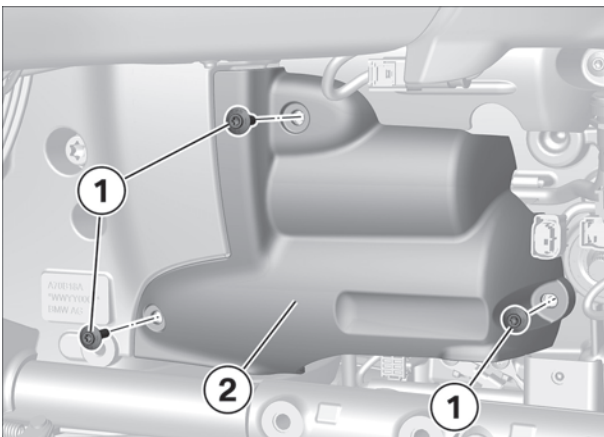

### ► Removing cover for starter motor

- Remove screws **(1)**.
- Remove cover **(2)**.

## 11

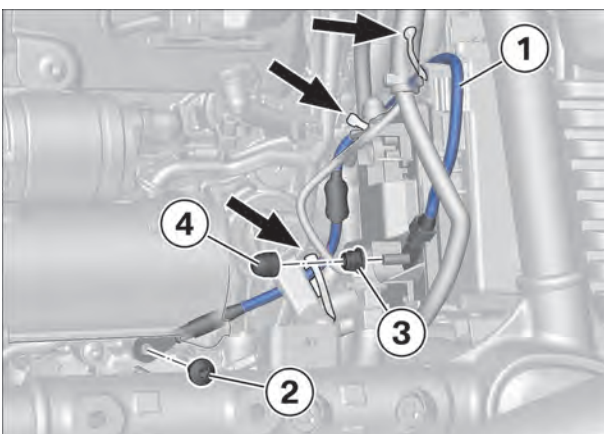

### ► Installing ground cable from transmission housing to reverser (if reverser was deactivated)

- Route ground cable **(1)** in the vehicle.
- **Short cable section points towards transmission.**
- Secure ground cable with screw **(2)** and nut **(3)**.

Tightening torques		
Wiring harness (ground) to transmission		
M6 x 12 - 10.9	8 Nm	
Wiring harness to reverser control unit		
M6	5 Nm	

- Install cable strap **(arrow)**.
- Ensure **sufficient distance to gearshift lever!**
- Install protective cap **(4)**.

# 12

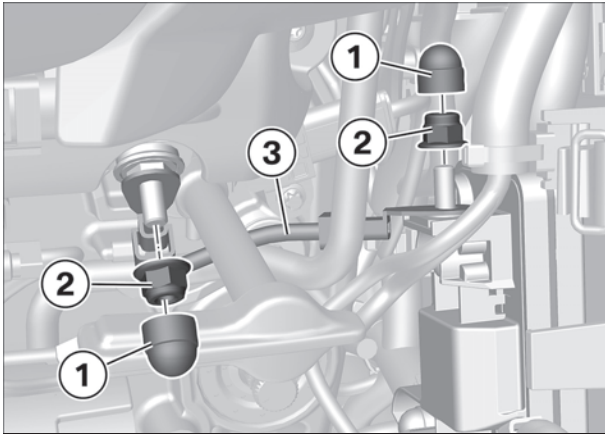

► **Installing cable from auxiliary reversing engine to control unit (if reverser has been deactivated)**

- Install cable (3).
- Install nuts (2) and protective caps (1).

🔧 Tightening torques		
<b>Wiring harness to reverser control unit</b>		
M6	5 Nm	
<b>Cable terminal on engine for reverser</b>		
M6	8 Nm	

# 13

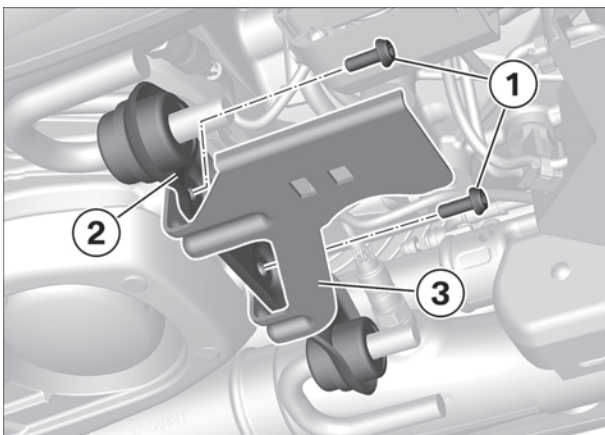

► **Securing relay holder on oil sump**

- Remove screws (1) and push manifold holder (2) slightly to the rear.
- Insert relay holder (3) under the manifold holder.
- Install screws (1).

🔧 Tightening torques		
<b>Manifold bracket to oil sump</b>		
M6 x 18	8 Nm	

– Install longer screw M6 x 18.

# 14

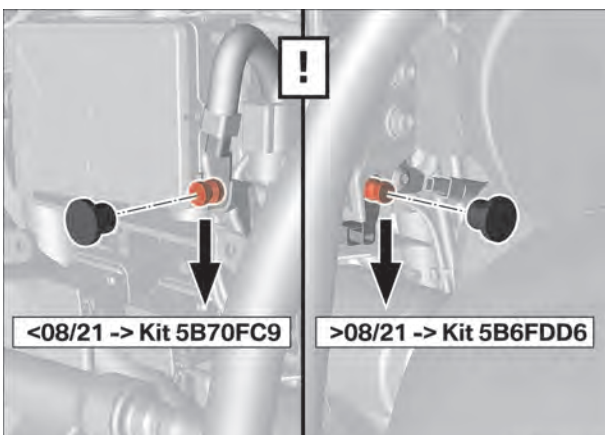

► **Selecting additional wiring harness according to build level**

- Vehicles before 08/2021:
  - Jump start connection under side cover
  - Additional wiring harness 5B70FC9
- Vehicles after 08/2021:
  - Jump start connection on side at front
  - Additional wiring harness 5B6FDD6

## 15

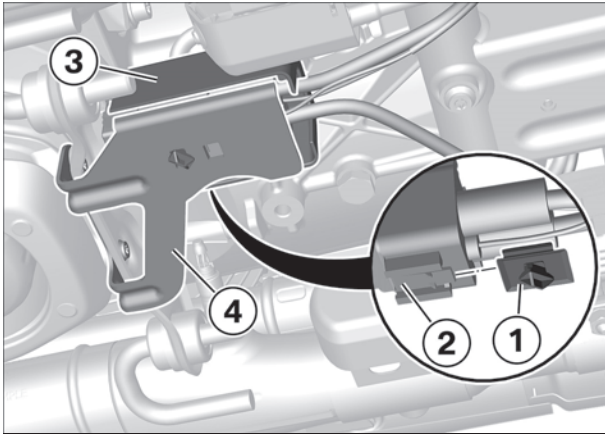

## ► Installing retrofit wiring harness with relay

- Secure add-on element (1) on relay (2).
- Secure protective cap (3) on relay (2).
- Secure relay (2) on relay holder (4).

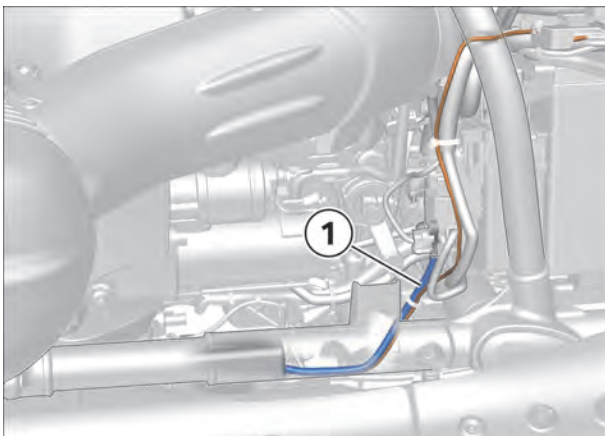

- Install retrofit wiring harness (1).
- Ensure **sufficient distance to gearshift lever!**

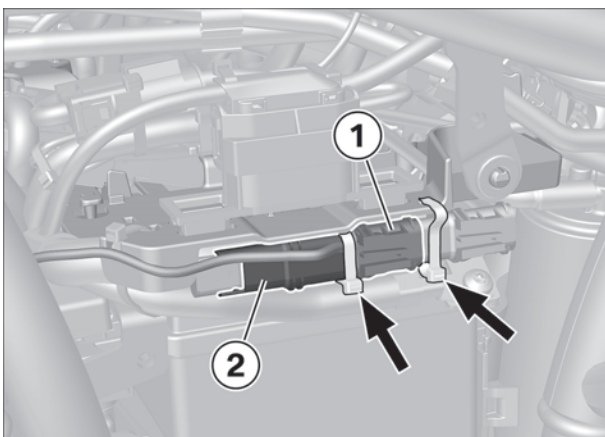

- Disconnect optional accessories connector (1).
- Connect retrofit wiring harness (2) with connector (1) and vehicle wiring harness.
- If necessary, reconnect optional accessories or install blind cap.
- Secure cables and connectors (**arrows**).

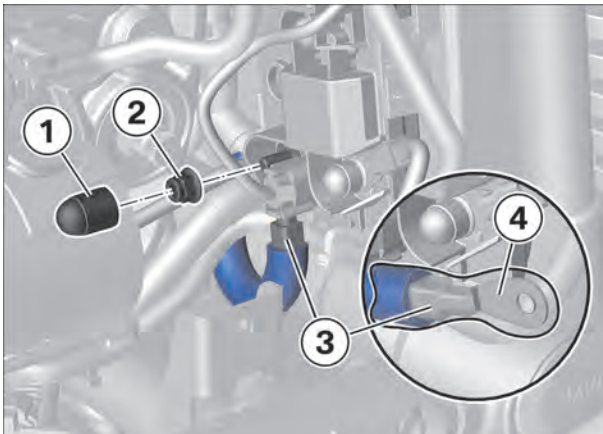

- Remove protective cap **(1)** and nut **(2)**.
- Loosen cable **(3)** and place to the outside.

**ATTENTION**

**Component damage**

Components are damaged by heat.

- Only shrink heat-shrink tubing at approx. 100°C.
- Use an adjustable hot air blower.
- Monitor the temperature in the working area; cover adjacent components.

- Insulate cable **(3)** with heat-shrink tubing **(4)**.
  - Push heat-shrink tubing on as far as possible and shrink with **max. 100°C**.
- Secure insulated cable **(3)** with cable strap later.
- Secure **retrofit wiring harness** with nut **(2)** on control unit.

Tightening torques		
Wiring harness to reverser control unit		
M6	5 Nm	

- Install protective cap **(1)**.
- Install cable strap **(arrow)**.
  - Ensure **sufficient distance to gearshift lever!**
- Secure retrofit wiring harness **(1)** with cable strap **(arrows)**.
  - Ensure **sufficient distance to gearshift lever!**

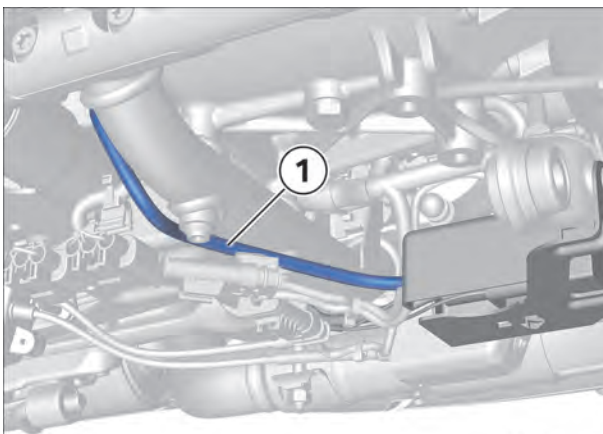
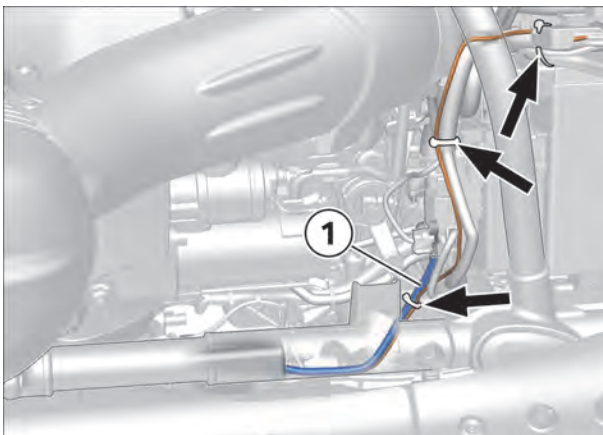

- Route retrofit wiring harness **(1)** from relay to jump start connection.
  - Route cable according to graphic.

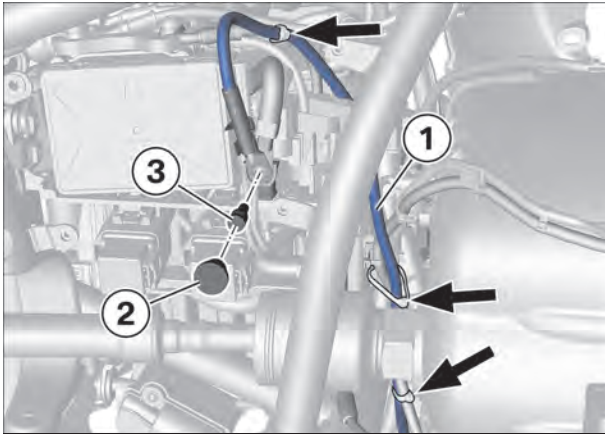

- Routing on vehicles before 08/2021:
  - Jump start connection under side cover
  - Additional wiring harness 5B70FC9
- Route retrofit wiring harness (cable B+) (1) to jump start connection.
  - Route cable according to graphic.
- Remove protective cap (2) and screw (3).
- Secure **cable B+ and original cable** with screw (3).
- Install protective cap (2).
- Install cable strap (arrows).
- Ensure **sufficient distance to propeller shaft/nut!**

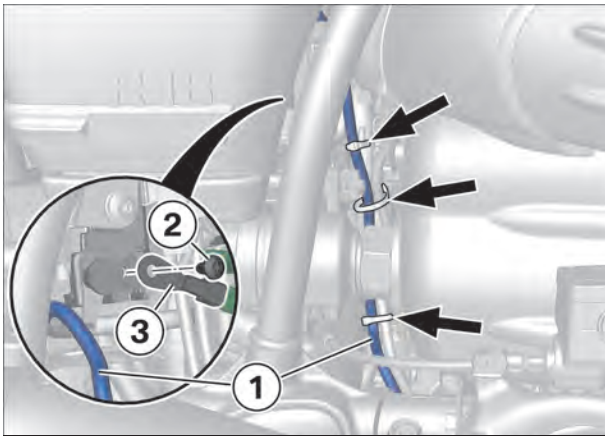

- Routing on vehicles after 08/2021:
  - Jump start connection on side at front
  - Additional wiring harness 5B6FDD6
- Route retrofit wiring harness (cable B+) (1) to jump start connection.
  - Route cable according to graphic.
- Remove screw (2).
- Secure **cable B+ and original cable** (3) with screw (2).
- Install cable strap (arrows).
- Ensure **sufficient distance to propeller shaft/nut!**

## 16

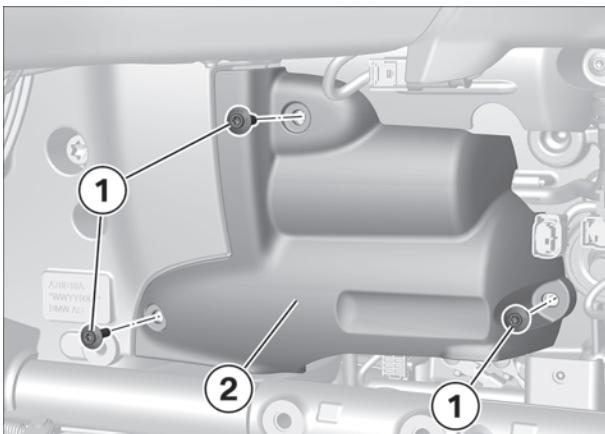

- ▶ **Installing cover for starter motor**
  - Insert cover (2) and install screws (1).
  - 6 mm bolts with collar

17

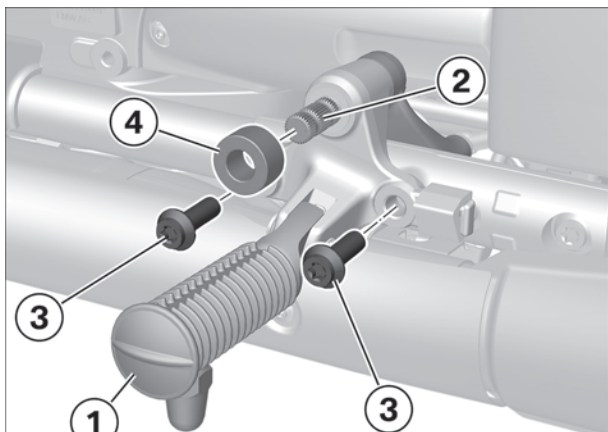

► Installing front left footrest plate

- Clean thread.

**ATTENTION**

**Damage of the bearing due to lubricants.**

Component damage, stiff movement

- Lubricants can damage the coating chemically.
- Lubricant bind dirt particles and increase the wear by this.
- A PTFE-bearing is maintenance free; do not lubricate the bearing.

- Attach footrest plate (1) on gearshift shaft (2).
- Install screws (3).

Tightening torques		
Footrest plate to frame bottom truss		
M10 x 30 - 10.9, Replace screw or use screw lock Thread-locking compound (micro-encapsulated), Thread-locking compound (Loctite 243, Medium strength)	56 Nm	

- Clean and install spacer sleeve (4).

– with footboard<sup>OE</sup> (036A)

- Clean thread.

**ATTENTION**

**Damage of the bearing due to lubricants.**

Component damage, stiff movement

- Lubricants can damage the coating chemically.
- Lubricant bind dirt particles and increase the wear by this.
- A PTFE-bearing is maintenance free; do not lubricate the bearing.

- Attach footrest plate (1) on gearshift shaft (2).
- Install screws (3).

Tightening torques		
Footrest plate to frame bottom truss		
M10 x 30 - 10.9, Replace screw or use screw lock Thread-locking compound (micro-encapsulated), Thread-locking compound (Loctite 243, Medium strength)	56 Nm	

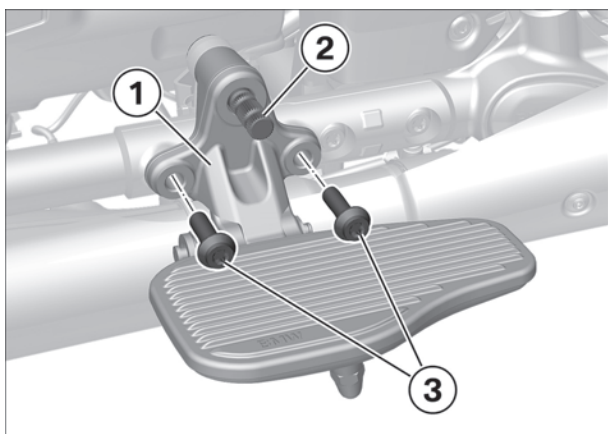

18

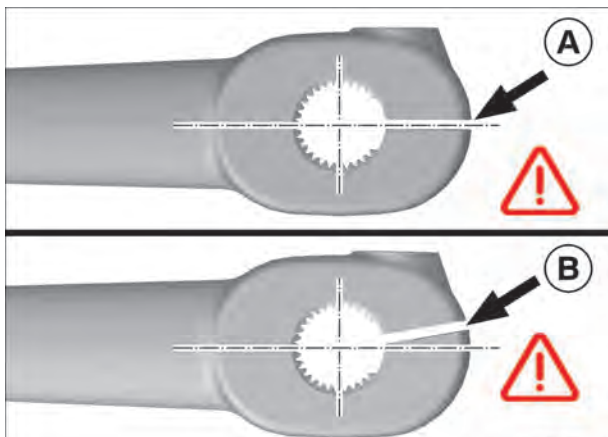

► **Installing gearshift lever**

- with footboard<sup>OE</sup> (036A)
- Check build level of **outside** gearshift lever:
  - Build level A, groove in line: install gearshift lever offset to the bottom by one tooth.
  - Build level A, groove offset: install groove (gearshift lever) aligned with punch mark (shaft).◇

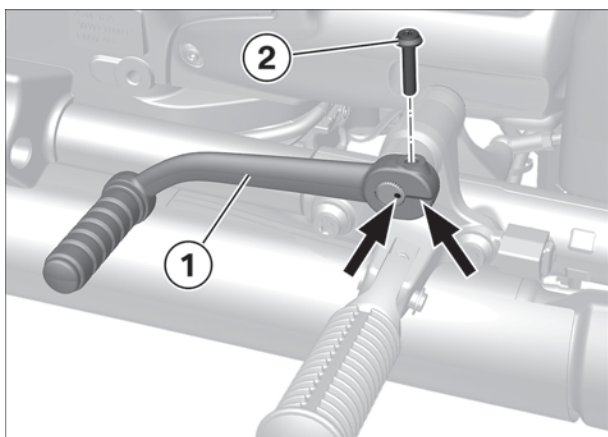

- Position gearshift lever **(1)** aligning punch mark on groove (**arrows**).
- Install screw **(2)**.

 <b>Tightening torques</b>		
<b>Gearshift lever to selector shaft</b>		
M6 x 25	8 Nm	

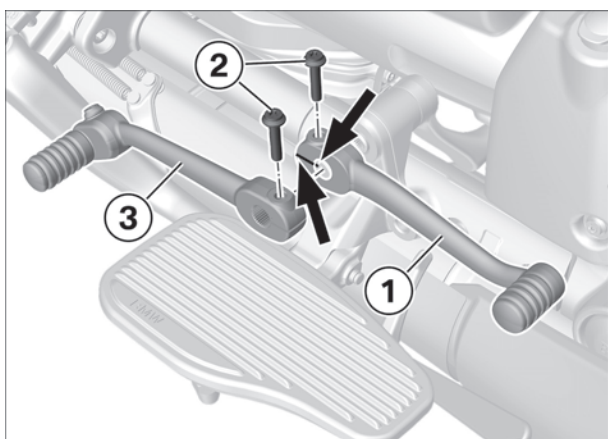

- with footboard<sup>OE</sup> (036A)
- Position inner gearshift lever **(1)** aligning punch mark on groove (**arrows**).
- **Build level A:** Attach gearshift lever outside **(3)** aligning groove **with one tooth offset to the bottom** with punch mark on shaft.
  - » Clearance of gearshift lever outside when downshifting is ensured.
- **Build level B:** Position **outer** gearshift lever **(3)** aligning **groove on punch mark**.
- Install screw **(2)**.

 <b>Tightening torques</b>		
<b>Gearshift lever to selector shaft</b>		
M6 x 25	8 Nm	

## 19

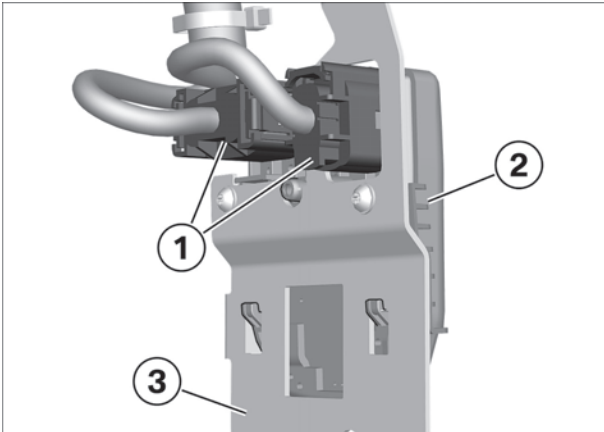

► **Keyless Ride Installing the control unit with holder**

- Connect connector (1) to control unit (2) and holder (3).

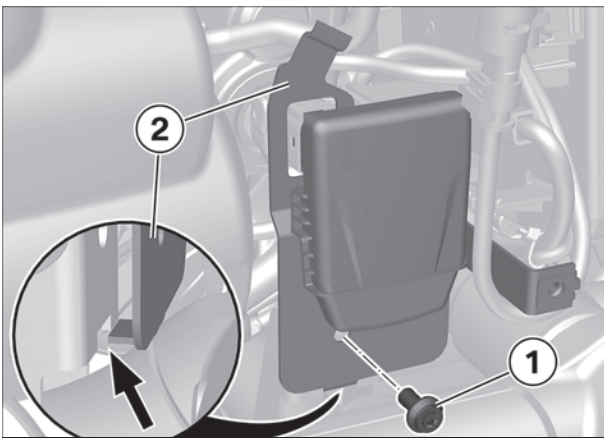

- Insert holder (2) and secure in hook (arrow).
- Install bolt (1).

## 20

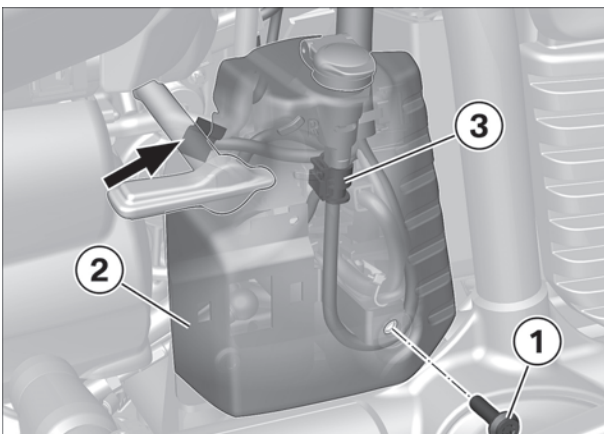

► **Installing trim for Keyless Ride control unit**

- Connect connector (3).
- Engage trim (2) in holder (arrow) and pivot down.
- Install screw (1).

# 21

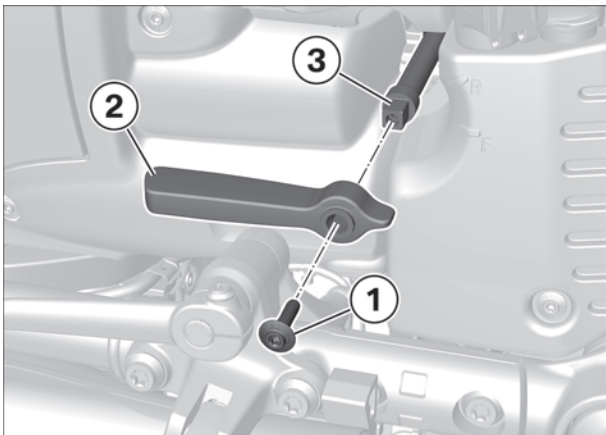

### ► Installing gearshift lever for reverser

- Push gearshift lever **(1)** onto shaft **(2)**. In doing so, pay attention to mounting orientation **(arrows)**.
  - Lug points to the rear.
  - Note shaft square.
- Install screw **(3)**.

Tightening torques		
Gearshift lever to gearshift shaft reverser		
M5 x 20 Thread-locking compound (micro-encapsulated)	8 Nm	– with reverser <sup>OE</sup> (05AA)

# 22

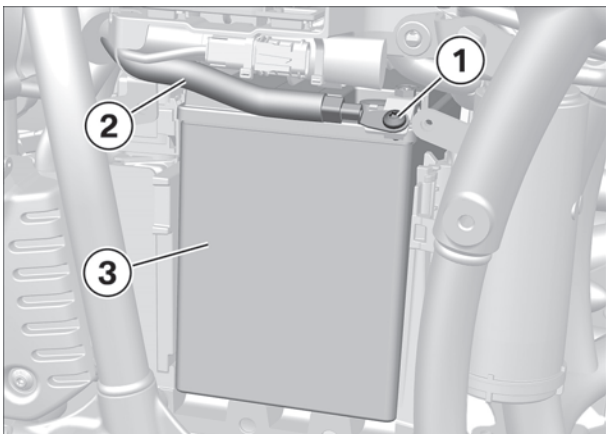

### ► Connect battery with vehicle

- Remove insulation from negative wire **(2)**.
- Secure positive wire **(2)** on battery **(3)** with screw **(1)**.

# 23

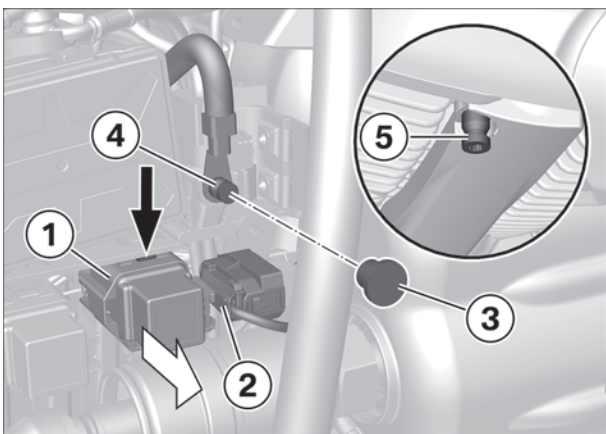

### ► Connect BMW Motorrad diagnosis system on vehicle

- Push locking bar **(arrow)** down and pull relay holder **(1)** to front.
- Loosen analysis connector **(2)**.
- Remove cap **(3)**.
- Connect BMW Motorrad battery charger on jump start terminal point **positive terminal (4)** and **negative terminal (5)**.

### NOTICE

For diagnosis and programming, use a battery charger with 30 A approved by BMW Motorrad that ensures a vehicle electrical system voltage of 13 V.

**Workshop equipment**

Order No.: 81 39 5 A08 1B7

Deutronic Smart Charger Lithium 35

- Connect connecting cable of BMW Motorrad diagnosis system with diagnostic socket **(2)**.

**NOTICE**

See the information about the BMW diagnostic system for all further instructions.

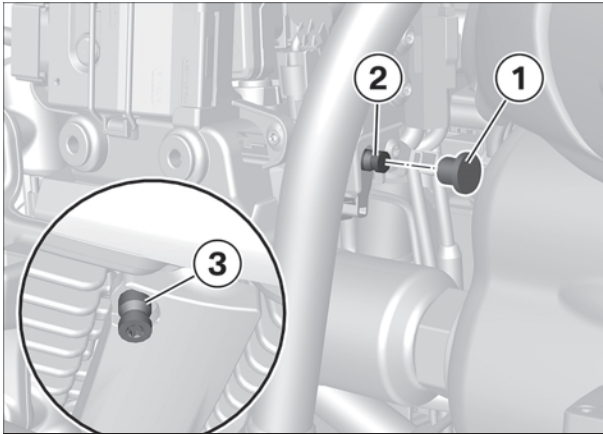

– As of build level August 2021<sup>CST</sup>

- **On right side of vehicle:** Remove cap **(1)**.
- Connect BMW Motorrad battery charger on jump start terminal point **positive terminal (2)** and **negative terminal (3)**.

**NOTICE**

For diagnosis and programming, use a battery charger with 30 A approved by BMW Motorrad that ensures a **vehicle electrical system voltage of 13 V**.

**Workshop equipment**

Order No.: 81 39 5 A08 1B7

Deutronic Smart Charger Lithium 35◇

– As of build level August 2021<sup>CST</sup>

- **On left side of vehicle:** Loosen analysis connector **(1)**.
- Connect connecting cable of BMW Motorrad diagnosis system with diagnostic socket **(1)**.

**NOTICE**

See the information about the BMW diagnostic system for all further instructions.◇

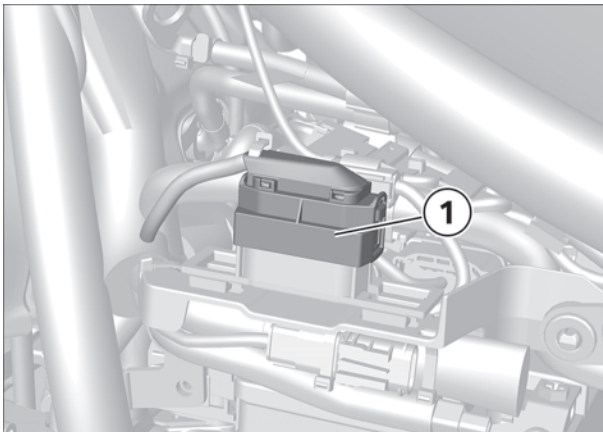
▶ **Programming vehicle control unit**

- Start programming and follow the instructions of the BMW Motorrad diagnosis system.

## 25

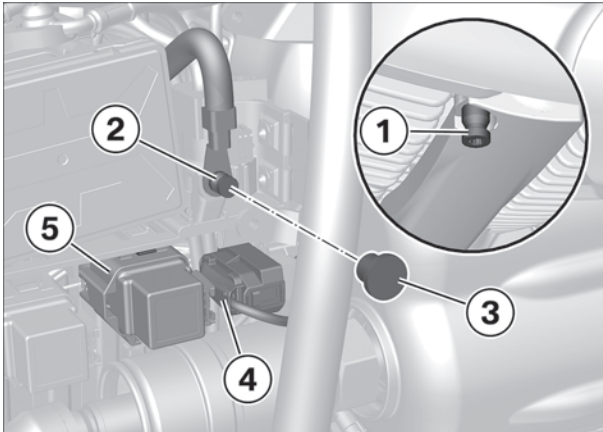

► **Disconnect BMW Motorrad diagnosis system from vehicle**

- Close all diagnostic programs and switch off the ignition.
- Loosen BMW Motorrad battery charger from jump start terminal point **negative terminal (1)** and **positive terminal (2)**.
- Install cap **(3)**.
- Disconnect connecting cable of BMW Motorrad diagnosis system from diagnostic socket **(4)**.
- Secure analysis connector **(4)**.
- Secure relay holder **(5)**.

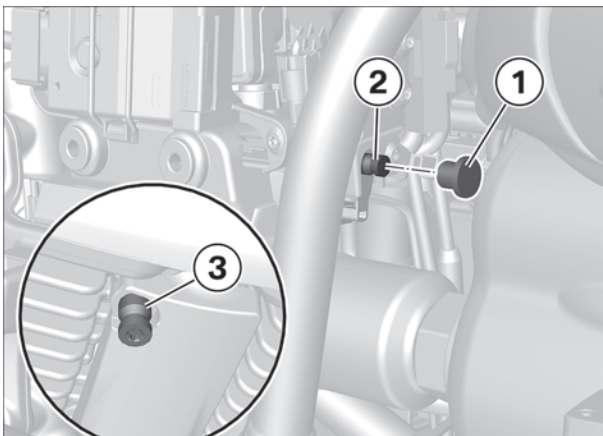

– As of build level August 2021<sup>CST</sup>

- Close all diagnostic programs and switch off the ignition.
- Loosen BMW Motorrad battery charger from jump start terminal point **negative terminal (3)** and **positive terminal (2)**.
- Install cap **(1)**.◇

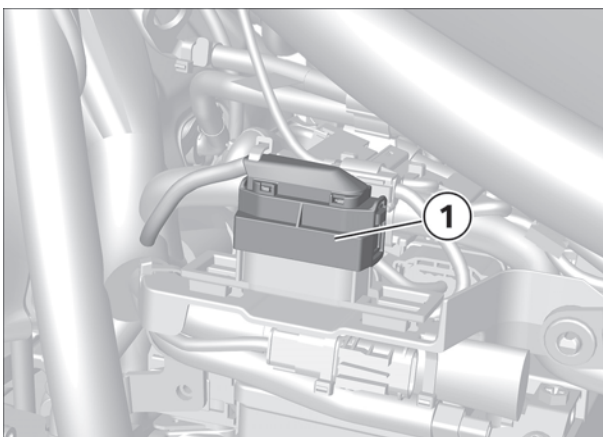

– As of build level August 2021<sup>CST</sup>

- Disconnect connecting cable of BMW Motorrad diagnosis system from diagnostic socket **(1)**.
- Secure analysis connector **(1)**.◇

# 26

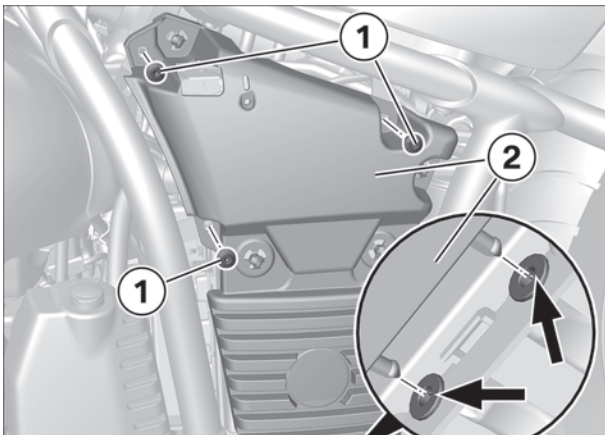

► **Install support for left side cover**

- Clean the threads.
- Position support (2) and secure at bottom (arrows).
- Install screws (1).

 <b>Tightening torques</b>	
<b>Support for side cover to frame</b>	
M5 x 14, Renew screw Thread-locking compound (micro-encapsulated)	2 Nm

# 27

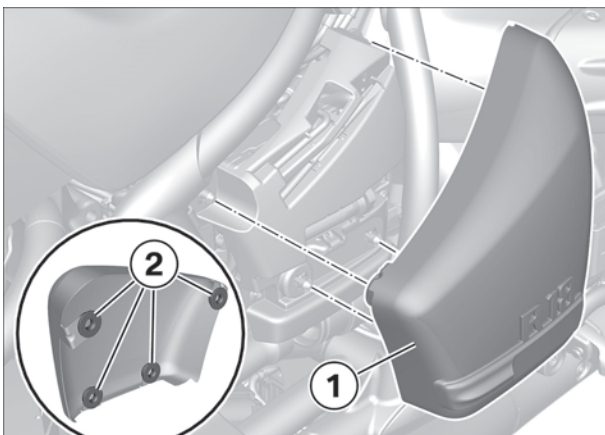

► **Installing right side cover**

- Lubricate rubber grommets (2) lightly.

 <b>Care products</b>	
Rubber care product	83 12 0 397 018

- Position side cover (1) and secure with rubber grommets (2).
  - First insert at the bottom, then press on the top.
  - Check side cover for tight fit, it must be secured in all 4 rubber grommets.

# 28

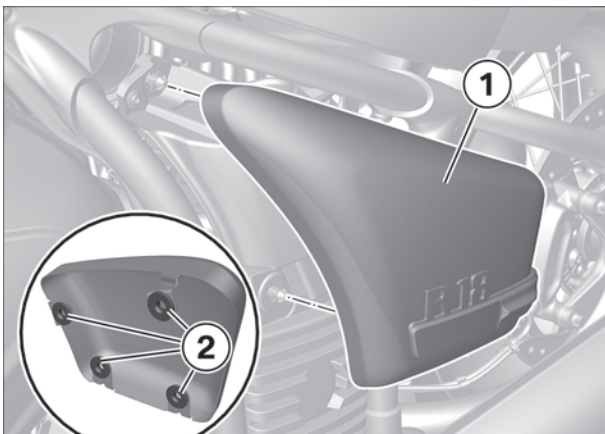

► **Installing left side cap**

- Lubricate rubber grommets (2) lightly.

 <b>Care products</b>	
Rubber care product	83 12 0 397 018

- Position side cover (1) and secure with rubber grommets (2).
  - First insert at the bottom, then press on the top.
  - Check side cover for tight fit, it must be secured in all 4 rubber grommets.

► **Final inspection of completed work**

- Ensure the following:
  - The objective of the completed work was achieved.
  - All operating fluids have been filled in and the fluids are at the correct fill level.
  - All loosened screw connections have been retightened correctly.
  - The fuel system is free of leaks.
  - The lighting and signal system is functional and the vehicle is roadworthy.
  - The brake pads of the front and rear wheel brakes are resting against the brake disks.

▷ **Function test, engine start suppression**

**Check**

- Select neutral.
  - » Neutral indicator light "N" lights up.
- Select a gear.
  - » Neutral indicator light "N" goes out.
- Press the starter button.
  - » Starter does **not** operate.
- Extend the side stand.
  - » Starter does **not** operate.
- Pull the clutch lever.
  - » Starter does **not** operate.
- Press the starter button.
  - » Starter does **not** operate.
- Retract the side stand.
  - » Starter does **not** operate.
- Press the starter button without releasing the clutch lever.
  - » Starter operates.

**Result**

Not all test steps completed successfully.

**Measure**

- Check corresponding components with BMW Motorrad diagnosis system.



## How To Use the YOCV Campaign Order Type

### Step 1: Access to YOCV Order Type in DCS.

Menu [ 48778 ] CenterNet Sitemap Help Feedback Logout  
DC Snet Administration Sales Service Parts Corporate

### Parts Order Details

Order Summary

Dir Order Nbr:  Order Type: **YOCV Campaign** Save  
Status: Incomplete Campaign Number:  VIN:  Ship To: 04 - 9750 Regency Square  
YOCV Late Day Rush  
YOR Stock  
YVOR Rush

Back To List Send Print Credit Check

### Step 2: Enter the Correct Campaign Number, Full VIN & Click Send.

DC Snet Administration Sales Service Parts Corporate

### Parts Order Details

Order Summary

Dir Order Nbr: 05191778 Order Type: YOCV Campaign Save  
Status: Incomplete Campaign Number: 3102224141 VIN: L123456 Ship To: 01 - 20 COLONY RD

Order Details

ATL	Part Number	Part Description	Qty	Alloc	Comment	Bin Location	Ref	Unit Price USD	Ext Price USD	SRC
No items found										

0 selected items Total Qty: 0 Total Ext Price: 0.00  
Select All | Clear All Locate Save & Recalculate Delete  
Back To List Send Print Credit Check

**Campaign Number:  
USE CORRECT CAMPAIGN  
FROM ABOVE TABLE**

**ENTER THE FULL VIN**

**Step 3: This method of ordering:**

- Does not immediately show the parts on order through that “Campaign Number” and VIN combination.
- Will only accept orders with a valid combo of Campaign Number and VIN that hasn’t already been used.

### Parts Order Send Confirmation

Dir Order Nbr	Order Type	Order Status	Comments
<u>020718AK</u>	YOCV Campaign	Sent To BMW	Campaign Order VIN 3482763646 has been saved (delivery 9314584157 created)

Back To List
Print

- Clicking on Order allows you to see parts on order after order is successfully sent

### Parts Order Details ? [Help](#)

**Order Summary**

Dir Order Nbr:	012621	Order Type:	YOCV Campaign	Billing Block:	Delivery Block:
Status:	Sent To BMW	Campaign Number:	3103351579	VIN:	WB10M1301M6D60614
Order Date:	01/26/2021	Order Time:	11:07	Ship To:	01 - 875 Middlesex Ave

**Order Details**

ATL	Part Number	Part Description	Qty	Alloc	Comment	Bin Location	Ref	Unit Price USD	Ext Price USD	SRC	
1	<input type="checkbox"/> 34 11 8 535 158	<input type="checkbox"/> Set of mounting parts,	2	2					22.66	45.32	D320
2	<input type="checkbox"/> 34 11 8 548 028	<input type="checkbox"/> Set of brake pads fron	2	2					61.39	122.78	D320
3	<input type="checkbox"/> 34 11 8 556 254	<input type="checkbox"/> CALIPER RIGHT	1	1					485.04	485.04	D320
4	<input type="checkbox"/> 34 11 8 556 253	<input type="checkbox"/> Brake caliper, left	1	1					485.04	485.04	D320