



SIB 61 09 24 RECALL 24V-716: Disable Reverser

2025-01-24

This Service Information Bulletin replaces SIB 61 09 24 **posted Sept 27, 2024.**

What's New (Specific text highlighted):

- Customer Compensation Section: Final repair date added for compensation.

MODEL

Model	Model Description	Model Code
K34	R 18	0L13
K34	R 18 Classic	0L23
K34	R 18 Roctane	0N63
K35	R 18 Bagger	0L33
K35	R 18 Transcontinental	0L43

The affected vehicles have been marked with campaign number **0000611900** in AIR.

In order to determine if a specific motorcycle is affected by this campaign, it will be necessary to verify the vehicle VIN in AIR (Aftersales Information Research). Based on the response of the system, either proceed with the repair or take no further action. Please note, open campaigns or vehicle stops may not appear in DCS Warranty Vehicle Inquiry or sales systems until 24-72 hours after they are announced, therefore AIR is always the recommended method for determining open campaigns and vehicle stops.

SITUATION

After quality inspection, BMW Motorrad has found that due to insufficient sealing of the reverser control unit, moisture can leak into the control unit. This can lead to corrosion of electrical contacts inside the control unit over time and under certain warm-humid (all year round) climatic conditions. This corrosion can result in a failure of the reverser function.

In rare cases, high resistance creating high amperage can occur between the corroded contacts, resulting in overheating of the components that could develop into thermal damage to the control unit.

The affected vehicles have been placed under the delivery stop **STOP610019** associated with campaign number 0000611900, which will be lifted upon completion of this technical campaign.

PROCEDURE

For vehicles that have not been delivered, the Recall must be carried out before delivery to customers and during the retail process the disclosure letter (attached below) must be signed by the customer and dealer representative. Two copies must be made with one provided to the customer at the time of retail and the other to be placed in the vehicle file.

For vehicles already retailed, Customer recall letters are being mailed to owners via First Class mail advising them of this recall and asking them to schedule an appointment with an authorized BMW Motorrad dealer to have the recall procedure performed. The customer must be made aware the reverser function is disabled and the disclosure letter (attached below) must be signed by the customer and dealer representative.

As an interim repair measure to prevent thermal damage, the reverser control unit must be disabled in accordance with AIR repair instructions "00 60 437 – Permanently disconnecting reverser control unit from wiring harness".

NOTE: The removed cables must be destroyed, then scrapped and must not be returned to the customer.

Customer Disclosure Letter

Attached below is a customer disclosure letter.

For new customers at time of sale of the motorcycle with reverser disabled:

- The disclosure must be reviewed and signed by the customer and dealer representative.
- A copy must be made and provided to the purchasing customer.

- The original should be filed in the dealer's vehicle file.

For current customers having the reverser disabled:

- The disclosure must be reviewed and signed by the customer and dealer representative during the service visit.
- A copy must be made and provided to the customer when picking up the motorcycle.
- The original should be filed in the dealer's vehicle file.

Customer Compensation for New and Used Vehicle Customers:

UPDATE: Compensation will not be permissible for units repaired with a repair date after 01/31/2025.

As compensation for the temporary loss of use of the reverser feature, you can offer the customer up to \$1,000 (parts cost plus handling) in genuine BMW Motorrad accessories for R 18 models. Claim information is listed below.

This compensation offer applies until the improved reverser control unit is available for replacement and the final repair bulletin is published.

The offer applies only to retailed units.

To claim for this compensation, the unit must have been RDR'd. The compensation does not apply to new or used unsold vehicle inventories.

NOTE: This is **not** a sales incentive. It is compensation to a customer for the temporary loss of a feature.

NHTSA STATEMENT

Please be reminded that it is a violation of federal law (The Safety Act) for you to sell, lease or deliver any new motorcycle covered by this notification until the recall repair has been performed. This means that dealers may not legally deliver new motorcycles to consumers until they are fixed or use/sell replacement equipment/parts subject to this recall. Note also that substantial civil penalties apply to violations of the Safety Act. Also, you should not sell, lease or deliver any used motorcycles subject to a safety recall until the repair is completed. Please follow any special instructions that we provide to you for the return or disposition of recall parts.

PARTS INFORMATION

Obtain and confirm the part numbers for your specific vehicle by entering the chassis number in ETK which takes into account specific equipment and/or options.

Additional parts like gaskets, hardware and chemicals may be required for the complete repair.

Copyright ©2025 MOTORRAD USA, a division of BMW of North America, LLC. All Rights Reserved

Part Number

07 12 9 908 527	Cheese head screw (If necessary, see repair instruction)	QTY 2
-----------------	--	-------

CLAIM INFORMATION

Please submit claims via the normal claim process using the information below:

Defect Code

00 00 61 19 00	Disabling Reverser Control Unit
----------------	---------------------------------

Labor Operation

00 60 437	Disconnect control unit for reverser from the wiring harness	6 FRU
+00 60 937	Disconnect control unit for reverser from the wiring harness	5 FRU

FRUs includes all repair procedures to complete the task with allowance for necessary ancillary tasks (e.g., visual inspection, lubrication, cleaning parts etc.) and administrative tasks.

Labor operation code 00 60 437 is a Main labor operation. If you are using a Main labor code for another repair, use the Plus code labor operation instead.

Customer Compensation Claim and Parts Information**Defect Code**

77 99 90 01 00	Customer Compensation for Recall Campaign 00 00 61 19 00
----------------	--

Part Number

77 XX X XXX XXX	Genuine BMW Motorrad Accessories for R 18 Models
-----------------	--

NOTICE: The permissible maximum compensation is \$1,000 (including parts cost plus handling) as a one-time settlement that applies only for genuine BMW Motorrad accessories for R 18 models.

In cases where the accessory/s that the customer wants exceeds the maximum \$1,000 (including parts cost plus handling) amount, the customer must pay the difference between the accessories cost and the max contribution amount. In this case, the part number cannot be used in the claim and the \$1,000 must be claimed as sublet 03 and will only be paid with documentation of proof of sale of the accessory/s in the warranty claim. This is not to be used as a voucher or cash payment to the customer and only applies to genuine BMW Motorrad accessories for R 18 models.

TREAD Act**TREAD Act Reimbursement - Qualifying Prior Customer-Pay Repairs**

If your center is presented with a reimbursement request, BMW of North America, LLC will reimburse qualifying customer-pay repairs that were performed on affected vehicles up to 10 days after the date the owner notification letter was sent out by BMW.

If the customer previously paid for a qualifying repair, verify in AIR that the VIN is affected by the recall campaign and proceed as applicable:

The customer arrives with an affected vehicle to your workshop

- Perform the open Recall repair outlined in this bulletin, regardless of previous repair history.
- If the prior repair qualifies (see below), submit for both the Recall repair and the customer-pay reimbursement (Separate repair line items/separate defect codes).

Copyright ©2025 MOTORRAD USA, a division of BMW of North America, LLC. All Rights Reserved

Or:

The customer only presents your center with a customer-pay invoice for the prior repair

- If the vehicle and the prior repair qualifies (see below), submit for the customer-pay reimbursement portion only.

Customer-pay Invoice Review and Reimbursement Qualification and Procedure

Review and verify that the prior customer-pay invoice (BMW center or independent repair shop) contains a repair that pertains to the recall campaign. Only the repair outlined in the published safety recall service bulletin is eligible for reimbursement.

If this prior repair qualifies, submit a claim for reimbursement:

- Verify in AIR that the VIN was affected by the recall campaign.
- Use defect code 85 99 00 45 NA for the amount requested under sublet 03.
- Comment: (RECALL 24V-716 Disable Reverser) - Reimbursement for allowable expenses that relate to performing the prior qualifying customer-pay repair.
- Use current repair date and mileage for claim submission.
- Retain copies of the customer paid invoice and the current repair invoice in your records.
- Reimburse the customer directly (parts and labor).

Contact warranty via an IDS ticket with any questions.

Retain the original customer pay invoice in your files; this documentation may be requested by BMW during the claim review process.

Note: A repair performed on a non-affected vehicle, or the diagnosis and repair of other unrelated issues do not qualify for reimbursement.

This claim submission for the prior customer-pay reimbursement, when it is submitted as outlined under Defect Code 85 99 00 45 NA, **will not close** the Open Safety Recall on the vehicle.

QUESTIONS REGARDING THIS BULLETIN

Technical inquiries	Contact the BMW Technical Support Group via TSARA
Warranty inquiries	Submit an IDS ticket to the Warranty Department
Parts inquiries	Submit an IDS ticket to the Motorrad Parts Department

Supporting Materials

[picture_as_pdf 61 09 24 - Recall 24V-716 Deactivate Reverser.pdf](#)

[picture_as_pdf Customer Disclosure Letter - Reverser.pdf](#)

[picture_as_pdf RM_0060437_0L11_EN.pdf](#)

[picture_as_pdf 61 09 24 - Recall 24V-716 - Deactivate Reverser.pdf](#)

Service Information Bulletin

General Electrical Systems

Sept 27, 2024

61 09 24

RECALL 24V-716 DISABLE REVERSER



**BMW
MOTORRAD**

MODEL

Model	Model Description	Model Code
K34	R 18	0L13
K34	R 18 Classic	0L23
K34	R 18 Roctane	0N63
K35	R 18 Bagger	0L33
K35	R 18 Transcontinental	0L43

The affected vehicles have been marked with campaign number **0000611900** in AIR.

In order to determine if a specific motorcycle is affected by this campaign, it will be necessary to verify the vehicle VIN in AIR (Aftersales Information Research). Based on the response of the system, either proceed with the repair or take no further action. Please note, open campaigns or vehicle stops may not appear in DCS Warranty Vehicle Inquiry or sales systems until 24-72 hours after they are announced, therefore AIR is always the recommended method for determining open campaigns and vehicle stops.

SITUATION

After quality inspection, BMW Motorrad has found that due to insufficient sealing of the reverser control unit, moisture can leak into the control unit. This can lead to corrosion of electrical contacts inside the control unit over time and under certain warm-humid (all year round) climatic conditions. This corrosion can result in a failure of the reverser function.

In rare cases, high resistance creating high amperage can occur between the corroded contacts, resulting in overheating of the components that could develop into thermal damage to the control unit.

The affected vehicles have been placed under the delivery stop **STOP610019** associated with campaign number 0000611900, which will be lifted upon completion of this technical campaign.

PROCEDURE

For vehicles that have not been delivered, the Recall must be carried out before delivery to customers and during the retail process the disclosure letter (attached below) must be signed by the customer and dealer representative. Two copies must be made with one provided to the customer at the time of retail and the other to be placed in the vehicle file.

For vehicles already retailed, Customer recall letters are being mailed to owners via First Class mail advising them of this recall and asking them to schedule an appointment with an authorized BMW Motorrad dealer to have the recall procedure performed. The customer must be made aware the reverser function is disabled and the disclosure letter (attached below) must be signed by the customer and dealer representative.

As an interim repair measure to prevent thermal damage, the reverser control unit must be disabled in accordance with AIR repair instructions “00 60 437 – Permanently disconnecting reverser control unit from wiring harness”.

NOTE: The removed cables must be destroyed, then scrapped and must not be returned to the customer.

Customer Disclosure Letter

Attached below is a customer disclosure letter.

For new customers at time of sale of the motorcycle with reverser disabled:

- The disclosure must be reviewed and signed by the customer and dealer representative.
- A copy must be made and provided to the purchasing customer.
- The original should be filed in the dealer’s vehicle file.

For current customers having the reverser disabled:

- The disclosure must be reviewed and signed by the customer and dealer representative during the service visit.
- A copy must be made and provided to the customer when picking up the motorcycle.
- The original should be filed in the dealer’s vehicle file.

Customer Compensation for New And Used Vehicle Customers:

As compensation for the temporary loss of use of the reverser feature, you can offer the customer up to \$1,000 (parts cost plus handling) in genuine BMW Motorrad accessories for R 18 models. Claim information is listed below.

This compensation offer applies until the improved reverser control unit is available for replacement and the final repair bulletin is published.

The offer applies only to retailed units.

To claim for this compensation, the unit must have been RDR’d. The compensation does not apply to new or used unsold vehicle inventories.

NOTE: This is **not** a sales incentive. It is compensation to a customer for the temporary loss of a feature.

NHTSA STATEMENT

Please be reminded that it is a violation of federal law (The Safety Act) for you to sell, lease or deliver any new motorcycle covered by this notification until the recall repair has been performed. This means that dealers may not legally deliver new motorcycles to consumers until they are fixed or use/sell replacement equipment/parts subject to this recall. Note also that substantial civil penalties apply to violations of the Safety Act. Also, you should not sell, lease or deliver any used motorcycles subject to a safety recall until the repair is completed. Please follow any special instructions that we provide to you for the return or disposition of recall parts.

PARTS INFORMATION

Obtain and confirm the part numbers for your specific vehicle by entering the chassis number in ETK which takes into account specific equipment and/or options.

© 2024, BMW of North America, LLC. The contents of this document are confidential and should not be shared with third parties for distribution. All pricing subject to change.

Additional parts like gaskets, hardware and chemicals may be required for the complete repair.

Part Number

07 12 9 908 527	Cheese head screw (If necessary, see repair instruction)	QTY 2
-----------------	--	-------

CLAIM INFORMATION

Please submit claims via the normal claim process using the information below:

Defect Code

00 00 61 19 00	Disabling Reverser Control Unit
----------------	---------------------------------

Labor Operation

00 60 437	Disconnect control unit for reverser from the wiring harness	6 FRU
+00 60 937	Disconnect control unit for reverser from the wiring harness	5 FRU

FRUs includes all repair procedures to complete the task with allowance for necessary ancillary tasks (e.g., visual inspection, lubrication, cleaning parts etc.) and administrative tasks.

Labor operation code 00 60 437 is a Main labor operation. If you are using a Main labor code for another repair, use the Plus code labor operation instead.

Customer Compensation Claim and Parts Information

Defect Code

77 99 90 01 00	Customer Compensation for Recall Campaign 00 00 61 19 00
----------------	--

Part Number

77 XX X XXX XXX	Genuine BMW Motorrad Accessories for R 18 Models
-----------------	--

NOTICE: The permissible maximum compensation is \$1,000 (including parts cost plus handling) as a one-time settlement that applies only for genuine BMW Motorrad accessories for R 18 models.

In cases where the accessory/s that the customer wants exceeds the maximum \$1,000 (including parts cost plus handling) amount, the customer must pay the difference between the accessories cost and the max contribution amount. In this case, the part number cannot be used in the claim and the \$1,000 must be claimed as sublet 03 and will only be paid with documentation of proof of sale of the accessory/s in the warranty claim. This is not to be used as a voucher or cash payment to the customer and only applies to genuine BMW Motorrad accessories for R 18 models.

TREAD Act

TREAD Act Reimbursement - Qualifying Prior Customer-Pay Repairs

If your center is presented with a reimbursement request, BMW of North America, LLC will reimburse qualifying customer-pay repairs that were performed on affected vehicles up to 10 days after the date the owner notification letter was sent out by BMW.

If the customer previously paid for a qualifying repair, verify in AIR that the VIN is affected by the recall campaign and proceed as applicable:

The customer arrives with an affected vehicle to your workshop

- Perform the open Recall repair outlined in this bulletin, regardless of previous repair history.
- If the prior repair qualifies (see below), submit for both the Recall repair and the customer-pay reimbursement (Separate repair line items/separate defect codes).

Or:

The customer only presents your center with a customer-pay invoice for the prior repair

- If the vehicle and the prior repair qualifies (see below), submit for the customer-pay reimbursement portion only.

Customer-pay Invoice Review and Reimbursement Qualification and Procedure

Review and verify that the prior customer-pay invoice (BMW center or independent repair shop) contains a repair that pertains to the recall campaign. Only the repair outlined in the published safety recall service bulletin is eligible for reimbursement.

If this prior repair qualifies, submit a claim for reimbursement:

- Verify in AIR that the VIN was affected by the recall campaign.
- Use defect code 85 99 00 45 NA for the amount requested under sublet 03.
- Comment: (RECALL 24V-716 Disable Reverser) - Reimbursement for allowable expenses that relate to performing the prior qualifying customer-pay repair.
- Use current repair date and mileage for claim submission.
- Retain copies of the customer paid invoice and the current repair invoice in your records.
- Reimburse the customer directly (parts and labor).

Contact warranty via an IDS ticket with any questions.

Retain the original customer pay invoice in your files; this documentation may be requested by BMW during the claim review process.

Note: A repair performed on a non-affected vehicle, or the diagnosis and repair of other unrelated issues do not qualify for reimbursement.

This claim submission for the prior customer-pay reimbursement, when it is submitted as outlined under Defect Code 85 99 00 45 NA, **will not close** the Open Safety Recall on the vehicle.

QUESTIONS REGARDING THIS BULLETIN

Technical inquiries	Contact the BMW Technical Support Group via TSARA
Warranty inquiries	Submit an IDS ticket to the Warranty Department
Parts inquiries	Submit an IDS ticket to the Motorrad Parts Department

Original: Dealer (vehicle File)

Copy: Customer



**BMW
MOTORRAD**

Notice re: Reverser Control Unit

Dear Customer,

Thank you for your decision to purchase a BMW motorcycle.

Customer satisfaction is of paramount importance to BMW of North America. To promote this, quality checks are carried out regularly.

As a result of these efforts, we have found that due to insufficient sealing of the reverser control unit, moisture can leak into the control unit. This could lead to corrosion of electrical contacts inside the control unit over time and under certain climate conditions. This corrosion can result in a failure of the reverser function. And, in rare cases, this could result in thermal damage.

There is an interim repair measure to prevent this possible thermal damage. This involves disabling the reverser control unit until a replacement reverser control unit can be installed. Unfortunately, this means that your reverser function will not be available until the final remedy is available. That remedy will involve installation and activation of a new reverser control unit at no cost to you once available.

Notice To Purchaser/Owner:

The motorcycle (VIN: _____) that is being/was purchased does not currently have the reverser function because it has been disabled in order to prevent possible thermal damage to the unit. There are no restrictions otherwise in regard to the use of your motorcycle. However, the reverser control unit should not be reconnected until your dealer completes this repair for you when the final repair is available.

I confirm the information above was provided to me.

DATE: _____

Printed Name: _____

Signature: _____

Dealer Representative: _____

Company BMW of North America, LLC
Postal address BMW Motorrad USA
200 Chestnut Ridge Rd.
Woodcliff Lake, NJ 07677-7731

Office address
200 Chestnut Ridge Rd.
Tel Switchboard +1 (800) 831-1117
Internet www.bmwmotorcycles.com

OL11 - R 18

00 60 437 Disconnect control unit for reverser from the wiring harness.

ATTENTION

Control unit has been damaged due to continuous power supply.

Risk of fire

- Permanently disconnect electrical control unit connection to vehicle.
- Prevent reconnection by unauthorised persons (destroy cables)

Additional work: 46 52 510 Mounting and dismounting the rear-wheel stand with special tools (for motorbikes without a centre stand)

1

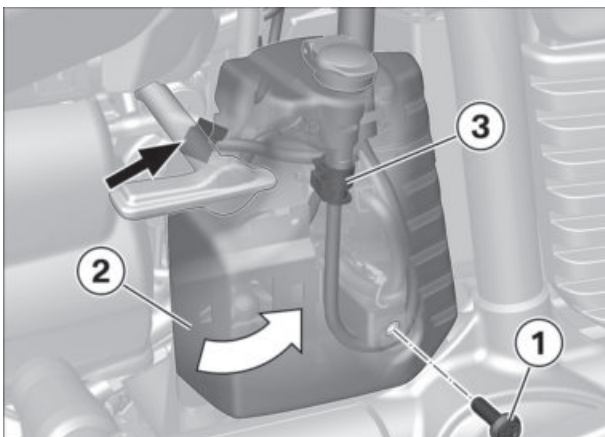

► Removing trim for Keyless Ride control unit

- Remove screw (1).
- Pivot trim (2) upwards and detach from holder (arrow).
- Disconnect connector (3).

2

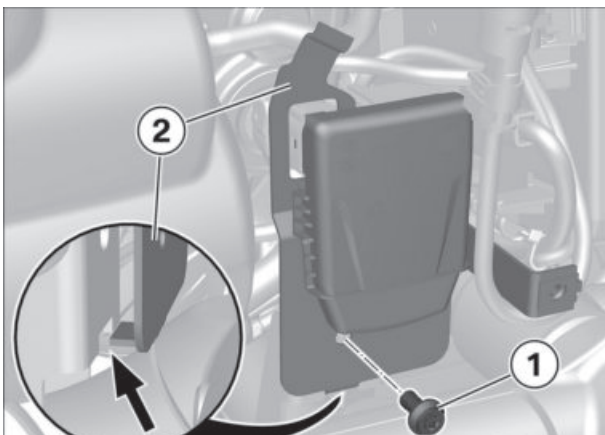

► Keyless Ride Removing the control unit with holder

- Remove bolt (1).
- Disengage holder (2) from hook (Arrow) and work clear.

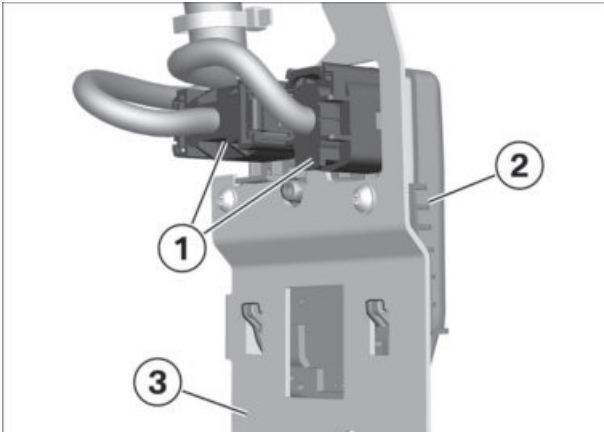

- Disconnect connector (1).
- Remove control unit (2) with holder (3).



3

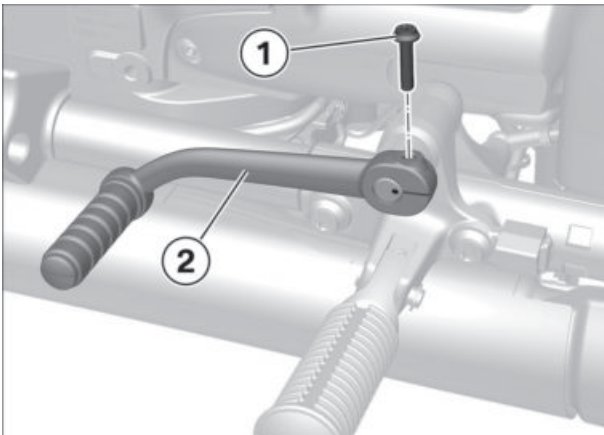

► Removing gearshift lever

- Remove bolt (1).
- Remove gearshift lever (2).

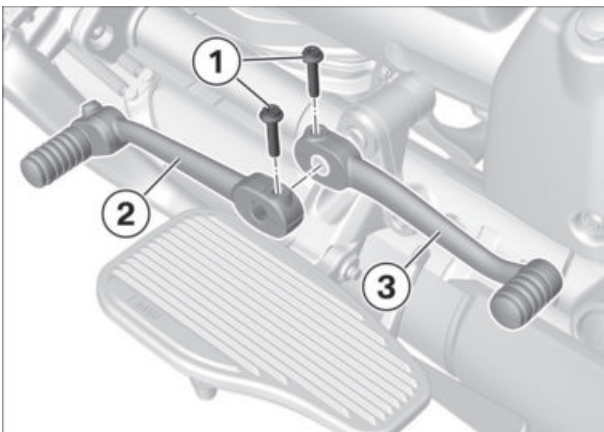

- with footboard^{OE} (036A)
- Remove screws (1).
- Remove gearshift lever (2) and (3).◇

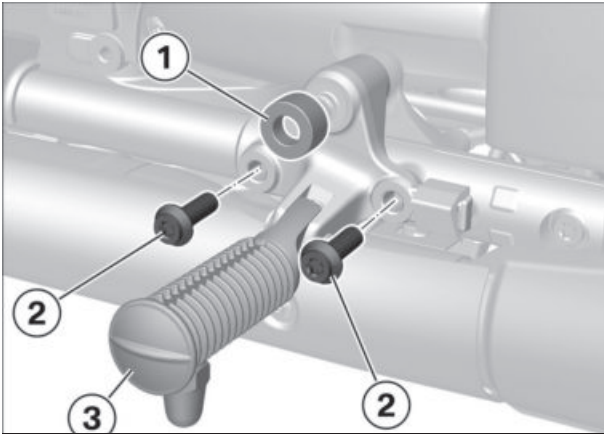

4

► **Removing front left footrest plate**

- Extend the side stand.
- Remove spacer sleeve **(1)**.
- Remove screws **(2)**.
- Remove the footrest plate **(3)**.

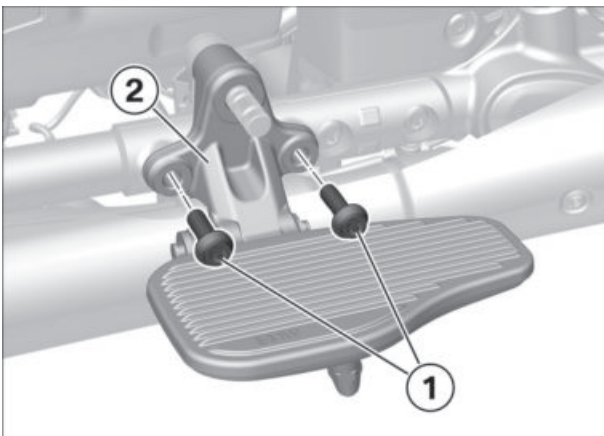

– with footboard^{OE} (036A)

- Extend the side stand.
- Remove screws **(1)**.
- Remove the footrest plate **(2)**.◇

5

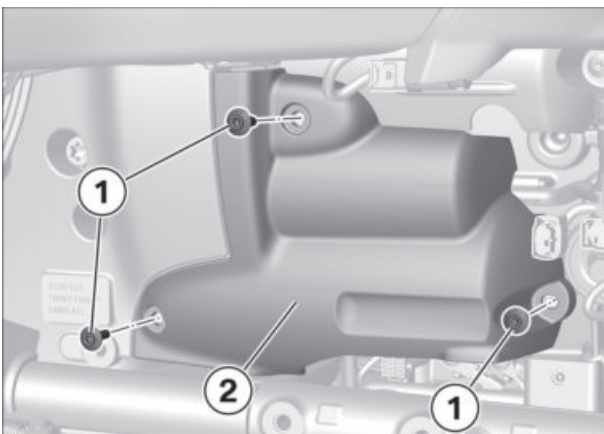
► **Removing cover for starter motor**

- Remove screws **(1)**.
- Remove cover **(2)**.

6

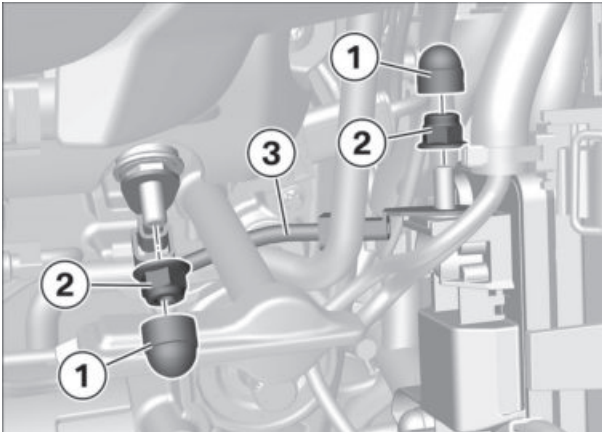

► **Removing cables to transmission housing and reverser**

- Remove protective caps **(1)** and nuts **(2)**.
- Remove cable **(3)**.
 - Positive cable to starter motor.
- Reinstall nuts **(2)** and protective caps **(1)** **without cable**.
 - Nuts and protective caps are required for subsequently enabling control unit.

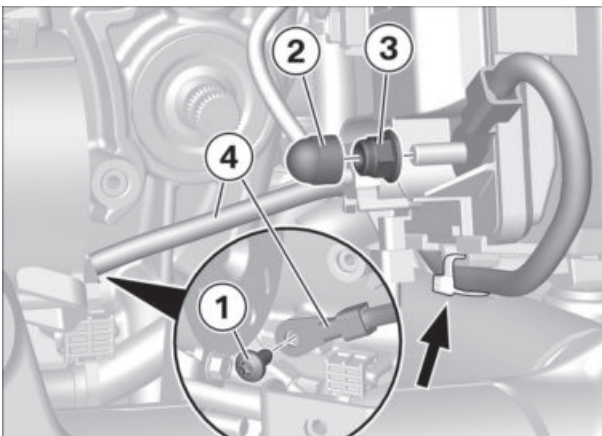

- Remove cable strap **(arrow)**.
- Remove screw **(1)**.
- Remove protective cap **(2)** and nut **(3)**.
- Remove cable **(4)**.
 - Ground cable to transmission housing.
- Reinstall screw **(1)**, nut **(3)** and protective cap **(2)** **without cable**.
 - Screw, nut and protective cap are required for subsequently enabling control unit.
- **Destroy cables to transmission housing and reverser, do not give them to the customer!**
 - Positive cable to wiring harness remains screwed to protective cap.
 - Connector remains connected to control unit.
- **Secure remaining cables** again using cable straps **(arrow)**.

7

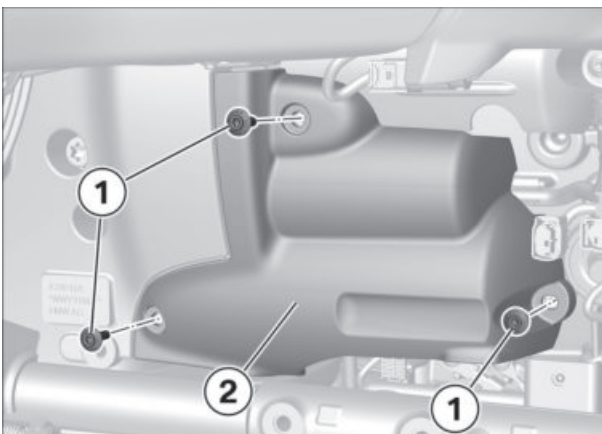

► **Installing cover for starter motor**

- Insert cover **(2)** and install bolts **(1)**.
 - 6 mm bolts with collar

8

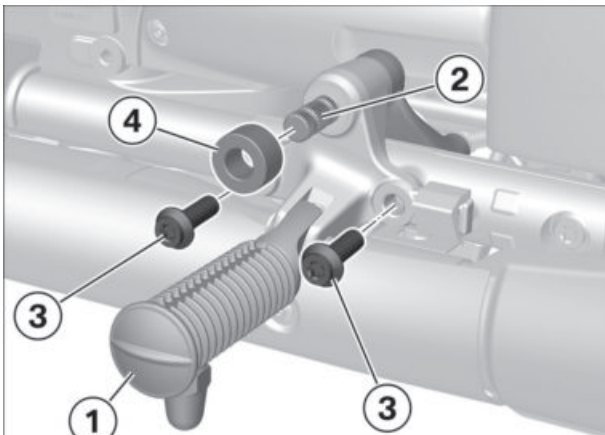

► **Installing front left footrest plate**

- Clean thread.

ATTENTION

Damage of the bearing due to lubricants.

Component damage, stiff movement

- Lubricants can damage the coating chemically.
- Lubricant bind dirt particles and increase the wear by this.
- A PTFE-bearing is maintenance free; do not lubricate the bearing.

- Attach footrest plate (1) on gearshift shaft (2).
- Install screws (3).

Tightening torques		
Footrest plate to frame bottom truss		
M10 x 30 - 10.9, Replace screw or use screw lock Thread-locking compound (micro-encapsulated), Thread-locking compound (Loctite 243, Medium strength)	56 Nm	

- Clean and install spacer sleeve (4).

– with footboard^{OE} (036A)

- Clean thread.

ATTENTION

Damage of the bearing due to lubricants.

Component damage, stiff movement

- Lubricants can damage the coating chemically.
- Lubricant bind dirt particles and increase the wear by this.
- A PTFE-bearing is maintenance free; do not lubricate the bearing.

- Attach footrest plate (1) on gearshift shaft (2).
- Install screws (3).

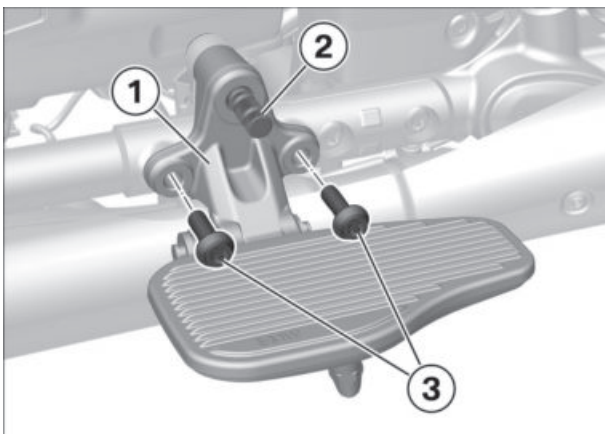

Tightening torques		
Footrest plate to frame bottom truss		
M10 x 30 - 10.9, Replace screw or use screw lock Thread-locking compound (micro-encapsulated), Thread-locking compound (Loctite 243, Medium strength)	56 Nm	



9

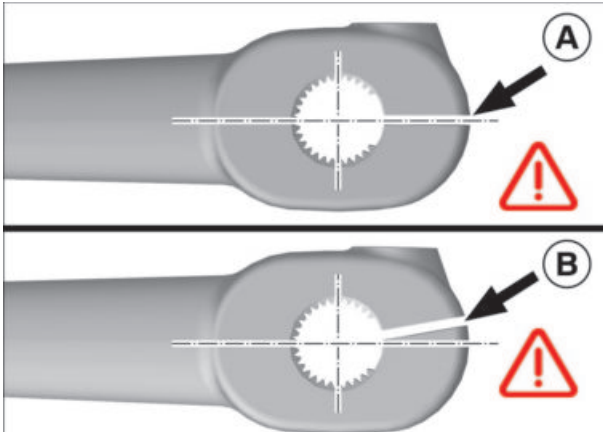

► **Installing gearshift lever**

- with footboard^{OE} (036A)
- Check build level of **outside** gearshift lever:
 - Build level A, groove in line: install gearshift lever offset to the bottom by one tooth.
 - Build level A, groove offset: install groove (gearshift lever) aligned with punch mark (shaft).◇

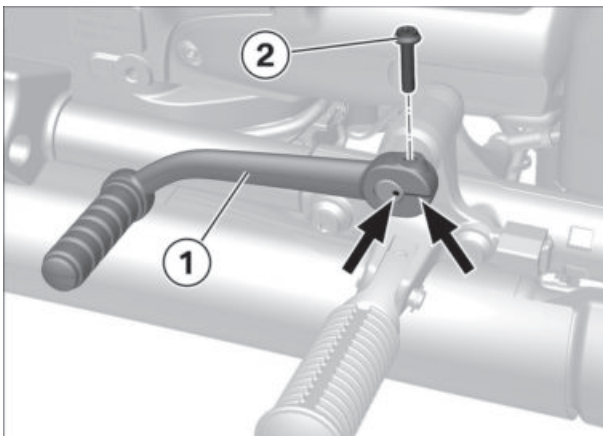

- Attach gearshift lever **(1)** aligning punch mark on groove **(arrows)**.
- Install screw **(2)**.

Tightening torques		
Gearshift lever to selector shaft		
M6 x 25	8 Nm	

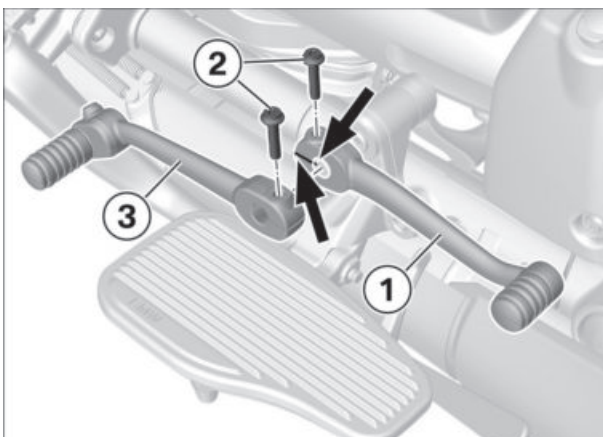

- with footboard^{OE} (036A)
- Attach gearshift lever inside **(1)** aligning punch mark on groove **(arrows)**.
- **Build level A:** Attach gearshift lever outside **(3)** aligning groove **with one tooth offset to the bottom** with punch mark on shaft.
 - » Clearance of gearshift lever outside when downshifting is ensured.
- **Build level B:** Attach gearshift lever **outside (3)** aligning groove on punch mark.
- Install screw **(2)**.

Tightening torques		
Gearshift lever to selector shaft		
M6 x 25	8 Nm	

10

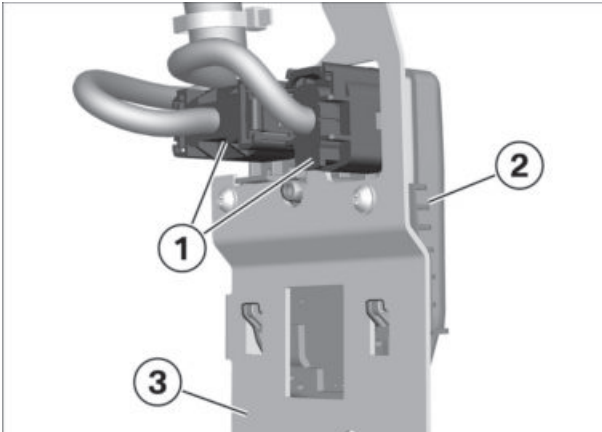

► **Keyless Ride Installing the control unit with holder**

- Connect connector (1) to control unit (2) and holder (3).

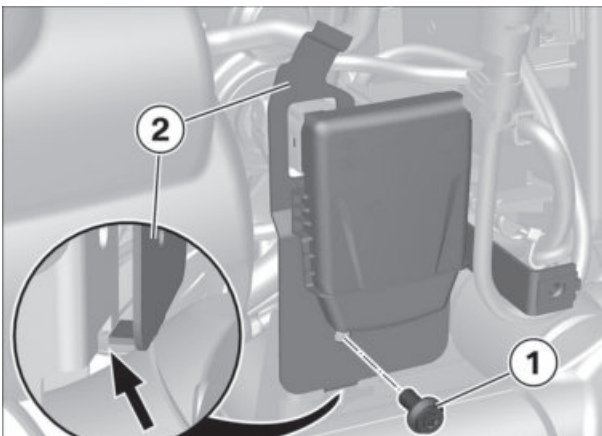

- Insert holder (2) and secure in hook (arrow).
- Install bolt (1).

11

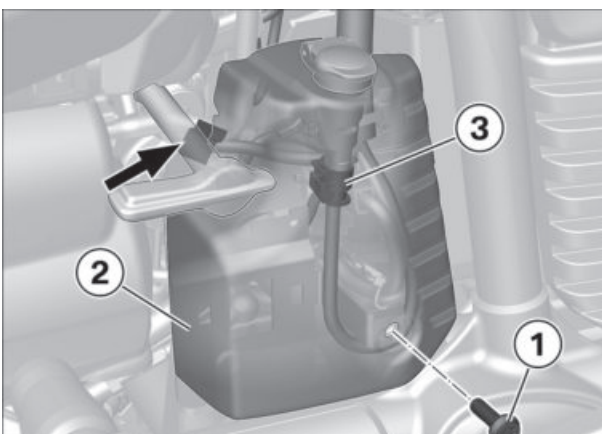

► **Installing trim for Keyless Ride control unit**

- Connect connector (3).
- Engage trim (2) in holder (arrow) and pivot down.
- Install screw (1).

12

► **Final inspection of completed work**

- Ensure the following:

- Cables have been destroyed.
- Reverser is no longer operational.
- The objective of the completed work was achieved.
- All operating fluids have been filled in and the fluids are at the correct fill level.
- All loosened screw connections have been retightened correctly.
- The fuel system is free of leaks.
- The lighting and signal system is functional and the vehicle is roadworthy.
- The brake pads of the front and rear wheel brakes are resting against the brake disks.

▷ **Function test, engine start suppression**

Check

- Select neutral.
 - » Neutral indicator light "N" lights up.
- Select a gear.
 - » Neutral indicator light "N" goes out.
- Operate the starter switch.
 - » Starter does **not** operate.
- Extend the side stand.
 - » Starter does **not** operate.
- Pull the clutch lever.
 - » Starter does **not** operate.
- Operate the starter switch.
 - » Starter does **not** operate.
- Retract the side stand.
 - » Starter does **not** operate.
- Operate the starter switch without releasing the clutch lever.
 - » Starter operates.

Result

Not all test steps completed successfully.

Measure

- Check corresponding components with BMW Motorrad diagnosis system.

