



SIB 32 05 24

2025-01-22

**RECALL 24V-714: STEERING SHAFT (DOUBLE UNIVERSAL JOINT)**

This Service Information Bulletin (Revision 5) replaces SI B32 05 24 **dated January 2024**.

**What's New:**

- Claim Information updated

Please perform the procedure outlined in this Service Information on all affected vehicles before customer delivery. In the event the customer has already taken delivery of the vehicle, please perform the procedure the next time the vehicle is in the shop if the campaigns have a status of remedy available. Otherwise, please release the vehicle.

**MODEL**

E-Series	Model Description	Production Date
G60	5 Series Sedan & i5 Sedan	June 17, 2024 – September 4, 2024
G70	7 Series Sedan & i7 Sedan	June 17, 2024 – September 4, 2024

**AFFECTED VEHICLES**

Vehicles which require this campaign to be completed will show it as “Open” when checked either in AIR, AWP, Campaign Summary, or Warranty Vehicle Inquiry.

Please make sure you check your dealer inventory as soon as possible. As of September 19, 2024, you can see a list of affected vehicles in Inventory Campaign Details (ICD) under ROSS.

**SITUATION**

BMW AG has issued a Delivery Stop (effective September 18, 2024) on certain Model Year 2024 - 2025 BMW vehicles that were produced between June 17, 2024, and September 4, 2024.

As of September 25, 2024, this Delivery Stop has been upgraded to a Safety Recall.

During certain steering maneuvers, the steering spindle could become damaged and break. In rare cases, a larger steering effort could be unexpectedly needed, which could increase the risk of a crash.

Do not deliver to a customer, a New, Certified Pre-Owned or Used vehicle subject to a Delivery Stop, until the vehicle is repaired. Do not use or sell replacement equipment/parts subject to a Delivery Stop.

The Recall Notice and FAQ have been attached for further information.

**CAUSE**

Manufacturing error of the double universal joint, also known as “universal joint” in REP; or “swivel joint” in ETK.

**CORRECTION**

Replace the double universal joint as per REP 32 31 210 “Replacing the universal joint”.

**NOTE: For vehicle which require the output shaft to be removed and installed. Ensure the proper installation of the output shaft to wheel bearing as shown in the photo below.**

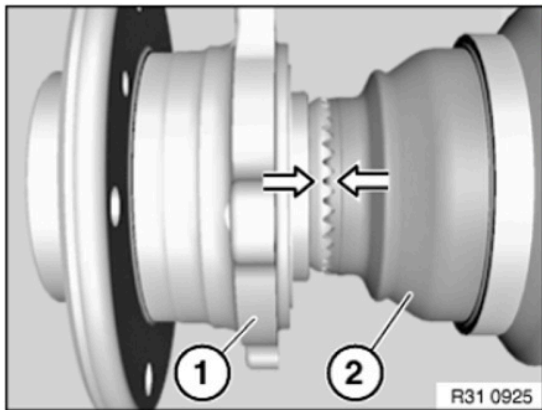

### i TECHNICAL INFORMATION

The front gearing of wheel bearing and driven shaft must be installed with a positive fit (tooth in tooth position).

- Ensure positive locking by twisting wheel bearing (1) and output shaft (2) against each other.

And, for the:

### G70 760i xDrive (AG MC 33EJ) New Repair Procedure

Per the latest version of the repair instruction, the front axle no longer needs to be removed and installed to access the universal joint, accordingly the:

- List of required parts has been reduced
- Labor operations' repair times have also been reduced (Plusposition 25 FRU / Main 27 FRU)

### Important Warning for Working on the High-Voltage (HV) systems on BMW Group vehicles:

**Only properly trained personnel, who passed all applicable HV Technical Training Courses, should perform repairs which require disconnecting, or removal of High Voltage battery components on any Hybrid or Electric Vehicle. Work performed on High Voltage systems by unqualified persons may result in severe injury or damage to the vehicle. Additional safety information is found in Repair Instruction 61 00... "Observe safety instructions when handling electric vehicles".**

**Prior to disconnecting, or the removal of any HV component, the HV system needs to be disabled and secured (by means of the HV Service Disconnect Switch and lock out) by a properly trained HV technician, who has a minimum HV Qualification level after completing the Technical Training Course "ST2324 High Voltage Drivetrain Systems" which as of 1/2023\* includes ST1824 Alternative Drive Part 1.**

**\* Note: As of January 2023, the HV component portion of the "ST2205 Generation 5 High-voltage class" (except for the High Voltage Battery) has been merged into "ST2324 High Voltage Drivetrain Systems".**

**Up to Generation 4 Vehicles once vehicle's HV system is disabled (the "Blitz" - lightning bolt icon is displayed in instrument cluster, see below), a technician without HV Certification may remove a HV component (e.g., EH Heater, EKK Compressor, EME Control Unit, et.), except for the High Voltage Battery.**

**For Generation 5 Vehicles however, the specific vehicle training is required to diagnose, remove and service any HV component and it is NOT allowed for non HV certified technicians to work on the high voltage system.**

**High Voltage Battery removal and rework can ONLY be performed by a High-voltage Certified Technician with a HV Battery Certification level corresponding to a specific Electric or Hybrid vehicle, for example:**

**To repair GEN4 HV battery of G05 PHEV a certification from Technical Training Course "ST2006 – SP44 HV Battery" or equivalent ST1825 – Alternative Drive Part 2 is required (or as of 1/2023 the equivalent "ST 2325 for High Voltage Battery Systems").**

Copyright ©2025 BMW of North America, Inc.

**And**

To repair A GEN5 HV battery the Technical Training Course “ST2205 Generation 5 High-voltage class” is required or as of 1/2023\* the equivalent “ST 2325 for High Voltage Battery Systems”.

\*Note: As of January 2023, the “ST2205 Generation 5 High-voltage stand-alone class” has been merged into “ST2324 for High Voltage Drivetrain Systems” and “ST2325 for High Voltage Battery Systems”

**PARTS INFORMATION**

Only use and invoice the applicable part numbers below.

**For G60/G70 without S68T**

Part Number	Description	Quantity
32 30 5 B6C 2A5	Swivel joint	1
32 30 6 778 609	Torx bolt (M8 x 33)	2

**For G70 740i xDr, i750 BEV**

Part Number	Description	Quantity
32 30 5 B6C 2A5	Swivel joint	1
32 30 6 778 609	Torx bolt (M8 x 33)	2
07 14 7 483 888	Hex bolt M10 x 55 bolt, strut brace	4

**For G70 BEV i760x, i7 M70**

Part Number	Description	Quantity
32 30 5 B6C 2A8	Swivel joint	1
32 30 6 778 609	Torx bolt (M8 x 33)	2
07 14 7 483 888	Hex bolt M10 x 55 bolt, strut brace	4

**For G70 with S68T**

Part Number	Description	Quantity
32 30 5 B6C 2A7	Swivel joint	1
32 30 6 778 609	Torx bolt (M8 x 33)	2
07 14 7 283 812	Plug-in nut (M10-10 ZNS3)	2
31 11 6 899 302	Multi-purpose bolt (10x45 ZNS3)	12
18 30 9 504 710	Gasket	2
18 30 7 597 650	Collar nut (M8)	8
18 30 7 843 213	Gasket (cylinder bank 5-8- driver's side catalytic converter inlet)	1

**CLAIM INFORMATION**

Reimbursement for this Recall will be via normal claim entry utilizing the applicable work package information below and part numbers above that apply.

<b>Repair Code:</b>	<b>0032660300</b>	<b>G6x G7x Replacing double universal joint</b>
---------------------	-------------------	---

Below are the special flat rate labor operation code choices for this action.

**Completion before the first vehicle delivery to a customer (New in-stock/No in-service date), or the vehicle is already in the workshop for another reason and/or repair.**

Work Pkg	Labor Operation	Description (Plusposition)	Labor Allowance
# 1	00 77 648	Replace double universal joint	As applicable

**The vehicle arrives at your center and this Recall shows open (No other Main work will be performed or claimed during this workshop visit).**

Work Pkg	Labor Operation	Description (Main work)	Labor Allowance
# 2	00 77 100	Replace double universal joint	As applicable

Only one of the flat rate labor operation codes listed above can be used for claim submission and reimbursement. Also, only one Main work flat rate labor operation code can be claimed per workshop visit.

**Claim Repair Comments**

Only reference the SIB number and the work package (Pkg) number performed in the technician’s RO notes and in the claim comments (For example: B32 05 24 WP 1), unless otherwise required by State law.

**BMW Group’s AIR Application Resource for Flat Rate Labor Operation Codes**

To obtain the corresponding flat rate unit (FRU) allowance information from the BMW Group AIR application resource, start by entering the Chassis Number (last seven (7) characters of the VIN), and click on the “Search” icon. If the “Vehicle Selection” window displays two or more model possible vehicle choices, select the applicable Model, or enter the full VIN (17 characters) instead to proceed. Click on the “Flat Rate Units” button and enter a flat rate labor operation code number “without spaces” in the field to the right, click on the “Search” icon to display the corresponding listing of “Flat rate unit group details” that are available and their corresponding FRU allowances.

**Alternative Mobility Solution (AMS) for Vehicle Owners (RO and Claim Comments Required)**

This Recall’s repair qualifies for Alternative Mobility Solution (AMS) expense reimbursement, claim this item under the Repair Code noted above as follows:

Sublet Code 2 - Itemize the AMS sublet amount on the repair order and in the claim comment section.

Please refer to [SI B01 29 16](#) for additional information.

**Reimbursements of Comparable Recall Remedy Prior Customer-Pay Repairs (TREAD Act)**

Based on the issue, and the age of the Affected Vehicles being addressed by this Safety Recall Campaign, a reimbursement request for a qualifying prior customer-pay repair is not likely. However, a customer may still request the review of a repair that was performed on their vehicle which they paid for.

A qualifying customer pay repair, performed prior to the notification of Recall, must primarily be for a comparable recall remedy repair to replace either a damaged or broken steering spindle for the issue described in this Service Information Bulletin (Situation/Cause/Correction). Also, the repair must have been correctly, effectively, and completely performed as required by the applicable BMW Group approved repair standards and instructions (Procedure), including the required replacement part usage (Parts Information), for it to be considered and approved for reimbursement.

In the event of the above situation, please contact the Warranty department (include a legible copy of the invoice) through IDS by selecting Coverage, Policy, Coding Questions and Mileage Corrections. The Warranty department will respond to your inquiry accordingly.

**FEEDBACK REGARDING THIS BULLETIN**

Technical Feedback	To submit feedback for the technical topic of this bulletin: Submit your feedback in the rating box at the top of this bulletin
Warranty Feedback	To submit feedback for the CLAIMS section of this bulletin: Submit an IDS ticket to the Warranty Department, or use the chat available in the

Copyright ©2025 BMW of North America, Inc.

	Warranty Documentation Portal
Parts Feedback	To submit feedback for the PARTS section of this bulletin: Submit an IDS ticket to the Parts Department

Supporting Materials

[picture\\_as\\_pdf B320524 Recall Notice.pdf](#)

[picture\\_as\\_pdf B320524 24V-714-G60-70-90-SteeringSpindle-FAQ-\(25Sep2024\).pdf](#)



## **SAFETY RECALL NOTICE**

To: All Center Operators, Sales Managers, Service Managers, Parts Managers and Warranty Processors

RE: Recall 24V-714: Steering Shaft – B32 05 24

BMW AG has issued a Delivery Stop (effective September 18, 2024) on certain Model Year 2024 - 2025 BMW vehicles that were produced between June 17, 2024, and September 4, 2024.

As of September 25, 2024, this Delivery Stop has been upgraded to a Safety Recall.

**Please be reminded that it is a violation of federal law (The Safety Act) for you to sell, lease or deliver any new motor vehicle covered by this notification until the recall repair has been performed. This means that Centers may not legally deliver new motor vehicles to consumers until they are fixed or use/sell replacement equipment/parts subject to this recall. Note also that substantial civil penalties apply to violations of the Safety Act.**

**Also, you should not sell, lease or deliver any Certified Pre-Owned or used vehicles subject to a safety recall until the repair is completed.**

**Please follow any special instructions that we provide to you for the return or disposition of recall parts.**

We appreciate all your assistance with this Recall.

**Safety Recall**  
**24V-714**  
**Steering Spindle**  
**Model Year 2024-2025**  
**BMW 5 Series / i5, 7 Series / i7**  
**Issue Date: 09/25/2024**

**Q1. Which BMW Group models in the US are potentially affected by this Safety Recall?**

Certain Model Year 2024-2025 BMW 5 Series / i5 and 7 Series / i7 models in the US are potentially affected.

**Q2. What is the specific issue?**

During certain steering maneuvers, the steering spindle could become damaged and break. In rare cases, a larger steering effort could be unexpectedly needed, which could increase the risk of a crash.

**Q3. Why are other models / vehicles not included in this Safety Recall?**

Other models have a steering spindle with the appropriate specifications.

**Q4. Can I continue to drive my vehicle?**

Yes. However, when you are notified by BMW of this Safety Recall that a remedy is available, please contact an authorized BMW center to schedule an appointment as soon as possible. For the latest updates to this Safety Recall, please visit [bmwusa.com/recall](https://bmwusa.com/recall). **If you are not the only driver of this vehicle, please advise all other drivers of this important information.**

**Q5. How did BMW Group become aware of the issue?**

BMW Group became aware of the issue through its quality control procedures.

**Q6. How will I be informed of this Safety Recall?**

Owners of potentially affected vehicles will be notified via First Class mail advising them of this Safety Recall and to schedule an appointment with an authorized BMW center as soon as possible to have the remedy performed. For the latest updates to this Safety Recall, please visit [bmwusa.com/recall](https://bmwusa.com/recall).

To ensure BMW has the most up-to-date contact and vehicle information, owners should register their vehicle at [bmwusa.com/myBMW](https://bmwusa.com/myBMW). Registration is free and will give them access to other information specific for their BMW vehicle. Alternatively, owners can visit [bmwusa.com/recall](https://bmwusa.com/recall) and click on “**Manage recall notices and contact information**”.

**Q7. How will my vehicle be remedied?**

The steering spindle will be replaced for free which should take several hours.

**Q8. Do I have to wait for BMW to contact me to have the remedy performed?**

Yes. We are in the process of implementing this Safety Recall to ensure that the necessary parts, tools, and procedures are available. For the latest updates to this recall, please visit [bmwusa.com/recall](https://bmwusa.com/recall).