

# Safety Recall

## N242466950 Potential Brake Line Leak



**Release Date:** October 2024

**Revision:** 01

**Revision Description:** This bulletin has been revised to add a new labor code for vehicles that do not use GM-supplied body mounts and an update has been made to the procedure. Please discard all previous copies of bulletin N242466950.

**Attention:** This bulletin contains an inspection procedure for both dealer inventory and customer vehicles. Vehicles that pass the inspection procedure contained in this bulletin can be sold and delivered to the customer.

**Vehicles that DO NOT PASS the inspection procedure contained in this bulletin cannot be sold or delivered to the customer.** When parts become available, a revision will be made to this bulletin to allow for the repair of these vehicles, and reimbursement under the Working Capital Assistance Program may also be added for vehicles which did not pass the inspection procedure.

**Vehicles that pass the inspection with no further action required can be delivered and closed using the “Inspect Only – Vehicle Passed Inspection (No Further Action Required)” labor code 9107636 or “Inspect Only – Vehicle Passed – Does not use GM-supplied body mounts (No Further Action Required)” labor code 9107444.**

**Vehicles that passed the inspection due to prior non-GM dealer repair but will require future line replacement can be delivered and the recall will remain open until the line is replaced in the future. Please submit under labor code 9106731 “Inspect Only – Vehicle Passed Due to Prior Repair but Will Require Future Line Replacement – claim submission will not close field action”.**

It is a violation of Federal law for a dealer to deliver a new motor vehicle or any new or used item of motor vehicle equipment (including a tire) covered by this notification under a sale or lease until the defect or noncompliance is remedied.

All involved vehicles that are in dealer inventory must be held and not delivered to customers, dealer traded, or used for demonstration purposes until the inspection procedure contained in this bulletin has been performed on the vehicle and passed.

Make	Model	Model Year		RPO	Description
		From	To		
Chevrolet	Express	2013	2017	BNC and JL4	PARTS PKG – BODY MOUNT CUSHIONS and CONTROL,-ACTIVE BRAKE
GMC	Savana	2013	2017	BNC and JL4	PARTS PKG – BODY MOUNT CUSHIONS and CONTROL,-ACTIVE BRAKE
Chevrolet	Express	2018	2019	BNC	PARTS PKG – BODY MOUNT CUSHIONS
GMC	Savana	2018	2019	BNC	PARTS PKG – BODY MOUNT CUSHIONS

Involved vehicles are marked “Incomplete. Remedy Not Available” on the Investigate Vehicle History screen in GM Global Warranty Management system. This site should always be checked to confirm vehicle involvement prior to beginning any required inspections and/or repairs.

<b>Condition</b>	General Motors has decided that a defect which relates to motor vehicle safety may exist in certain 2013 – 2019 model year Chevrolet Express Cutaway and GMC Savana Cutaway vehicles with optional GM-provided body mounts (RPO BNC). The brake lines in these cutaway vehicles may not meet the recommended clearance to the GM-provided body mounts. If brake lines contact the body mounts, the brake line may experience wear or damage that could lead to a brake fluid leak. A brake fluid leak can result in reduced stopping performance or inoperative service brakes, increasing the risk of a crash.
<b>Correction</b>	Dealers will inspect and, if necessary, replace the brake lines.

### Parts

No parts are required for this inspection.

# Safety Recall

## N242466950 Potential Brake Line Leak



### Warranty Information

Labor Operation	Description	Labor Time	Trans. Type	Net Item
9107636	Inspect Only – Vehicle Passed Inspection (No Further Action Required)	ST	ZFAT	N/A
9107637	Inspect Only – Vehicle Did Not Pass Inspection and Will Require Repair – claim submission will not close field action	ST	ZFAT	N/A
9106731	Inspect Only – Vehicle Passed Due to Prior Repair but Will Require Future Line Replacement – claim submission will not close field action	ST	ZFAT	N/A
9107444	Inspect Only – Vehicle Passed – Does not use GM-supplied body mounts (No Further Action Required)	0.2	ZFAT	N/A
9107638	Customer Reimbursement Approved - For USA and Canada dealers only	N/A	ZFAT	*
9107639	Customer Reimbursement Denied – For USA dealers only	N/A	ZFAT	**

**Important: Please select the appropriate labor code when submitting the claim. 9107636 or 9107444 should only be used if the vehicle PASSED the inspection and no further action is required. 9106731 should only be used if the vehicle passed due to prior repair, but will require future line replacement.**

**Note: When parts become available and the revised bulletin is released, reimbursement under the Working Capital Assistance Program may be included for vehicles which did not pass the inspection procedure.**

Note: To avoid having to “H” route the customer reimbursement transaction for approval, it must be submitted prior to the repair transaction.

\* For USA & Canada: Submit the dollar amount reimbursed to the Customer in Net/Reimbursement. Submit \$20.00 USD (\$25.00 CAD) administrative allowance in Net/Admin Allowance.

\*\* Submit \$10.00 USD administrative allowance in Net/Admin Allowance.

### Service Procedure



6748277

- Inspect the vehicle to see if it uses U-bolt style rear body mounts.
  - If the vehicle uses U-bolt style rear body mounts, no further action is required. Close the field action using 9107444 “Inspect Only – Vehicle Passed – Does not use GM-supplied body mounts” labor op.

## Safety Recall

### N242466950 Potential Brake Line Leak



- If the vehicle DOES NOT use U-bolt style rear body mounts, proceed to step 2.
2. Lift the vehicle. Refer to *Lifting and Jacking the Vehicle* in SI.
  3. If the vehicle is equipped with fuel tank mounted along the driver's side frame drop the fuel tank. Refer to *Fuel Tank Replacement (Chassis Cab, Front Tank)* in SI.

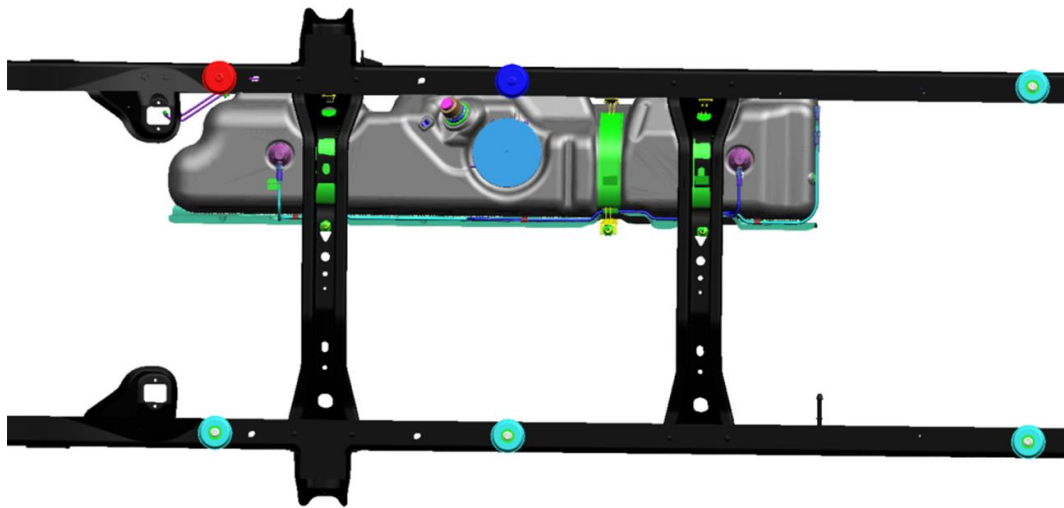

6737783

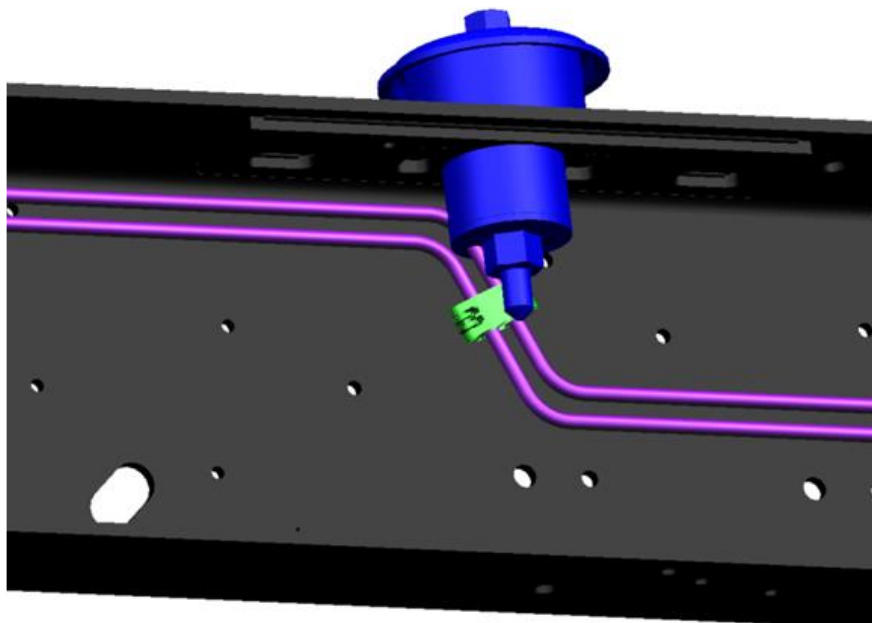

6737784

## Safety Recall

### N242466950 Potential Brake Line Leak



**IMPORTANT:** Do NOT attempt to bend or modify the brake lines if there is insufficient clearance. Close the field action with the "Inspect Only – Vehicle Did Not Pass" labor op per the instructions and wait until parts are available for repair.

4. Inspect the brake lines near the forward body mount (indicated by the color blue in the above pictures) and ensure that there is at least ½ inch (13mm) of clearance between the body mount and the brake lines.
  - If there is NOT at least ½ inch (13mm) of clearance, claim the "Inspect Only – Vehicle Did Not Pass" labor operation and park the vehicle until parts are available.
  - If there is at least ½ inch (13mm) of clearance, proceed to step 5.

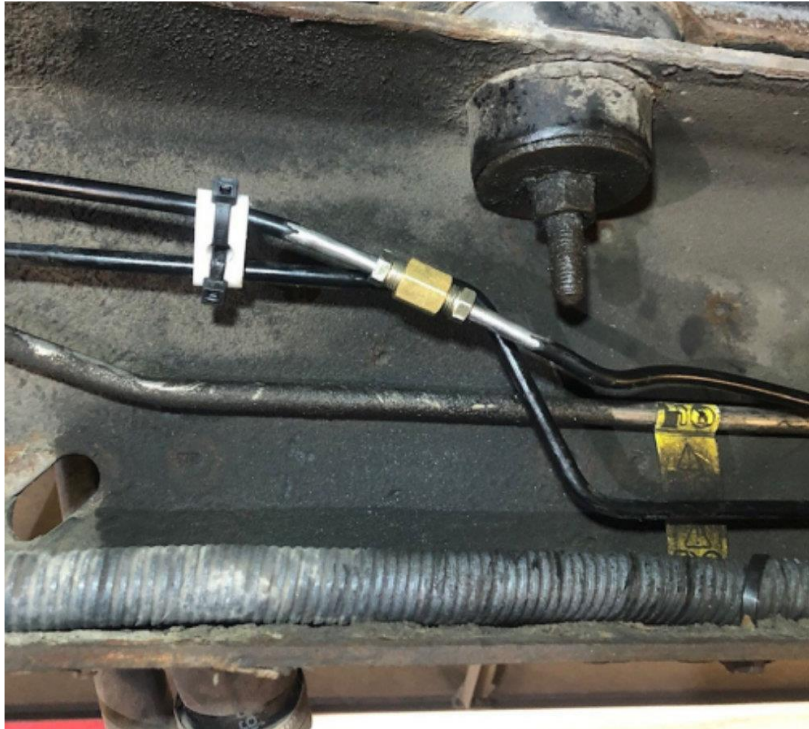

6737867

- If the vehicle has been repaired prior to inspection, as shown or similar, the vehicle is safe to drive. However, the brake lines should still be replaced when new parts are available. Continue to inspecting the rear mount in the next step, but if rear mount clearance is OK, you may claim the "Inspect Only – Vehicle Passed Due to Prior Repair" labor op.

## Safety Recall

### N242466950 Potential Brake Line Leak

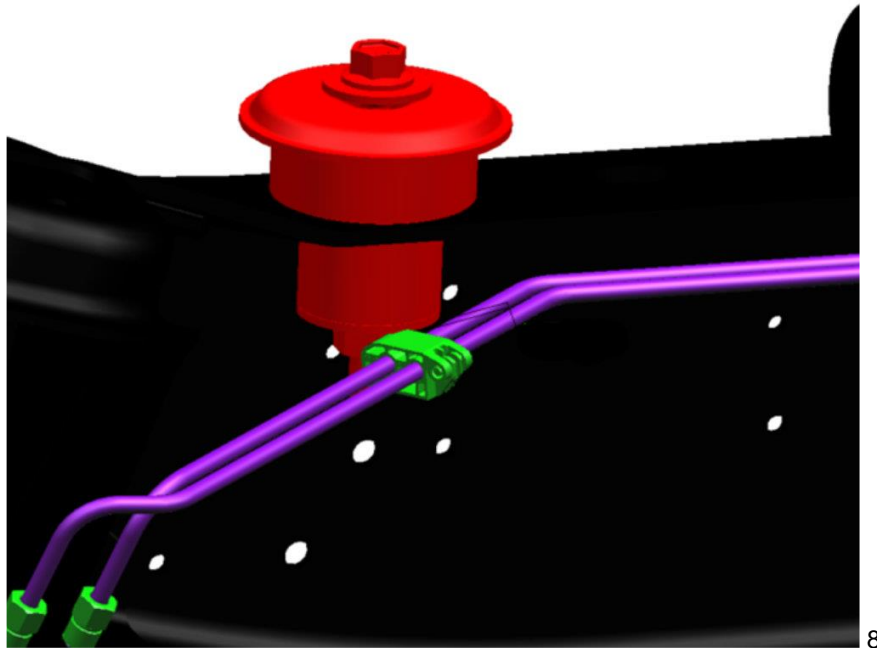

**IMPORTANT:** Do NOT attempt to bend or modify the brake lines if there is insufficient clearance. Close the field action with the “Inspect Only – Vehicle Did Not Pass” labor op per the instructions and wait until parts are available for repair.

5. Inspect the brake lines near the rearward body mount (indicated by the color red in the first picture of the procedure and above) and ensure that there is at least ½ inch (13mm) of clearance between the body mount and the brake lines.
  - If there is NOT at least ½ inch (13mm) of clearance, claim the “Inspect Only – Vehicle Did Not Pass” labor operation and park the vehicle until parts are available.
  - If there is at least ½ inch (13mm) of clearance, proceed to step 6.
6. Reinstall the fuel tank. Refer to *Fuel Tank Replacement (Chassis Cab, Front Tank)* in SI.
7. Lower the vehicle. Refer to *Lifting and Jacking the Vehicle* in SI.

#### **Dealer Responsibility** – For USA & Export (USA States, Territories, and Possessions)

It is a violation of Federal law for a dealer to deliver a new motor vehicle or any new or used item of motor vehicle equipment (including a tire) covered by this notification under a sale or lease until the defect or noncompliance is remedied.

The US National Traffic and Motor Vehicle Safety Act provides that each vehicle that is subject to a recall of this type must be adequately repaired within a reasonable time after the customer has tendered it for repair. A failure to repair within sixty days after tender of a vehicle is prima facie evidence of failure to repair within a reasonable time. If the condition is not adequately repaired within a reasonable time, the customer may be entitled to an identical or reasonably equivalent vehicle at no charge or to a refund of the purchase price less a reasonable allowance for depreciation. To avoid having to provide these burdensome remedies, every effort must be made to promptly schedule an appointment with each customer and to repair their vehicle as soon as possible. In the recall notification letters, customers are told how to contact the US National Highway Traffic Safety Administration if the recall is not completed within a reasonable time.

#### **Dealer Responsibility** – All

All new, used, GM Certified Pre-Owned (CPO), courtesy transportation vehicles, dealer shuttle vehicles, CarBravo, etc. in dealers' possession and subject to this recall must be held and inspected/repared per the service procedure of this bulletin before customers take possession of these vehicles. Involved vehicles must be held and not delivered to customers, dealer-traded, released to auction, used for demonstration, or any other purpose.

# Safety Recall

## N242466950 Potential Brake Line Leak



All GM Certified Pre-Owned (CPO) vehicles currently in the dealers' inventory within the SHIFT Digital system will be de-certified and must be held and remedied per the service procedure in this bulletin. Upon submitting an accepted/paid warranty transaction in the Global Warranty Management (GWM) system, the vehicle can be re-certified for sale within the SHIFT Digital system, or once again be used in the Courtesy Transportation Program.

Dealers are to service all vehicles subject to this recall at no charge to customers, regardless of mileage, age of vehicle, or ownership, from this time forward.

Customers who have recently purchased vehicles sold from your vehicle inventory, and for which there is no customer information indicated on the dealer listing, are to be contacted by the dealer. Arrangements are to be made to make the required correction according to the instructions contained in this bulletin. Recall follow-up cards should not be used for this purpose, since the customer may not as yet have received the notification letter.

In summary, whenever a vehicle subject to this recall enters your vehicle inventory you must take the steps necessary to ensure the program correction has been made before selling the vehicle. In addition, for vehicles entering your facility for service, you are required to ensure the customer is aware of the open recall and make every reasonable effort to implement the program correction as set forth in this bulletin prior to releasing the vehicle.

### Dealer Reports – For USA

For dealers with involved vehicles, a listing has been prepared and will be available through GM GlobalConnect Maxis Field Action Reports or sent directly to export dealers. The Inventory tab of the dealer reports will contain VINs that apply to this recall. This information is intended to assist dealers with the **PROMPT COMPLETION** of these vehicles. The Customer In-Service tab will contain customer names and addresses from Motor Vehicle Registration Records. The use of such motor vehicle registration data for any purpose other than follow-up necessary to complete this recall may be a violation of law in several states.

### Customer Notification

USA & Canada - General Motors will notify customers of this recall on their vehicle.

### Customer Reimbursement

Customer requests for reimbursement of previously paid repairs to correct the condition described in the bulletin can be submitted at anytime to the dealer. See General Motors Service Policies and Procedures Manual (USA & Canada).

---

GM bulletins are intended for use by professional technicians, NOT a "do-it-yourselfer". They are written to inform these technicians of conditions that may occur on some vehicles, or to provide information that could assist in the proper service of a vehicle. Properly trained technicians have the tools, equipment, safety instructions, and know-how to do a job properly and safely. If a condition is described, **DO NOT** assume that the bulletin applies to your vehicle, or that your vehicle will have that condition. See your dealer for information on whether your vehicle may benefit from the information.



**We Support  
Voluntary Technician  
Certification**