

L62X-  
R.03.24

To: After Sales Official Network  
Subject: crash relevant bracket assembly  
Date: 31/10/2024  
Pages: 4



**Campaign code:**  
L62X-R.03.24

**Campaign name:**  
crash relevant bracket assembly

Model:  
Huracan Spyder

**Model Year:**  
24

**Markets:**  
USA

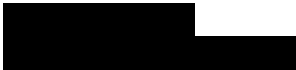

**Important information:** before proceeding with the repair, connect to the Warranty Portal and, using the “VIN Info” function, check that:

- the vehicle is actually affected by the instructions contained in this bulletin.

**NOTE:** some vehicles may not be affected, despite the fact that their Vehicle Identification Number (VIN) falls within the range;

- only replacement parts that correspond to the specific operation, identified by a letter (such as A, B, C, etc.), are to be used for the chassis being repaired.

Example

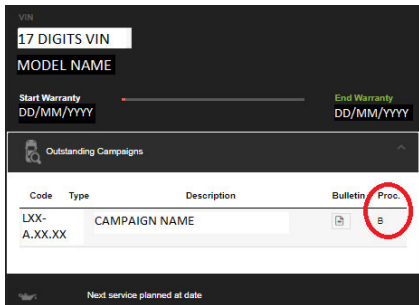

**NOTE:**

Operation A will be available only when the instructions require a preliminary check to be performed to determine whether or not the vehicle actually needs updating.

**Information for the service network:**

Automobili Lamborghini S.p.A. requires a verification of the correct assembly of the front reinforced bracket on Huracan Evo Spyder MY24 cars.

**Solution for the field:**

Check the correct mounting side of the bracket. If necessary, disassembly and reassembly the bracket on the correct side (left).

**Spare Parts:**

**OPERATION B**

Part number	Description	Q.ty
/	/	/

**Labor time:**

Operation B: 2.7h

**Previous bulletins superseded.**

None.

Rev.00

CONFIDENTIAL

The procedures and information published herein are strictly confidential and are intended exclusively for recognized professionals and persons who are authorized to receive said information. All copyrights are the property of Automobili Lamborghini S.p.A pursuant to copyright law. The company reserves the right to make updates and modifications as needed. The reprinting, reproduction, distribution to unauthorized persons and/or to third parties, and the partial or complete translation of the material contained herein are prohibited without the express written consent of Automobili Lamborghini S.p.A.

Doc. no.: L/V6\_M06 Rev.[07]



**Warranty claim instructions:**

To request reimbursement for the repair performed, access the “LIASS” system on the Lamborghini portal and, following the instructions in the system’s “Manuals” section, generate and fill out a Warranty Request. Select the required campaign and proceed with entry; carefully read the options present in the alert message that displayed by the system (see example) and select the option performed on the vehicle.

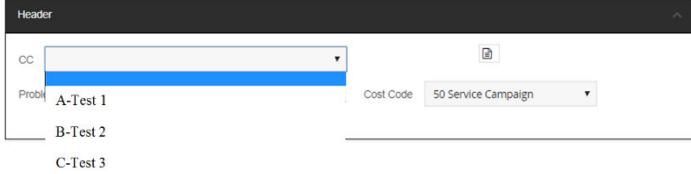

Reimbursement will be structured as follows, on the basis of the operation performed:

- **OPERATION B:**
  - o Steps to be executed: Operation B
  - o Labour time: 2.7 h

**Important information:**

attach all documents generated during the work carried out, evidence of the work itself, for instance work orders and diagnostic protocols with BETA-Reports.

If one or more of these is missing, it may lead to a rejected reimbursement request.

Fill out the page in the warranty booklet (identified in the image below) in the section “Service and Recall Campaigns”:

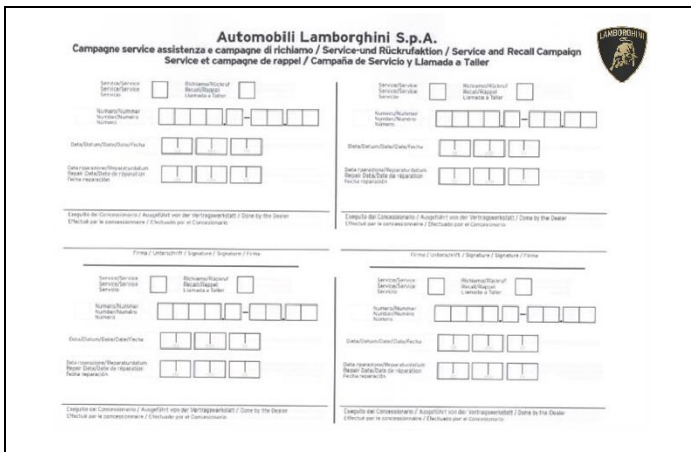

**Tools/Materials required**

Code	Description.	Q.ty
n\ a	n\ a	n\ a



**NOTE:**

All ODIS technical documentation can be viewed on the Lamborghini web portal, in the ODIS section.



**Repair method:**

**OPERATION B**

**Preliminary Operations**

To check that the reinforcement bracket (code 4T0803662) is correctly positioned, the front bumper must be completely disassembled.

Follow the procedure in the workshop manual:  
Select correct car: Huracan-->Spyder-->LP640-4-Evo Spyder-->MY24.

Follow the path:  
Body-->Exterior-->Front Bumper-->Front Bumper Components-->Complete Standard Front Bumper-->Removing.

**Procedure**

Check that the bracket 470803662 is correctly mounted on the right side of the car (See Figure 1 and 2).

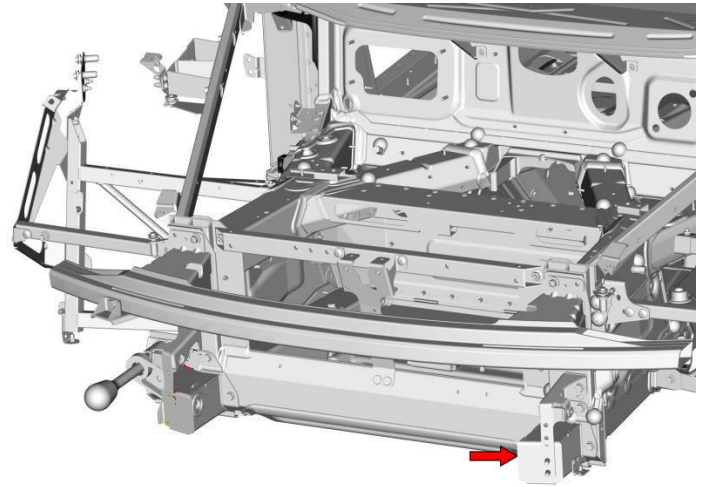

62xS21\_0000772

Figure – Incorrect Assembly (Case 2)

**CASE 1 – Bracket on the right side**

If the bracket is correctly located on the right side (Figure 1), the car can be reassembled by following the final steps.

**CASE 2 – Bracket on the left side**

If the bracket is mounted on the left side (wrong side - Figure 2), the bracket must be disassembled and reassembled correctly on the right side (correct side).

To do this, follow these steps:  
Select correct car: Huracan-->Spyder-->LP640-4-Evo Spyder-->MY24  
Follow the path:  
Body--> Frame-->Front--> Structural Components of Front Frame 1-->803.01.26-Front Chassis Brace

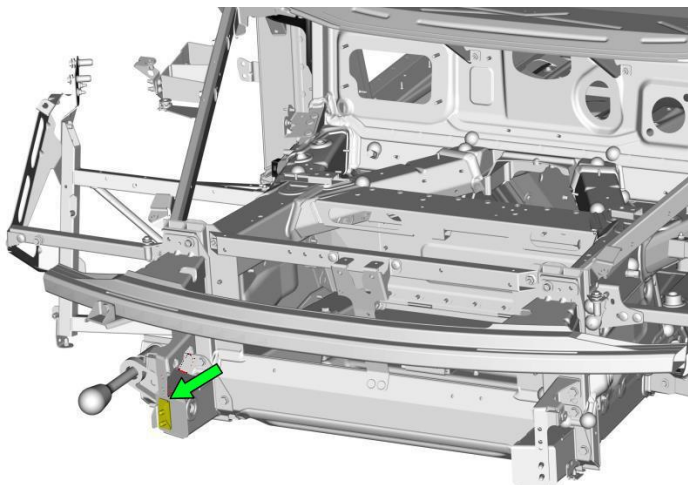

62xS21\_0000772

Figure 1 – Correct Assembly (Case 1)

L62X- R.03.24	<b>To:</b> After Sales Official Network <b>Subject:</b> crash relevant bracket assembly <b>Date:</b> 31/10/2024 <b>Pages:</b> 4	
------------------	--	--

**Final operations:**

Reassemble the front bumper.

Follow the procedure in the workshop manual:  
 Select correct car: Huracan-->Spyder-->LP640-4-  
 Evo Spyder-->MY24.  
 Follow the path:  
 Body-->Exterior-->Front Bumper-->Front Bumper  
 Components-->Complete Standard Front  
 Bumper-->Installing.



**IMPORTANT:**

*The documents which must be provided together with the operation under warranty request are:*

- *Produced Repair Order*
- *Saved Diagnostic Protocol wirh BETA report*

*Failure to follow these procedures could lead to the request being rejected.*

For more information, please contact your Area Manager or open a ticket to Technical Support in Lamborghini KEY (Request – General Information – After Sales Services - After Sales Technical Support).

Regards,  
*Lamborghini Service*

Rev.00  CONFIDENTIAL	The procedures and information published herein are strictly confidential and are intended exclusively for recognized professionals and persons who are authorized to receive said information. All copyrights are the property of Automobili Lamborghini S.p.A pursuant to copyright law. The company reserves the right to make updates and modifications as needed. The reprinting, reproduction, distribution to unauthorized persons and/or to third parties, and the partial or complete translation of the material contained herein are prohibited without the express written consent of Automobili Lamborghini S.p.A.	4/4  Doc. no.: L/V6_M06 Rev.[07]
----------------------------	---	--