

# SAFETY RECALL

Volvo Trucks North America

Greensboro, NC USA

---

Date	Number	Release	Page
09.2024	RVXX2407	01	1(4)

## Volvo Wheel Nut Torque VN, VHD

### RECALL INFORMATION

Volvo Trucks has determined that certain VN and VHD model trucks may have wheel nuts that were not torqued to specification. Insufficiently tightened lug nuts on the wheels may result in the loosening of the wheel attachment and potential wheel detachment from the vehicle. A wheel and tire assembly that detaches from a vehicle while driving may create a road hazard. If either were to occur, there would be an increased risk of injury or crash.

Volvo Trucks is requiring that all affected vehicles have all left/drivers side wheel nuts torqued to specification.

### VEHICLES AFFECTED

Certain 2025 Volvo VN and VHD model vehicles manufactured from August 19, 2024, through August 26, 2024.

### VEHICLE QUANTITY

There are 175 vehicles affected by this recall (156 U.S., 19 Canada).

## Repair Instructions

1. Park the vehicle on level surface.
2. Apply parking brake.
3. Place the transmission in park or neutral.
4. Turn off ignition.
5. Install wheel chocks.

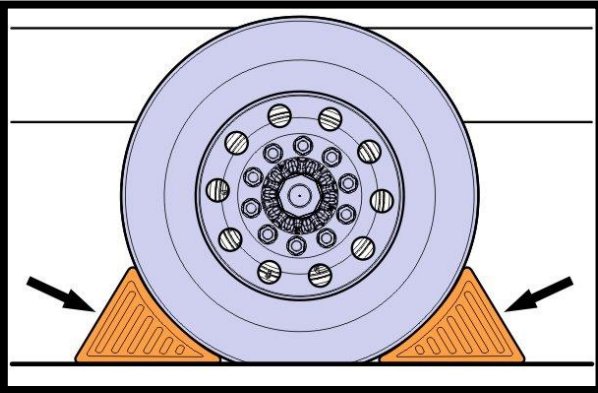

6. Lift all left side wheel ends and place on jack stands.

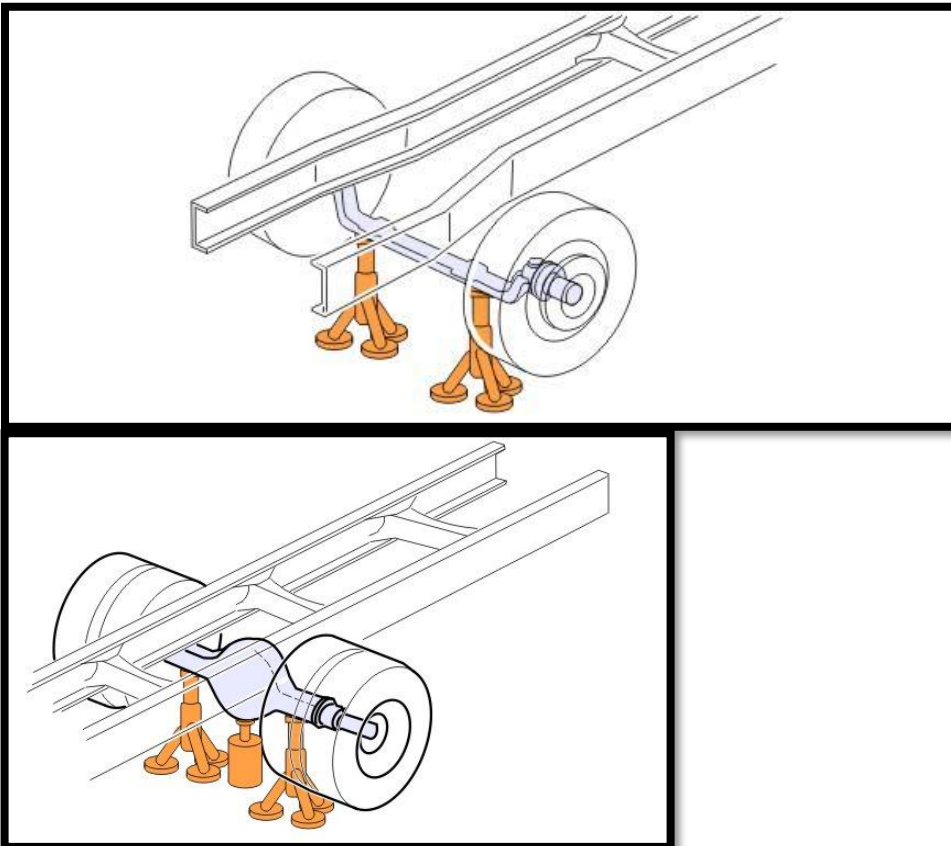

- Torque all left/drivers side wheel nuts to  $475 \pm 25$  ft-lb.

**Important Notes**

If any damage is found during repair, please repair as needed. Send an email to [campaign@volvo.com](mailto:campaign@volvo.com) detailing damage and repairs, please include pictures.

- Lift truck and removed jack stands.
- Remove wheel chocks.

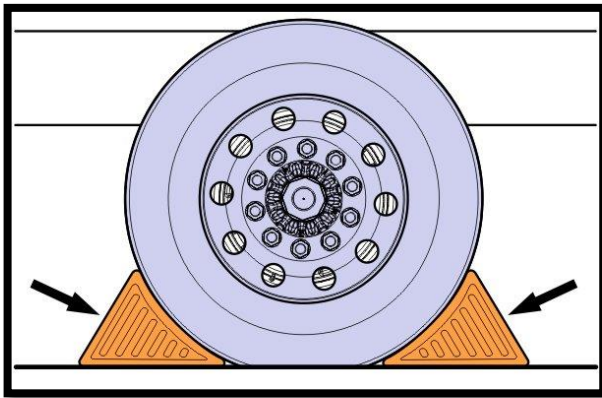

- Return truck to service.

**REIMBURSEMENT**

This repair is covered by an authorized safety recall. Reimbursement is obtained through the normal claim handling process.	
	UHP Reimbursement
Claim Type (used only when uploading from the Dealer Business System)	40
Recall Status	
Vehicle repaired per instructions	1-Modified per instructions
<b>Main Labor Codes 4X6 Truck Only</b>	
1720-16-09-01 Campaign General 0.1x9	0.9
<b>Main Labor Codes 4X2 Trucks Only</b>	
1720-16-09-01 Campaign General 0.1x6	0.6
Causal Part	21807998
Authorization Number	C0023

**Note:** Dealers are to perform this Safety Recall Campaign on all subject vehicles at no charge to the vehicle owner regardless of mileage, age of vehicle or ownership (original purchaser or subsequent purchasers). Whenever vehicles are subject to a Safety Recall are brought to your dealership for service, or taken into your dealership vehicle inventory, it is strongly recommended that every effort be made to perform the recall correction before the vehicle is sold or released to the owner.