

**SAFETY RECALL**  
 NORTH AMERICA  
**Instrument Panel Cluster**



Reference: 30B / NHTSA 24V-652

FCA US LLC



Remedy available for  
 2024 (JL) Jeep Wrangler  
 2024 (JT) Jeep Gladiator

Remedy NOT available for  
 2022-2023 (JL) Jeep Wrangler  
 2022-2023 (JT) Jeep Gladiator

Template Version 1.0

Revision	Edition	Detail
0	December 2024	Initial Version.

**SYMPTOM DESCRIPTION**

The Instrument Panel Cluster (IPC), on about 32,863 of the above vehicles may become blank. An IPC that fails to display critical safety information, such as the speedometer or warning lights can cause a vehicle crash without prior warning.

The condition above fails to conform to the requirements of Federal Motor Vehicle Safety Standard (FMVSS) 571.101, Controls and Displays S5.3 requires vehicles to "illuminate telltales and their identification sufficiently to make them visible to the driver under daylight and nighttime driving conditions." The IPC in the suspect vehicles may not illuminate the required telltales.

**SCOPE**

This recall applies only to the above vehicles equipped with a 3.5" Instrument Panel Cluster (IPC).

**NOTE:** Some vehicles above may have been identified as not involved in this recall and therefore have been excluded from this recall.

**IMPORTANT:**

- Some of the involved vehicles may be in dealer new vehicle inventory. Federal law requires you to complete this recall service on these vehicles before retail delivery. Violation of this requirement by a dealer could result in a civil penalty of up to \$27,168 per vehicle.
  - Some of the involved vehicles may be in dealer used vehicle inventory. Dealers should complete this recall service on these vehicles before retail delivery.
  - Dealers should also perform this recall on vehicles in for service.
- Involved vehicles can be determined by using the VIP inquiry process.

**REPAIR TO BE PERFORMED**

Replace the Instrument Panel Cluster (IPC).

**ALTERNATE TRANSPORTATION**

Dealers should proactively minimize customer inconvenience while the recall repair is being performed. Reference the Goodwill Alternate Transportation Guidelines warranty bulletin link within Recall Central on DealerCONNECT for options to support the customer while their vehicle is in service.

**COMPLETION REPORTING / REIMBURSEMENT**

Claims for vehicles that have been serviced must be submitted on the DealerCONNECT Claim Entry Screen located on the Service tab. Claims paid will be used by FCA to record recall service completions and provide dealer payments.

Use the following labor operation numbers and time allowances:

Labor Description	Number	Hrs
Replace IPC 2024 Model Year	08-30-B1-83	0.7

Labor Description	Number	Allowance
Floor Plan Reimbursement	95-95-95-97	Calculate See Below

Floor Plan Reimbursement represents the vehicle's average daily allowance (see table below) multiplied by the number of days the vehicle was in dealer inventory and not available for sale. This reimbursement is limited to the number of days from the date of the stop sale to the date that the remedy was made available. Note: If the vehicle was received by your dealership (KZX date) AFTER the stop sale date, you will use the KZX date instead of the stop sale date. For this Recall, the stop sale was initiated on 09/05/2024 and the remedy for 2024 model year vehicles was made available on 12/13/2024, therefore, the number of days cannot exceed 100 days.

Strictly respect STELLANTIS Group safety, cleanliness, and environmental instructions for any vehicle service. Document exclusively reserved for dealer information. Internal distribution to be ensured by dealer. Reproduction forbidden without the written agreement of STELLANTIS Group. (C) 2024 STELLANTIS Group. All Rights Reserved (tdb)

Vehicle	Average Daily Allowance
(JL) Jeep Wrangler	██████
(JT) Jeep Gladiator	██████

**NOTE: See the Warranty Administration Manual, Recall Claim Processing Section, for complete recall claim processing instructions.**

For Mobile Service Reimbursement, dealer to include standard dealer entry and mark-up for parts, standard dealer entry and labor rate for service, as well as the special services code for mobile allowance. The special services LOP will only be paid once per VIN and may NOT be used in coordination with any Alternate Transportation claims.

For additional details, reference the Mobile Service Warranty Bulletin - for convenience, a copy has been linked within Recall Central on DealerCONNECT.

**PARTS INFORMATION**

Refer to **Page 3** for appropriate IPC part number to be ordered for the vehicle.

**NOTE:** Exchange parts are ordered through the DealerCONNECT Exchange Order system, following this path: DealerCONNECT > Parts > Order Parts > Exchange Order Entry.

Ordering Additional Authorized Modification labels:

Part No.	Qty.	Part Name
04275086AE	1	Authorized Modification Label

**PARTS RETURN**

Return the instrument cluster to United Radio in the same box that the new cluster came in by following the standard core return policy. Please return as soon as possible to avoid charges.

**SPECIAL TOOLS**

Number	Description
NPN	wiTECH MicroPod II / MDP
NPN	Laptop Computer
NPN	wiTECH Software
NPN	Trim Stick

**DEALER NOTIFICATION**

To view this notification on DealerCONNECT, select “Global Recall System” on the Service tab, then click on the description of this notification.

**OWNER NOTIFICATION / SERVICE SCHEDULING**

All involved vehicle owners known to FCA are being notified of the service requirement by first class mail. They are requested to schedule appointments for this service with their dealers. A generic copy of the owner letter is attached.

**VEHICLE LISTS, GLOBAL RECALL SYSTEM, VIP AND DEALER FOLLOW UP**

All involved vehicles have been entered into the DealerCONNECT Global Recall System (GRS) and Vehicle Information Plus (VIP) for dealer inquiry as needed.

GRS provides involved dealers with an updated VIN list of their incomplete vehicles. The owner’s name, address and phone number are listed if known. Completed vehicles are removed from GRS within several days of repair claim submission.

To use this system, click on the “**Service**” tab and then click on “**Global Recall System.**” Your dealer’s VIN list for each recall displayed can be sorted by: those vehicles that were unsold at recall launch, those with a phone number, city, zip code, or VIN sequence.

**Dealers must perform this repair on all unsold vehicles before retail delivery.** Dealers should also use the VIN list to follow up with all owners to schedule appointments for this repair.

*Recall VIN lists may contain confidential, restricted owner name and address information that was obtained from the Department of Motor Vehicles of various states. Use of this information is permitted for this recall only and is strictly prohibited from all other use.*

**ADDITIONAL INFORMATION**

If you have any questions or need assistance in completing this action, please contact your Service and Parts District Manager.

Customer Services / Field Operations  
FCA US LLC.

## Vehicle Preparation

1. Obtain a loaner vehicle for the customer.

**NOTE: Customer's vehicle must not be driven (adding mileage) during cluster ordering process.**

2. Park customer's vehicle and record current vehicle mileage.
3. Order replacement cluster.

**NOTE: Add Recall number 30B to the Customer Complaint field for the exchange order.**

### PARTS INFORMATION

**NOTE: Correct cluster part number to order depends on vehicle's sold status. Sold customer vehicles require a Z8\* part number. Unsold dealer vehicles require a 68\* part number. This will be confirmed at time of order fulfilment.**

Part Number to Order for <b>Sold</b> Vehicles	Part Number to Order for <b>Unsold</b> Vehicles	Part Description	Vehicle	Model Year	Engine Sales Code	Display Sales Codes
Z8614601AE	68614601AE	Instrument Panel Cluster	JL	2024	EC1/ERC	JCB
Z8632937AC	68632937AC	Instrument Panel Cluster	JT	2024	ERC	JCB

4. Once replacement cluster is received, proceed to the Service Procedure.

## SERVICE PROCEDURE

### 2024 Model Year

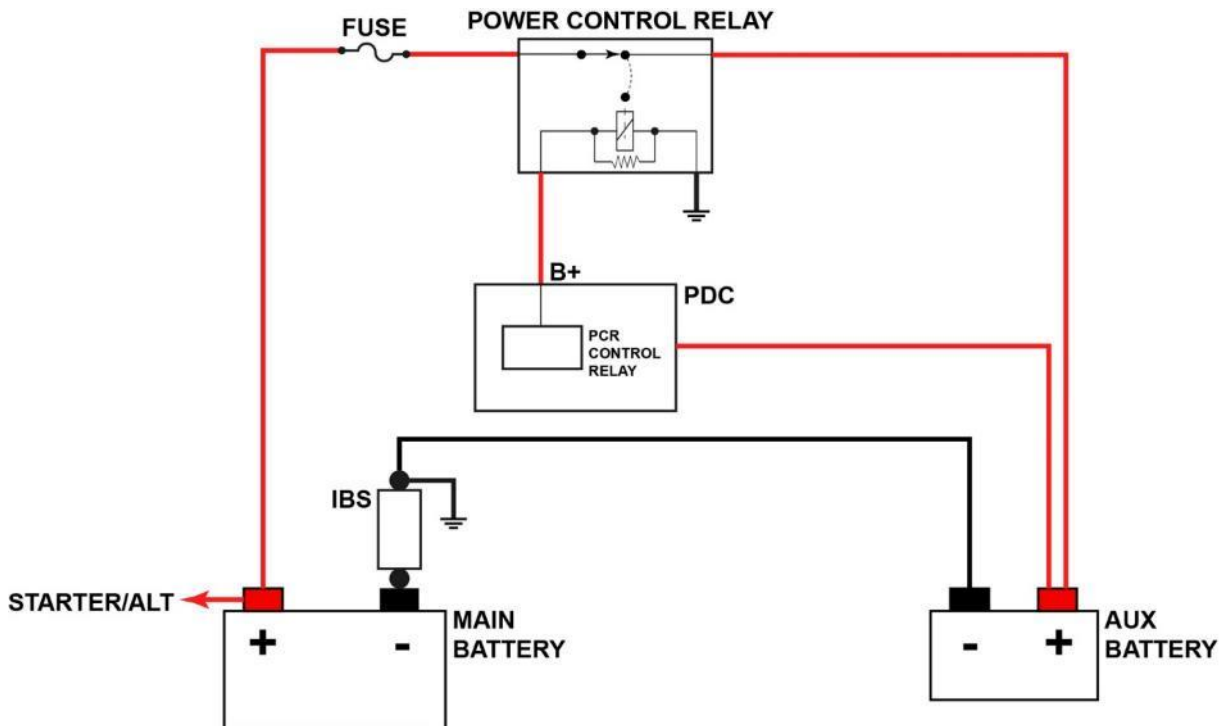

**Figure 9 – Battery System**

**NOTE:** On this dual battery system the auxiliary battery ground cable connects to the main battery cable end (shown in generic graphic above) and grounds through the main battery ground cable connection to the body, chassis, or engine (depending on vehicle). Therefore, simply disconnecting and isolating the main battery negative cable clamp from the main battery post will not isolate the auxiliary from the vehicle's electrical system. The auxiliary battery will still be grounded through its connection to the main battery negative cable end. If both battery negative cables are not isolated, it will result in the vehicle electrical system and Power Distribution Center (PDC) still having battery connection which can cause vehicle wiring damage or deployment of air bags on re-connection. (Figure 9).

1. Open the hood and turn the ignition off. Wait five minutes to allow the main modules to go to sleep.
2. Disconnect and isolate the supplemental (auxiliary) battery negative cable from the main battery negative cable end. This will disconnect and isolate the auxiliary battery ground.
3. The main battery ground can be disconnected by removing the main battery negative cable from the negative battery cable end, or by disconnecting the IBS connector, loosening the negative battery clamp nut and removing the negative battery cable end from the battery post. Either method will disconnect the main battery. Both batteries should be disconnected from the vehicle electrical system.

4. Measure the voltage at the PDC positive battery cable connection to verify the vehicle electrical system is powered down.

**NOTE: On some vehicles a small amount of voltage may be present (typically less than approximately 0.5 volts) due to capacitors in some modules still having voltage stored. Anything less than 1.0 volts should be safe.**

5. Remove both rubber coin trays from the coin tray bezel (Figure 10).



**Figure 10 – Coin Trays**

6. Remove the screws securing the coin tray bezel to instrument panel (Figure 11).

7. Remove the coin tray bezel from instrument panel (Figure 11).



**Figure 11 – Coin Tray Bezel**

**SAFETY RECALL**  
NORTH AMERICA  
**Instrument Panel Cluster**



Reference: 30B / NHTSA 24V-652

FCA US LLC

- 8. From under the coin tray bezel, remove the two screws securing the instrument panel pad (Figure 12).



**Figure 12 – Instrument Panel Pad**

- 9. Use a trim stick or equivalent to release the retaining clips then remove the instrument panel pad (Figure 13).



**Figure 13 – Instrument Panel Pad**

10. Using a trim stick or equivalent, remove the right side instrument panel end cap (Figure 14).



**Figure 14 – Instrument Panel End Cap**

11. Remove four screws securing the grab handle (Figure 15).

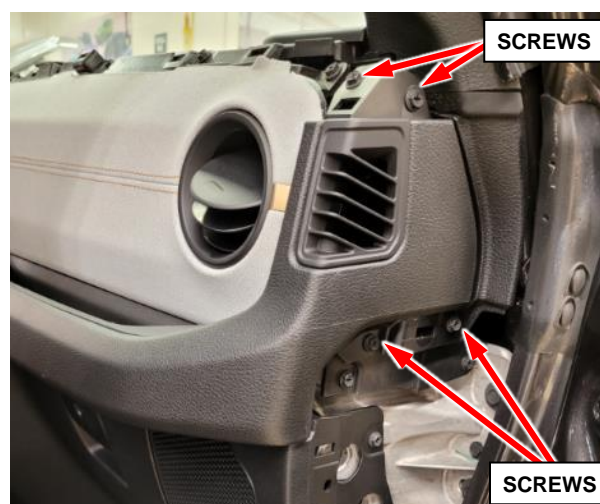

**Figure 15 – Grab Handle Screws**

12. Using a trim stick or equivalent, release the grab handle screw cover (1) from behind passenger grab handle (Figure 16).

13. Remove the three screws (2) securing the grab handle outer bezel (3) to the grab handle bracket (Figure 16).

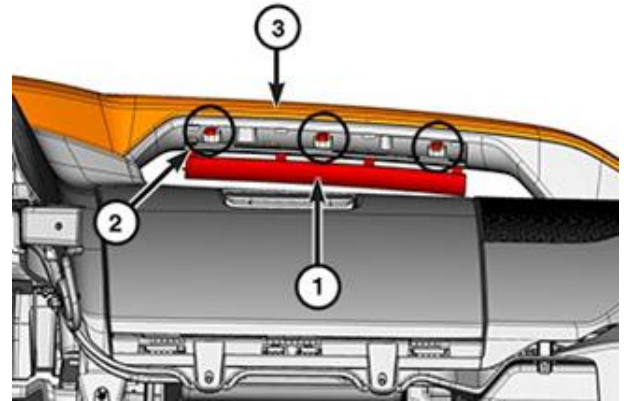

**Figure 16 – Grab Handle Screw Cover**

14. Using a trim stick or equivalent, release the grab handle outer bezel including integrated center stack module from the instrument panel (Figure 17).



**Figure 17 – Grab Handle Outer Bezel**

15. Disconnect the integrated center stack module electrical connector and disconnect the Keyless Ignition Node (KIN) electrical connector (Figure 18).

16. Remove the grab handle outer bezel.

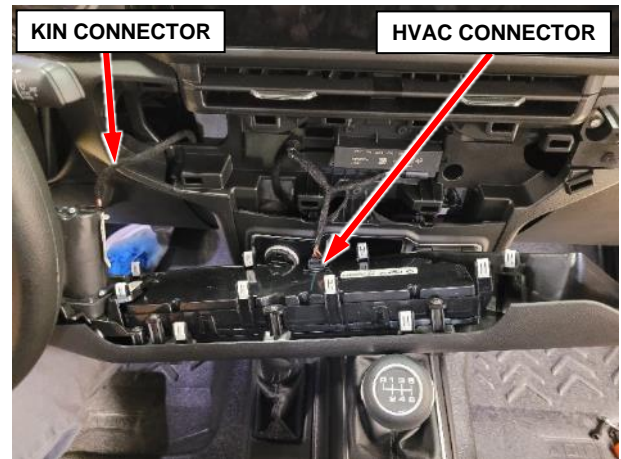

**Figure 18 – Electrical Connectors**

17. Remove the five screws securing the center display screen with instrument cluster bezel to the instrument panel (Figure 19).

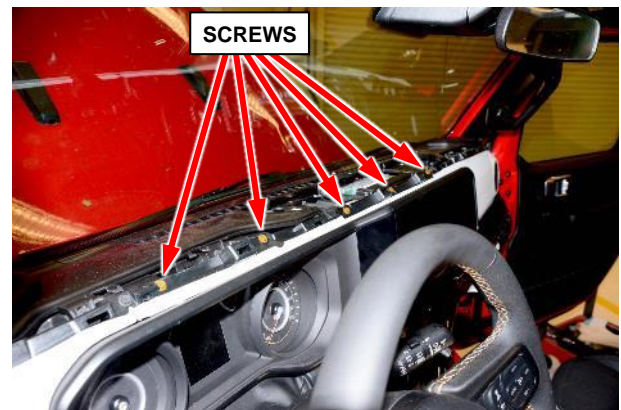

**Figure 19 – Center Display Screen and Instrument Cluster Bezel Screws**

**SAFETY RECALL**  
NORTH AMERICA  
**Instrument Panel Cluster**



Reference: 30B / NHTSA 24V-652

FCA US LLC

- 18. Using a trim stick or equivalent, release the center display screen with instrument cluster bezel from the instrument panel.
- 19. Disconnect the two electrical connectors from the center display screen (Figure 20).

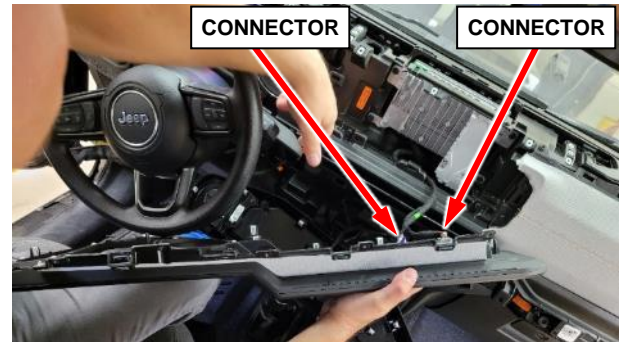

**Figure 20 – Center Display Screen and Instrument Cluster Bezel**

- 20. Remove the screw securing the steering column shroud gap hider (Figure 21).



**Figure 21 – Steering Column Shroud Gap Hider Screw**

# SAFETY RECALL

NORTH AMERICA

## Instrument Panel Cluster



Reference: 30B / NHTSA 24V-652

FCA US LLC

21. Using a trim stick or equivalent, disengage the retaining clips to release the steering column gap hider (1) (Figure 22).

**NOTE:** Gap hider does not need to be fully removed to access the headlamp switch bezel retaining screws.



**Figure 22 – Steering Column Shroud Gap Hider**

22. Using a trim stick or equivalent, remove the left side instrument panel end cap (Figure 23).



**Figure 23 – Instrument Panel End Cap**

# SAFETY RECALL

NORTH AMERICA

## Instrument Panel Cluster



Reference: 30B / NHTSA 24V-652

FCA US LLC

23. Remove the screws (2) securing the headlamp switch bezel (1) to the instrument panel reinforcement (Figure 24).
24. Disconnect the wire harness connector from the headlamp switch and remove the bezel (Figure 24).

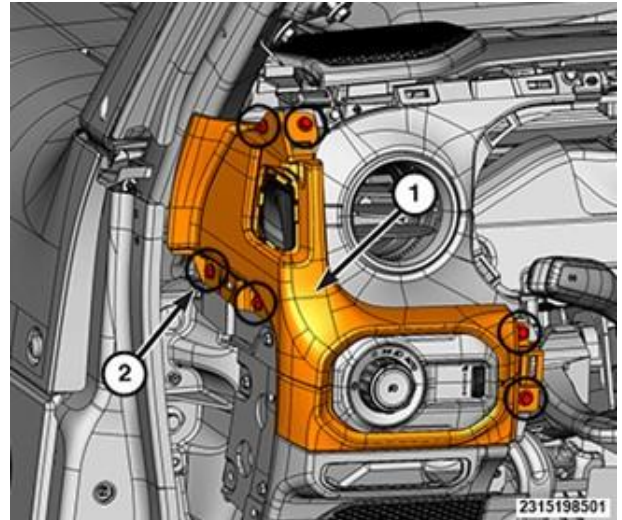

Figure 24 – Headlamp Switch Bezel

25. Remove the fasteners securing the driver front outboard air outlet assembly to the instrument panel, then remove the driver's vent assembly from the vehicle (Figure 25).

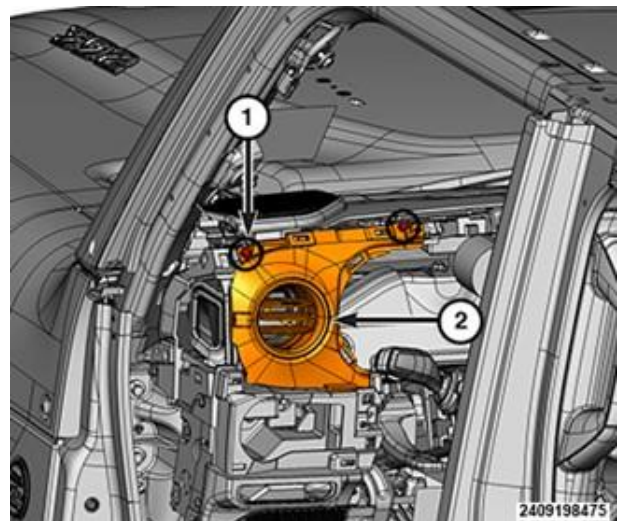

Figure 25 – Driver's Vent Assembly

# SAFETY RECALL

NORTH AMERICA  
Instrument Panel Cluster



Reference: 30B / NHTSA 24V-652

FCA US LLC

26. Remove the four fasteners that secure the Instrument Panel Cluster (IPC) to the instrument panel (Figure 26).



Figure 26 – Instrument Panel Cluster

27. Pull the top of the IPC rearward far enough to access and disconnect the instrument panel wire harness connectors from the back of the IPC (Figure 27).

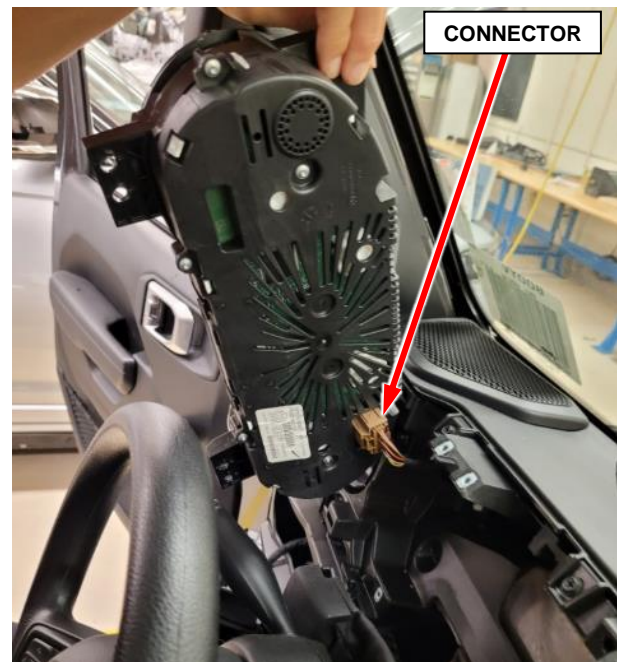

Figure 27 – Instrument Panel Cluster

28. Remove the IPC from the instrument panel.
29. Exchange the IPC for replacement pre-programmed with the correct mileage.
30. Connect the instrument panel wire harness connectors to the back of the **NEW** IPC (Figure 27).
31. Install the **NEW** IPC to the instrument panel and tighten the fasteners securely (Figure 26).
32. Install the driver front outboard air outlet assembly to the instrument panel and tighten the fasteners securely (Figure 25).

33. Connect the wire harness connector to the headlamp switch then install the bezel (1) and tighten the screws (2) securely (Figure 24).

34. Install the left side instrument panel end cap (Figure 23).

35. Engage the retaining clips securing the steering column gap hider (Figure 22).
36. Install and tighten securely the screw securing the steering column gap hider (Figure 21).
37. Connect the two electrical connectors to the center display screen (Figure 20).
38. Install the center display screen with instrument cluster bezel to the instrument panel.
39. Install and tighten securely the five screws securing the center display screen with instrument cluster bezel to the instrument panel (Figure 19).
40. Connect the center stack module electrical connector and connect the Keyless Ignition Node (KIN) electrical connector (Figure 18).
41. Install the grab handle outer bezel to the instrument panel (Figure 17).
42. Install and tighten securely the three screws (2) securing the grab handle outer bezel (3) to the grab handle bracket (Figure 16).
43. Install the grab handle screw cover (1) to back side of passenger grab handle (Figure 16).
44. Install and tighten securely the four screws securing the grab handle (Figure 15).
45. Install the right side instrument panel end cap (Figure 14).
46. Install the instrument panel pad (Figure 13).
47. Install and tighten securely the two screws securing the instrument panel pad (Figure 11).
48. Install the coin tray bezel to the instrument panel (Figure 11).
49. Install and tighten securely the screws securing the coin tray bezel to instrument panel (Figure 11).
50. Install both rubber coin trays to the coin tray bezel (Figure 10).

51. Connect the main battery clamp to the negative post and tighten to 7 N·m (62 In. Lbs.), or connect the main battery negative cable To Intelligent Battery Sensor (IBS) with a nut and tighten to 12 N·m (9 Ft. Lbs.) (Figure 9).
52. Connect the IBS harness connector if disconnected (Figure 9).
53. Connect the auxiliary battery negative cable to the main battery negative cable clamp. If connected by a nut, install the nut and tighten to 5 N·m (44 In. Lbs.) (Figure 9).

**NOTE: Over-tightening of the nuts connecting the negative cables to the IBS may cause damage to the IBS or break the stud.**

54. If available, perform the "ESS 150 Amp Fuse Check" routine from the WiTech tool under guided diagnostics.

**NOTE: Certain indicators in this IPC are automatically configured. This feature allows those indicators to be activated or deactivated for compatibility with certain optional equipment. If a problem is noted that involves improper illumination of an indicator, disconnect and isolate the battery negative cable. After about five minutes, connect the battery negative cable and cycle the ignition to the ON position. The IPC should automatically relearn the equipment in the vehicle and properly configure the indicators.**

55. Using wiTECH, clear any DTCs that may have set during the service procedure.
56. Install the Authorized Modifications Label. Refer to the last page of this document for detailed instructions.
57. Complete Proof of Correction Form for California Residents. Refer to the last page of this document for detailed instructions.
58. Return the vehicle to the customer or inventory.

**Install the Authorized Modifications Label:**

Type or print (with a ballpoint pen) the necessary information shown in (Figure 28) onto the Authorized Modifications Label. Then attach the label near the VECI label.

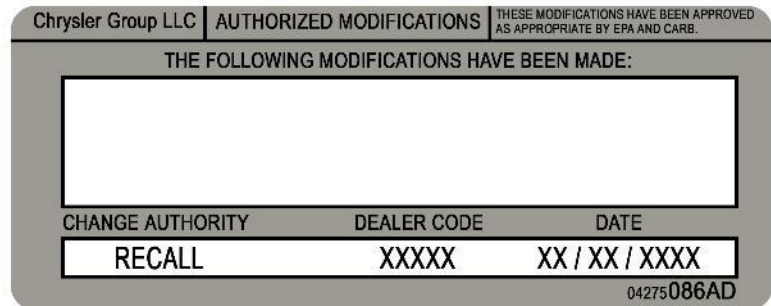

The image shows a rectangular label with a grey border. At the top left, it says "Chrysler Group LLC". To its right, in a larger font, is "AUTHORIZED MODIFICATIONS". Further right, in a smaller font, is "THESE MODIFICATIONS HAVE BEEN APPROVED AS APPROPRIATE BY EPA AND CARB.". Below this header, it says "THE FOLLOWING MODIFICATIONS HAVE BEEN MADE:" followed by a large empty rectangular box. Below the box is a table with three columns: "CHANGE AUTHORITY", "DEALER CODE", and "DATE". The first row of the table contains the text "RECALL", "XXXXX", and "XX / XX / XXXX". At the bottom right of the label, the number "04275086AD" is printed.

CHANGE AUTHORITY	DEALER CODE	DATE
RECALL	XXXXX	XX / XX / XXXX

**Figure 28 – Authorized Modifications Label**

**Complete Proof of Correction Form for California Residents:**

This recall is subject to the **State of California Registration Renewal/Emissions Recall Enforcement Program**. Complete a Vehicle Emission Recall Proof of Correction Form (**Form No. 81-016-1053**) and **supply it to vehicle owners residing in the state of California** for proof that this recall has been performed when they renew the vehicle registration.

Process Steps to obtain the California Proof of Correction form:

- a. Access the "DealerCONNECT" website.
- b. Select the "Service" tab.
- c. Under the "Publications" heading, select the "ePublishing" link.
- d. Sign in using your Dealer Code and Password.
- e. Select the "Proof of Correction form".

This notice applies to your vehicle.

[Model Year and Model]

VIN XXXXXXXXXXXXXXXXXXXX

30B/NHTSA 24V-652

LOGO

VEHICLE PICTURE

#### YOUR SCHEDULING OPTIONS

##### 1. **RECOMMENDED OPTION**

Call your authorized Chrysler / Dodge / Jeep® / RAM Dealership.

##### 2. Call the FCA Recall Assistance

Center at **1-800-853-1403**. An agent can confirm part availability and help schedule an appointment.

##### 3. Visit [recalls.mopar.com](https://recalls.mopar.com), scan the

QR code below, or download the Mopar Owner's Companion App.

QR Code

Get access to recall notifications, locate your nearest dealer, and more through this website or Mopar Owner's Companion App. You will be asked to provide your Vehicle Identification Number (VIN) to protect and verify your identity. The last eight characters of your VIN are provided above.

#### DEALERSHIP INSTRUCTIONS

Please reference Safety Recall 30B.

# IMPORTANT SAFETY RECALL

## Instrument Panel Cluster

Dear [Name],

This notice is sent to you in accordance with the National Traffic and Motor Vehicle Safety Act.

FCA US LLC has decided that certain [2024 model year (JL) Jeep® Wrangler and 2024 model year (JT) Jeep® Gladiator] vehicles equipped with a 3.5" Instrument Panel Cluster (IPC) fail to conform to Federal Motor Vehicle Safety Standard (FMVSS) No. 101 - Controls and displays.

It is extremely important to take steps now to repair your vehicle to ensure the safety of you and your passengers.

#### WHY DOES MY VEHICLE NEED REPAIRS?

The IPC on your vehicle <sup>[1]</sup> may become blank. **An IPC that fails to display critical safety information, such as the speedometer or warning lights can cause a vehicle crash without prior warning.**

The condition described above does not comply with Federal Motor Vehicle Safety Standard (FMVSS) No. 571.101, Controls and Displays S5.3 requires vehicles to "illuminate telltales and their identification sufficiently to make them visible to the driver under daylight and nighttime driving conditions." The IPC in the suspect vehicles may not illuminate the required telltales.

#### HOW DO I RESOLVE THIS IMPORTANT SAFETY ISSUE?

FCA US LLC will repair your vehicle <sup>[2]</sup> free of charge (parts and labor). To do this, your dealer will replace the IPC. **The estimated repair time is 2 days** for the new IPC to be programmed with the current mileage and delivered to the dealership. The vehicle must remain parked at the dealership during that time. Ask your dealer for alternate transportation options while your vehicle is in service. Your time is important to us, so we recommend that you schedule a service appointment to minimize your inconvenience. Please bring this letter with you to your dealership.

**TO SCHEDULE YOUR FREE REPAIR,  
CALL YOUR CHRYSLER, DODGE, JEEP OR RAM DEALER TODAY**

#### CALIFORNIA RESIDENTS

The State of California requires the completion of emission recall repairs prior to vehicle registration renewal. Your dealer will provide you with a Vehicle Emission Recall Proof of Correction Form after the Safety Recall service is performed. Be sure to save this form since the California Department of Motor Vehicles may require that you supply it as proof that the Safety Recall has been performed.

In order to ensure your full protection under the emissions warranty provisions, it is recommended that you have your vehicle serviced as soon as possible. Failure to do so could be determined as lack of proper maintenance of your vehicle.

#### WHAT IF I ALREADY PAID TO HAVE THIS REPAIR COMPLETED?

If you have already experienced this specific condition and have paid to have it repaired, you may visit [www.fcarecallreimbursement.com](https://www.fcarecallreimbursement.com) to submit your reimbursement request online. <sup>[3]</sup> Once we receive and verify the required documents, reimbursement will be sent to you within 60 days. If you have had previous repairs performed and/or already received reimbursement, you may still need to have the recall repair performed.

We apologize for any inconvenience, but are sincerely concerned about your safety. Thank you for your attention to this important matter.

Customer Assistance/Field Operations  
FCA US LLC



**Mr. Mrs. Customer**  
**1234 Main Street**  
**Hometown, MI 48371**

[1] If you no longer own this vehicle, please help us update our records. Call the FCA Recall Assistance Center at 1-800-853-1403 to update your information.

[2] If your dealer fails or is unable to remedy this defect without charge and within a reasonable time, you may submit a written complaint to the Administrator, National Highway Traffic Safety Administration, 1200 New Jersey Ave., S.E., Washington, DC 20590, or you can call the toll-free Vehicle Safety Hotline at 1-888-327-4236 (TTY 1-800-424-9153), or go to [safercar.gov](http://safercar.gov).

[3] You can also mail in your original receipts and proof of payment to the following address for reimbursement consideration: FCA Customer Assistance, P.O. Box 21-8004, Auburn Hills, MI 48321-8007, Attention: Recall Reimbursement.

Note to lessors receiving this recall notice: Federal regulation requires that you forward this recall notice to the lessee within 10 days.

This notice applies to your vehicle,

[Model Year and Model]

VIN XXXXXXXXXXXXXXXXXXXX

30B/NHTSA 24V-652

LOGO

VEHICLE PICTURE

#### YOUR SCHEDULING OPTIONS

1. Visit [recalls.mopar.com](https://recalls.mopar.com) to sign up for email or SMS notifications for when remedy parts become available. You will be asked to provide your Vehicle Identification Number (VIN), provided above
2. Scan below using your smartphone or tablet to sign up to be notified when remedy parts become available
3. Wait for FCA US to contact you again, by mail, with a follow-up recall notice when remedy parts are available
4. Call the FCA Recall Assistance Center at 1-800-853-1403. An agent can sign you up to be notified when remedy parts become available, or answer any other questions you may have

QR Code

# IMPORTANT SAFETY RECALL

## Instrument Panel Cluster

Dear [Name],

This notice is sent to you in accordance with the National Traffic and Motor Vehicle Safety Act.

FCA US LLC, has decided that certain [2022 through 2023 model year (JL) Jeep® Wrangler and (JT) Jeep® Gladiator] vehicles equipped with a 3.5" Instrument Panel Cluster (IPC) fail to conform to Federal Motor Vehicle Safety Standard (FMVSS) No. 101 - Controls and displays.

#### WHY DOES MY VEHICLE NEED REPAIRS?

The IPC on your vehicle <sup>[1]</sup> may become blank. **An IPC that fails to display critical safety information, such as the speedometer or warning lights can cause a vehicle crash without prior warning.**

The condition described above does not comply with Federal Motor Vehicle Safety Standard (FMVSS) No. 571.101, Controls and Displays S5.3 requires vehicles to "illuminate telltales and their identification sufficiently to make them visible to the driver under daylight and nighttime driving conditions." The IPC in the suspect vehicles may not illuminate the required telltales.

#### HOW DO I RESOLVE THIS IMPORTANT SAFETY ISSUE?

**The remedy for this condition is not currently available.** We are making every effort to finalize the remedy, and will service your vehicle free of charge (parts and labor) when the remedy is available.

FCA US will contact you again, by mail, with a follow-up recall notice when the remedy is available. Once you receive your follow-up notice, simply contact your Chrysler, Jeep®, Dodge or RAM dealer right away to schedule a service appointment <sup>[2]</sup>. Additional options for your next steps are included on the left side of this notification. We appreciate your patience.

#### WHAT IF I ALREADY PAID TO HAVE THIS REPAIR COMPLETED?

If you have already experienced this specific condition and have paid to have it repaired, you may visit [www.fcarecallreimbursement.com](https://www.fcarecallreimbursement.com) to submit your reimbursement request online <sup>[3]</sup>. Once we receive and verify the required documents, reimbursement will be sent to you within 60 days. If you have had previous repairs performed and/or already received reimbursement, you may still need to have the recall repair performed.

We apologize for any inconvenience, but are sincerely concerned about your safety. Thank you for your attention to this important matter.

Customer Assistance/Field Operations  
FCA US LLC

#### DEALERSHIP INSTRUCTIONS

Please reference Safety Recall 30B.



**Mr. Mrs. Customer**  
**1234 Main Street**  
**Hometown, MI 48371**

[1] If you no longer own this vehicle, please help us update our records. Call the FCA Recall Assistance Center at 1-800-853-1403 to update your information.

[2] If your dealer fails or is unable to remedy this defect without charge and within a reasonable time, you may submit a written complaint to the Administrator, National Highway Traffic Safety Administration, 1200 New Jersey Ave., S.E., Washington, DC 20590, or you can call the toll-free Vehicle Safety Hotline at 1-888-327-4236 (TTY 1-800-424-9153), or go to [safercar.gov](http://safercar.gov).

[3] You can also mail in your original receipts and proof of payment to the following address for reimbursement consideration: FCA Customer Assistance, P.O. Box 21-8004, Auburn Hills, MI 48321-8007, Attention: Recall Reimbursement.

Note to lessors receiving this recall notice: Federal regulation requires that you forward this recall notice to the lessee within 10 days.