



Safety Recall

Code: 57J9

Subject Door Handles

Document History

Date	Summary
01/22/2025	Updated parts and claiming information to include additional part number options Updated work instructions: door handle part numbers starting with 11K will not require modification of the cover.
01/14/2025	Updated document upload location in claiming instructions for Canadian dealers Updated button trim removal caution in sections B and C Added example of broken window switch to sections B and C
12/19/2024	Original publication

Affected Vehicles

Country	Beginning Model Year	Ending Model Year	Vehicle	Vehicle Count
USA	2021	2024	ID.4	99,064
CAN	2021	2024	ID.4	20,790

Check Campaigns/Actions screen in ELSA on the day of repair to verify that a VIN qualifies for repair under this action. ELSA is the only valid campaign inquiry & verification source.

- ✓ Campaign status must show "open."
- ✓ If ELSA shows other open action(s), inform your customer so that the work can also be completed at the same time the vehicle is in the workshop for this campaign.

Problem Description

The affected vehicles may have been built with door handles that do not meet the factory specifications for protection against water entry. Water entry into the printed circuit board can lead to malfunctions causing an "open command" to the door lock. An open door on a moving vehicle increases the risk of injury.

Corrective Action

Inspect and replace the affected door handles.

Precautions

If the recall condition is present in the vehicle, occupants may notice an audible clicking noise (similar to the sound of a vehicle door being locked/unlocked). Should this occur, customers are advised to contact an authorized Volkswagen dealer without delay to have the vehicle inspected.

Code Visibility

On September 06, 2024, the campaign code was applied to affected vehicles.

Owner Notification

Owner notification took place in December 2024. Owner letter examples are included in this bulletin for your reference.

Additional Information

Please alert everyone in your dealership about this action, including Sales, Service, Parts and Accounting personnel. Contact Warranty if you have any questions.

IMPORTANT REMINDER ON VEHICLES AFFECTED BY SAFETY & COMPLIANCE RECALL

New Vehicles in Dealer Inventory: It is a violation of federal law for a dealer to deliver a new motor vehicle or any new or used item of motor vehicle equipment (including a tire) covered by this notification under a sale or lease until the defect or noncompliance is remedied. By law, dealers must correct, prior to delivery for sale or lease, any vehicle that fails to comply with an applicable Federal Motor Vehicle Safety Standard or that contains a defect relating to motor vehicle safety.

Pre-Owned Vehicles in Dealer Inventory: Dealers should not deliver any pre-owned vehicles in their inventory which are involved in a safety or compliance recall until the defect has been remedied.

Dealers must ensure that every affected inventory vehicle has this campaign completed before delivery to consumers.

Fill out and affix Campaign Completion Label (CAMP 010 000) after work is complete. *Labels can be ordered at no cost via the Compliance Label Ordering portal at www.vwhub.com.*

Parts Information

Criteria	Quantity	Part Number	P.O.C. Part Description	Ordering Method
ALL	1	11A-837-857-H or 11K-867-919-D	HANDLE (LF)	Reference POC comments individually by part number, or in the POC Campaign List.
	1	11A-837-858-H or 11K-867-920-D	HANDLE (RF)	
	1	11A-837-857-G or 11K-867-919-E	HANDLE (LR)	
	1	11A-837-858-G or 11K-867-920-E	HANDLE (RR)	

NOTE: Ideally, each vehicle will have four "11A" or four "11K" parts installed. If this is not possible, it is ok to use a mix of part numbers.

Initial Allocation:
YES

Dealers will be sent an initial allocation prior to customer notification. If no initial allocation was received, please reference your dealer's Estimated Remaining Repairs by campaign to view your potential VIN population.

NOTE

Your dealer's Estimated Remaining Repairs by campaign can be found in Parts on Command. Click on "View Campaign List" and review the Estimated Remaining Repairs column.

NOTE

Campaign parts should always be ordered as per the parts information in this circular. The ordering system will supersede the part, if applicable.

Claim Entry Instructions

The labor times listed here may differ from the labor operations and labor times listed in ELSA.

After campaign has been completed, enter claim as soon as possible to help prevent work from being duplicated elsewhere. Attach the ELSA screen print showing action open on the day of repair to the repair order.

If a customer declines campaign work, refer to the "Customer Declines Campaign/Update Repair" section in the Campaign/Update Policy and Procedures Manual.

Service Number	57J9
Damage Code	0099
Parts Vendor Code	WWO
Claim Type	Sold vehicle: 7 10 Unsold vehicle: 7 90
Causal Indicator	Mark any HANDLE* as causal part
Vehicle Wash/Loaner	Do not claim wash/loaner under this action. Loaner/rental coverage cannot be claimed under this action. However, loaner/rental may be covered under the current loaner/mobility program. Please refer to the Volkswagen Warranty Policy and Procedures Manual for loaner claims information and reimbursement details.

**Vehicles may have more than one criteria.
Complete and claim all applicable criteria on one claim.**

Overview of criteria:

Criteria	Description of work
02	Replace all four door handles and modify door handle covers.
03	Replace all four door handles.
01 and 02	Replace all four door handles, modify door handle covers and perform software update.
01 and 03	Replace all four door handles and perform software update.

Continued on next page

LABOR			
Criteria	Labor Op	Time Units	Description
02 or 03	5711 55 99	340	Replace four door handles
02	5711 49 99	5 TU per door handle	Modify door handle cover(s) <i>(modification required only for door handle part numbers starting with 11A)</i>
01	2706 89 50	SEE ELSA	Connect battery charger
	0150 00 60	Time stated on diagnostic protocol	GFF/Guided Functions <i>(software update)</i>
	0121 00 04	10	Test drive

PARTS			
Criteria	Quantity	Part Number	Description
ALL	1.00	11A837857H or 11K867919D	HANDLE (LF)
	1.00	11A837858H or 11K867920D	HANDLE (RF)
	1.00	11A837857G or 11K867919E	HANDLE (LR)
	1.00	11A837858G or 11K867920E	HANDLE (RR)

AND (ONLY if necessary)	Add the following as needed only if the interior door handle trim was damaged during door handle replacement, or if door panel clips were damaged, or if door handle gasket required replacement.		
	PARTS		
	Quantity	Part Number	Description
	As required	SEE ETKA	Interior door handle trim
	As required	SEE ETKA	Door handle gasket
As required	SEE ETKA	Interior door handle clips	

Continued on next page

AND (ONLY if necessary)	Add the following as needed only if the exterior door handle cover was damaged during door handle replacement.			
	PARTS			
	Quantity	Part Number	Description	
	1.00	11A837149 GRU	COVER (LF)	
	1.00	11A837150A GRU	COVER (RF)	
	1.00	11A837149C GRU	COVER (LR)	
	1.00	11A837150C GRU	COVER (RR)	
	1.00	11A837879D GRU	COVER (lock cylinder)	
	OUTSIDE MATERIAL			
	Quantity	Part Number	Description	Amount
	1	PAINTCOVER (enter part number in all caps)	Paint material and labor needed to paint door handle cover	Total amount of paint material and labor from body shop invoice
<p><i>NOTE: US Dealers - The body shop invoice must be uploaded to Doc-IT. Canadian Dealers - Create a WIN ticket and upload the body shop invoice.</i></p>				

Customer Letter Example (USA)

<MONTH YEAR>

<CUSTOMER NAME>

<CUSTOMER ADDRESS>

<CUSTOMER CITY STATE ZIPCODE>

This notice applies to your vehicle: <MODEL YEAR> <BRAND> <CARLINE>, <VIN>

NHTSA: 24V651

Subject: Safety Recall 57J9 -Door Handles

Dear Volkswagen Owner,

This notice is sent to you in accordance with the National Traffic and Motor Vehicle Safety Act. Volkswagen has decided that a defect, which relates to motor vehicle safety, exists in certain 2021-2024 model year Volkswagen vehicles. Our records show that you are the owner of a vehicle affected by this action.

What is the issue?

The affected vehicles may have been built with door handles that do not meet the factory specifications for protection against water entry. Water entry into the printed circuit board can lead to malfunctions causing an "open command" to the door lock. An open door on a moving vehicle increases the risk of injury.

What will we do?

To correct this defect, your authorized Volkswagen dealer will inspect and, if necessary, replace the affected door handles. This work will take about four hours to complete and will be performed for you free of charge. Please keep in mind that your dealer may need additional time for the preparation of the work, as well as to accommodate their daily workshop schedule.

What should you do?

Please contact your authorized Volkswagen dealer without delay to schedule this recall work. To set up an appointment online, please visit www.vw.com/find-a-dealer.

Precautions you should take:

If the recall condition is present in the vehicle, occupants may notice an audible clicking noise (similar to the sound of a vehicle door being locked/unlocked). Should this occur, customers are advised to contact an authorized Volkswagen dealer without delay to have the vehicle inspected.

Additional Information

- If you are the lessor and registered owner of the vehicle identified in this action, the law requires you to forward this letter immediately via first-class mail to the lessee within ten (10) days of receipt.
- If your authorized Volkswagen dealer fails or is unable to complete this work free of charge within a reasonable time, if you have changed your address or no longer own the vehicle identified in this letter, or if you should have any questions about this communication, please reach out to us using your preferred method of communication at www.vw.com/contact or by calling us at 800-893-5298.
- If you still cannot obtain satisfaction, you may file a complaint with: The Administrator, National Highway Traffic Safety Administration, 1200 New Jersey Avenue, SE., Washington, DC 20590; or call the toll-free Vehicle Safety Hotline at 1-888-327-4236 (TTY: 1-800-424-9153); or go to <http://www.safercar.gov>.
- To check your vehicle's eligibility for repair under this or any other recall/service campaign, please visit www.vw.com/owners/recalls and enter your Vehicle Identification Number (VIN) into the Recall/Service Campaign Lookup tool.
- If you have previously paid for repairs relating to the condition described in this letter, the enclosed form explains how to request reimbursement. We would be pleased to review your reimbursement request.

We apologize for any inconvenience this matter may cause; however, we are taking this action to help ensure your safety and continued satisfaction with your vehicle.

Sincerely,

Volkswagen Customer Protection

Customer Customer Letter Example (Canada)

<MONTH YEAR>

<CUSTOMER NAME>

<CUSTOMER ADDRESS>

<CUSTOMER CITY STATE ZIPCODE>

This notice applies to your vehicle: <MODEL YEAR> <BRAND> <CARLINE>, <VIN>

Transport Canada Recall: 2024-502

Subject: Safety Recall 57J9 -Door Handles

Dear Volkswagen Owner,

This notice is sent to you in accordance with the requirements of the *Motor Vehicle Safety Act*. This is to inform you that your vehicle may contain a defect that could affect the safety of a person. Our records show that you are the owner of a vehicle affected by this action.

What is the issue?

The affected vehicles may have been built with door handles that do not meet the factory specifications for protection against water entry. Water entry into the printed circuit board can lead to malfunctions causing an "open command" to the door lock. An open door on a moving vehicle increases the risk of injury.

What will we do?

To correct this defect, your authorized Volkswagen dealer will inspect and, if necessary, replace the affected door handles. This work will take about four hours to complete and will be performed for you free of charge. Please keep in mind that your dealer may need additional time for the preparation of the work, as well as to accommodate their daily workshop schedule.

What should you do?

Please contact your authorized Volkswagen dealer without delay to schedule this recall work.

Precautions you should take:

If the recall condition is present in the vehicle, occupants may notice an audible clicking noise (similar to the sound of a vehicle door being locked/unlocked). Should this occur, customers are advised to contact an authorized Volkswagen dealer without delay to have the vehicle inspected.

Additional Information

- If you are the lessor and registered owner of the vehicle identified in this letter, you shall forward this letter (and any subsequent notice, if applicable) to the lessee within ten (10) days of receipt.
- If your authorized Volkswagen dealer fails or is unable to complete this work free of charge within a reasonable time, if you have changed your address or no longer own the vehicle identified in this letter, or if you should have any questions about this communication, please contact Customer Relations, Monday through Friday from 8AM to 8PM EST by phone at 1-800-822-8987 or via our "Contact Us" page at www.vw.ca.
- If you have previously paid for repairs relating to the condition described in this letter, the enclosed form explains how to request reimbursement. We would be pleased to review your reimbursement request.

We apologize for any inconvenience this matter may cause; however, we are taking this action to help ensure your safety and continued satisfaction with your vehicle.

Sincerely,

Volkswagen Customer Protection

Repair Overview

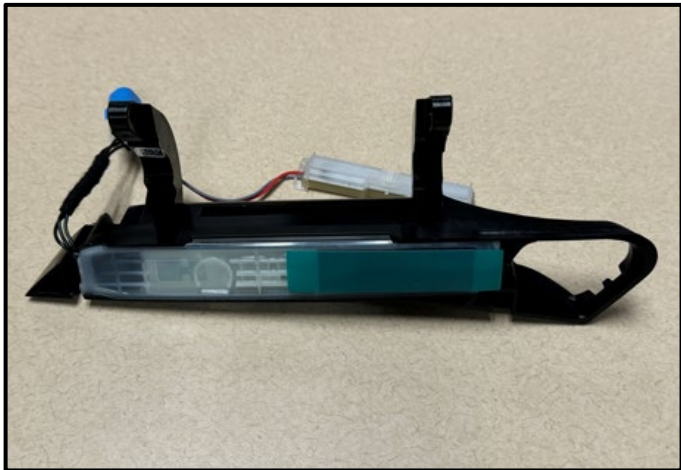

Vehicles assigned only criteria 02 or 03:

- Replace door handle on all four doors.

Vehicles assigned criteria 02 or 03, AND 01:

- Replace door handle on all four doors.
- Update door control module software (criteria 01 is assigned to vehicles requiring a software update).

! NOTE

- These repair instructions may differ from the labor operations and labor times listed in ELSA.
- Damages resulting from improper repair or failure to follow these work instructions are the dealer's responsibility and are not eligible for reimbursement under this action.
- This procedure must be read in its entirety prior to performing the repair.
- Due to variations in vehicle equipment and options, the steps/illustrations in this work procedure may not identically match all affected vehicles.
- Diagnosis and repair of pre-existing conditions in the vehicle are not covered under this action.
- When working during extreme temperatures, it is recommended that the vehicle be allowed to acclimate inside the shop to avoid temperature-related component damage/breakage.

Required Tools



 <p>Wedge Set -T10383- (or equivalent)</p>	 <p>Elbow Assembly Tool -T10118- (or equivalent)</p>
 <p>Release Tool -T10615-</p>	 <p>Diagnostic Tester -VAS6150X/VAS6160X- (or equivalent)</p>
 <p>Battery Tester/Charger -VAS5908- (or equivalent charger with a current rating of at least 70A)</p>	 <p>Face Shield/Eye Protection (if necessary) (locally sourced)</p>
 <p>Rotary tool (if necessary) (locally sourced)</p>	 <p>Carbide Burr Grinder Bits (if necessary) (locally sourced)</p>

Repair Instruction

Section A - Check for Previous Repair

TIP

If Campaign Completion label is present, no further work is required.

Applicable criteria ID(s)	Campaign/Action Status
01 	Open 

EXAMPLE

Campaign/Action	Start	Designation
	2015-11-10	W-SERV_ACT -
	2018-12-13	RECALL -
	2017-05-16	A-RECALL -

EXAMPLE

- Enter the VIN in Elsa and proceed to the “Campaign/Action” screen.

TIP

On the date of repair, print this screen and keep a copy with the repair order.

- Confirm the Campaign/Action is open <arrow 1>. If the status is closed, no further work is required.
- Note the Applicable Criteria ID <arrow 2> for use in determining the correct work to be done and corresponding parts associated.

CRITICAL REPAIR STEP



All campaigns/actions with a repair available must be performed in order of the Start date <arrow 3>. The oldest should be performed first (unless otherwise noted in the repair instructions).

Proceed to Section B

CRITICAL REPAIR STEP



If Compliance Recall 919A is also open, **DO NOT PERFORM THE 919A SOFTWARE UPDATE WHILE REPLACING THE DOOR HANDLES UNDER THE 57J9**. Doing so could result in failure of the 919A software update.

Section B – Front Door Handle Assembly Removal and Installation

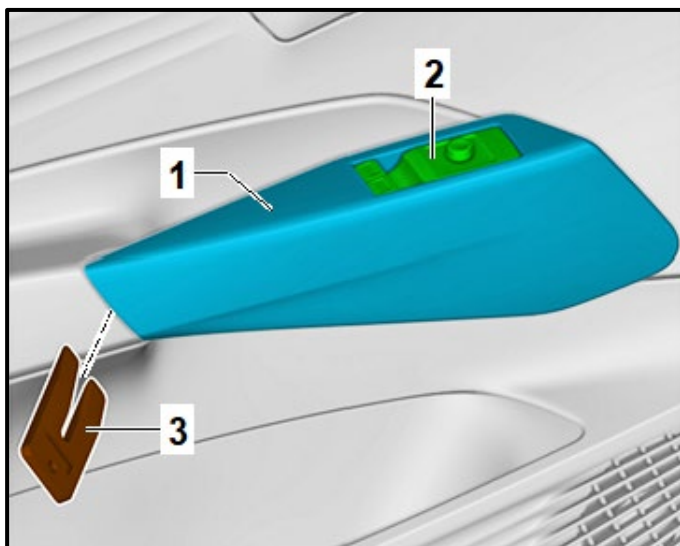

Remove button trim:

- Unclip the button trim <1> with controls <2> using the Wedge -T10383- <3>.
- Disconnect the connectors.
- Replace the button trim if damaged.



⚠ CAUTION

Risk of consequential damage!

When removing the button trim, it can release suddenly resulting in damage to the window switch. Use extreme care when removing the button trim.

- After the rear section of the button trim is loose, rotate the wedge in the direction indicated <red arrow> while carefully pulling the trim in the direction indicated <green arrow>.
- Driver's rear door shown. Procedure for all doors is similar.

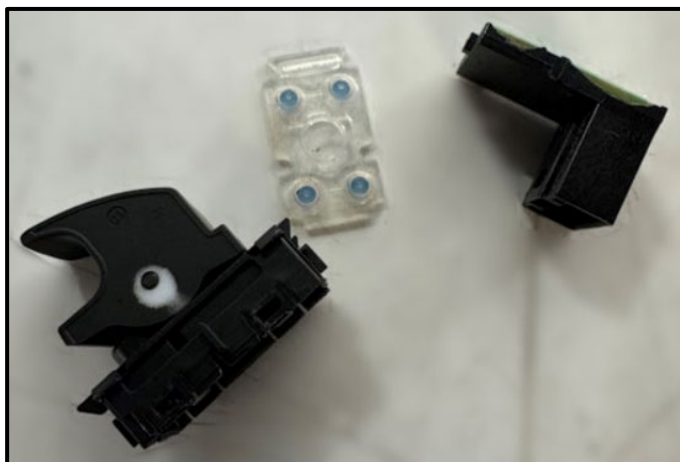

ⓘ NOTE

The switch shown is an example of the damage that can occur to the window switch if the button trim suddenly releases during removal.

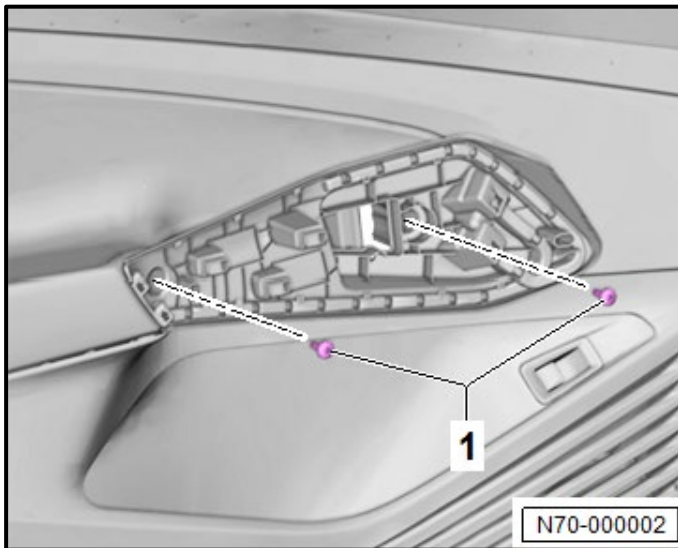

Remove door panel:

- Remove the bolts <1>.

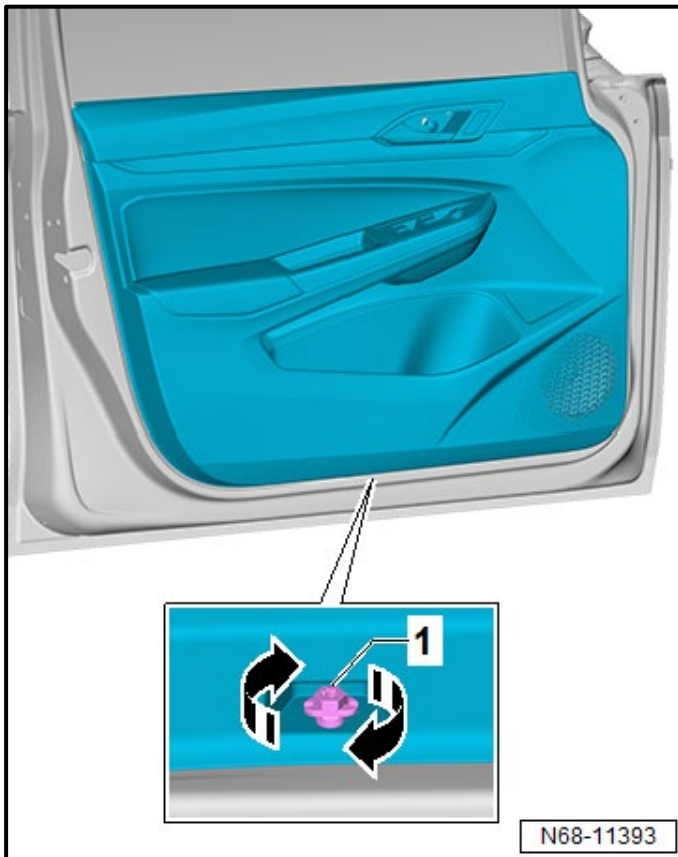

- Turn the rotating clip <1> 90° in the direction of <arrow> and release it.

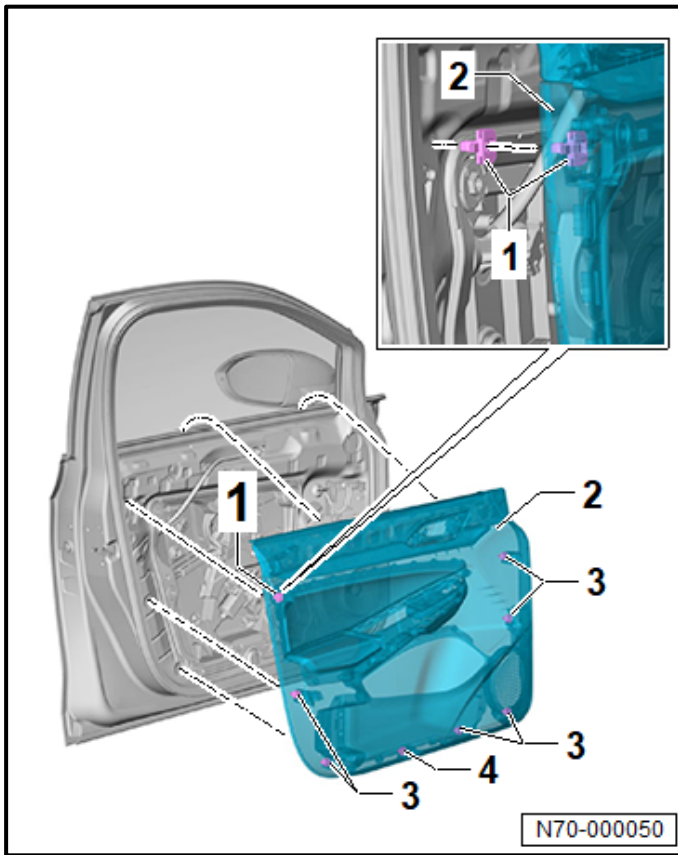

⚠ CAUTION

Risk of consequential damage!
 There is a risk of damaging the release cable by deforming it. Do not bend or kink the release cable.

- Loosen the clips <3> in the front door trim panel <2> using a Wedge -T10383-.
- Pull the front door trim panel <2> upward out of the inner window shaft strip.
- Disconnect any connectors present on the door panel.

i TIP

The upper left crash clip <1> is automatically released from the inner window shaft strip when the front door trim panel <2> is lifted out.

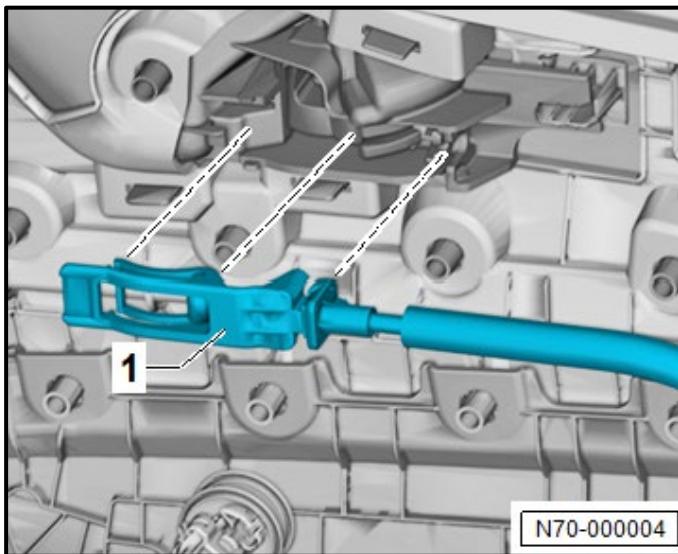

- Disengage the release cable <1>.
- Set the door panel off to the side.

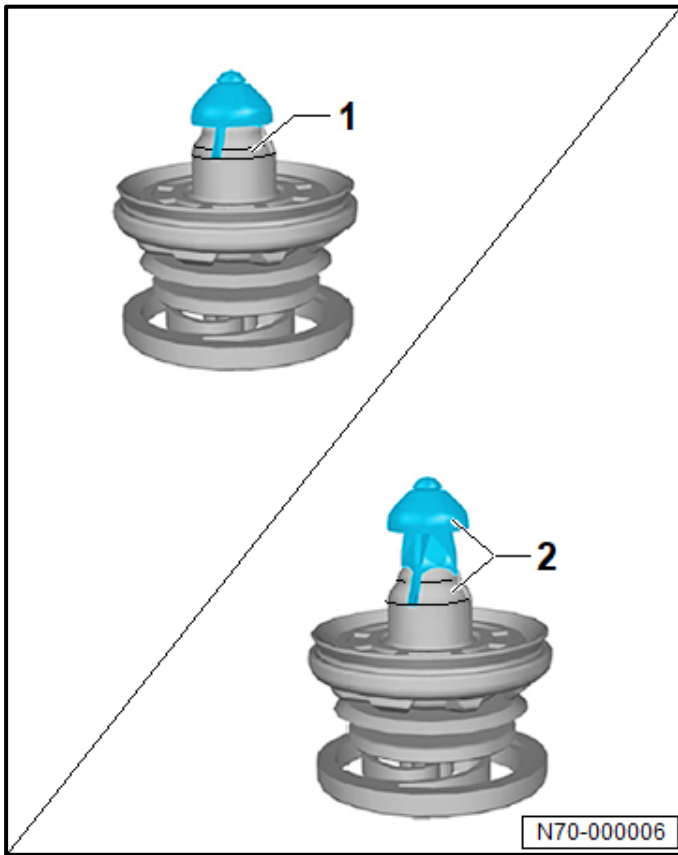

⚠ CAUTION

- Risk of damaging the locking mechanism.**
- Always turn the locking mechanism from position <2> to position <1>.
 - The door trim panel can only be installed when the locking mechanism is in position <1>.

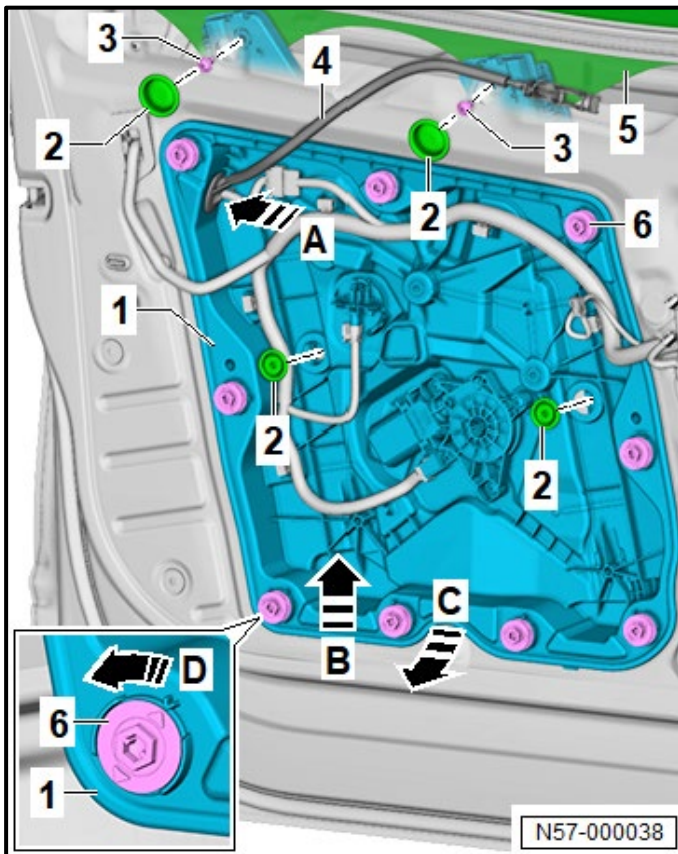

- Remove support for door components:**
- Pry off/remove the caps/adhesive tape <2> from the support <1> using a commercially available plastic wedge.

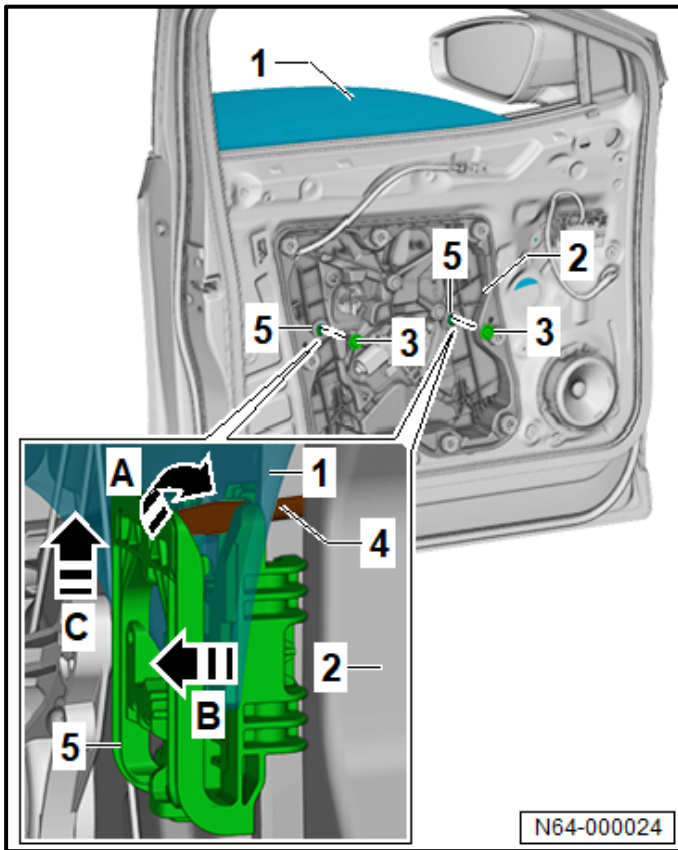

- Reconnect window switch temporarily.
- Lower the front door window <1> until the clamping brackets on the sub-frame <5> are accessible through the opening in the sub-frame <2>.
- Guide a suitable screwdriver <4> through the openings in the sub-frame <2> and the front door window <1> toward the sub-frame clamping bracket <5>.
- Turn the screwdriver <4> 90° in the direction of <arrow A> and press in the direction of the <arrow B> in the hook on the sub-frame clamping brackets <5> until they disengage.
- Slightly lift the front door window <1> in the direction of <arrow C> so that it does not fall back into the hook.

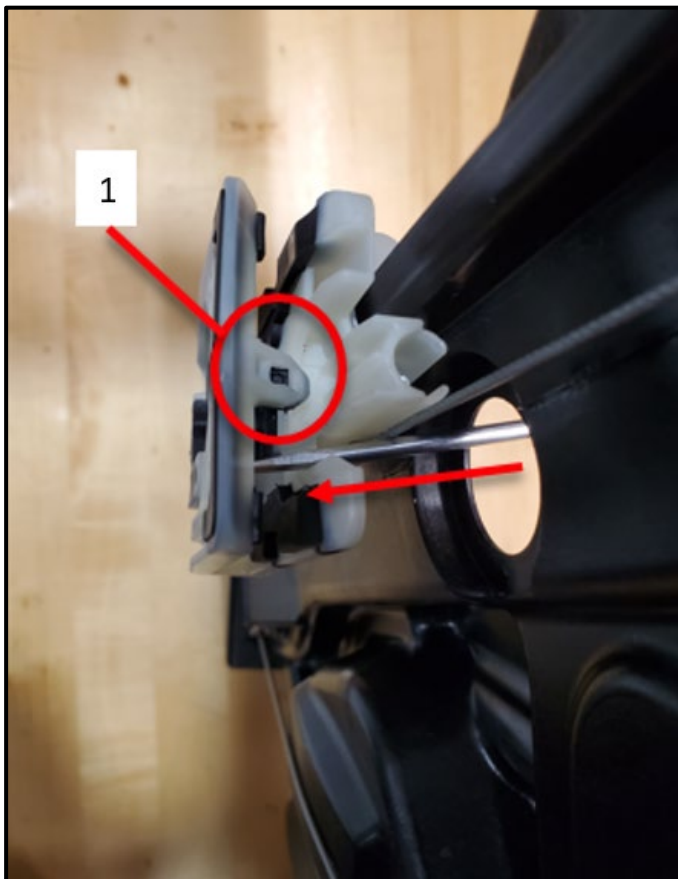

- Clamping bracket <1> shown with sub-frame removed. Screwdriver pressed in the direction indicated <arrow> to disengage the clamp from the window glass panel.

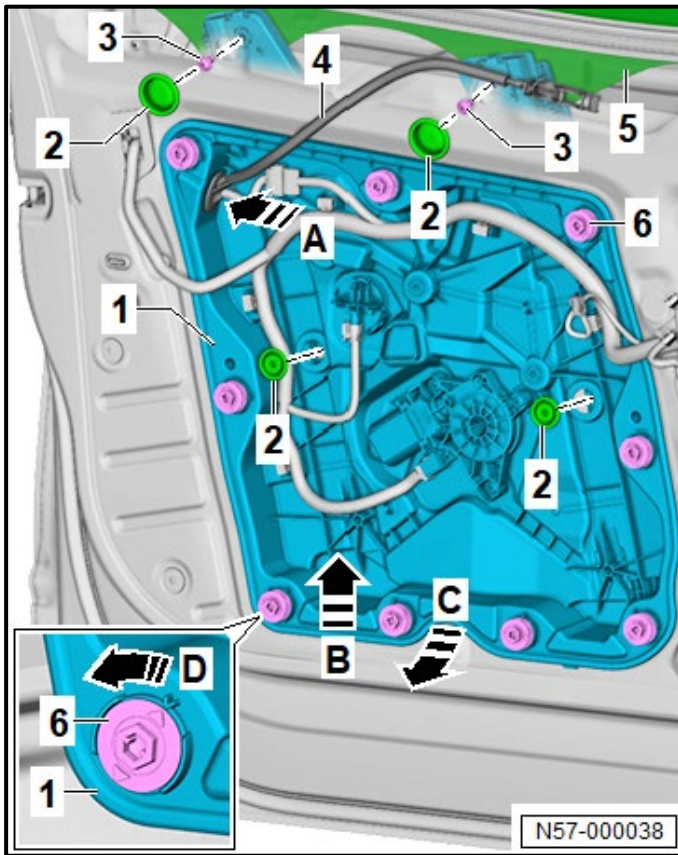

- Push the front door window <5> upward and secure it from falling using commercially available adhesive tape.
- Disconnect the connectors on the sub-frame components.
- Unclip the wires.
- Remove the bolts <3>.
- Turn the clips <6> in the direction of <arrow D> 90° and remove it slightly.
- Guide the release cable with the grommet <4> in the direction of <arrow A> out of the support <1>.
- Push the support <1> slightly in the direction of <arrow B>.
- Remove the support <1> in the direction of <arrow C> out of the door.

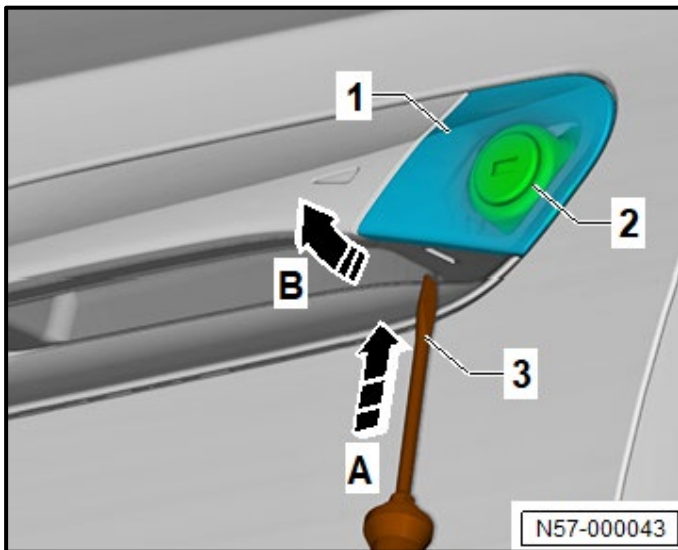

Remove lock cylinder (driver door only):

CAUTION

Risk of damaging component surfaces!

Do not turn the flat-head screwdriver.

Do not pry using a flat-head screwdriver.

- Press a small, commercially available flat-head screwdriver <3> in the direction of <arrow A> into the opening on the underside of the cap <1>.
- Unclip the cap <1> using a commercially available flat-head screwdriver <3>.
- Remove the cap <1> in the direction of <arrow B> from the lock cylinder <2>.

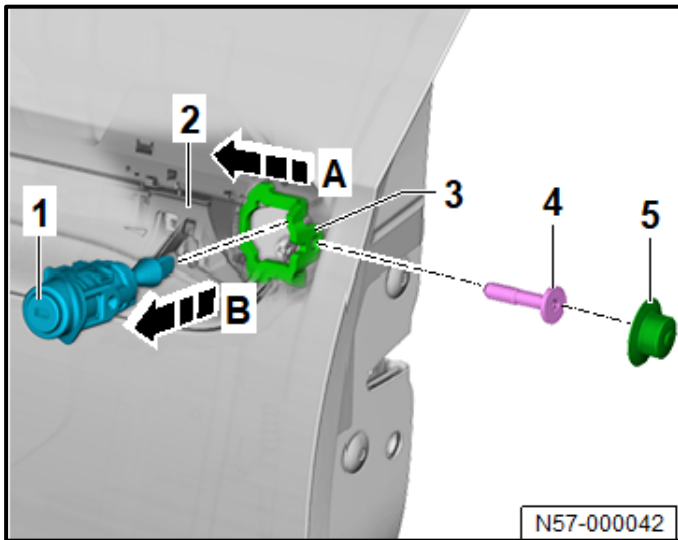

- Pry out the cap <5>.
- Remove the bolt <4> all the way.
- Press the bolt <4> with locking mechanism <3> in the direction of <arrow A> until the lock cylinder <1> is released.
- Remove the lock cylinder <1> in the direction of <arrow B> out of the mounting bracket <2>.

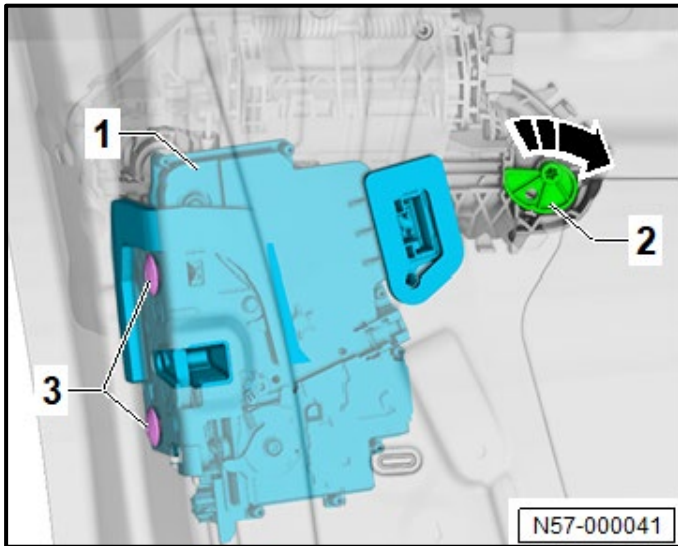

Lower the door lock unit:

- Disconnect the connector from the door lock unit <1>.
- Remove the bolts <3> and lower the door lock unit <1> downward.

NOTE

The door lock unit <1> does not have to be completely removed, only lowered out of the way.

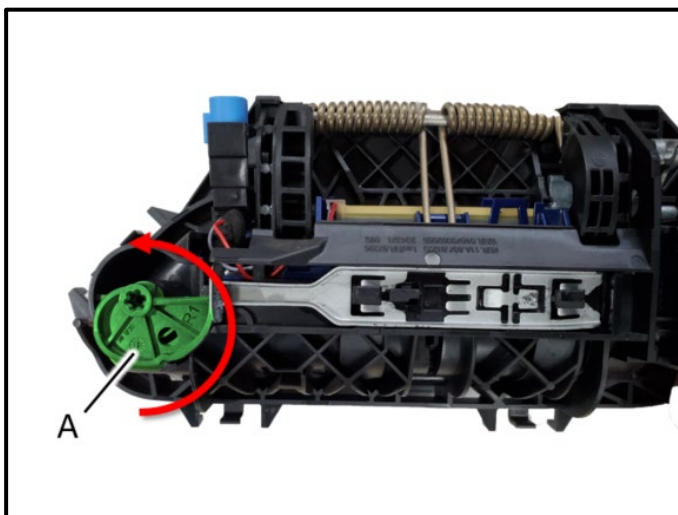

Remove door handle assembly:

NOTE

Front passenger side door handle shown removed for clarity. Procedure is similar for all doors.

- Rotate the eccentric cam <A> 270° using a T30 Torx screwdriver.
 - Clockwise for driver side.
 - Counter clockwise for passenger side.

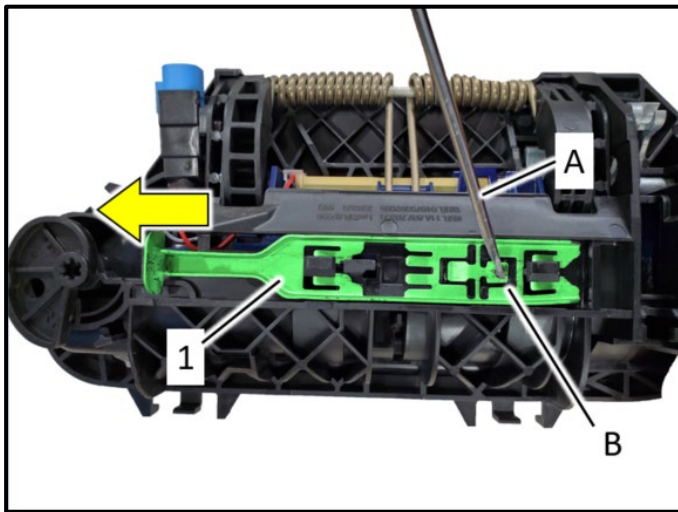

- Press on the locking tab with a screwdriver <A>.
- While holding the locking tab , slide the lock plate <1> in the direction of <arrow>.

TIP

A small amount of silicone spray can be used on the plate <1> if movement of the plate is stiff.

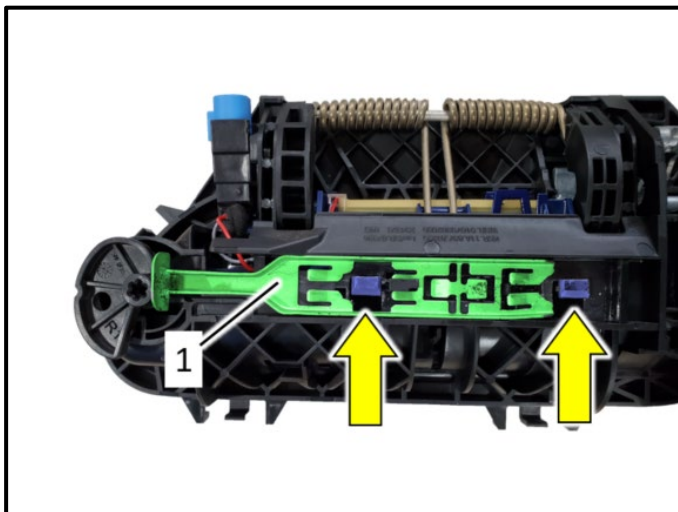

- Once the locking plate <1> is in the unlocked position (as shown), the pins <arrows> on the door handle will be released and the door handle assembly can be removed from the door.

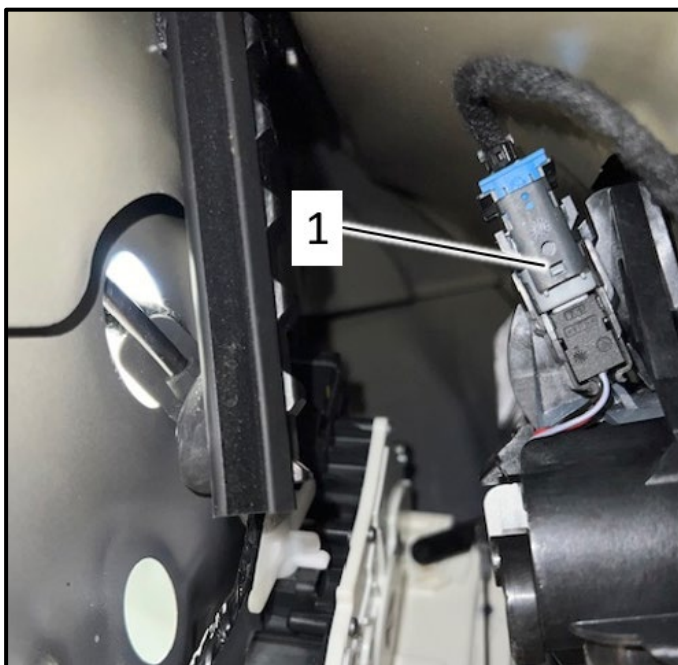

- Disconnect the connector <1> from the door handle assembly.

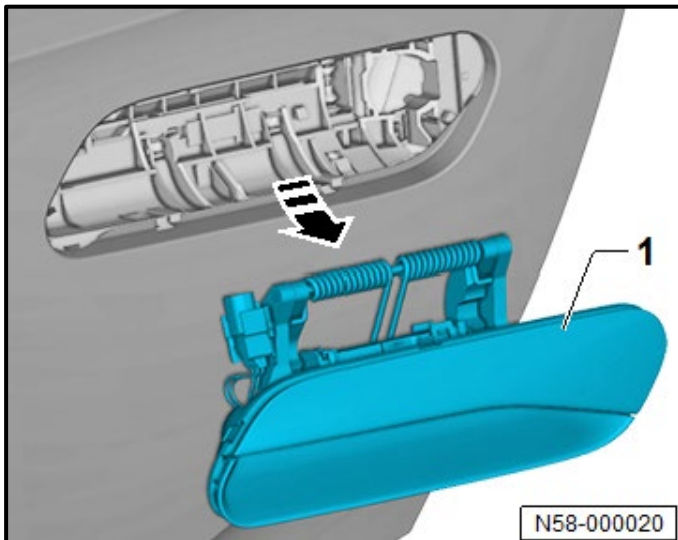

- Pivot out the door handle assembly <1> in the direction of <arrow> and remove.

See Section D for door handle replacement.

Proceed to Section C for rear door handle removal.

- Re-install door handle assembly in the reverse order of removal.

Reassemble the door components in the reverse order of removal while noting the following:

- Door lock unit bolts: 18 Nm
- Carrier for door component bolts: 8 Nm
- Door trim panel securing bolts: 4.5 Nm
- Replace any damaged door trim panel clips.

Section C – Rear Door Handle Assembly Removal and Installation

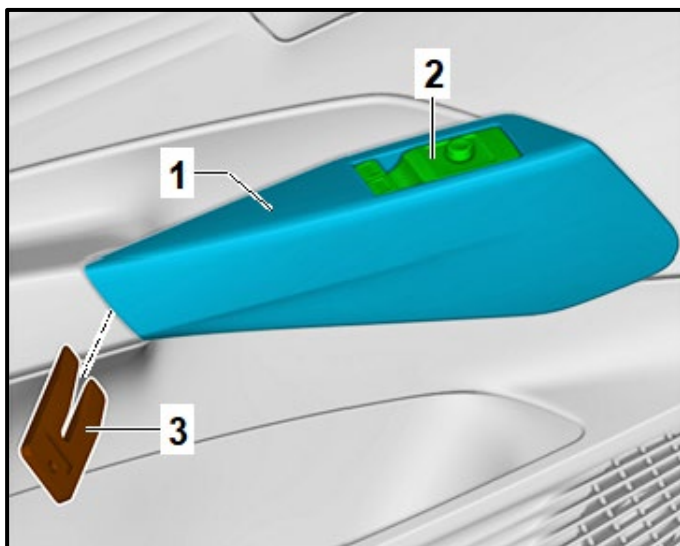

Remove button trim:

- Unclip the button trim <1> with controls <2> using the Wedge - T10383- <3>.
- Disconnect the connectors.
- Replace the button trim if damaged.



⚠ CAUTION

Risk of consequential damage!

When removing the button trim, it can release suddenly resulting in damage to the window switch. Use extreme care when removing the button trim.

- After the rear section of the button trim is loose, rotate the wedge in the direction indicated <red arrow> while carefully pulling the trim in the direction indicated <green arrow>.
- Driver's rear door shown. Procedure for all doors is similar.

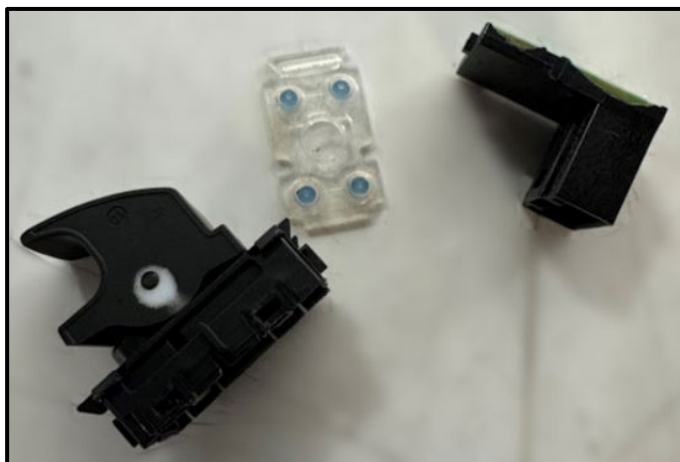

ⓘ NOTE

The switch shown is an example of the damage that can occur to the window switch if the button trim suddenly releases during removal.

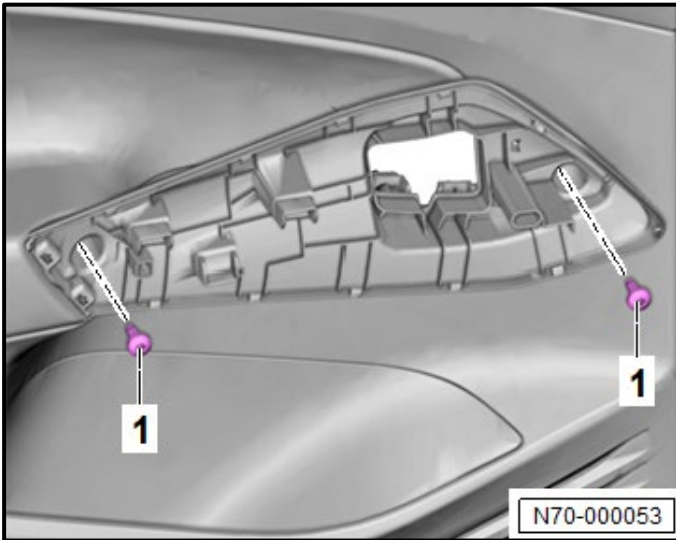

- Remove the bolts <1>.

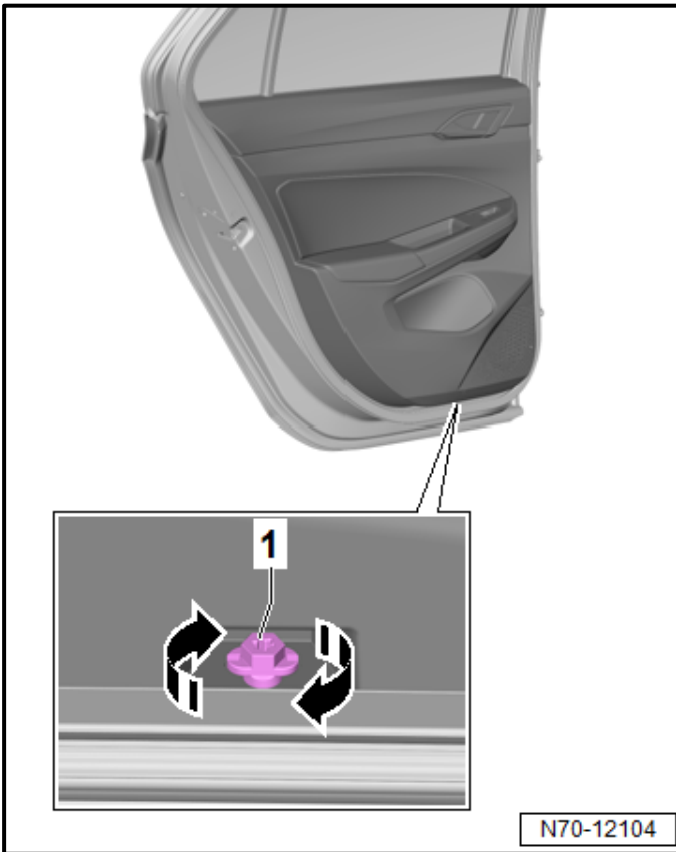

- Turn the rotating clip <1> 90° in the direction of <arrow> and release it.

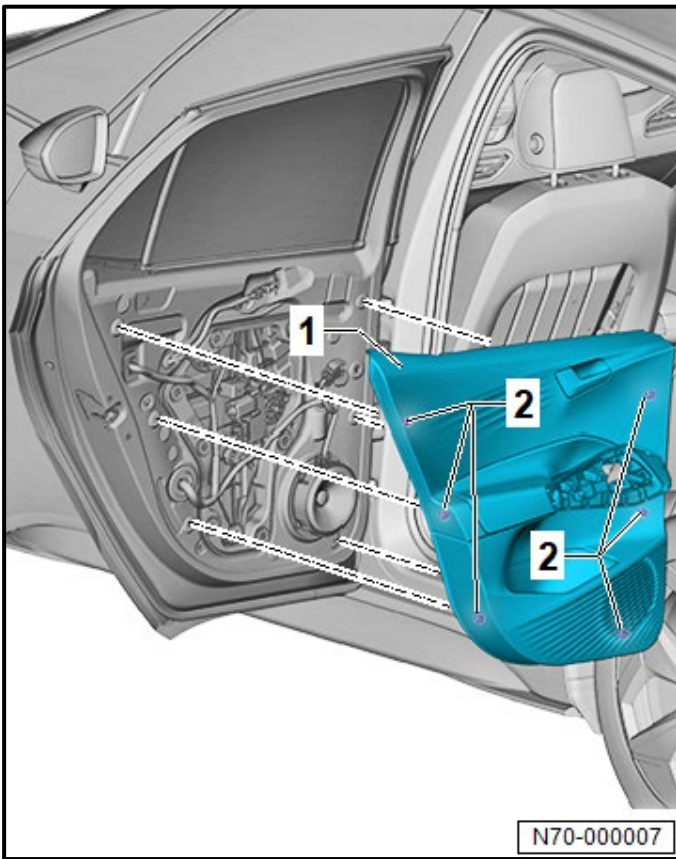

- Loosen the clips <2> for the rear door trim panel <1> using the Wedge Set -T10383-.
- Pull the rear door trim panel <1> upward out of the inner window shaft strip.
- Disconnect any connectors present.

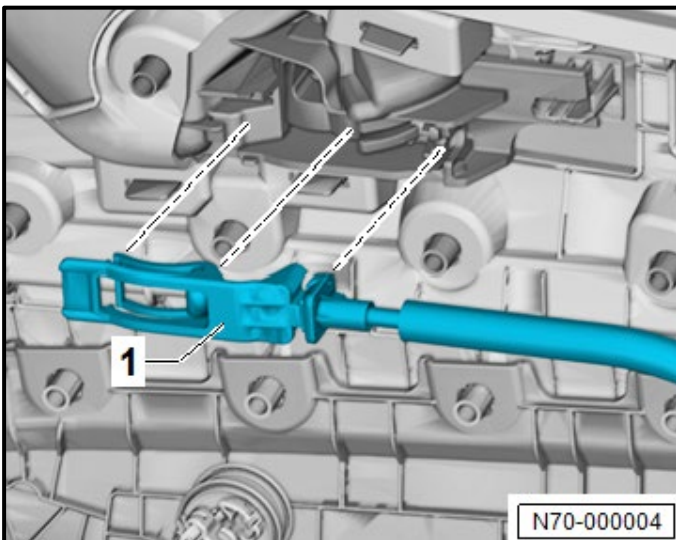

⚠ CAUTION

Risk of consequential damage!

There is a risk of damaging the release cable by deforming it. Do not bend or kink the release cable!

- Disengage the release cable <1>.

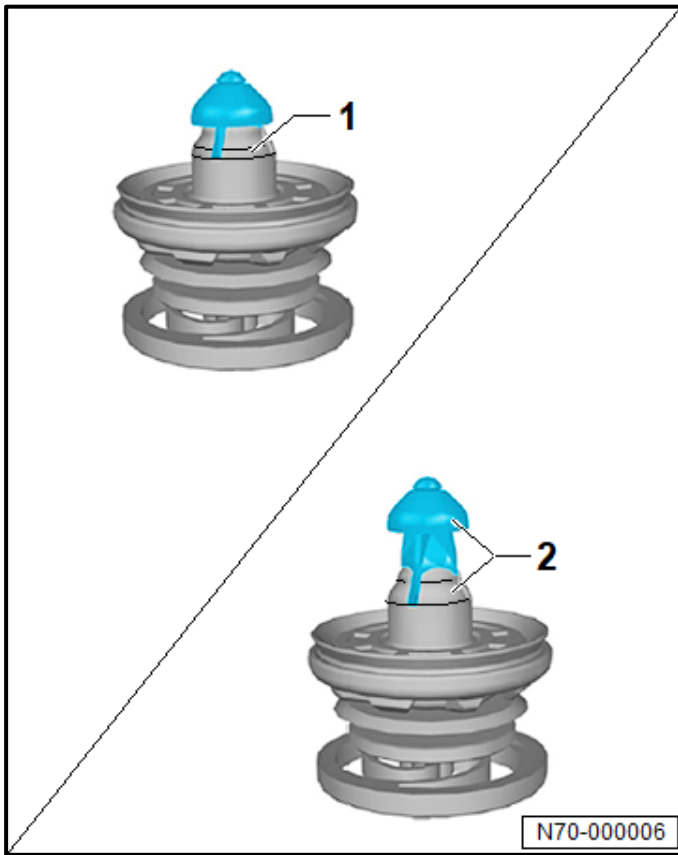

⚠ CAUTION

- Risk of damaging the locking mechanism.**
- Always turn the locking mechanism from position <2> to position <1>.
 - The door trim panel can only be installed when the locking mechanism is in position <1>.

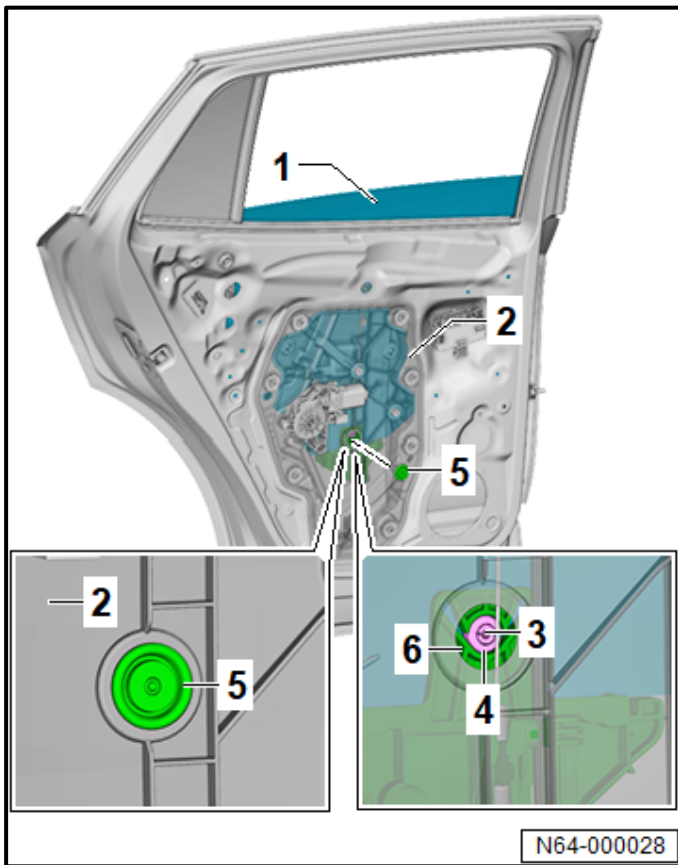

Loosen the rear door window from the window regulator.

- Pry the cap <5> out of the subframe <2> using a commercially available plastic wedge.
- Temporarily install the window switch and lower the rear door window <1> until the expanding pin <3> and spreader plug <4> are accessible through the opening in the subframe <2>.
- Remove the expanding pin <3> from the spreader plug <4> using the Release Tool -T10615-.
- Remove the spreader plug <4> from the window regulator guide <6> using the Release Tool -T10615-.
- Push the rear door window upward and secure it from falling using adhesive tape.

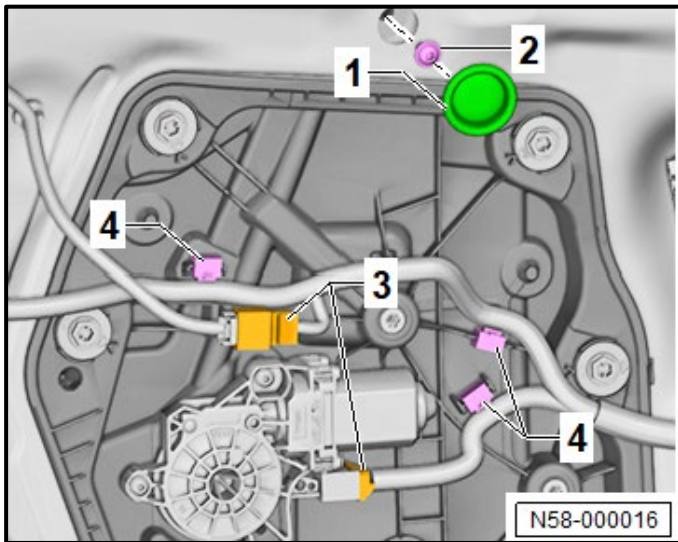

- Pry out the plugs <1>.
- Remove the bolt <2>.
- Disconnect the connectors <3>.
- Loosen the clips <4> and move the wires to the side.

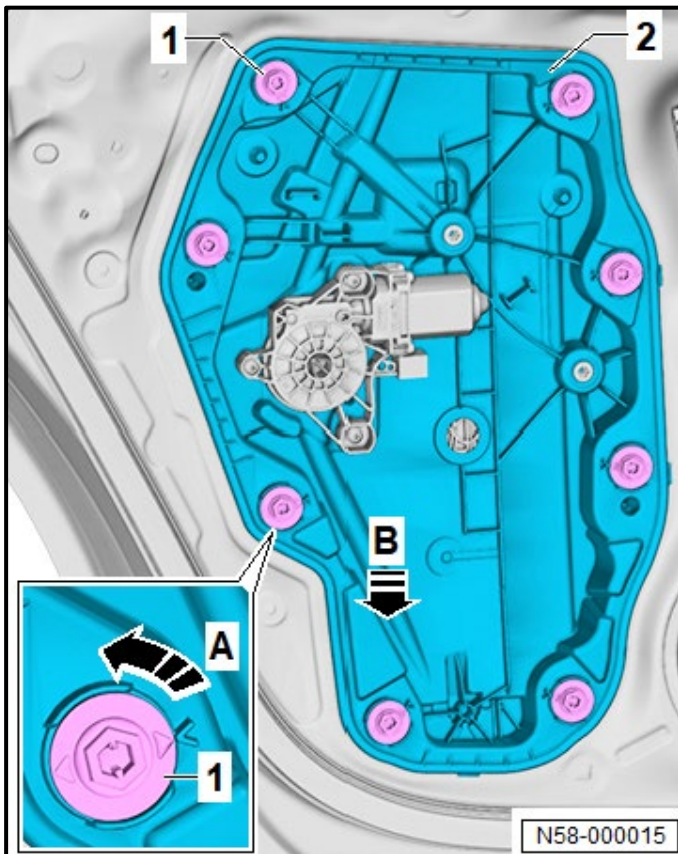

- Turn the clips <1> 90° in the direction of <arrow A> and pull them out slightly.
- Remove the door components carrier <2> in the direction of <arrow B> out of the door.

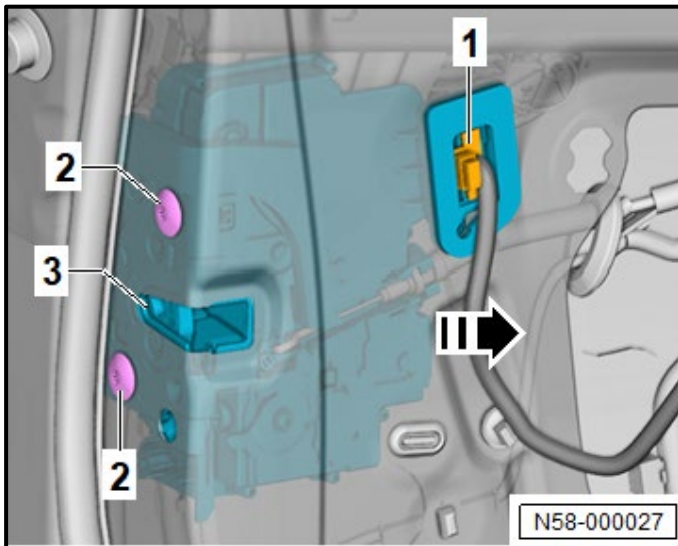

Lower the door lock assembly:

- Disconnect the connector <1>.
- Remove the bolts <2> and lower the rear Door Lock Unit <3> downward.

NOTE

The door lock unit <1> does not have to be completely removed, only lowered out of the way.

TIP

The door cable connection <1> can be unlocked to aid in lowering the door lock. The cable does not have to be completely removed, only unlocked so it can move freely.

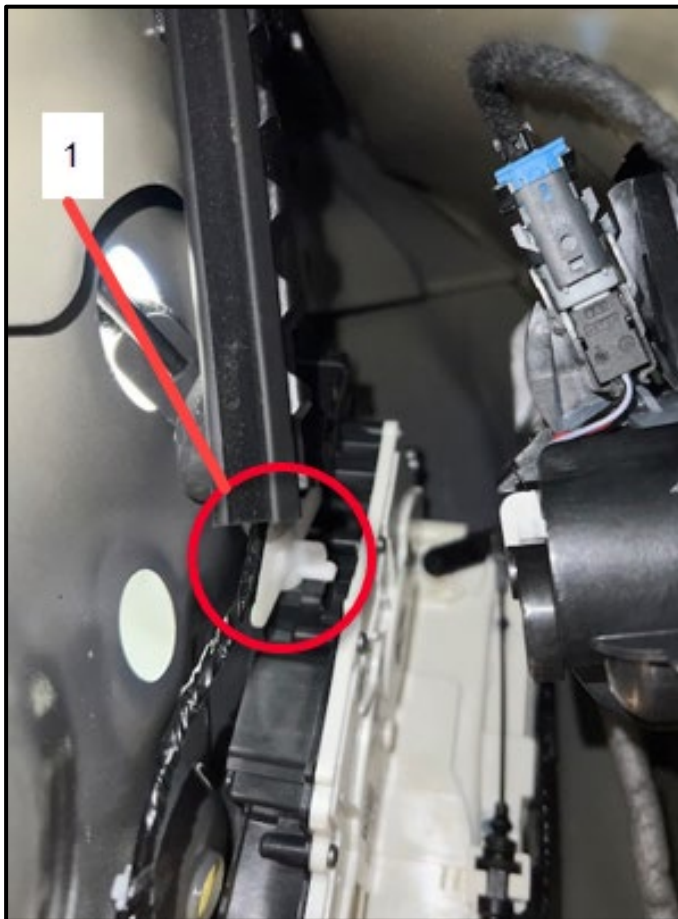

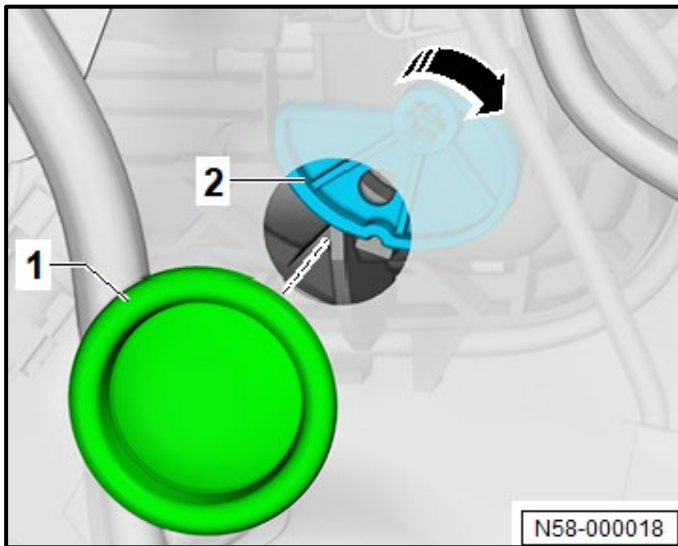

- Pry out the plug <1>.

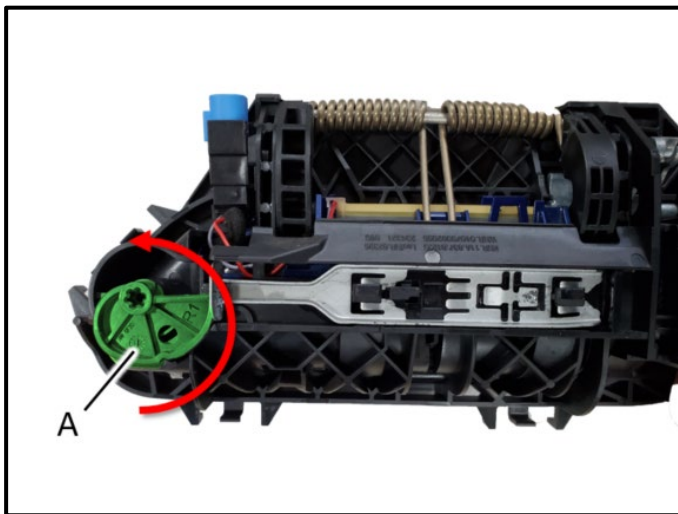

Remove door handle assembly:

⚠ NOTE

Passenger side door handle shown removed for clarity. Procedure is similar for all doors.

- Rotate the eccentric cam <A> 270° using a T30 Torx screwdriver.
 - Clockwise for driver side.
 - Counter clockwise for passenger side.
- Push the pushover plate <1> all the way in the direction indicated <arrow>.

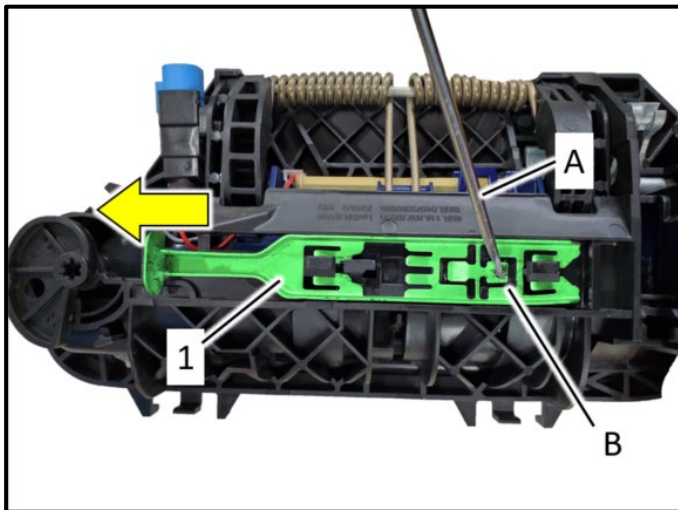

- Press on the locking tab with a screwdriver <A>.
- While holding the locking tab , slide the lock plate <1> in the direction of <arrow>.

i TIP

A small amount of silicone spray can be used on the plate <1> if movement of the plate is stiff.

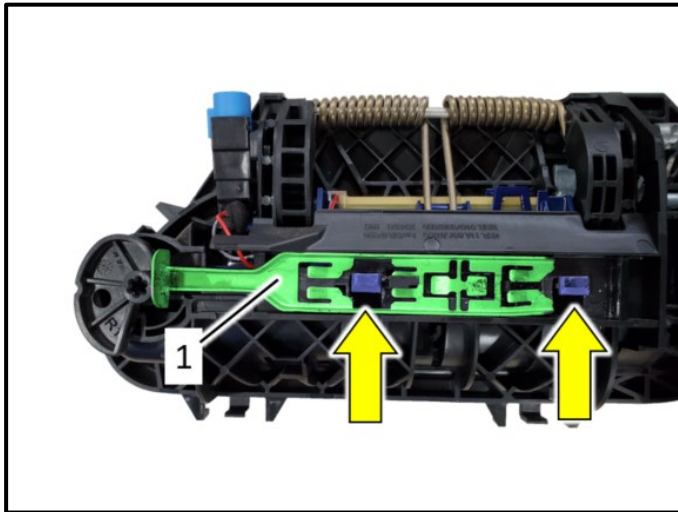

- Once the locking plate <1> is in the unlocked position (as shown), the pins <arrows> on the door handle will be released.

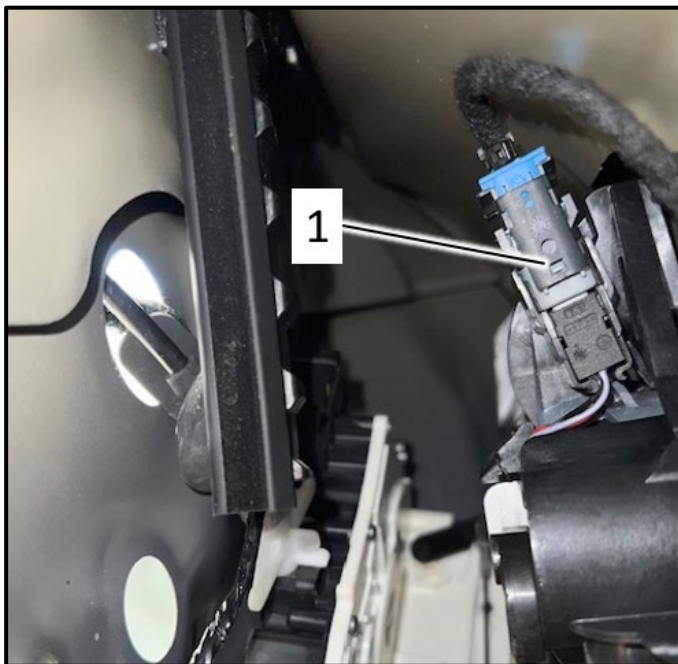

- Disconnect the connector <1> from the door handle assembly.

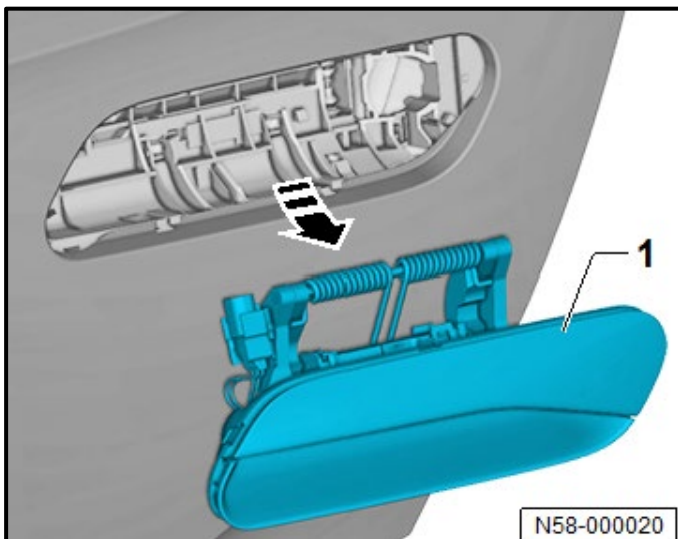

- Pivot out the door handle assembly <1> in the direction of <arrow> and remove.

See Section D for door handle replacement.

- Re-install door handle assembly in the reverse order of removal.

Reassemble the door components in the reverse order of removal while noting the following:

- Door lock unit bolts: 18 Nm
- Carrier for door component bolts: 8 Nm
- Door trim panel securing bolts: 4.5 Nm
- Replace any damaged door trim panel clips.

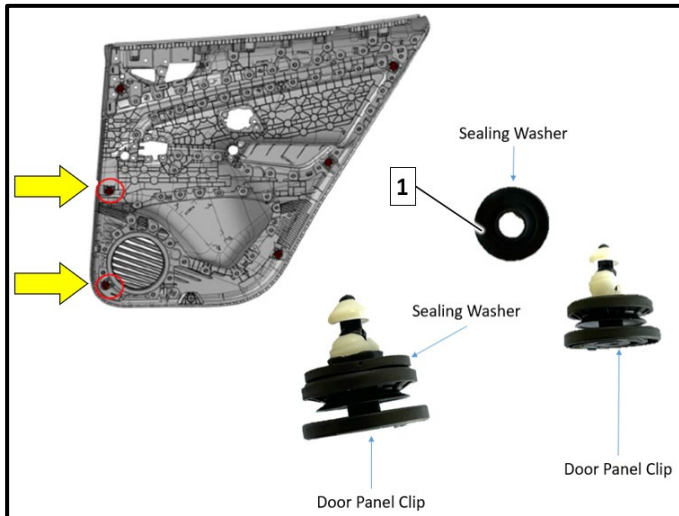

Criteria 02 vehicles only:

⚠ CAUTION

Risk of water leak!

- The door panel clips in the areas shown <arrows> include an additional sealing washer <1>.
- Ensure the sealing washer is not discarded and ensure it remains on the door panel clip.
- If the door panel clip is replaced, the sealing washer <1> must be transferred to the new clip.
- If the washer is not present on the old clip, check if the seal is stuck to the door and transfer it to the new clip as necessary.
- If the sealing washer is missing and must be replaced, the only way to obtain one is to order CLIP part number WHT-009-448 and remove the washer from the new clip.

Section D – Door Handle Replacement

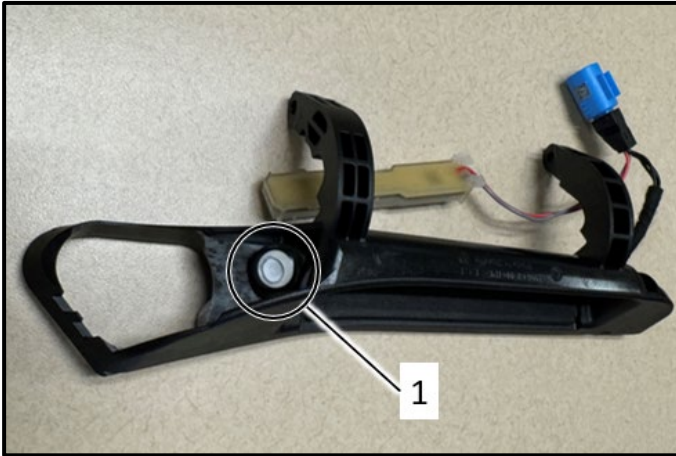

CRITICAL REPAIR STEP

 **STOP!** 

Do not touch or allow anything to contact the vapor membrane <1> located on the back of the new door handles.

Old door handle:

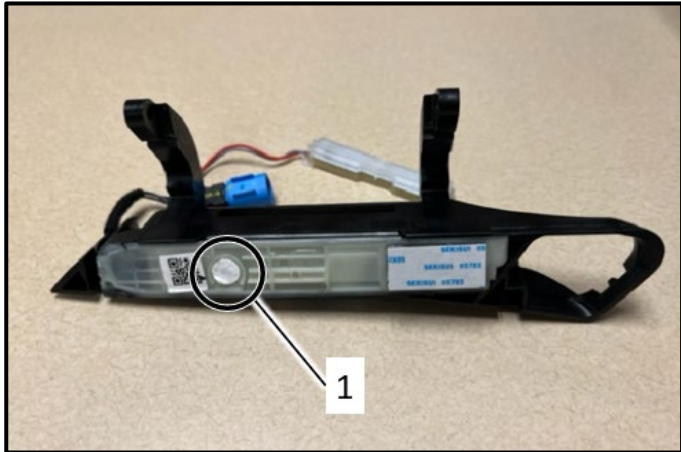

New door handle:

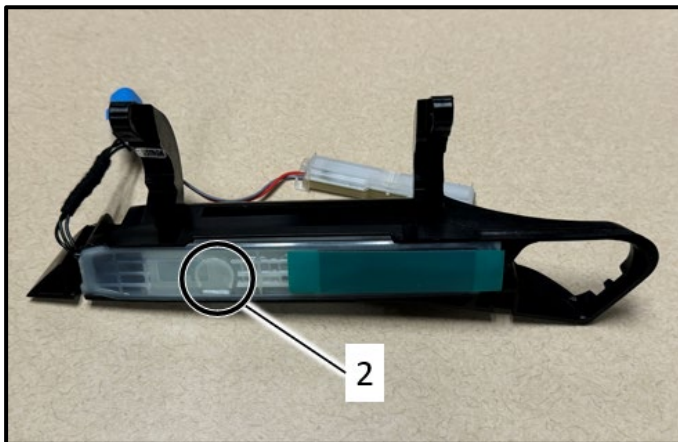

New door handle:

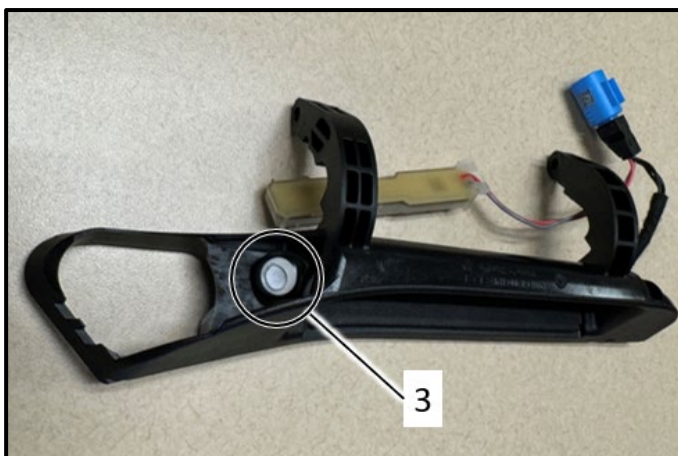

⚠ CRITICAL REPAIR STEP

STOP! STOP!

- To ensure the new and old door handles are not mixed up, mark the door handles accordingly.
- The old door handles have the membrane located on the front of the door handle in the area indicated <1>.
- The new door handles do not have a membrane or an opening in the area indicated <2>.
- The new door handle can also be identified by the presence of the membrane on the back of the assembly in the area indicated <3>.

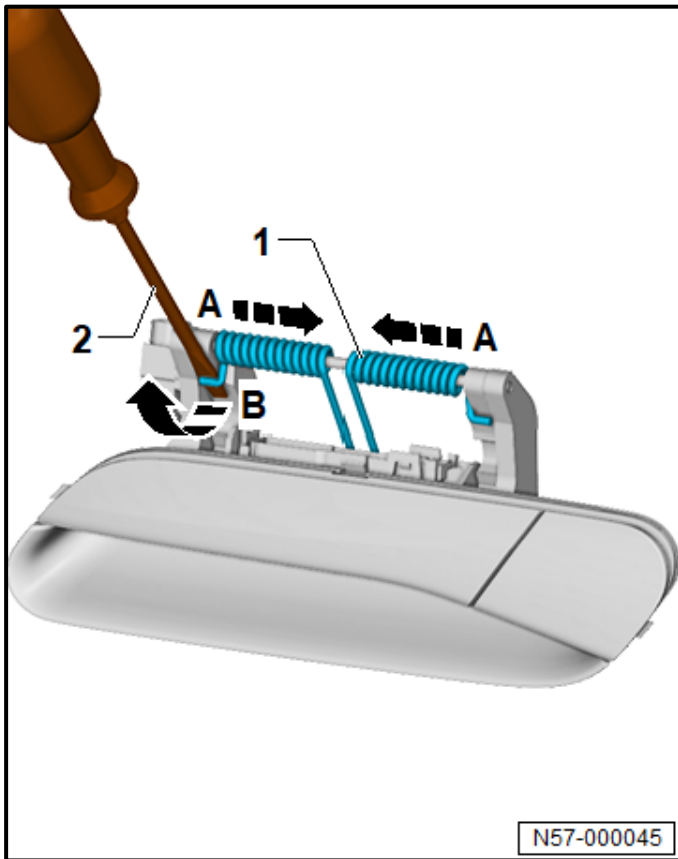

Remove spring:

⚠ CAUTION

Risk of injury!

Spring is under tension! Use caution when releasing the spring!

- Push the spring <1> in the direction of <arrow A>.
- Turn the spring <1> using a Flat-Head Screwdriver <2> 90° in direction of <arrow B> and then remove from the mount.

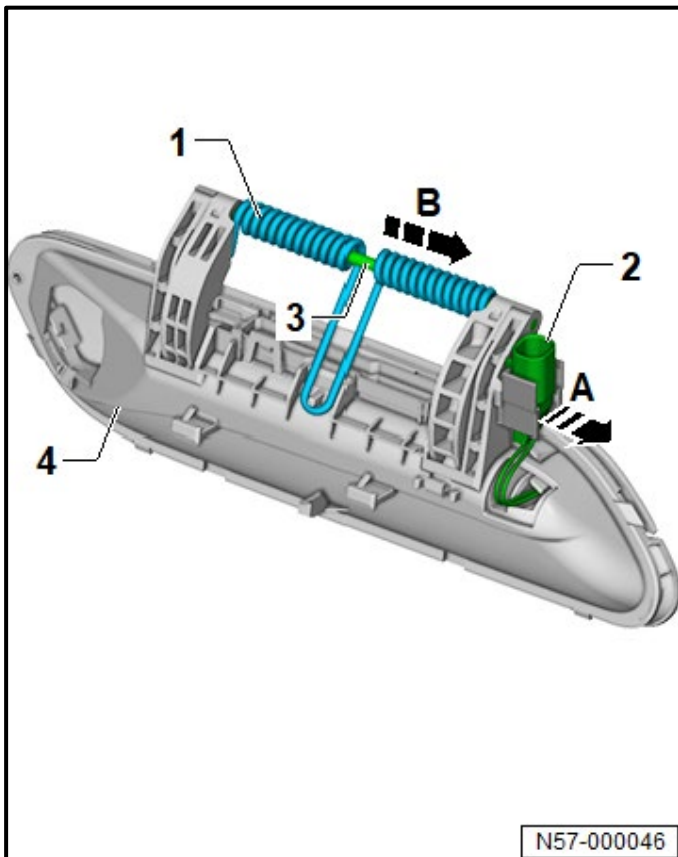

- Disengage the connector for the exterior door handle illumination and exterior door handle touch sensor <2> in the direction of <arrow A>.
- Note the installation position of the spring.
- Drive out the pin <3> in the direction of <arrow B> using a Drift Punch and remove the pin.
- Remove the spring <1> from the door handle <4>.

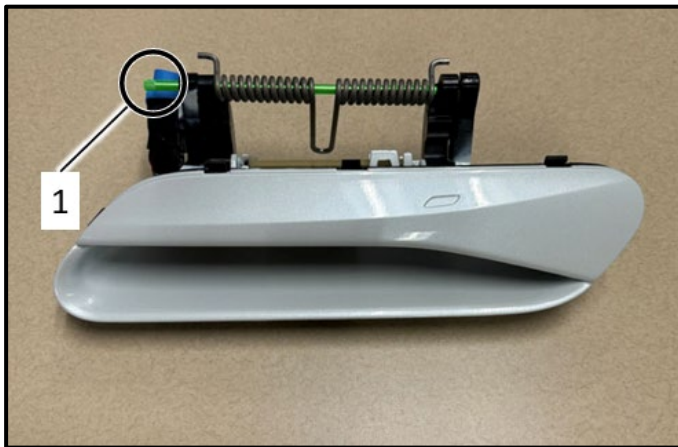

NOTE

Pin <1> shown partially removed to show the splines. Only one side of the pin has splines.

- Drive out the pin <1> using a suitable punch from the side of the pin that does not have splines.

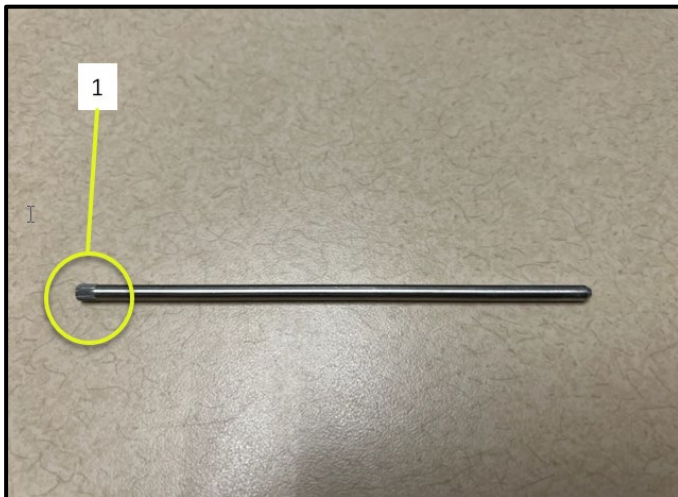

NOTE

Pin shown removed for clarity.

Note the splined end <1>.

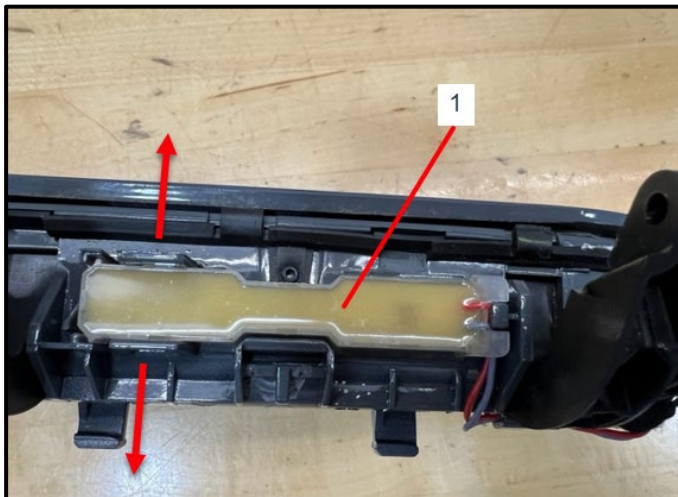

Remove lamp:

- With the pin and spring removed, release the door handle lamp <1> by spreading the tabs in the direction indicated <arrows>.

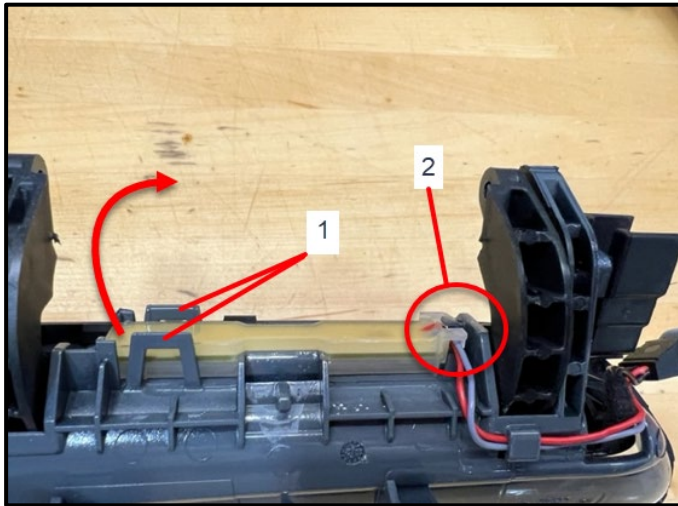

- Once the tabs <1> have been released, rotate the lamp out of the retaining tab <2> in the direction indicated <arrow>.

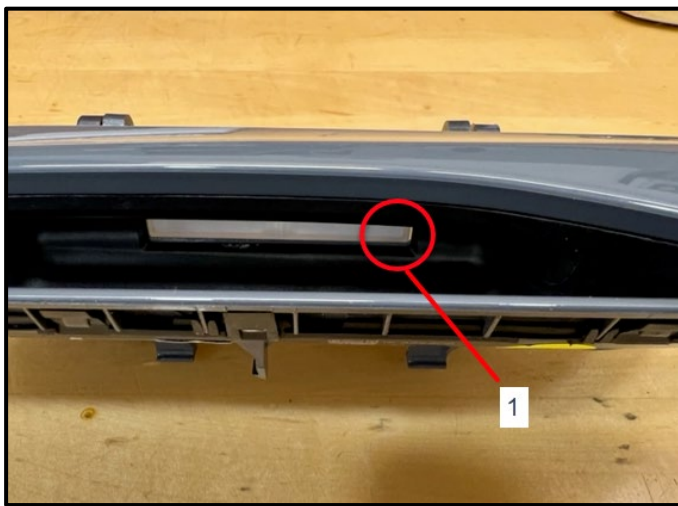

- To aid in removal of the lamp, once the tabs have been released, using a few fingers, push on the lamp from inside the handle in the area shown <1>.

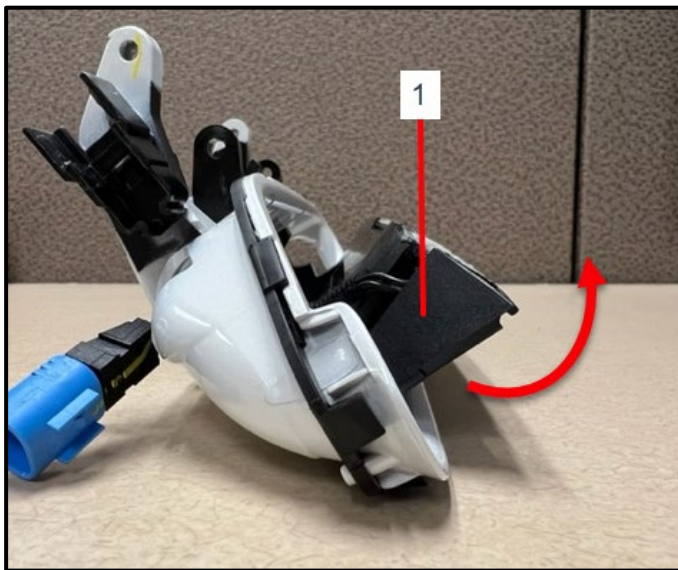

Remove door handle from the carrier:

- Carefully rotate the door handle <1> out in the direction indicated <arrow>.
- Feed the lamp and connector housing out of the carrier.

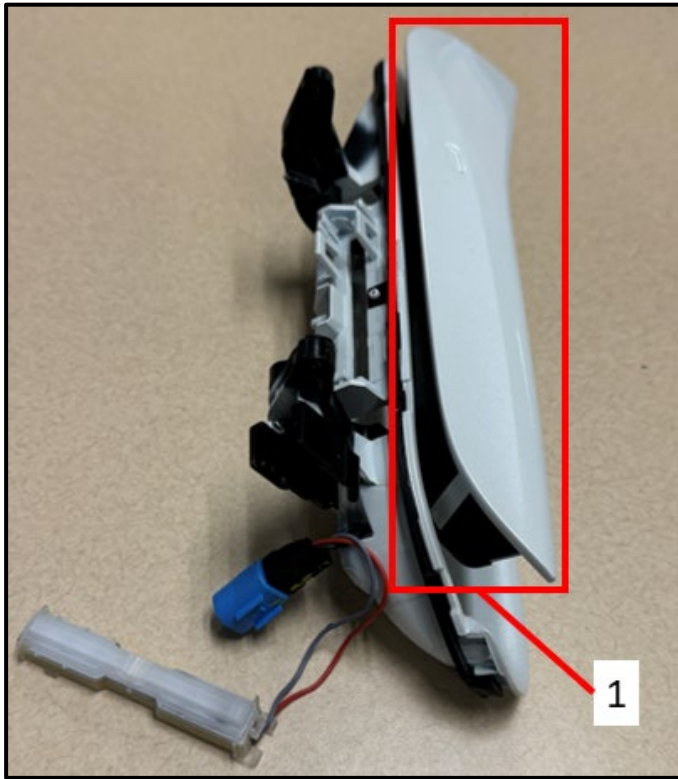

NOTE

Door handle <1> shown from a different angle for clarity.

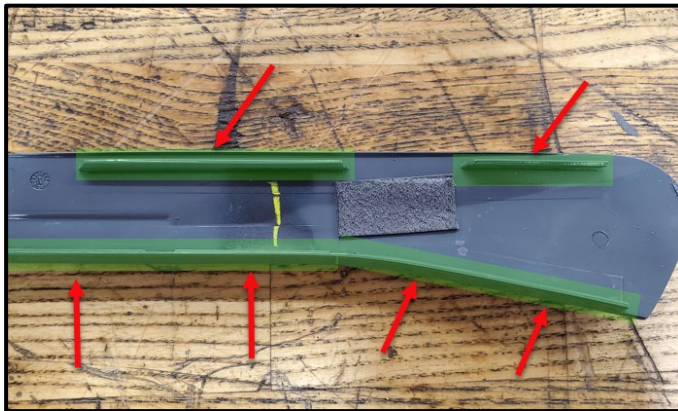

Remove old door handle cover:

- Carefully unclip the door handle trim cover from the original door handle.

TIP

The door handle covers are held in by retaining tabs <arrows>. On the bottom, the retaining tabs run the length of the cover.

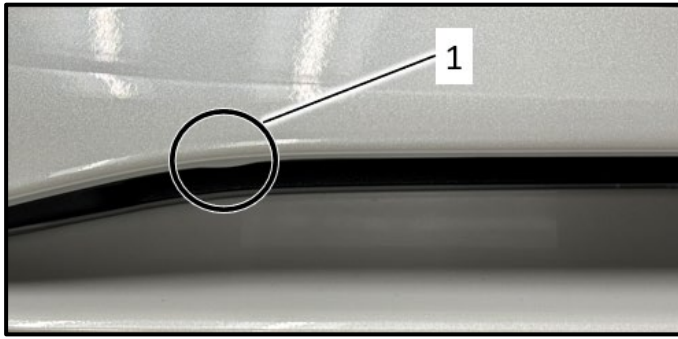

**CRITERIA 02 VEHICLES USING “11A” PARTS -
Modify front and rear door handle covers:**

⚠ CAUTION

If the door handle cover is not modified or is modified incorrectly, the cover will not sit flush and there will be raised areas along the bottom of the cover. The cover pictured has not been modified in the rear section and is not sitting flush in the area indicated <1>.

ⓘ NOTE

The modification is needed for criteria 02 vehicles ONLY when using door handle part numbers starting with 11A.

- Cover the outward facing surface as needed to protect the exterior painted surface of the door handle cover from damage.



- Take note of the areas to be modified on the door handle cover <arrows>.

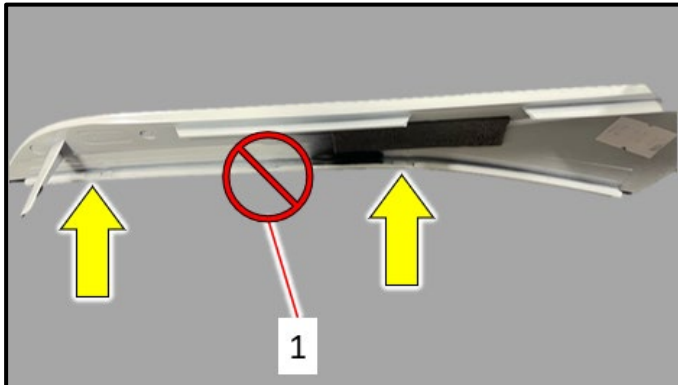

ⓘ NOTE

The center section of the door handle cover <1> does not require modification.

- Starting at the front notch, measure 15-17mm towards the rear of the cover as shown <1>.
- Mark the measurement as needed.

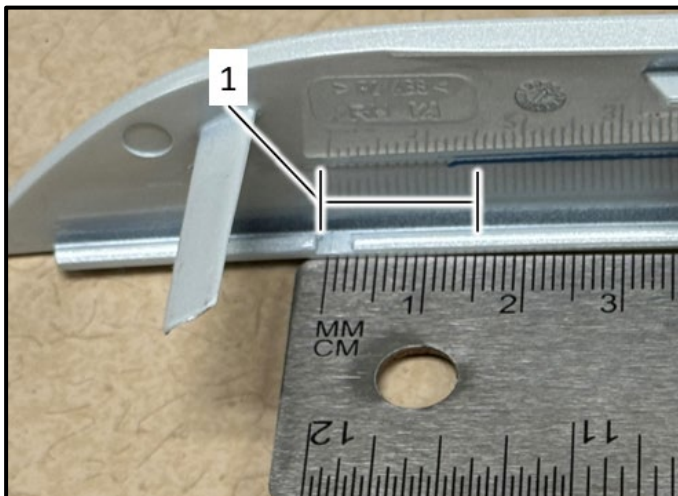

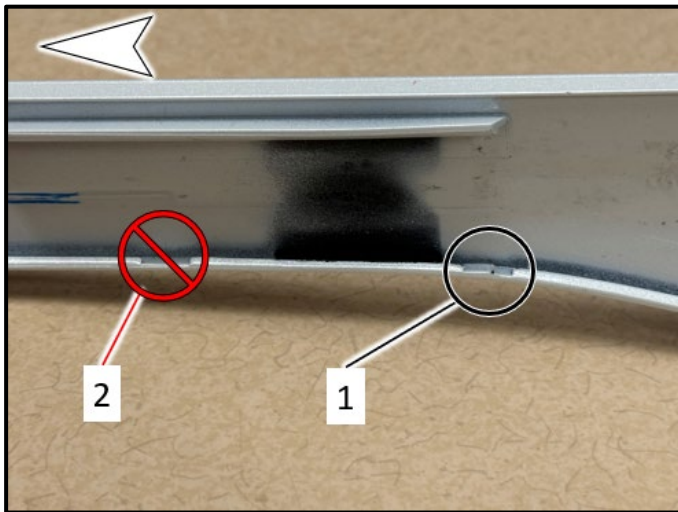

- Mark the retaining “tooth” <1> at the rear of the cover.

NOTE

For reference, the front of the cover is in the direction indicated <arrow>. Only modification of the retaining tooth <1> is required for the rear of the cover. Unlike the front section of the cover, the width of the rear section is unchanged. Do not modify the center section of the cover <2>.

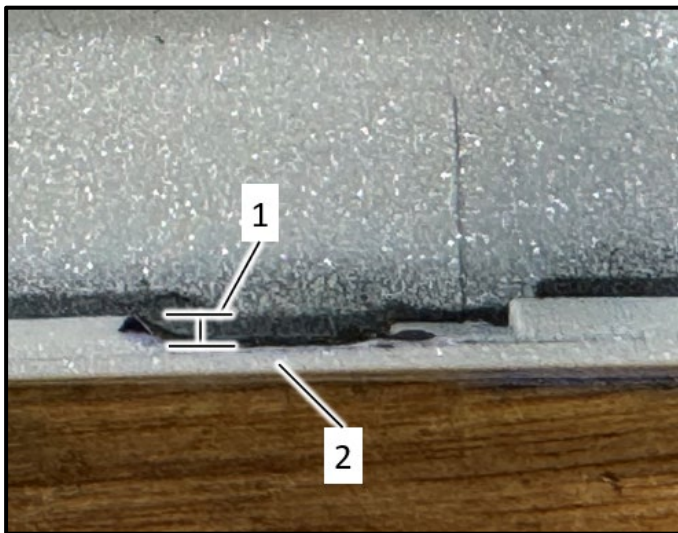

CAUTION

Risk of irreparable damage!

The cover modifications must not be visible when the cover is installed. The depth of the modification <1> must not be so deep that the exterior of the cover <2> is damaged. Only remove enough material so that retaining tabs are flush with the bottom of the cover.

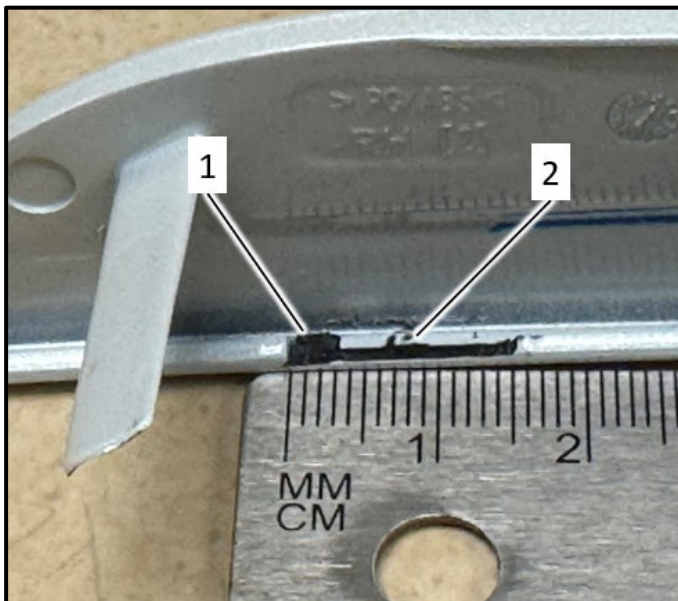

- Secure the cover as needed to prevent movement while performing the modification.
- Using a commercially available rotary tool and carbide grinding bit, carefully remove the “tooth” <1> and the retaining tab <2> at the front of the cover in the area previously marked until flush with the bottom of the cover.

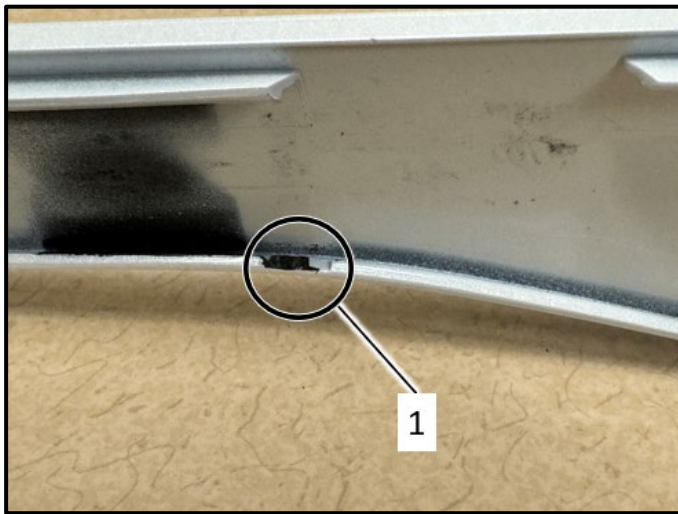

- Using the rotary tool and carbide bit from the previous step, carefully remove the “tooth” <1> in the area previously marked towards the rear of the cover until it is flush with the bottom of the cover.
- Remove any debris generated from the modification of the cover.
- Repeat these steps for the remaining door handle covers.



Continuation for all vehicles:

- Remove the old foam tape <1> from the front door handle covers.



- Using isopropyl alcohol and a lint free cloth, clean the area <1> where the foam tape was.
- Ensure no residue remains.
- Allow the cleaner to dry completely.

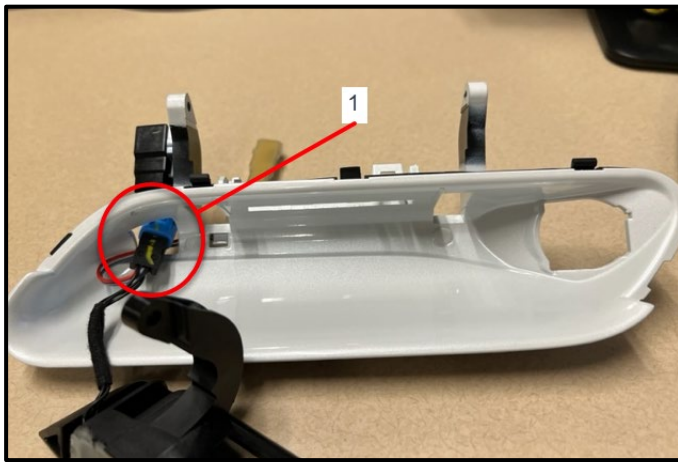

Installing new door handle:

- Feed the door handle lamp and connector through the carrier in the area indicated <1>.



- Insert the new door handle <1> into the carrier in the reverse order of removal.
- Install the connector and lamp back into their retainers in the carrier.

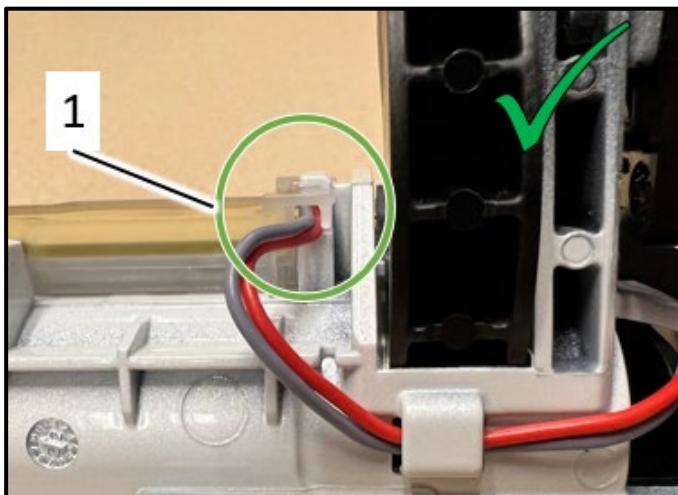

CAUTION

Risk of damage!

When installing the lamp back into the carrier, be mindful of the wire positioning or damage can occur.

- Correct installation of wires <1> shown.

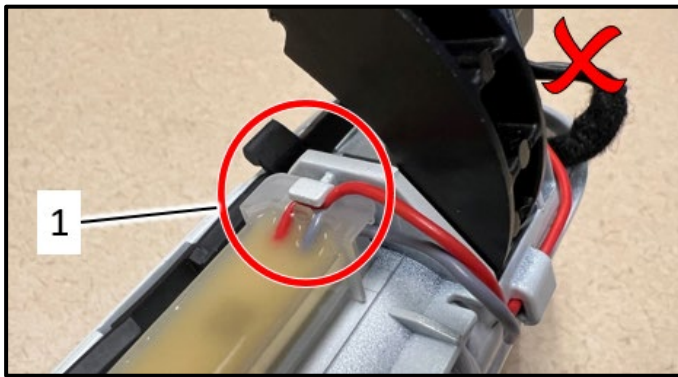

- Incorrect installation of wires <1> shown.

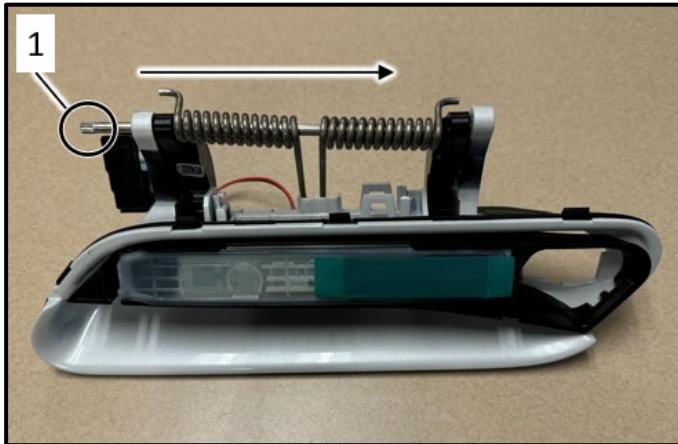

Reinstall the spring:

⚠ CAUTION

Risk of injury!
Spring is under tension! Use caution when reinstalling the spring!

- Reinstall the spring with pin <1> in the direction indicated <arrow>.

ⓘ NOTE

Be mindful of the direction the spring is installed. See the images below for examples of correct and incorrect installation.

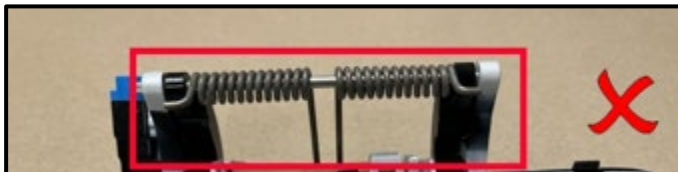

- Incorrect spring installation = Spring tabs facing the front of the door handle.

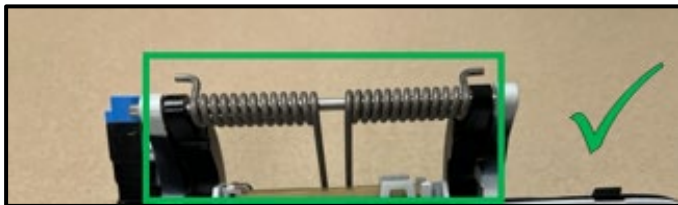

- Correct spring position = Spring tabs facing the back of the door handle.

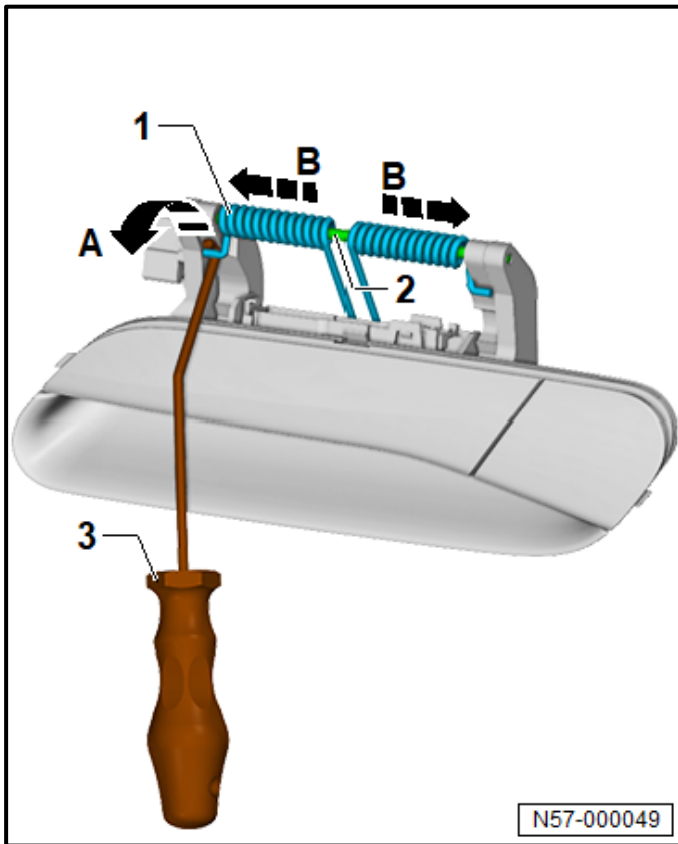

- Turn the spring <1> 90° in direction of <arrow A> using the Assembly Tool -T10118- <3>, until the hook engages in the mount.
- Push apart the spring <1> in the center area <2> in the direction of <arrow B>.

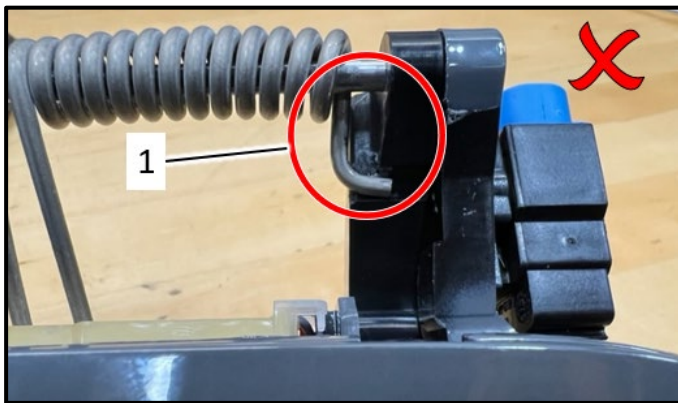

- Spring tab <1> that is not fully engaged.

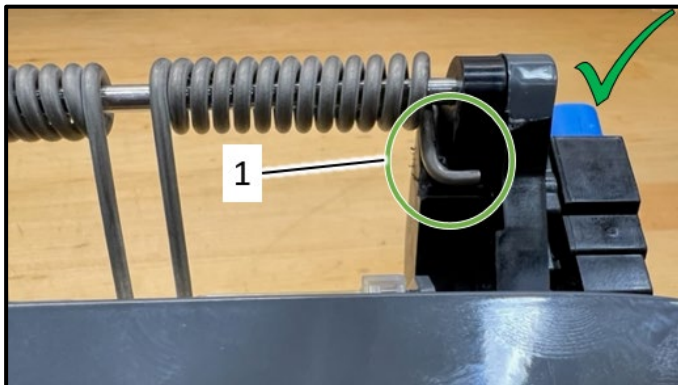

- Spring tab <1> that is fully engaged.

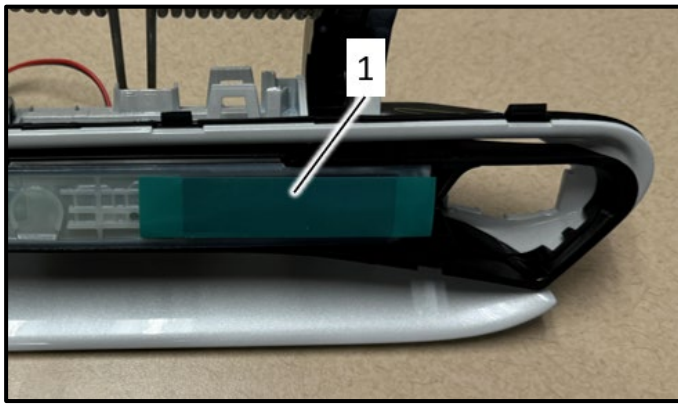

Install door handle cover:

- Front door handles only:
 - Remove the adhesive backing from the foam pad <1>.



- Reinstall the door handle cover.
- Ensure it's fully clipped into place.
- Front door handles only: Press firmly in the area shown to adhere the foam pad to door handle cover.

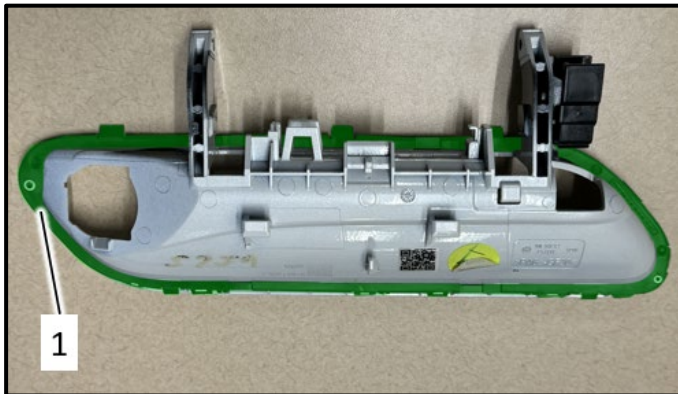

Check gasket for damage:

- Check door handle gasket <1> for damage and replace if necessary.

Re-install door handle assembly into door:

- Refer back to Sections B and C for re-installation instructions.
- Vehicles with Criteria 01:
 - A software update is necessary.
 - Proceed to Section F
- Vehicles without Criteria 01:
 - No software update is necessary.

- Proceed to Section G after all door handles have been replaced.

Section F – Update Door Control Modules

NOTE

Prior to launching the VAS Diagnostic Tester and starting an update, ensure the following conditions are met;

- ✓ **The ODIS software is completely up to date.**
 - Refer to the “Current ODIS Service Version” circular found in Elsa2Go Service References.
- ✓ **The battery charger is connected to the vehicle battery and remains connected for the duration of the software update.**
 - Battery voltage must remain above 12.5 volts **(or higher, if directed in the work instructions)** for the duration of the software update. Failure to do so may cause the update to fail, which could result in damage to the control module. Control modules damaged by insufficient voltage will not be covered.
- ✓ **The screen saver and power saving settings are off.**
 - Failure to do so may result in the tester entering power save mode during the software update, which could result in damage to the control module.
- ✓ **The VAS Diagnostic Tester is plugged in using the supplied power adapters.**
 - Under no circumstances should the tester be used on battery power alone during the software update. Failure to do so may result in the tester powering off during the update, which could result in damage to the control module.
- ✓ **The VAS Diagnostics Interface MUST ONLY be connected to the tester with a USB cable.**
 - Performing a software update using a Bluetooth or WiFi connection increases the risk of losing connection during the update, which could result in damage to the control module. It also greatly increases the time required to perform the update. Requests for additional time or parts will be denied if the GFF log shows the update was performed using Bluetooth or WiFi.

NOTE

- Damages resulting from improper repair or failure to follow these work instructions are the dealer's responsibility and are not eligible for reimbursement under this action.
- Diagnosis and repair of pre-existing conditions in the vehicle are not covered under this action.

NOTE

- All campaign software updates must be completed during a single, standalone ODIS Diagnostic Session. You must fully complete this campaign and send all logs before beginning any other campaigns or operations.
- If there are any ODIS “Hot-Fix” patches installed, they must be removed from the scan tool before beginning this operation. ODIS “Hot-Fix” patches may affect the update process.

⚠ IMPORTANT

To Update-Programming using SVM, review and follow instructions in Technical Bulletin 2014603: *Software Version Management (SVM) Operating Instructions*.

The SVM Process must be completed in its entirety so the database receives the update confirmation response. A warranty claim may not be reimbursed if there is no confirmation response to support the claim.

- Switch off all consumers, air conditioning, heater blower motor, lights, heated seats, etc.
- Connect battery charger.
- Ensure the latest version of ODIS is downloaded.
- Ensure diagnostic head is connected to ODIS tester via USB cable.
- Move selector lever to P.
- Select "SVM – Code Input".
- Enter SVM code **4BE4** and follow the on screen prompts.



⚠ IMPORTANT

If criteria 01 is not assigned to the VIN, the software update is not needed.

- Ensure the diagnostic log is sent to GFF Paperless after completion.

Proceed to Section G

⚠ IMPORTANT

If the software update fails for any reason, ODIS feedback must be sent prior to further diagnosis. This ensures the failure/error is reported. Failure to do so may result in non-payment of consequential requests for additional time or parts.

Section G – Campaign Completion Label

Install Campaign Completion Label

- Fill out and affix Campaign Completion Label, part number CAMP 010 000, next to the vehicle emission control information label.



TIP

Ensure Campaign Completion Label does not cover any existing label(s).

Proceed to Section H

Section H - Parts Return/Disposal

Properly store (retain), destroy or dispose of removed parts in accordance with all state/province and local requirements, unless otherwise indicated and/or requested through the Warranty Parts Portal (WPP) for U.S. and the Part Destruction and Core Disposition Report for Canada.