

Figure 1. Top Cover (One-up Seat Models)

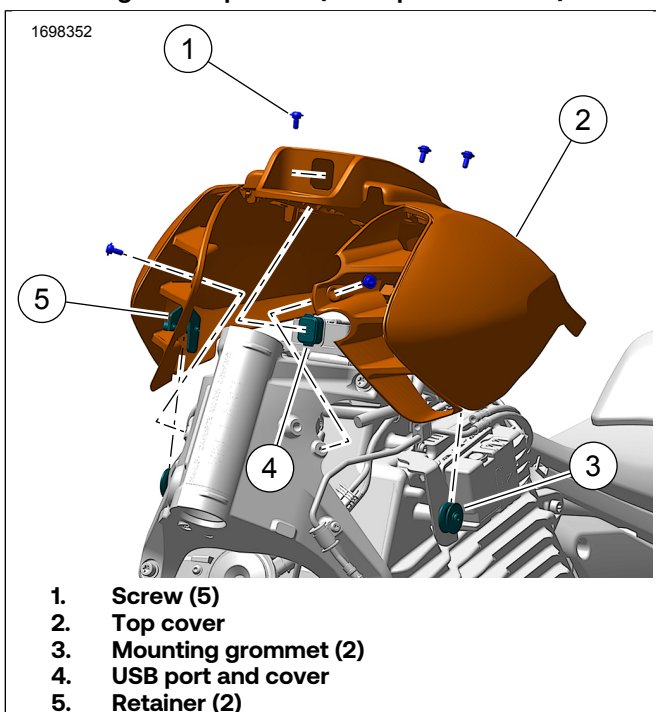

Figure 2. Top Cover (Two-up Seat Models)

2. **S2MH:** Remove fuse trim panel.
3. Remove brake line P-Clip screw.
4. Remove RESS fuse assembly.

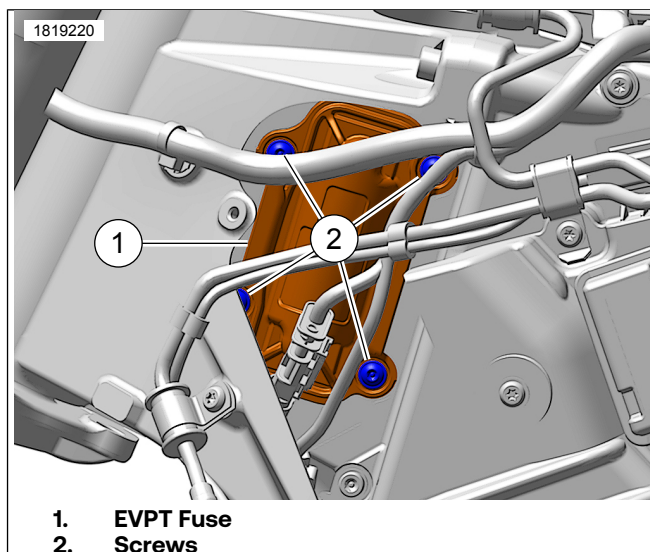

Figure 3. EVPT Fuse

INSTALL

1. Inspect mating surfaces.
 - a. Ensure RESS and fuse caddy seal are free from debris and damage.
 - b. Ensure seal is seated in caddy.
2. Install replacement RESS fuse assembly.
 - a. Replacement fuse assembly must have green paint mark, located on the exterior of the caddy.
 - b. Tighten.
Torque: 2.2–2.6 N·m (19–23 in-lbs)

S2DM Bodywork

1. Install brake line p-clip.
 - a. Tighten.
Torque: 5–7 N·m (44–62 in-lbs)
2. Install top cover
 - a. Tighten screws.
Torque: 5.9–6.5 N·m (52–58 in-lbs)
3. Install USB cover.

S2MH Bodywork

1. Install trim panel.
 - a. Tighten screws.
Torque: 5.9–6.5 N·m (52–58 in-lbs)
2. Install top cover
 - a. Tighten top screw.
Torque: 5.9–6.5 N·m (52–58 in-lbs)

- b. Tighten side screws.
Torque: 12.9–14.2 N·m (114–126 **in-lbs**)
- 3. Install right battery top cover.
 - a. Torque screws.
Torque: 12.9–14.2 N·m (114–126 **in-lbs**)

COMPLETE

- 1. Remove lockout cover.
- 2. Install fuse.
Current: 40 A
- 3. Stow fuse block in rear caddy.
- 4. Install seat.
 - a. Tighten screws.
Torque: 7–9 N·m (62–80 **in-lbs**)
- 5. Update software.
- 6. Connect Digital Technician II (DT II).
- 7. Navigate to the Reflash menu.
- 8. Update all available modules software highlighted in red.
- 9. Check and clear any Diagnostic Trouble Codes (DTCs).

Credit Procedure

NOTE

Enter bulletin number into comment section of claim.

Submit a warranty claim per Table 5.

Table 5. 2024 S2 High Voltage Fuse

ITEM	DATA
Claim Type	Recall
Customer Concern Code	1003
Condition Code	9981
Labor Code (EMEA Only)	9516
Problem Part Number	69202816
Replacement Part Number	91500118
Quantity	1
Model	GCY, GDY
Model Year	2024
Labor Time	1.5 hours

Return Parts

Hold all claimed parts for 60 days from date of credit issued for possible field inspection and/or request to return to factory. After 60 days, destroy and discard the parts.