



# SAFETY RECALL

— Confidential and Proprietary —

Release Date: July 26, 2024

# IND

Communication #: I-24-07

Expiration Date: No Expiration Date

Model Year(s): 2024

**VERSION: R02 (August 02, 2024)**

## IMPORTANT STOP SALE SAFETY NOTICE!

**Stop selling affected vehicles immediately until the repair procedure has been completed on affected units at your dealership. Federal law prohibits the sale of products subject to a recall. Selling such products could subject the seller to substantial penalties.**

### IMPORTANT

If you are working with a printed copy, please verify you have the most current version of this document.

| Revision | Release Date | Update                               |
|----------|--------------|--------------------------------------|
| R01      | 7/26/2024    | Initial Stop Sale Release            |
| R02      | 8/02/2024    | Stop Sale converted to Safety Recall |

## SUBJECT: HEAVYWEIGHT SHOCK PUSHROD

### REASON FOR THIS RECALL

Indian Motorcycle has determined that some Model Year 2024 Chieftain, Roadmaster, Springfield, Challenger, and Pursuit motorcycles may have been produced with a rear suspension pushrod, which does not meet design specifications. The rear suspension pushrod may buckle under load, which can result in pinching the main chassis harness, damage to the coolant reservoir, damage to the rear tire, or the rear of the motorcycle bottoming out under load, increasing the risk of a crash and serious injury.

### REMEDY

To address this concern, Indian Motorcycle has released this Safety Recall with instructions to replace the rear suspension pushrod.

### DEALER - WHAT TO DO?

As of July 26, 2024, **YOU MUST NOT SELL OR DELIVER** any **NEW OR USED Model Year 2024 Chieftain, Roadmaster, Springfield, Challenger, or Pursuit** affected by this **Stop Sale** until it is repaired according to the **Safety Recall**.

# POLARIS ADVENTURES OUTFITTERS - WHAT TO DO?

Outfitters should make arrangements to have affected vehicles repaired according to the Safety Recall as soon as possible and prioritize non-affected vehicles for rental use.

## QUICK REFERENCE TABLE

Reference the table below for details related to this Safety Recall and some of the requirements.

| NOTICE  |  |
|---|--|
| For additional reference information not included in the document, click <a href="#">HERE</a> |  |

|                                      |   |
|--------------------------------------|---|
| <b>Parts Availability</b>            | In stock and available to order   |
| <b>Parts Ordering</b>                | <input checked="" type="checkbox"/> Standard Parts Order                |
| <b>Parts Destruction or Disposal</b> | See <b>Supplemental Information</b> section at the end of this document |
| <b>Required Special Tools</b>        | NA  |
| <b>Claim Submission Type</b>         | Standard  |

| ITEM  | REQUIRED?   | LINK / ADDITIONAL INFORMATION |
|---|---|-------------------------------|
| <b>Training Requirement</b>                                   | N   |                               |
| <b>Inspection Required</b>                                    | N   |                               |
| <b>Parts removed during repair to be returned to Polaris?</b> | No, Dispose of parts according to local regulations |                               |
| <b>Are Service Parts Affected?</b>                            | N   |                               |
| <b>Photo Requirements</b>                                     | N   |                               |
| <b>Part Serial Number entry (US/CA only)</b>                  | N   |                               |
| <b>Secondary Technician Audit</b>                             | N   |                               |

## WARRANTY CLAIM INFORMATION

| BULLETIN #                                | DESCRIPTION           | LABOR ALLOWANCE            | PART NUMBER / DESCRIPTION  |
|---|-----------------------|----------------------------|--|
| <b>Challenger, Pursuit</b>                |                       |                            |  |
| I-24-07-AA                                | Replace Shock Pushrod | 1.5 hours<br>(90 minutes)  | 7080138 (QTY 1) Tie, Cable<br>1024226 (QTY 1) Pushrod                                  |
| <b>Chieftain, Roadmaster, Springfield</b> |                       |                            |  |
| I-24-07-BA                                | Replace Shock Pushrod | 2.0 hours<br>(120 minutes) | 7547685 (QTY 1) Nut, Swingarm<br>7080138 (QTY 1) Tie, Cable<br>1024226 (QTY 1) Pushrod |

## AFFECTED MODELS

| MODEL YEAR | MODELS      | AFFECTED RANGE  |
|------------|-------------|---|
| 2024       | Chieftain   | Reference Unit Inquiry on the dealer website or the Service Communications list on the STOP site to look up affected units. |
|            | Springfield |   |
|            | Roadmaster  |   |
|            | Challenger  |   |
|            | Pursuit     |   |

The information contained within this document is confidential and protected by U.S. and international copyright laws, and is the property of Polaris Inc. This document is provided for the sole use of authorized Polaris dealers and distributors. This document is not to be distributed, duplicated, or copied, digitally or otherwise, without the written consent of Polaris Inc.

## REPAIR OVERVIEW

In this procedure, the shock pushrod will be replaced.

### I-24-07-AA CRITICAL STEPS

The following procedure steps are critical to a successful repair:

1. Shock reservoir hose routing and retention.
2. Immediately after removal, mark the old pushrod with an "X" and attach a cable tie to the pushrod to differentiate from the replacement part.
3. Upon installation, verify the snap ring is not bent or damaged and is fully seated in the groove.

### I-24-07-BA CRITICAL STEPS

The following procedure steps are critical to a successful repair:

1. Do not allow the VCM to contact the positive battery terminal.
2. Immediately after removal, mark the old pushrod with an "X" and attach a cable tie to the pushrod to differentiate from the replacement part.
3. Removal and installation of the swingarm.
4. Do not loosen adjusters during swingarm removal.
5. Replace the swingarm nut with a NEW one.
6. Upon installation, verify the snap ring is not bent or damaged and is fully seated in the groove.
7. Reference the Service Manual for instructions on wheel alignment and setting the correct belt tension.

# I-24-07-AA REPAIR PROCEDURE (CHALLENGER / PURSUIT)

## I-24-07-AA: TOOLS REQUIRED

- Pliers, Side Cutting
- Pliers, Snap Ring
- M6 x 1.0 fastener, minimum 13mm length
- Socket Set, Metric
  - Socket Size: 10, 17, 18 mm
- Allen Socket Set, Metric
  - Socket Size: 5, 6, 8 mm
- Socket Set, Torx® Bit
  - Socket Size: T40, 90° T40
- Wrench Set, Metric
  - Wrench Size: 17, 18 mm
- Scissor Jack
- Paint Pen
- Vise, Bench
- Torque Wrench

## VEHICLE PREPARATION

1. Park motorcycle on lift with the front wheel secured in a wheel vise. Place a scissor lift under the mid-pipe and make sure the motorcycle is stable.
2. Turn key or ignition switch to OFF position and remove key. If equipped with keyless fob, remove fob from proximity of vehicle.
3. Cover the fuel tank with a protective cloth to prevent damage.

## UPPER SIDE COVER REMOVAL

- Remove right and left-side upper cover ②.

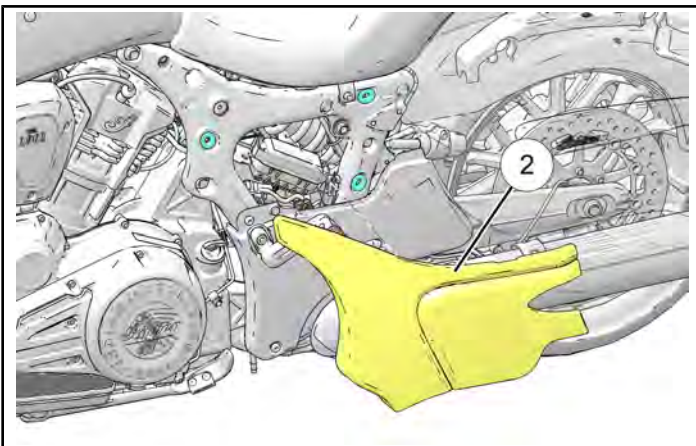

## SADDLEBAG REMOVAL (IF EQUIPPED)

1. Disconnect saddle bag electrical connector ①.

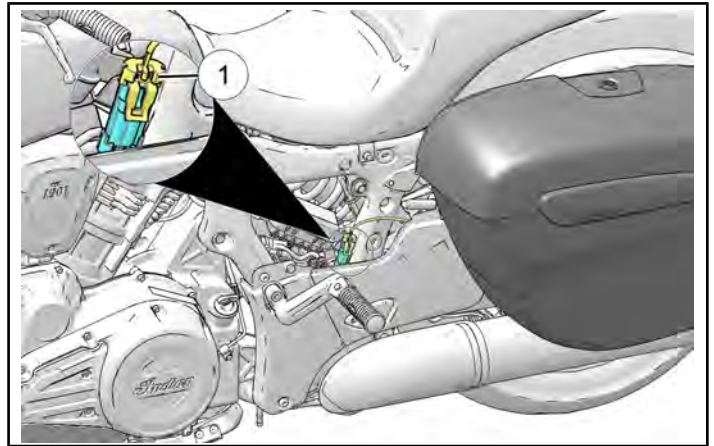

2. Open saddle bag lid.
3. Remove saddlebag by removing its fasteners ②.

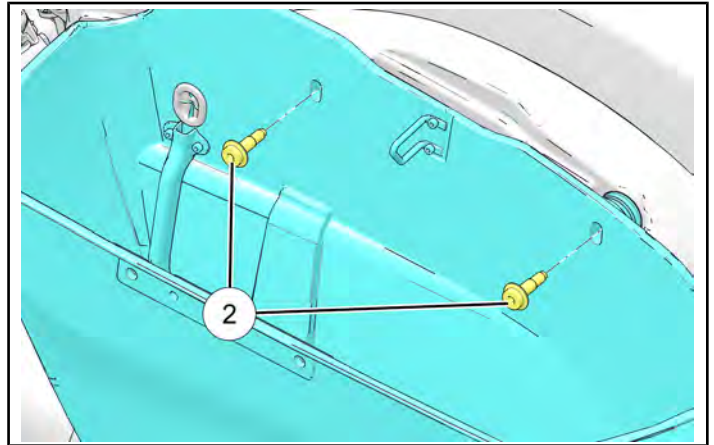

## TRUNK REMOVAL (IF EQUIPPED)

1. Remove the trunk lock fastener ① from each trunk latch.

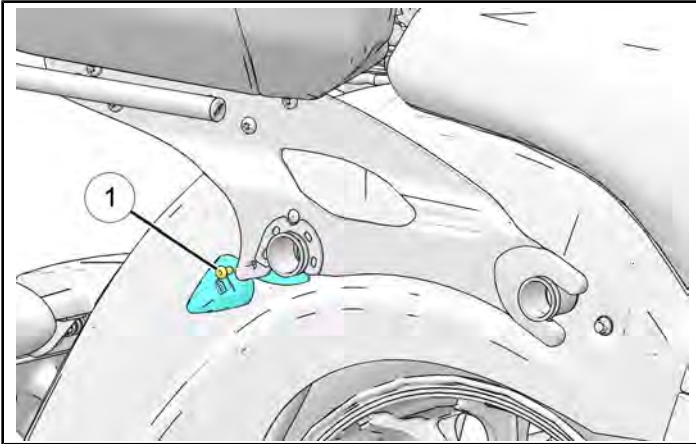

2. Disconnect the trunk harness ② and the antenna connector ③.

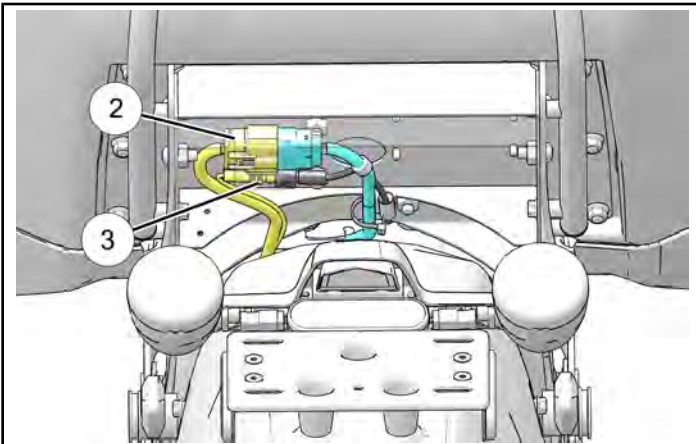

3. Lift the trunk latches ④ to unlock the trunk from the mount.

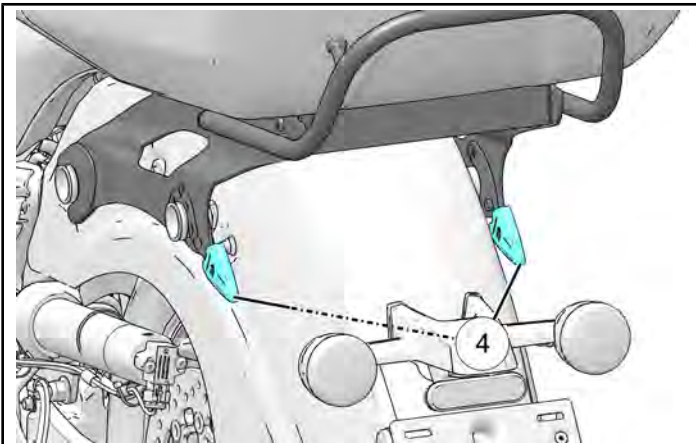

4. Lift up on the rear of the trunk and slide rearward to release the trunk from the motorcycle.

## SEAT REMOVAL

1. Remove seat fastener ①.

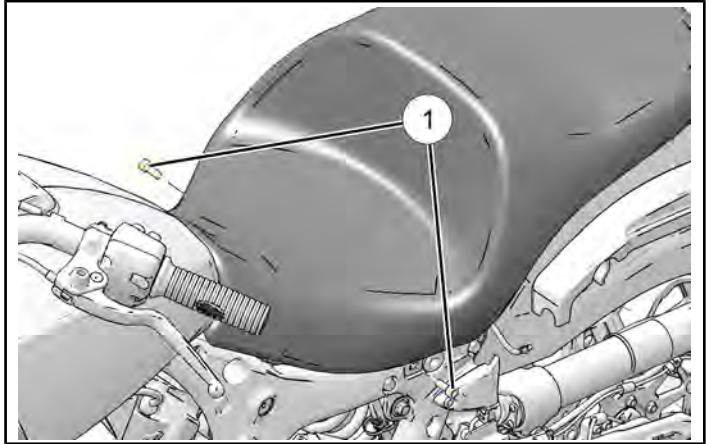

2. Disconnect seat electrical connector (if equipped).

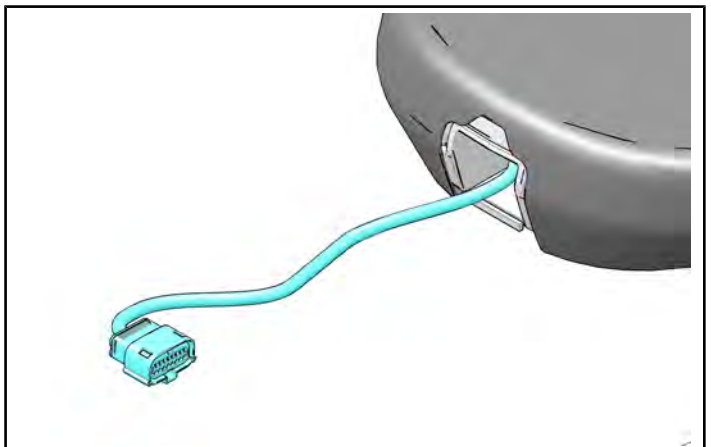

3. Remove the seat backward and up to remove.

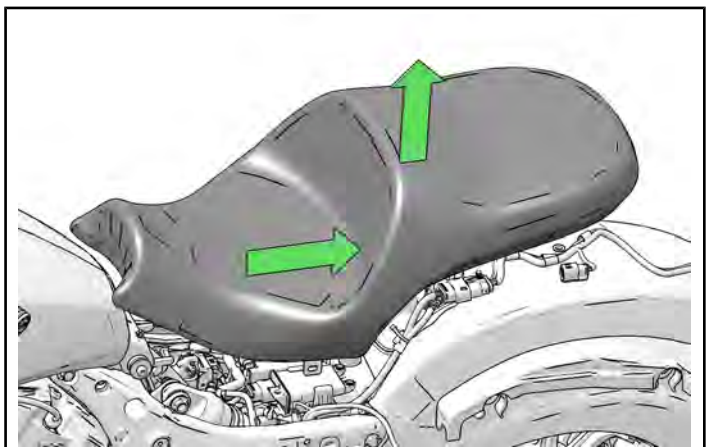

### ⚠ CAUTION

Use care not to damage wires that are routed through the seat on some models.

## LOWER SIDE COVER REMOVAL

1. Remove left-hand rear highway bar fasteners ④ and bar. (if equipped).

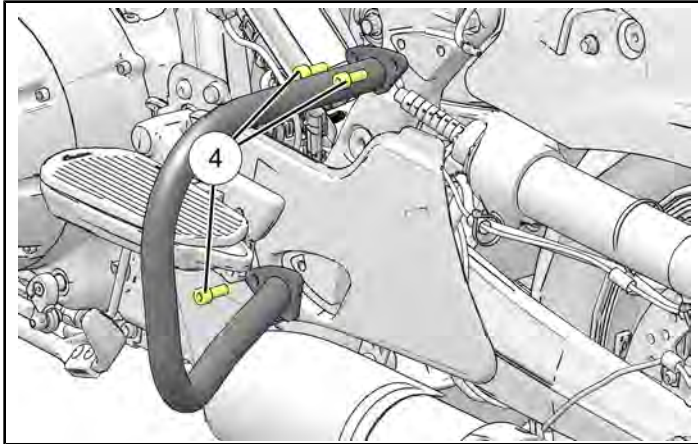

2. Remove passenger floorboard or footpeg mount by removing the plug ② and fastener ③.

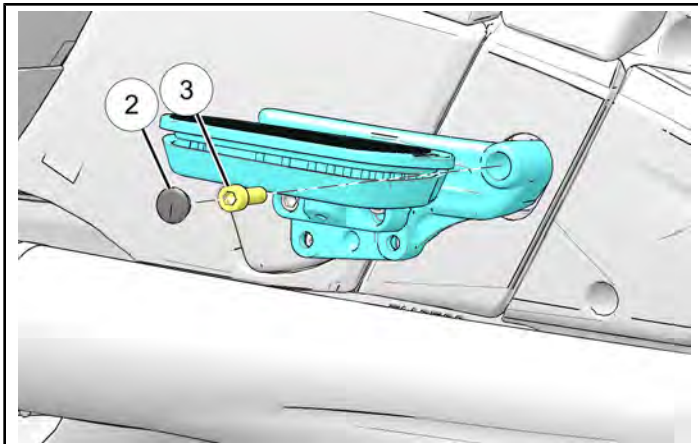

3. Remove fasteners ⑤ and ⑥. Remove left-hand lower cover.

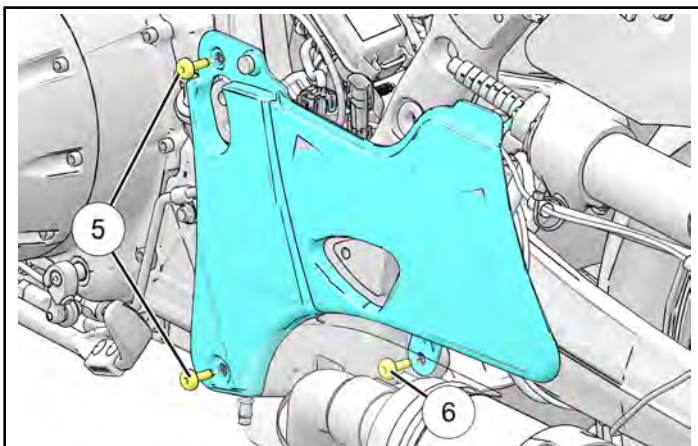

### NOTICE

The bottom rear fastener ⑥ located behind the exhaust requires 90° Torx socket.

4. Disconnect the E-Preload Harness, (if equipped).

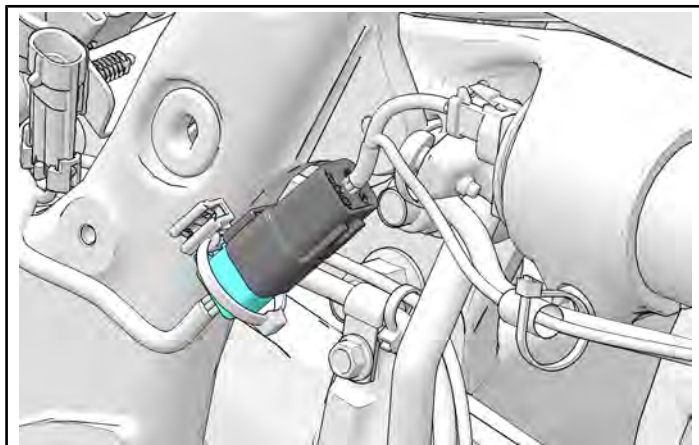

## I-24-07-AA: SHOCK PUSHROD REMOVAL (CHALLENGER / PURSUIT)

1. Place scissor lift under the motorcycle to take the weight off the suspension.

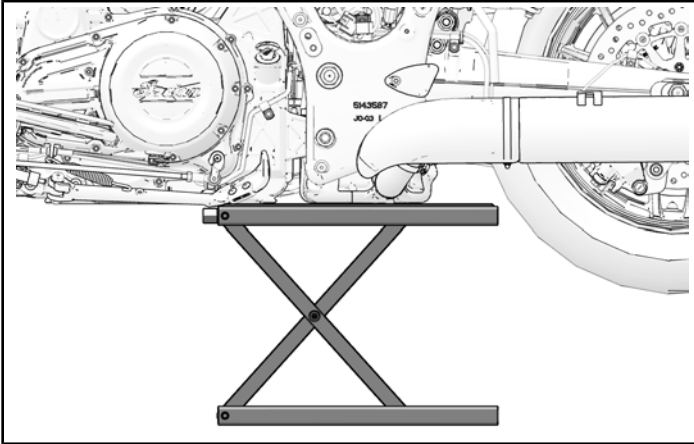

### ⚠ CAUTION

Make sure the motorcycle is stable and secured before moving to the next step.

2. Using a snap ring pliers, remove the snap ring ①.

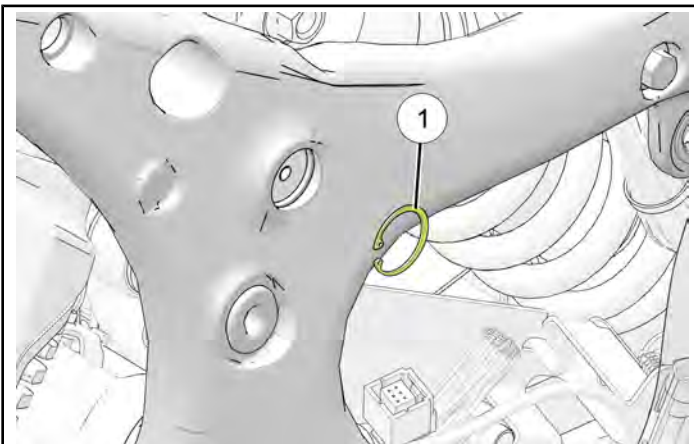

### ⚠ CAUTION

Do not use a screwdriver or pry on snap ring as damage may occur.

3. Insert a M6 x 1.00 fastener (not provided) into the shock pin that secures the rear shock linkage to the frame.

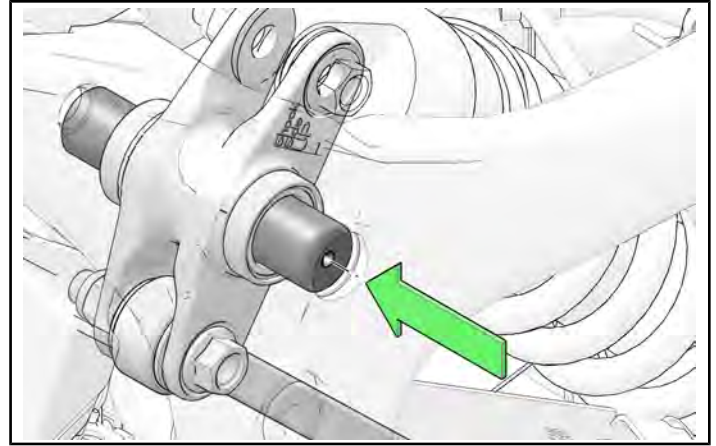

4. Remove the shock pin ②.

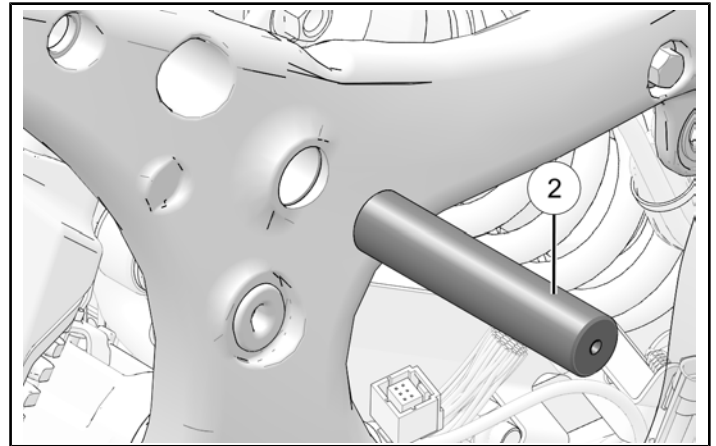

### NOTICE

Raise or lower the scissor lift until the tension is free of the shock pin and remove.

5. Remove the shock top mounting fastener ⑤.

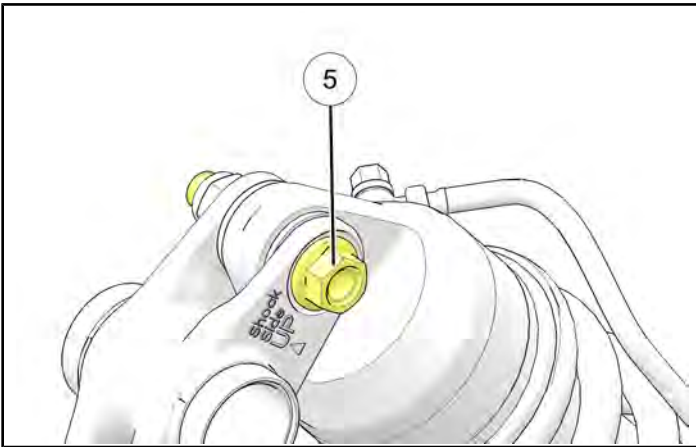

**IMPORTANT**

Make note of the direction the top and bottom fastener positioned in the shock for installation.

6. Raise the scissor lift high enough to gain access to the lower shock fastener. Remove the shock bottom mounting fastener ⑥.

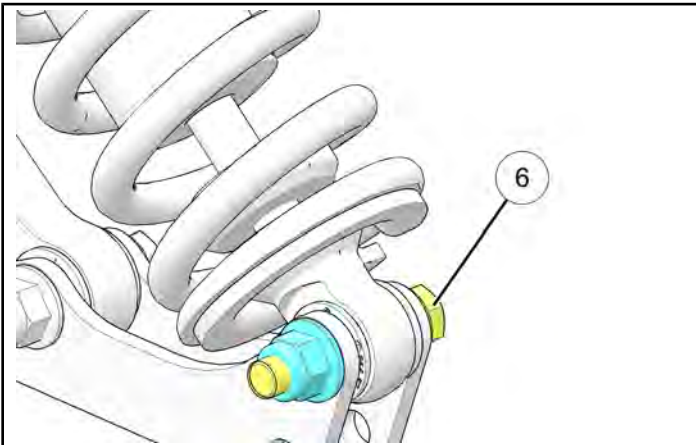

**IMPORTANT**

Note the direction of the fastener for installation.

7. Disconnect shock reservoir.

• **Non E-Preload Models:**

a. Cut two cable ties securing the shock reservoir hose to the shock.

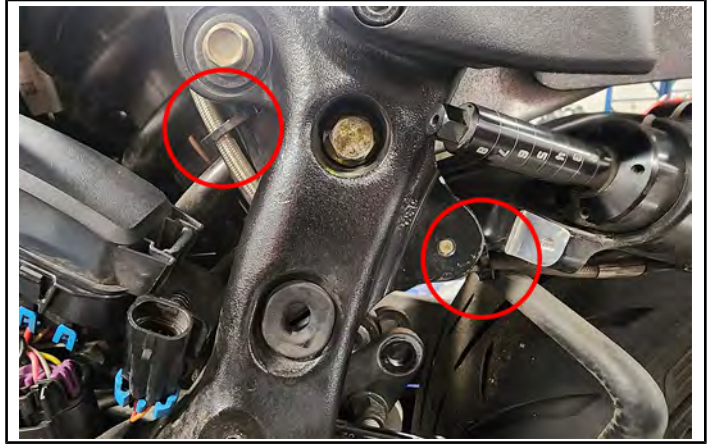

b. Remove reservoir pinch fastener ⑦.

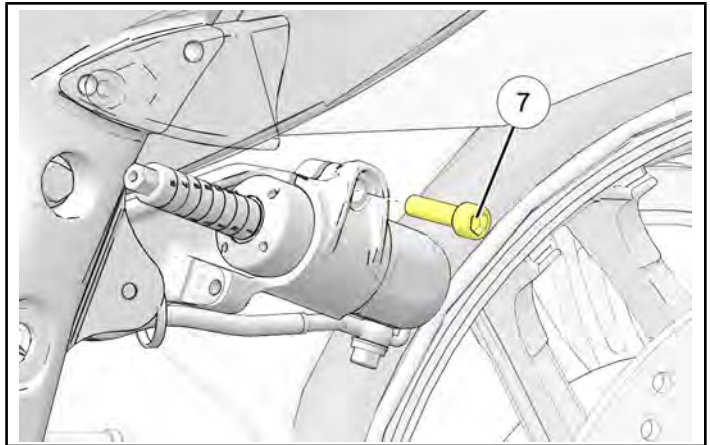

• **E-Preload Models:**

a. Cut and remove two cable ties securing the shock reservoir hose to the bracket.

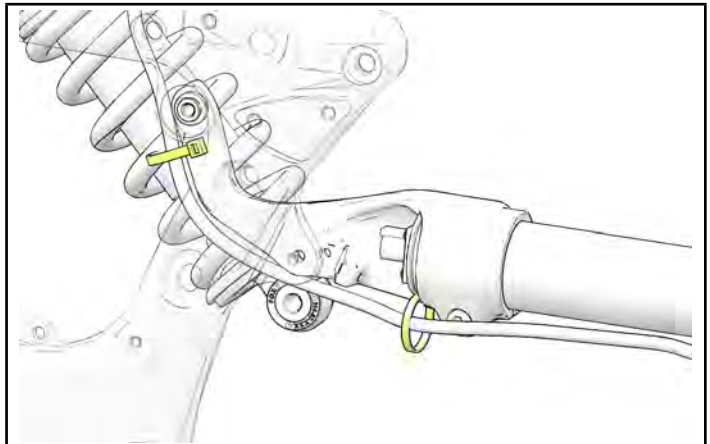

- b. Disconnect shock electrical connectors ①. Cut and remove cable ties ②.

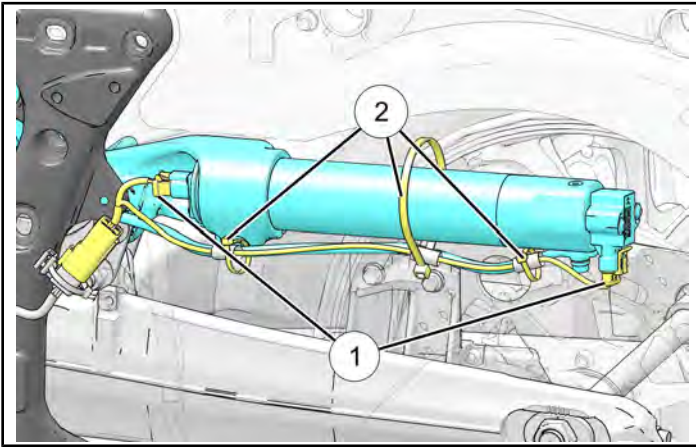

**⚠ CAUTION**

Do not use anything other than fingers to remove electrical connectors. The use of tools can damage the connection.

- c. Remove reservoir pinch fastener ⑦.

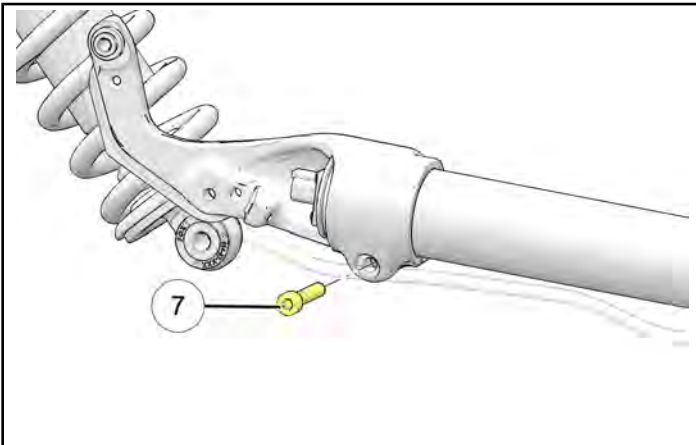

8. Support the reservoir during removal. Position shock and reservoir up through the seat area and remove from the motorcycle.

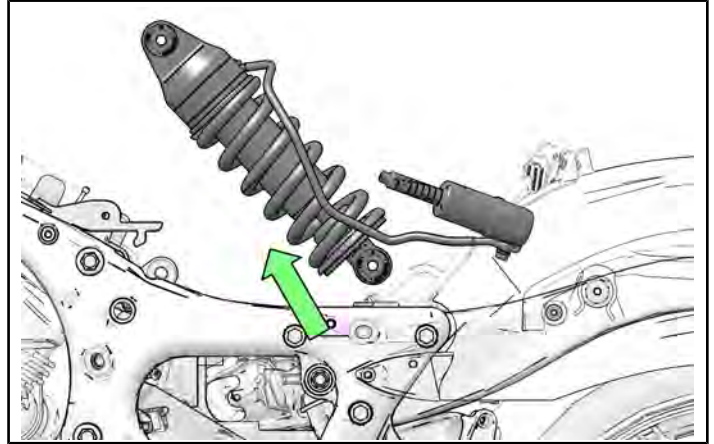

**⚠ CAUTION**

Do not allow the reservoir to hang from the shock.

9. Remove fasteners ② securing the fuse box plate to the casting.

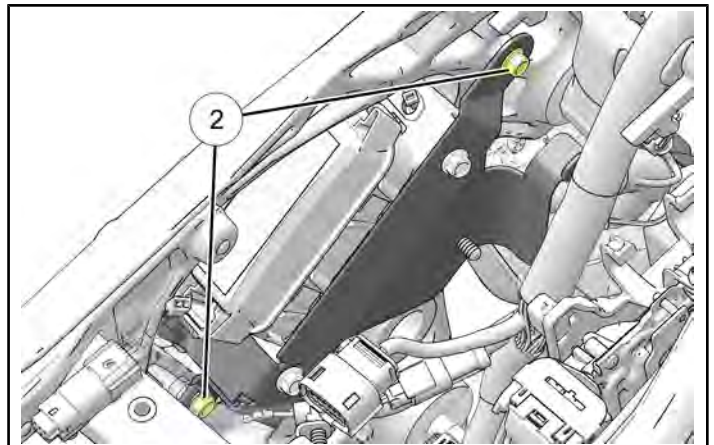

10. Move the fuse box up, and raise the rear of the motorcycle to access the front of the lower pushrod mounting fastener ③.

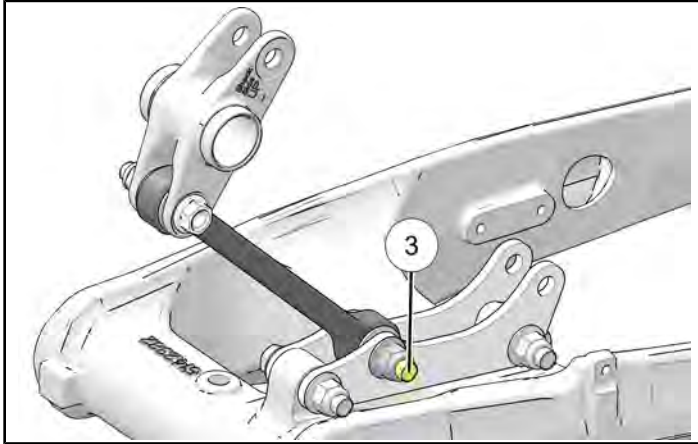

**⚠ CAUTION**  
Do NOT use tools to move the fuse box as damage could occur.

11. Disconnect the wheel speed sensor to allow the lower pushrod mounting fastener to be removed.

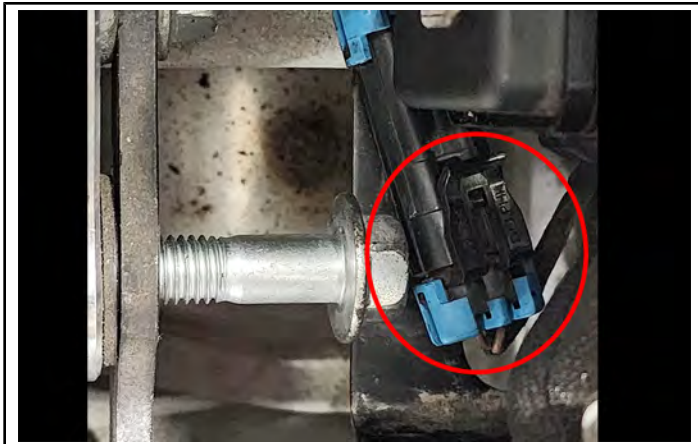

12. Remove the pushrod from the underseat area.

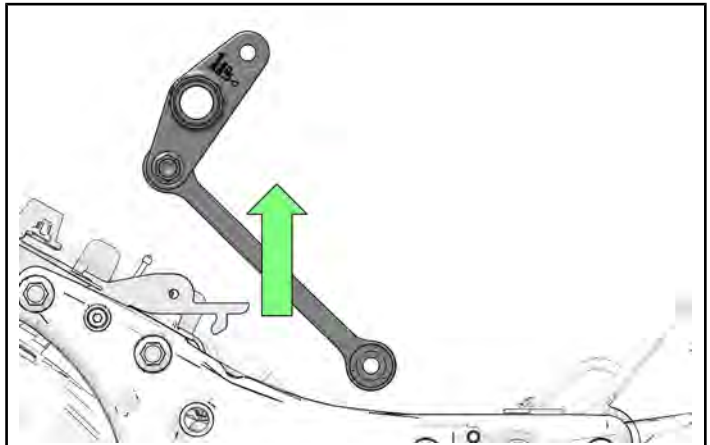

**STOP!**

Loop a cable tie through the lower pushrod hole. Using a paint pen, mark the pushrod with an X.

A technical line drawing of the lower pushrod with a yellow cable tie looped through the hole at its bottom end. A white 'X' is drawn on the side of the pushrod.

13. Secure the pushrod into a bench vise and remove fastener ① and shock top piece.

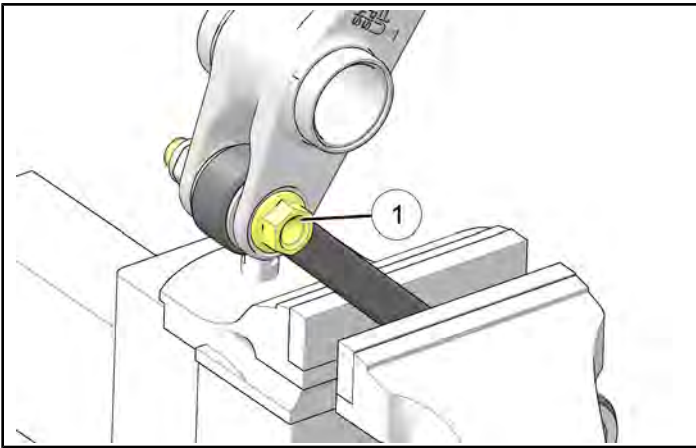

14. Discard the pushrod.



Verify the pushrod being disposed was the marked with an X and has a cable tie looped through one end.

**IMPORTANT**

Make note of the direction the rocker and fastener position for installation.

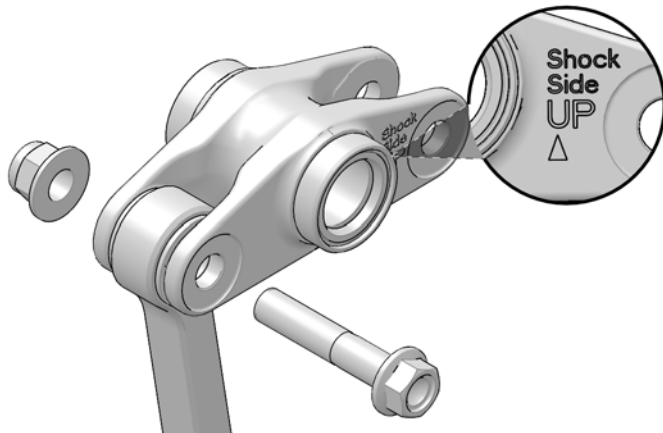

**IMPORTANT**

Note the orientation of the fasteners for installation

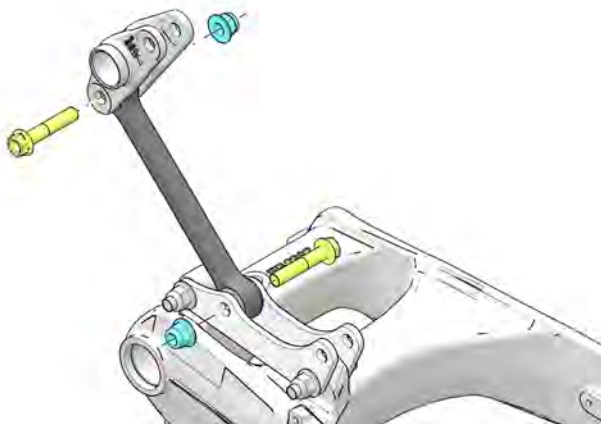

## I-24-07-AA: SHOCK PUSHROD INSTALLATION (CHALLENGER / PURSUIT)

1. Install new pushrod into rocker using vise. Install shock fastener ①. Torque to specification.

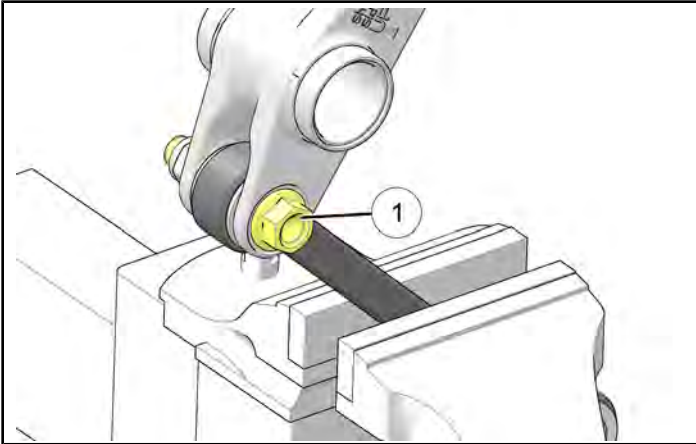

### NOTICE

The shock pushrod is not directional.

### IMPORTANT

Make note of the direction the rocker and fastener position during installation.

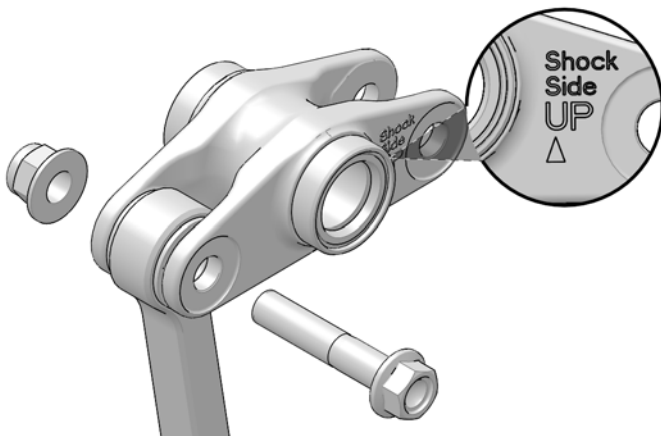

### TORQUE

Shock Fastener:  
**96 ft-lbs (130 N·m)**

2. Install pushrod through underseat area into lower mount. Install lower pushrod fastener ③. Torque to specification.

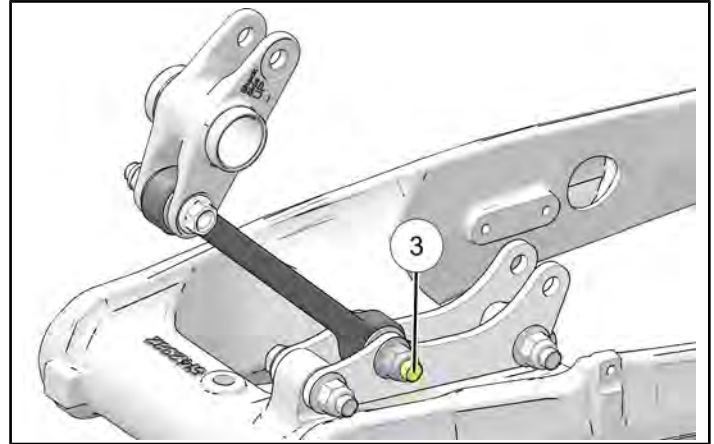

### TORQUE

Shock Fastener:  
**96 ft-lbs (130 N·m)**

3. Connect the wheel speed sensor.

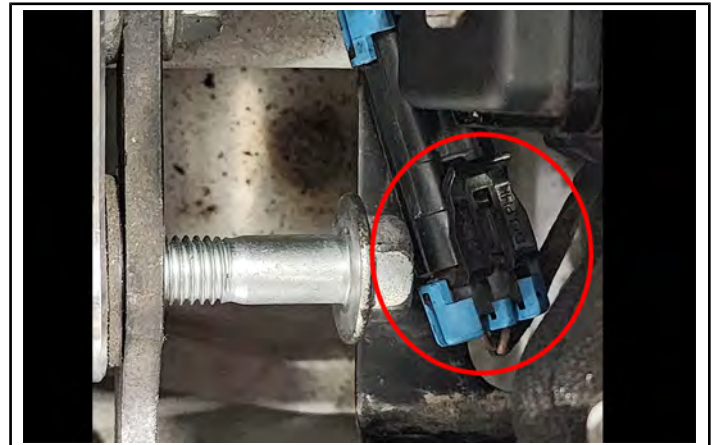

### ⚠ CAUTION

Listen for audible "click" when pressing into place. Pull gently on connector once seated to ensure a proper connection has been made.

4. Secure fuse box with fasteners ②. Torque fasteners to specification.

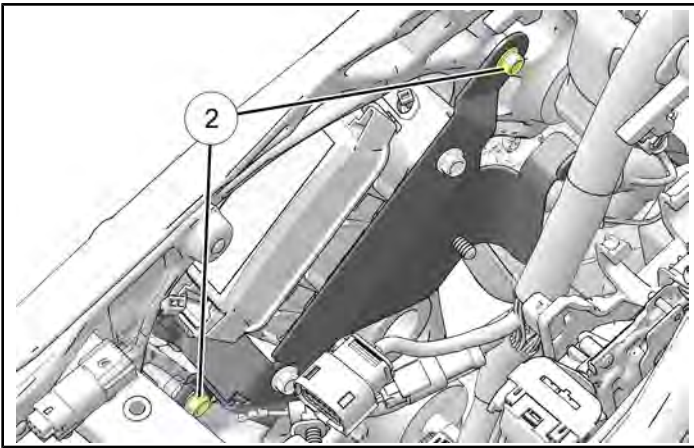

**TORQUE**

Fuse Box Mount Fasteners:  
**88 in-lbs (10 N·m)**

b. Install reservoir pinch fastener ⑦. Torque fastener to specification.

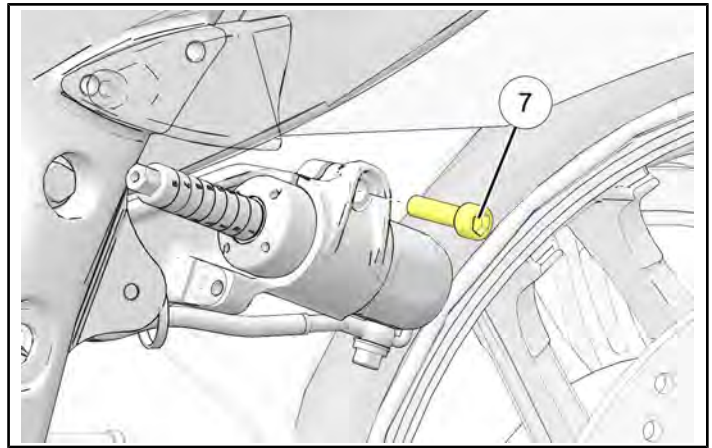

**TORQUE**

Shock Adjuster Fastener:  
**18 ft-lbs (24 N·m)**

5. Install rear shock through underseat area.

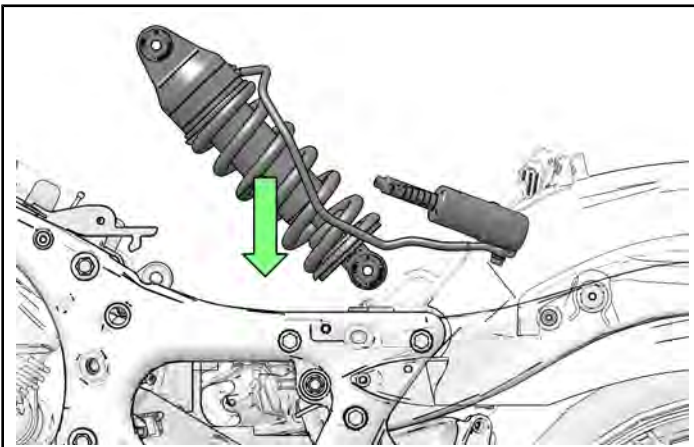

6. Align rear shock and reservoir into mount positions.

• **Non E-Preload Models:**

a. Install two cable ties securing the shock reservoir hose to the reservoir bracket.



• **E-Preload Models:**

a. Install two cable ties securing the shock reservoir hose to the reservoir bracket.

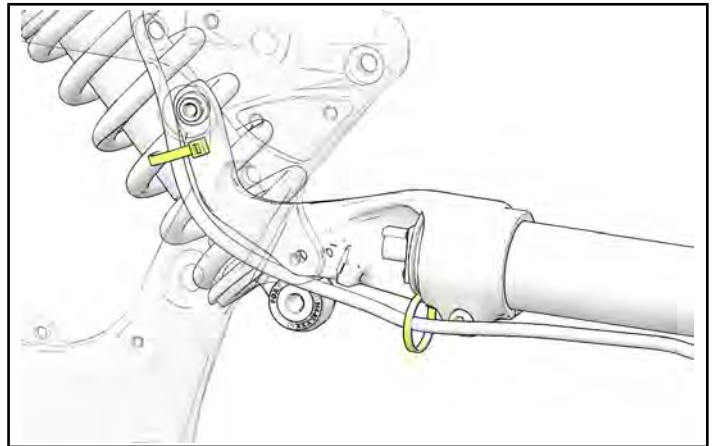

b. Install harness cable ties ②.

c. Connect shock electrical connectors ①.

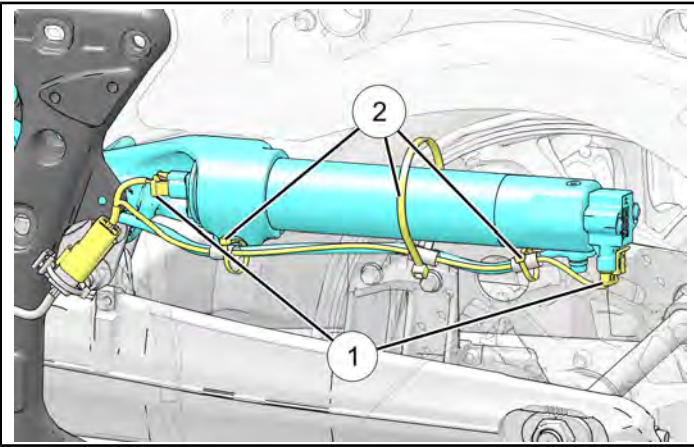

**⚠ CAUTION**

Listen for audible "click" when pressing into place. Pull gently on connector once seated to ensure a proper connection has been made.

d. Install reservoir pinch fastener ⑦. Torque to specification.

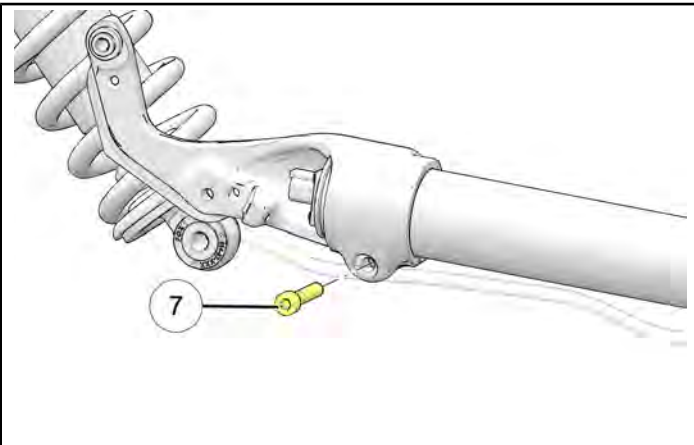

**TORQUE**

Shock Adjuster Fastener:  
**18 ft-lbs (24 N·m)**

8. Install shock fastener ⑥. Torque to specification.

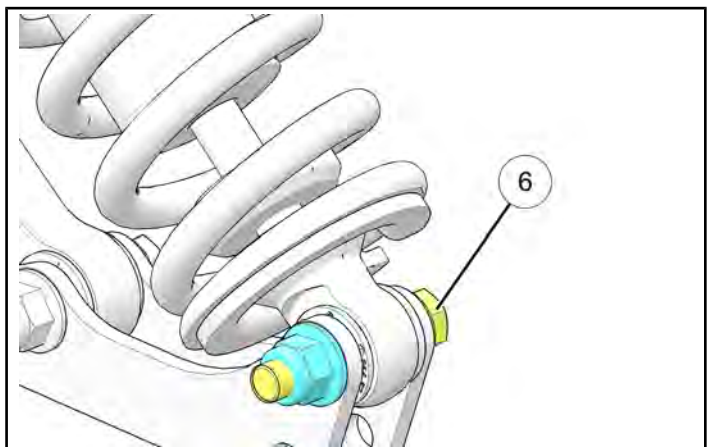

**TORQUE**

Shock Fastener:  
**96 ft-lbs (130 N·m)**

9. Lift the motorcycle if needed and install top shock fastener ⑤. Torque to specification.

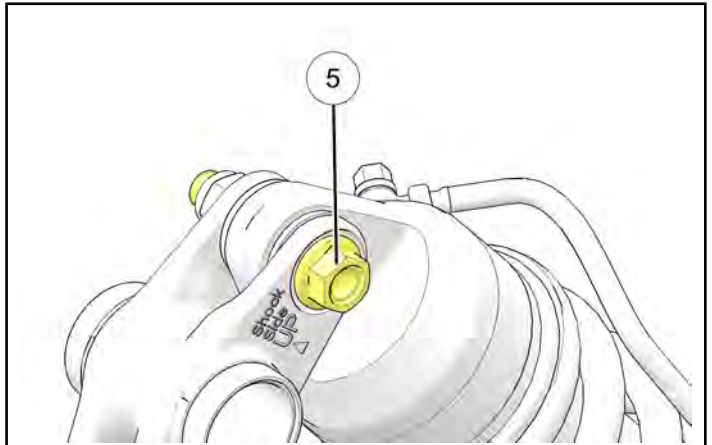

**TORQUE**

Shock Fastener:  
**96 ft-lbs (130 N·m)**

7. Verify the routing and retention points are correct.  
See **page 39**

10. Install shock pin through the rear shock linkage and frame and secure with snap ring.

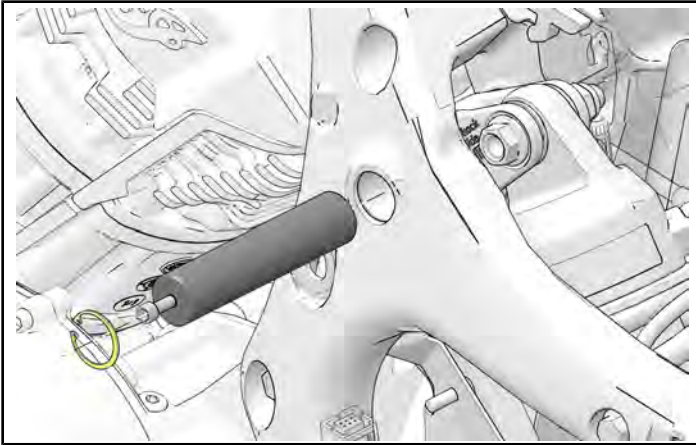

**NOTICE**

Lift/lower rear of the motorcycle to line up shock pin.

**IMPORTANT**

Verify the snap ring is not bent or damaged and is fully seated in the groove. Submit an ASK Polaris case if a new snap ring is required.

11. Remove the M6 x 1.0 fastener from the shock pin.

12. Remove scissor lift.

## FINAL ASSEMBLY

### LOWER SIDE COVER INSTALLATION

1. Install lower cover and connect e-preload (if equipped).
2. Install left-hand rear crash bar (if equipped).
3. Remove lower side cover fasteners ②. Torque fasteners to specification.

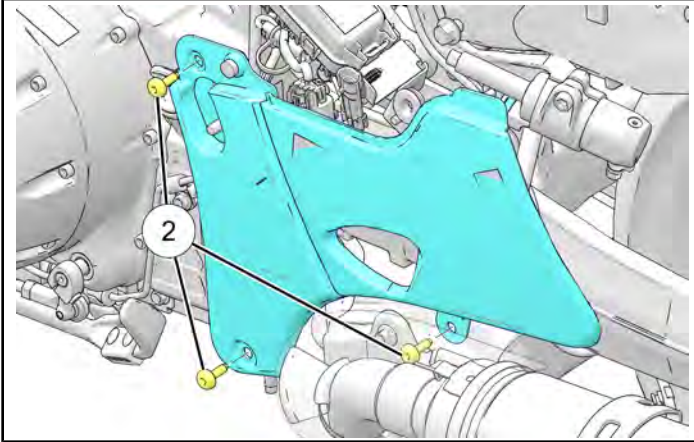

#### NOTICE

The bottom right-hand fasteners requires 90° Torx socket.

#### TORQUE

Lower Side Cover Accent Fasteners  
**88 in-lbs (10 N·m)**

4. Install passenger floorboard or footpeg mount and fastener ③. Torque fastener to specification. Install the plug ②.

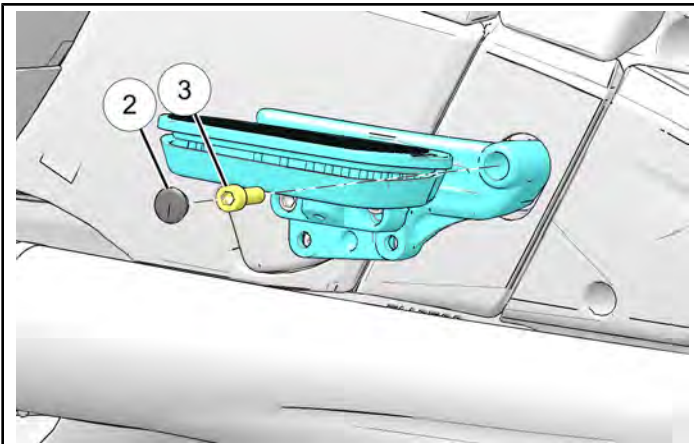

#### TORQUE

Passenger Floorboard or Footpeg Mount Fastener:  
**33 ft-lbs (45 N·m)**

## SEAT INSTALLATION

1. Install the seat.
2. If equipped, connect seat electrical connector.
3. Install seat fasteners ①. Torque fasteners to specification

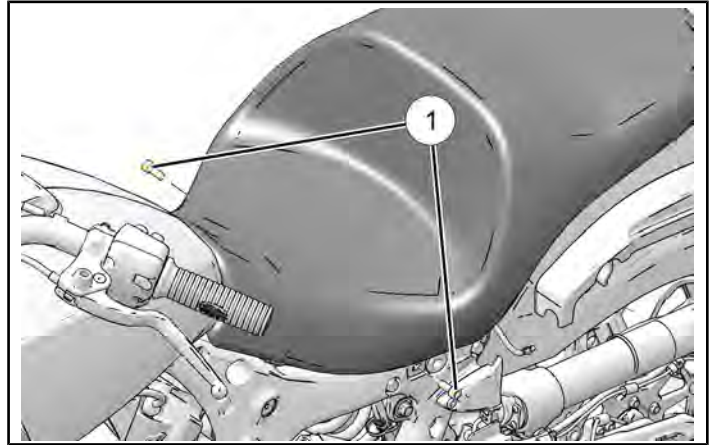

#### TORQUE

Seat Fastener:  
**18 ft-lbs (24 N·m)**

## TRUNK INSTALLATION (IF EQUIPPED)

1. Lift the trunk latches (4) to unlock the trunk from the mount.

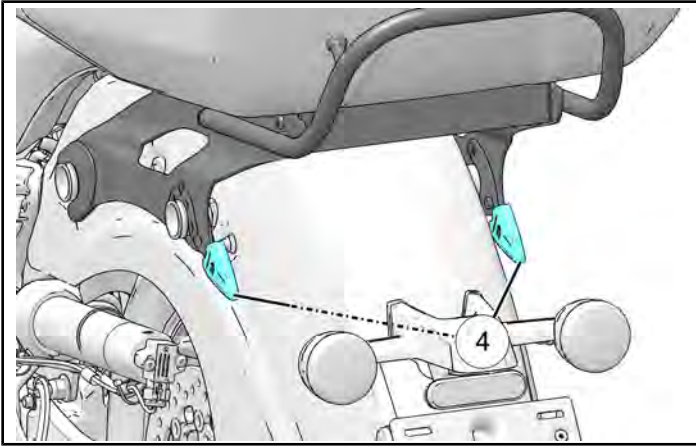

2. Connect the trunk harness (2) and the antenna connector (3).

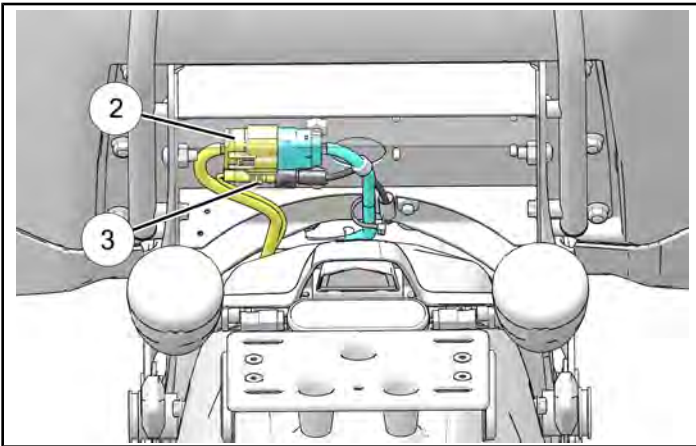

3. Install the trunk lock fastener (1) to each trunk latch. Torque to specification.

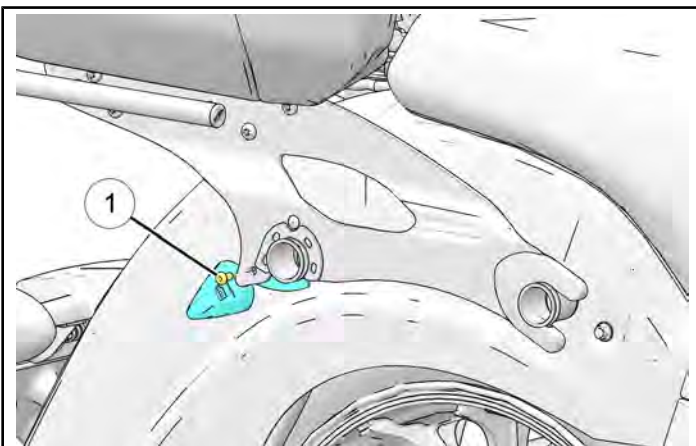

### TORQUE

Trunk Lock Fastener  
12 in-lbs (1 N·m)

## SADDLEBAG INSTALLATION (IF EQUIPPED)

1. Install the saddlebags into position. Install fasteners (2). Torque fasteners to specification.

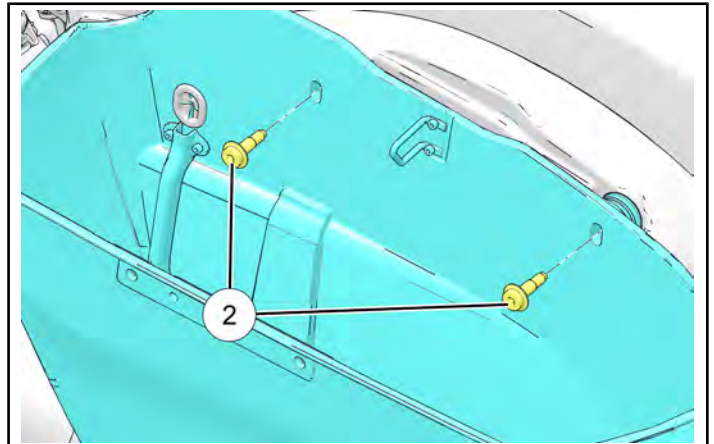

### TORQUE

Saddlebag Fastener:  
18 ft-lbs (24 N·m)

2. Close the saddlebag lid.
3. If applicable, connect saddle bag electrical connector (1).

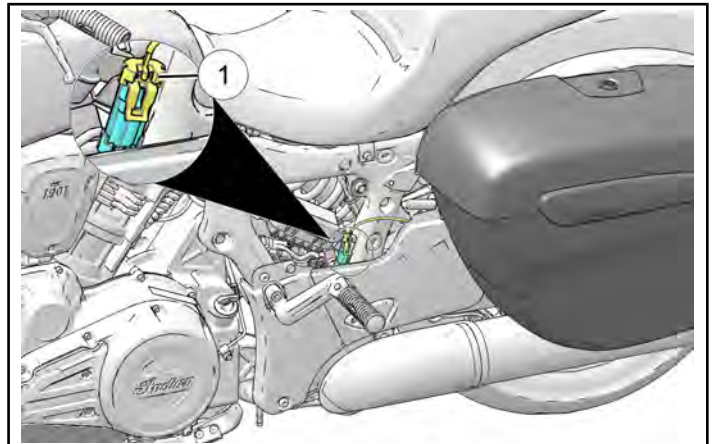

## UPPER SIDE COVER INSTALLATION

1. Install left and right-side upper side covers ②.

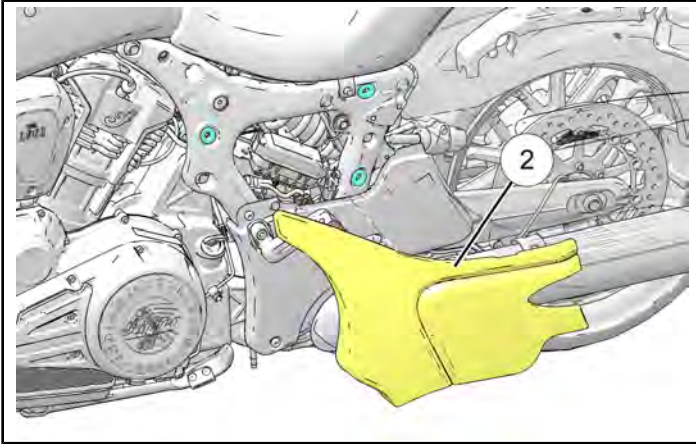

2. Power on motorcycle and check for MIL lights.

## SUBMITTING A CLAIM

1. Submit a Service Bulletin Warranty Claim for I-24-07-AA.

# I-24-07-BA REPAIR PROCEDURE (CHIEFTAIN / ROADMASTER / SPRINGFIELD)

## I-24-07-BA: TOOLS REQUIRED

- Pliers, Side Cutting
- Pliers, Snap Ring
- M6 x 1.0 fastener, minimum 13mm length
- Socket Set, Metric
  - Socket Size: 8, 10, 13, 15, 18, 22, 27, 32 mm
- Allen Socket Set, Metric
  - Socket Size: 5, 6, 8 mm
- Socket Set, Torx® Bit
  - Socket Size: T40
- Wrench Set, Metric
  - Wrench Size: 10, 18 mm
- Paint Pen
- Rubber Mallet
- Scissor Jack
- Torque Wrench

## VEHICLE PREPARATION

1. Park motorcycle on lift with the front wheel secured in a wheel vise. Place a scissor lift under the mid-pipe and make sure the motorcycle is stable.
2. Turn key or ignition switch to OFF position and remove key. If equipped with keyless fob, remove fob from proximity of vehicle.
3. Cover the fuel tank with a protective cloth to prevent damage.

## UPPER SIDE COVER REMOVAL

- Working from the right side of the motorcycle, pull corners of the upper cover evenly straight outward to disengage each tab from rubber grommet in frame.

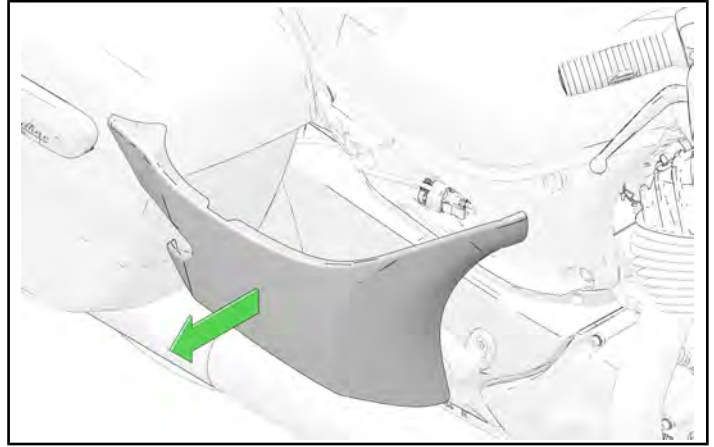

- Working from the left hand side of the motorcycle, pull corners of the upper cover evenly straight outward to disengage each tab from rubber grommet in frame.

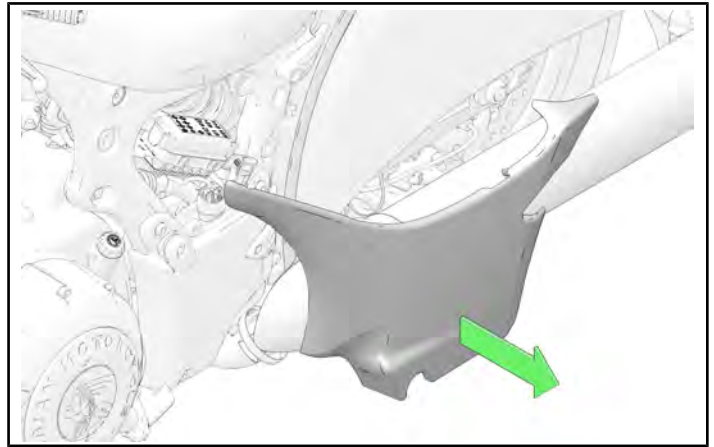

## SADDLEBAG REMOVAL (IF EQUIPPED)

1. Unlock the electric saddlebag locks (if equipped).

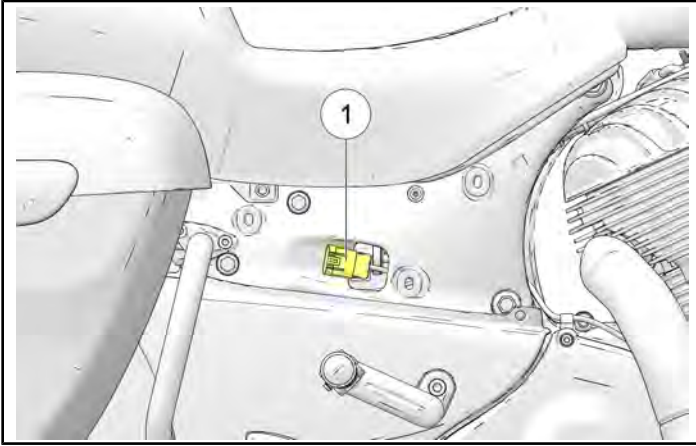

2. Disconnect the saddlebag lock wiring near the seat (1).
3. Press the lid latch release button and lift the lid.
4. Remove the saddlebag fastener bolts (2).

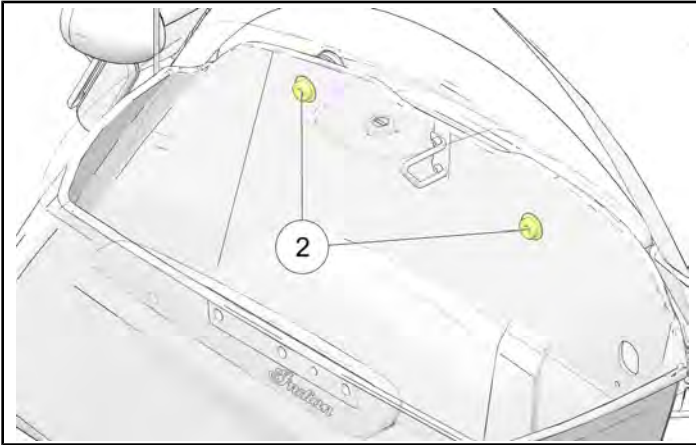

5. Tilt the saddlebag away from the frame of the vehicle to remove it.

## TRUNK REMOVAL (IF EQUIPPED)

1. If applicable, remove the left and right saddlebags and remove the trunk lock fastener (1) from each trunk latch.

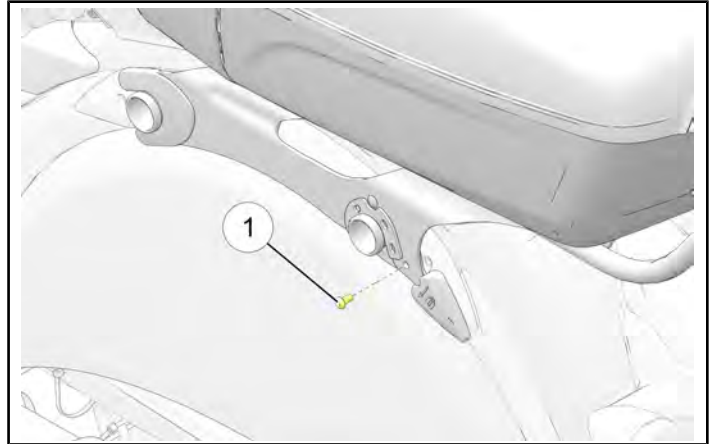

2. Disconnect the trunk harness multi-plug (2).

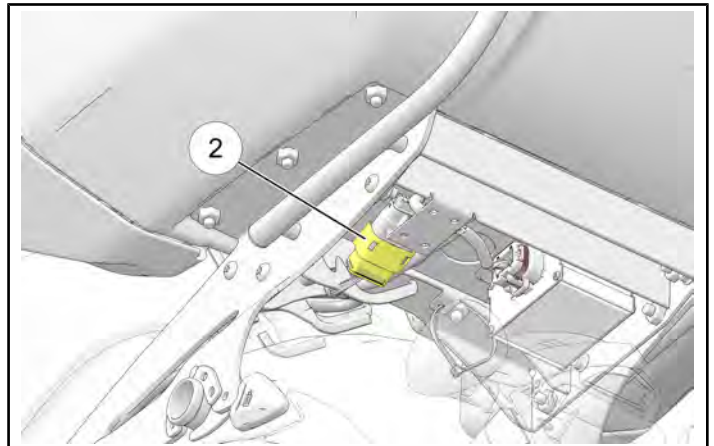

3. Lift the trunk latches (3) to unlock the trunk from the mount.

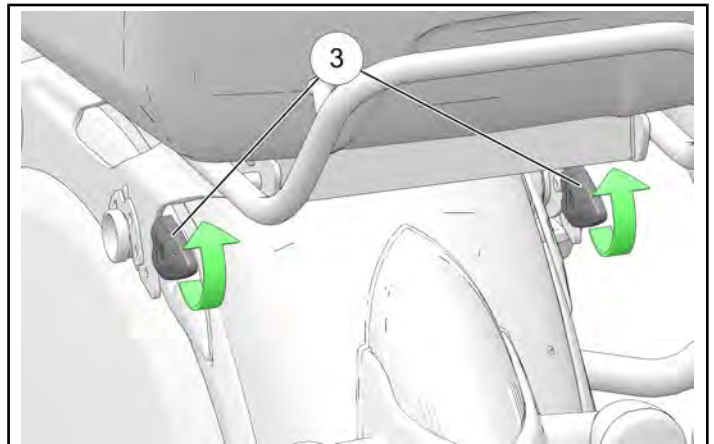

4. Lift up on the rear of the trunk ④ and slide rearward ⑤ to release the trunk from the motorcycle.

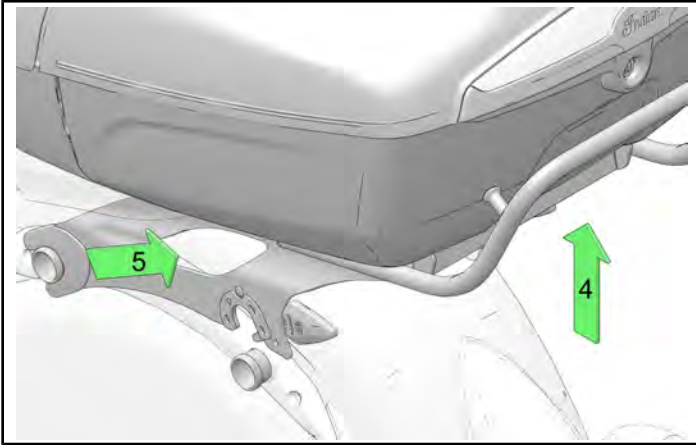

## SEAT REMOVAL

1. Using a 6 mm hex wrench, remove the two fasteners ① securing the driver's seat to the frame.

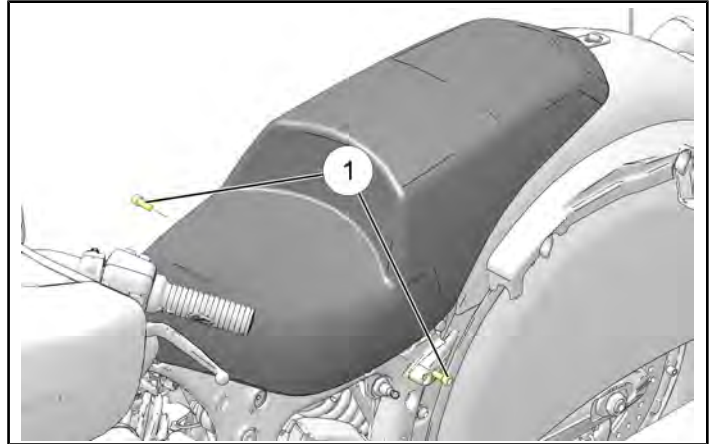

### NOTICE

It may be necessary to lift the seat skirt to access the side fasteners on some models.

2. Remove the passenger seat fastener ② and washer.

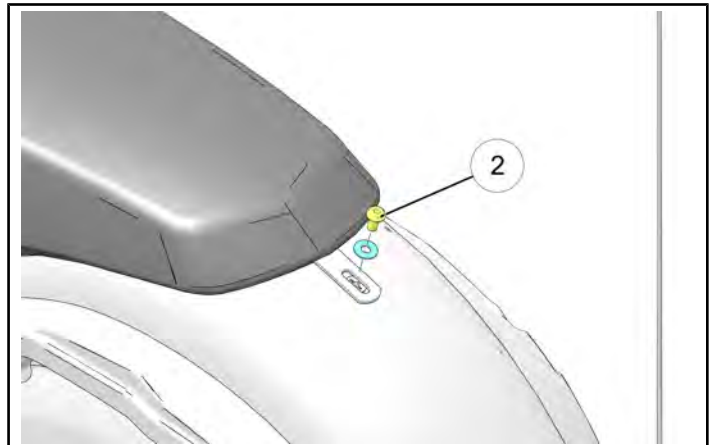

3. Lift the rear of the seat and pull rearward to disengage front retaining arms from the bracket behind the fuel tank.

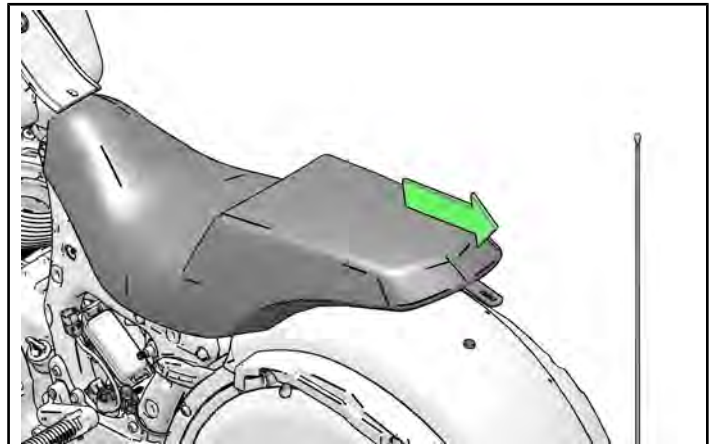

## LOWER SIDE COVER REMOVAL

1. Pull the rear edge of the right-hand lower side panel straight out to disengage the two rubber grommets ①.

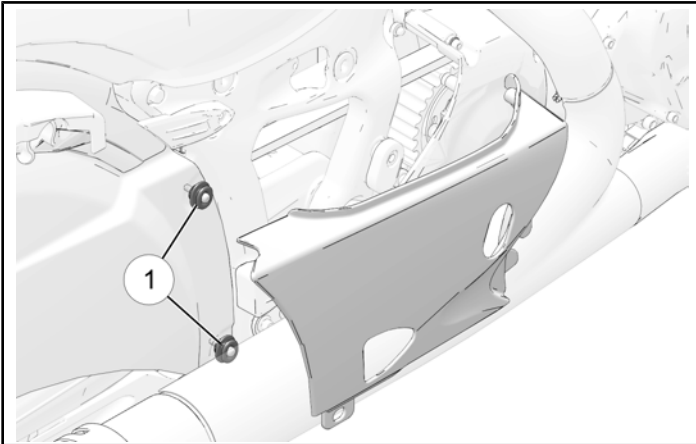

2. Pull back slightly on the right-hand lower side panel to disengage from the front rubber grommet.
3. Working from the left-hand side of the motorcycle, use a 6 mm hex wrench to remove the three fasteners ② securing the panel to the frame. Remove panel.

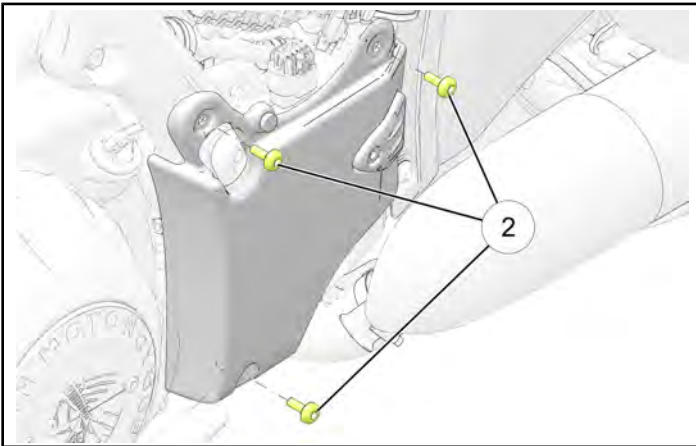

## I-24-07-BA: SHOCK PUSHROD REMOVAL (CHIEFTAIN / ROADMASTER / SPRINGFIELD)

1. Place scissor lift under the motorcycle to take the weight off the suspension.

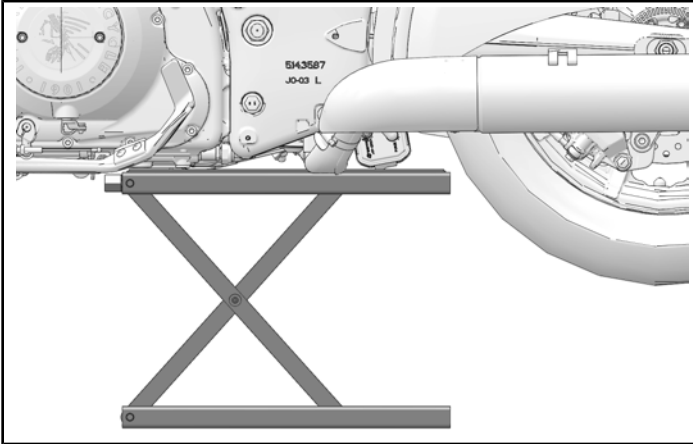

### ⚠ CAUTION

Make sure the motorcycle is stable and secured before moving to the next step.

2. Remove the fastener ① securing the VCM mounting plate to the battery box. Slide the VCM tray toward the front of the motorcycle to disengage with battery box tabs.

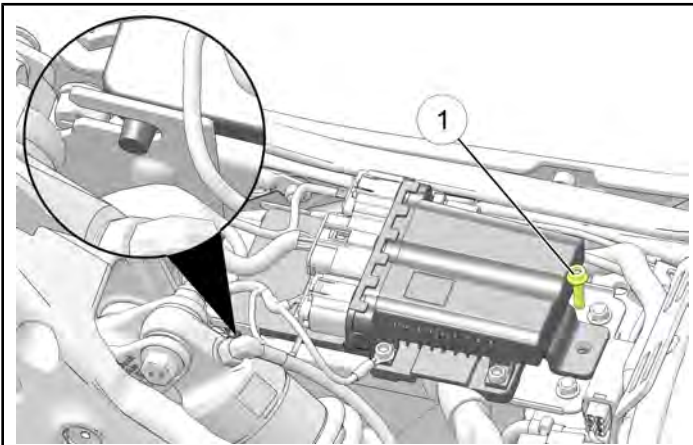

### ⚠ CAUTION

Do not allow VCM to contact the positive battery terminal.

3. Remove negative (-) battery terminal fastener and cable first.

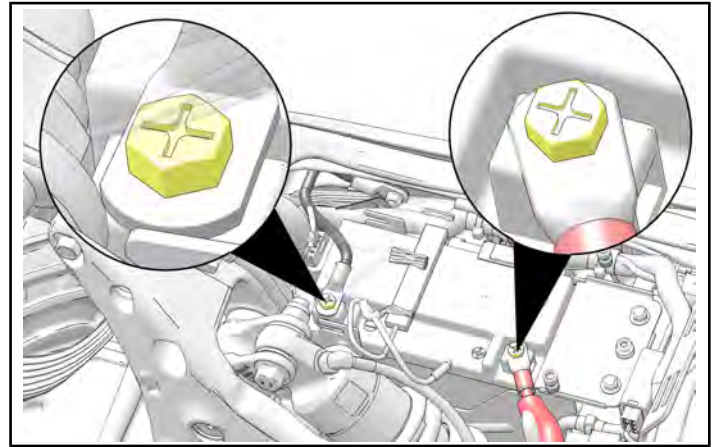

4. Remove positive (+) battery terminal fastener and cable last.
5. Cover negative (-) and positive (+) terminals with electrical tape to prevent incidental contact with the VCM.
6. Remove nut ③ securing the shock air hose to the frame.

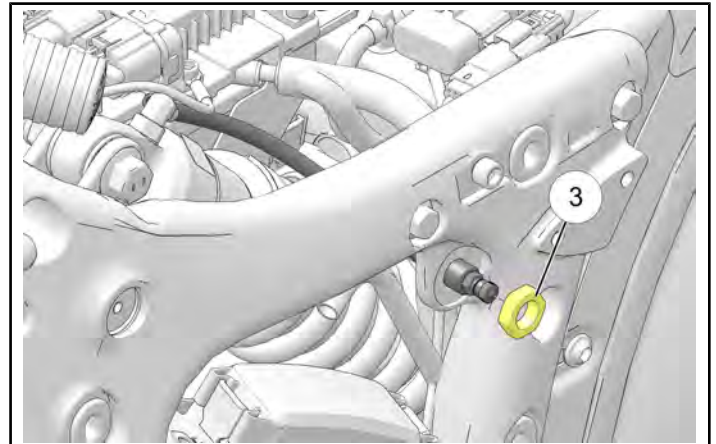

7. Using a snap ring pliers, remove the snap ring ⑬.

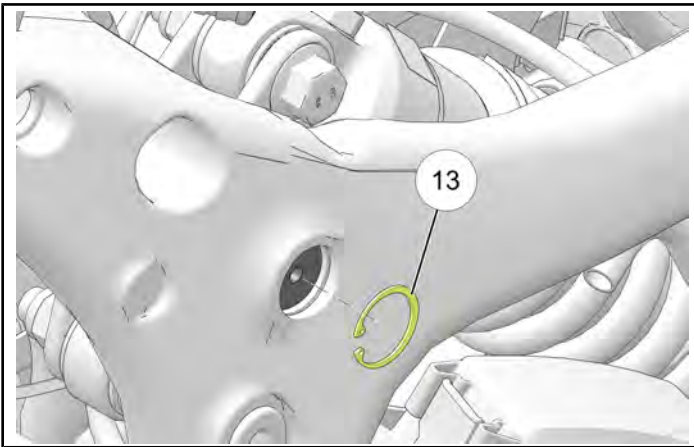

**CAUTION**

Do not use a screwdriver or pry on snap ring as damage may occur.

8. Insert a M6 x 1.0 fastener (not provided) into the shock pin that secures the rear shock linkage to the frame.

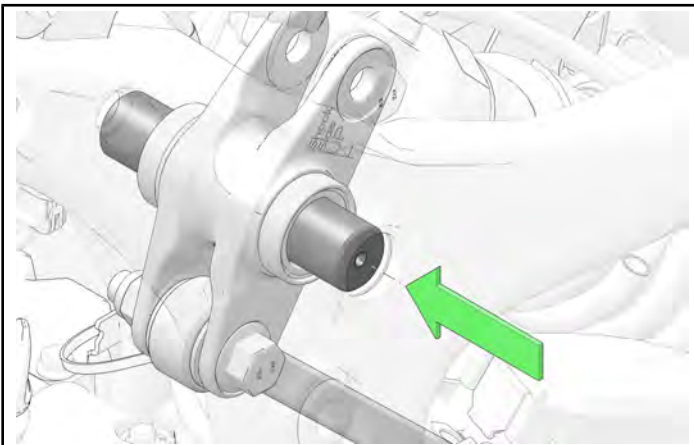

9. Remove the shock pin ⑭.

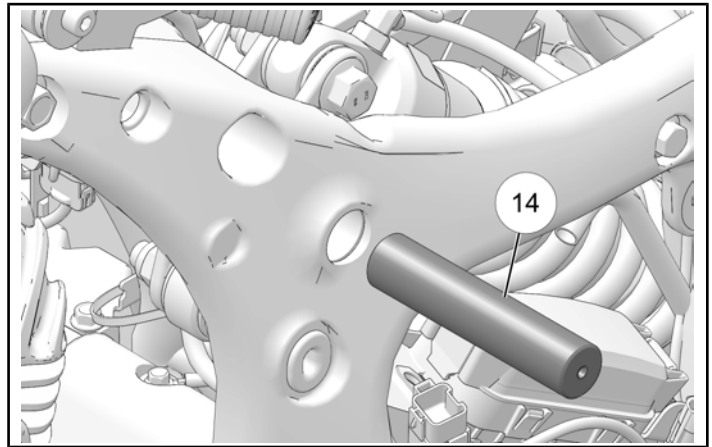

**NOTICE**

Raise or lower the scissor lift until the tension is free of the pin and remove.

**IMPORTANT**

Second technician must hold the swingarm while removing pivot.

10. On both sides, Loosen clamp ④, mounting fasteners ⑤, and remove the left and right-hand muffler.

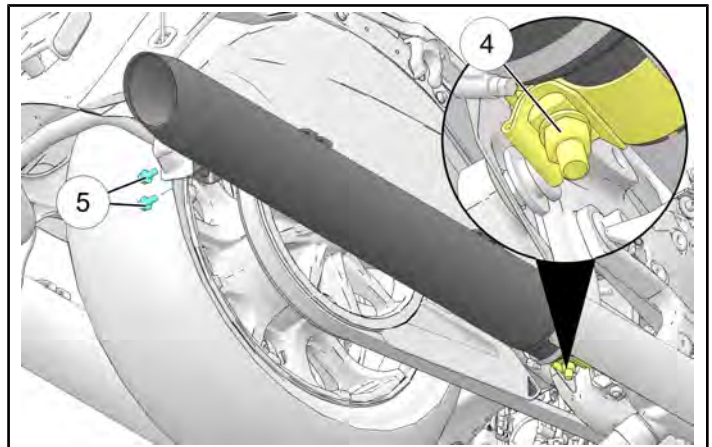

11. Remove antenna, if applicable.

12. Disconnect wheel speed sensor.

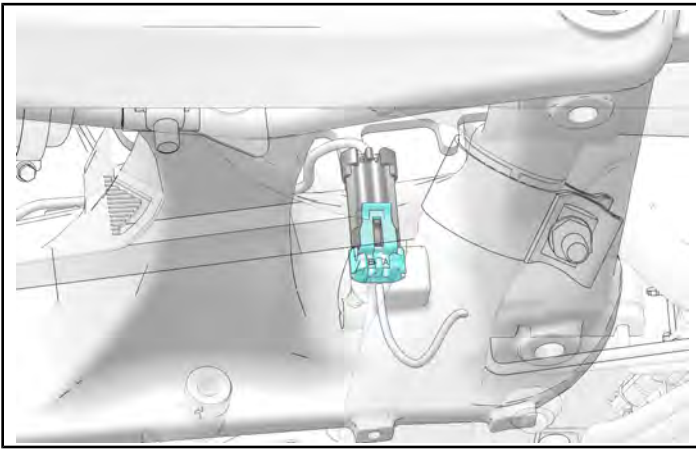

13. Cut two cable ties and remove wheel speed sensor and brake line p-clamps.

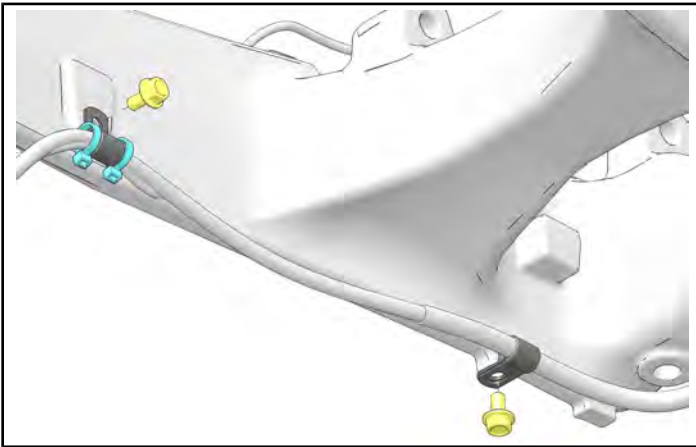

14. Remove two caliper mounting fasteners ⑥ and remove caliper.

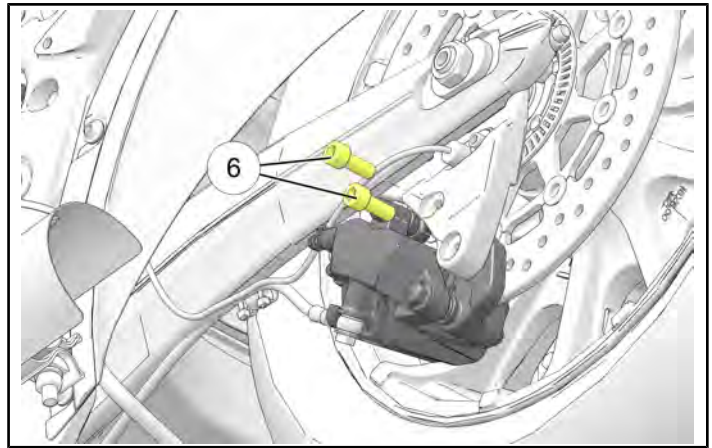

**CAUTION**

Do not hang rear brake caliper brake line or twist the brake line or damage may result.

**NOTICE**

Do not apply rear brake pedal after the brake caliper has been removed.

15. Remove rear ABS wheel speed sensor mounting fastener ⑦, sensor ⑧, and shims ⑨, if applicable.

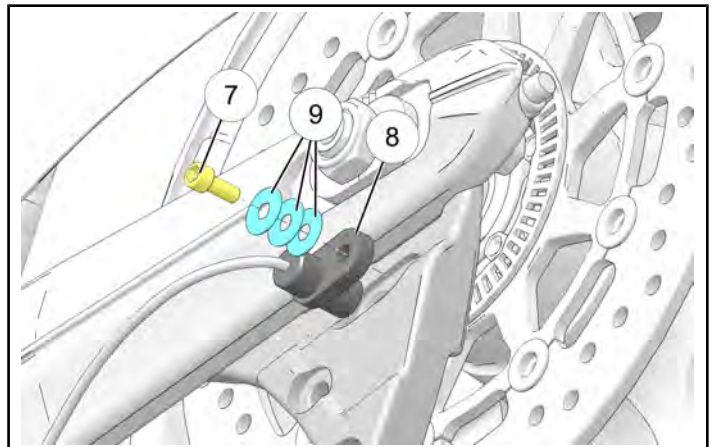

**NOTICE**

Move sensor aside so that it is not damaged.

**NOTICE**

Not all models will have shims.

16. Remove Axle Nut ⑩ and Washer ⑪ from left side of swingarm.

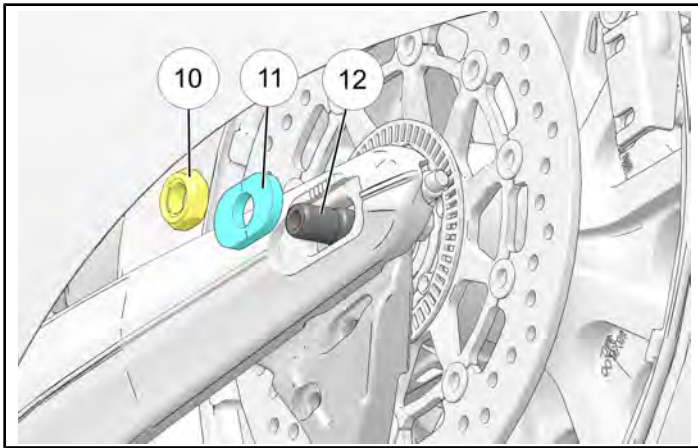

**IMPORTANT**

DO NOT loosen adjusters during removal.

17. Remove axle ⑫ from right side of swingarm.

18. Push wheel forward and slide drive belt to the right side off of the rear sprocket.

19. Lift motorcycle to allow the rear wheel enough clearance. Remove rear wheel assembly by sliding it to the rear of the motorcycle.

20. Located in front of the rear tire, disconnect EVAP lines and remove Canister (if equipped).

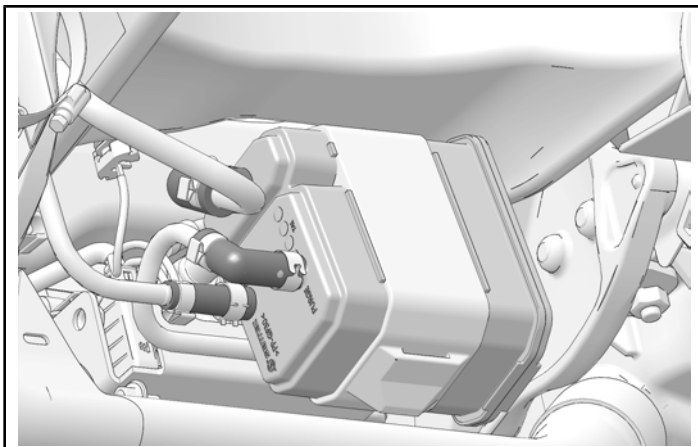

21. Remove the plastic darts ⑰ securing the rear wheel debris flap to the forward upper edge of the rear fender.

22. Remove the tip over sensor connector ⑱ fasteners located on the rear wheel debris flap and remove debris flap under the rear fender.

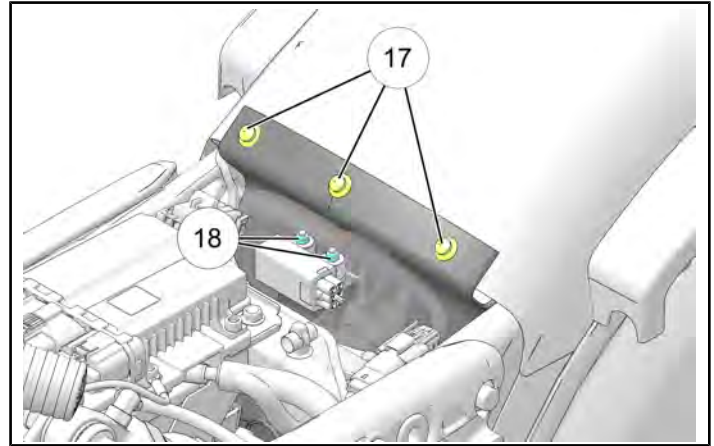

23. Remove swingarm nut ⑭ from the left side of the swingarm pivot shaft and discard.

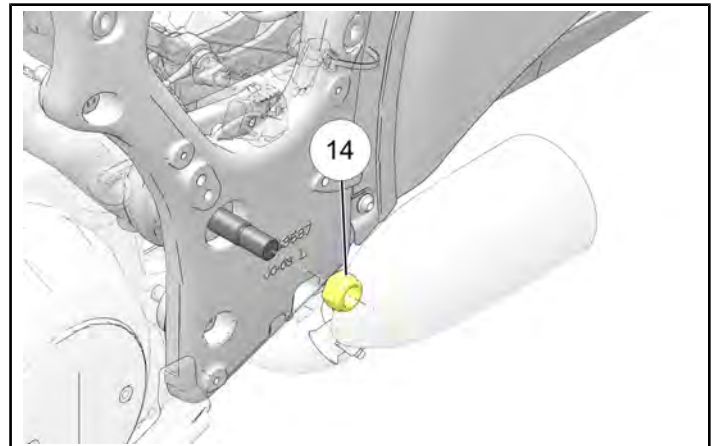

**STOP!**

Discard swingarm nut

24. Remove the pivot jam nut ⑮ located on the right side of the swingarm pivot shaft.

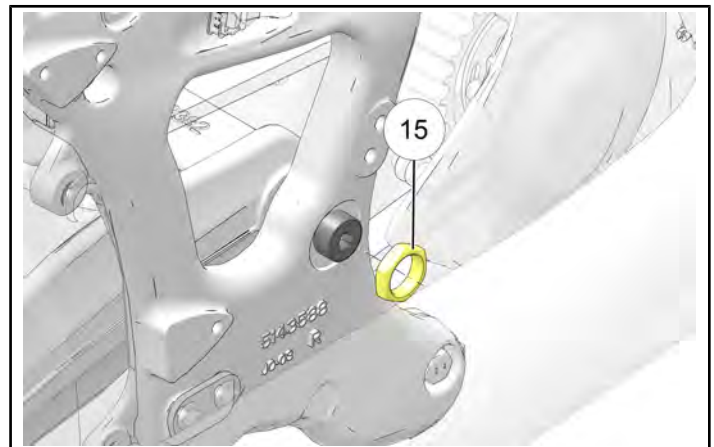

25. Use an 8 mm hex wrench to thread the swingarm shaft ⑯ out of the right-hand side of the frame.

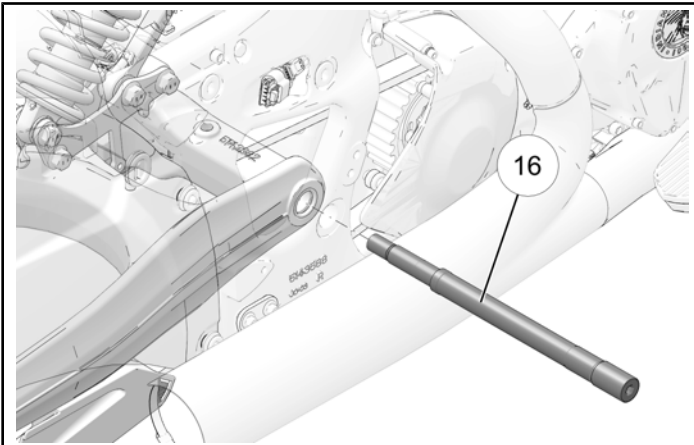

**NOTICE**

A soft faced rubber mallet may be used to help remove the pivot shaft.

**IMPORTANT**

Second technician must hold the swingarm while removing the pivot shaft.

**CAUTION**

Use caution not to damage the ABS module while lowering the swingarm.

26. Remove swingarm with shock and pushrod assembly.

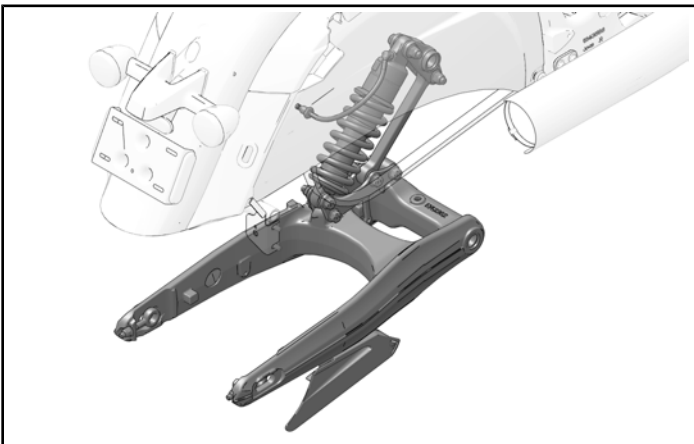

**CAUTION**

Route the air line down along the shock assembly before removing the swingarm assembly.

27. Remove bottom pushrod fastener and nut.

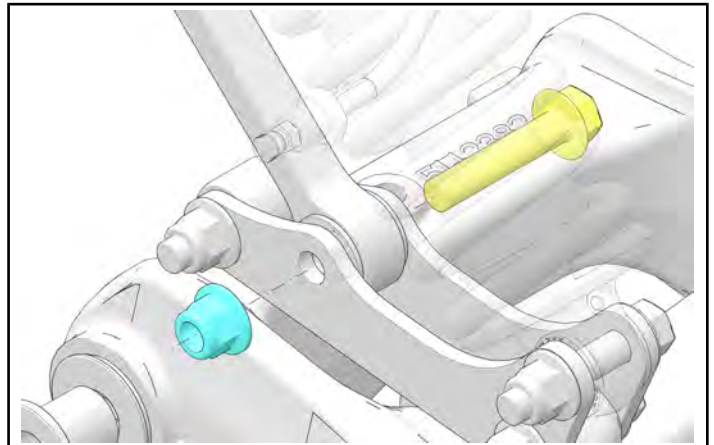

**STOP!**

Loop a cable tie through the lower pushrod hole. Using a paint pen, mark the pushrod with an X.

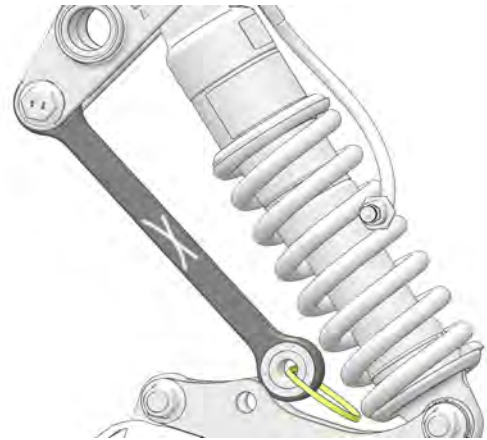

28. Remove fastener ① from the shock rocker.

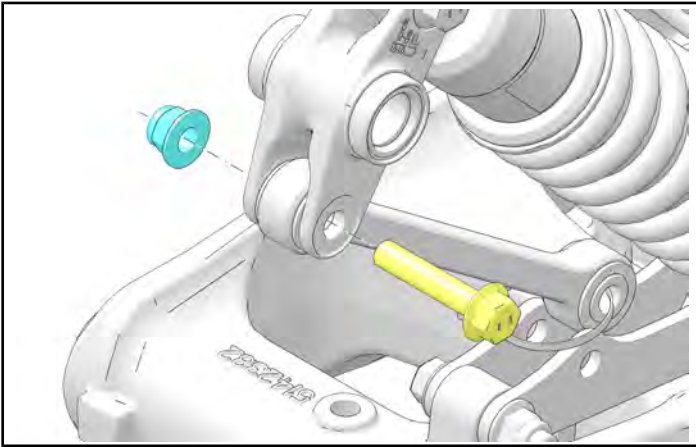

**IMPORTANT**

Note the orientation of the fasteners for installation

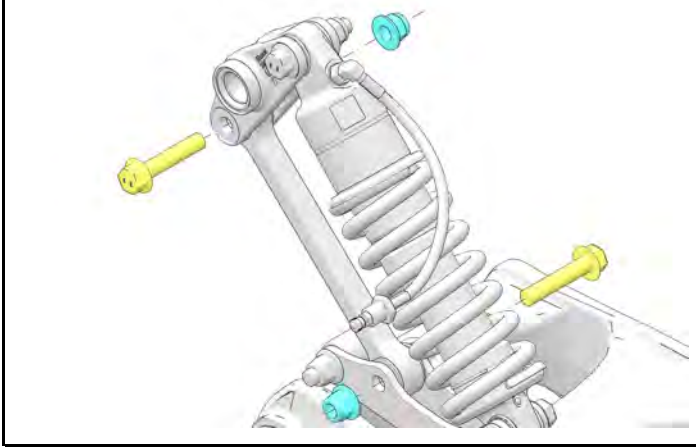

29. Discard the pushrod.



Verify the pushrod being disposed was marked with an X and has a cable tie looped through one end.

## I-24-07-BA: SHOCK PUSHROD INSTALLATION (CHIEFTAIN / ROADMASTER / SPRINGFIELD)

1. Install NEW pushrod into top shock rocker. Install shock fastener ①. Torque to specification.

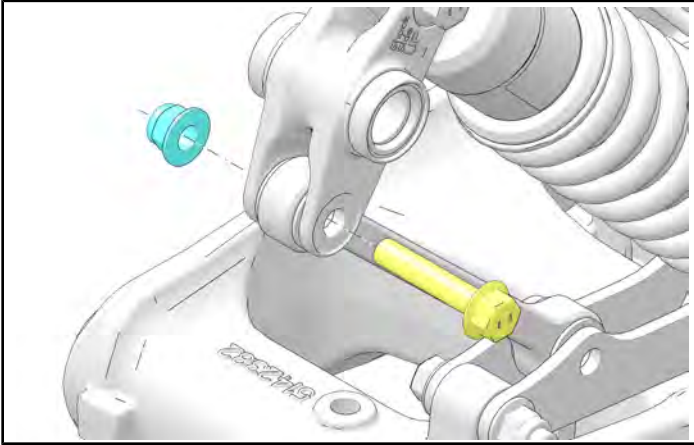

### IMPORTANT

Note the orientation of the fasteners during installation

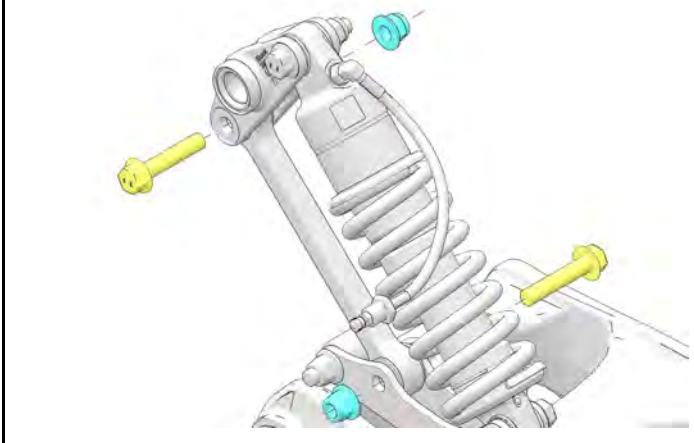

### TORQUE

Shock Fastener:  
**96 ft-lbs (130 N·m)**

2. Install bottom pushrod fastener and nut. Torque to specification.

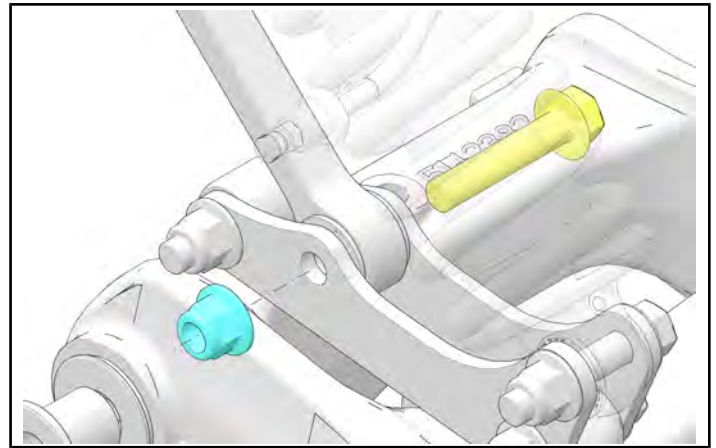

### TORQUE

Shock Fastener:  
**96 ft-lbs (130 N·m)**

3. Apply a thin film of grease to the left-hand swingarm spacer and press into position in the left-hand bearing bore.

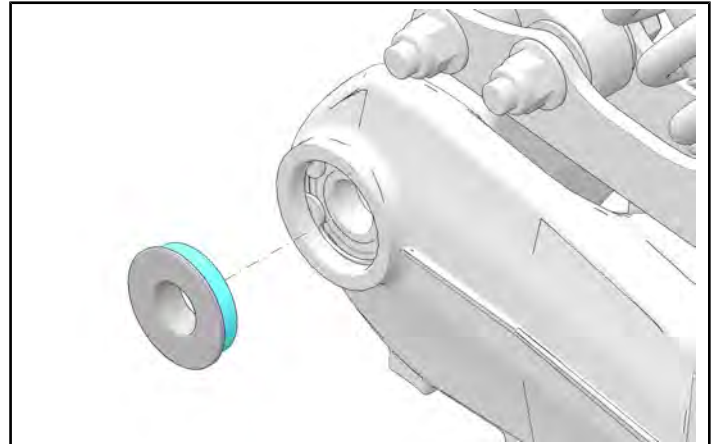

### NOTICE

Apply all-purpose grease to the left side spacer so it stays in position when swingarm is installed.

4. With the help of an assistant, install the swingarm assembly.

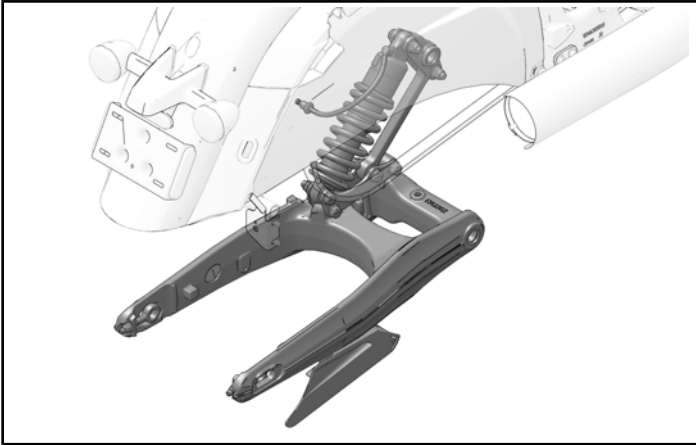

**IMPORTANT**

A second technician is important to guide the swingarm into position.

5. Install the swingarm pivot shaft through the right-hand side of the motorcycle. Use an 8 mm hex wrench to thread the pivot shaft 16 to the swingarm. Torque to specification.

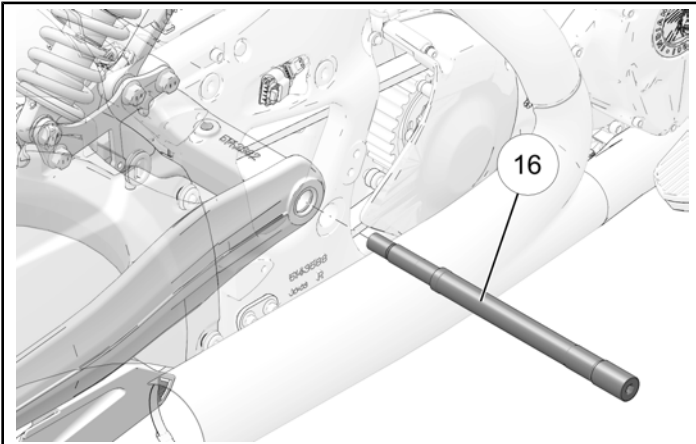

**TORQUE**

Swingarm Shaft:  
**8 ft-lbs (11 N·m)**

6. Install the swingarm shaft jam nut 15 onto the end of the swingarm pivot shaft the right-hand side of the motorcycle. Torque jam nut to specification.

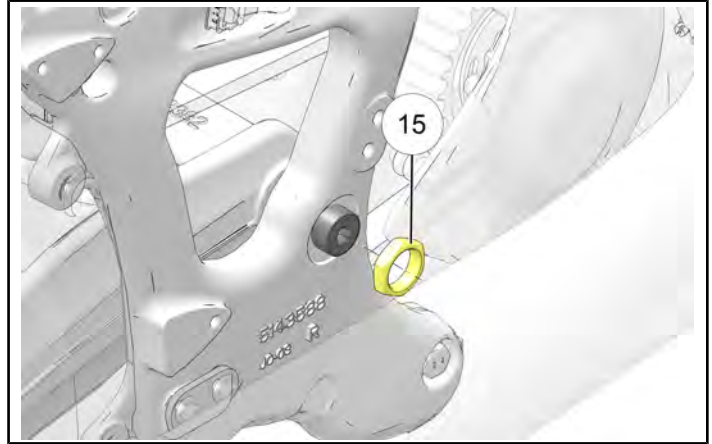

**TORQUE**

Swingarm Shaft Jam Nut:  
**75 ft-lbs (102 N·m)**

7. Install NEW swingarm nut ⑭ from the left-hand side of the swingarm pivot shaft.

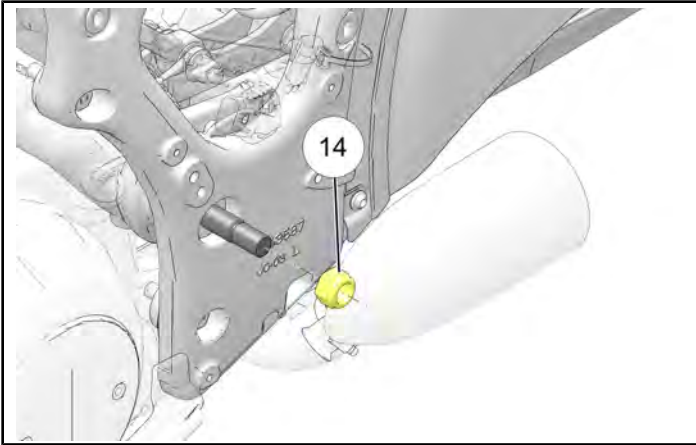

**STOP!**

Install a NEW swingarm nut ⑭. The swingarm nut cannot be reused once removed from the swingarm shaft.

**NOTICE**

Apply all-purpose grease to the shoulder of the face of the new nut prior to installation.

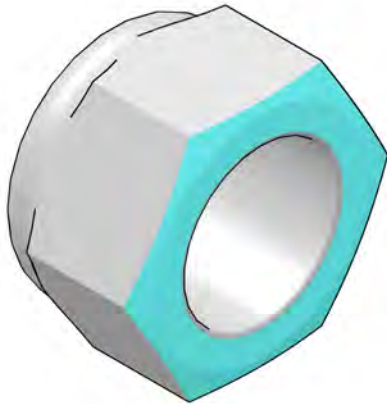

**TORQUE**

Swingarm Nut:  
65 ft-lbs (88 N·m)

8. Install shock air hose into position and install nut ③ securing the shock air hose to the frame. Torque nut to specification.

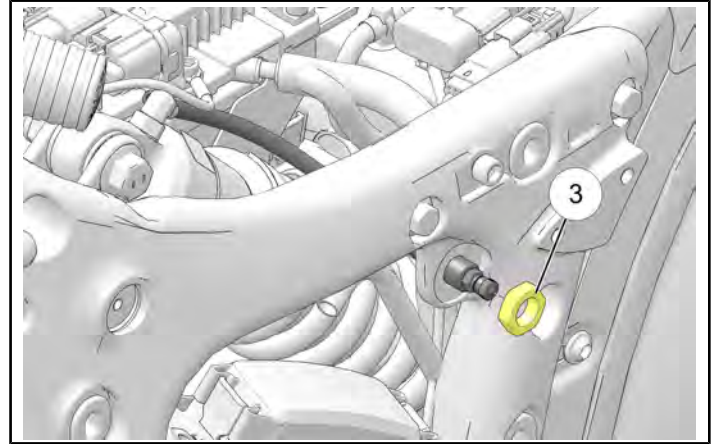

**TORQUE**

Shock Air Line Jam Nut:  
20 ft-lbs (27 N·m)

9. Install canister and connect EVAP lines (if equipped).

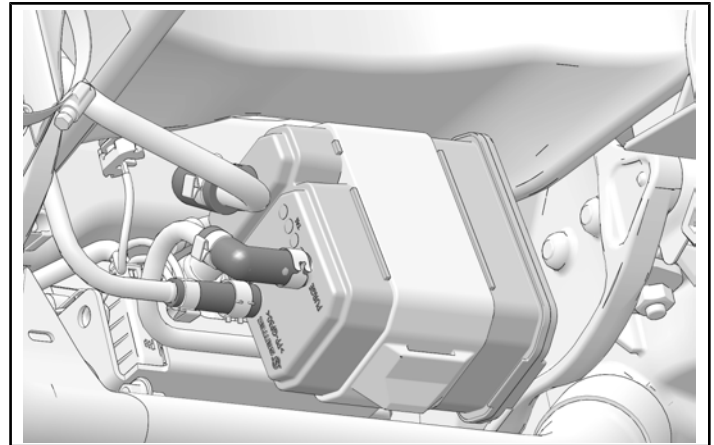

10. Install the debris flap and three plastic dart clips ⑰ and reconnect the tip over sensor ⑱.

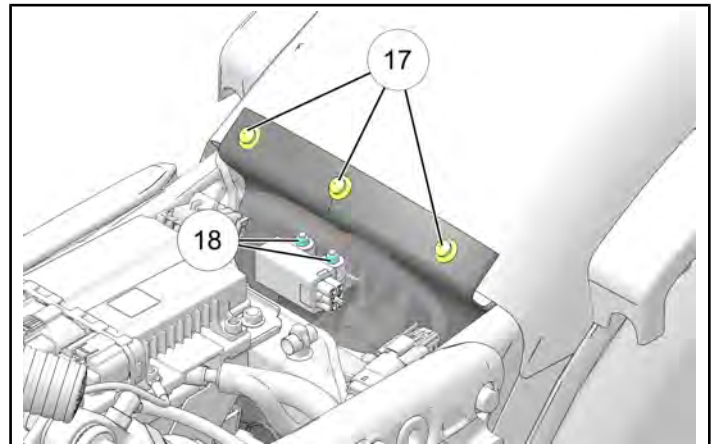

11. Connect the wheel speed sensor located at the front of the swingarm.

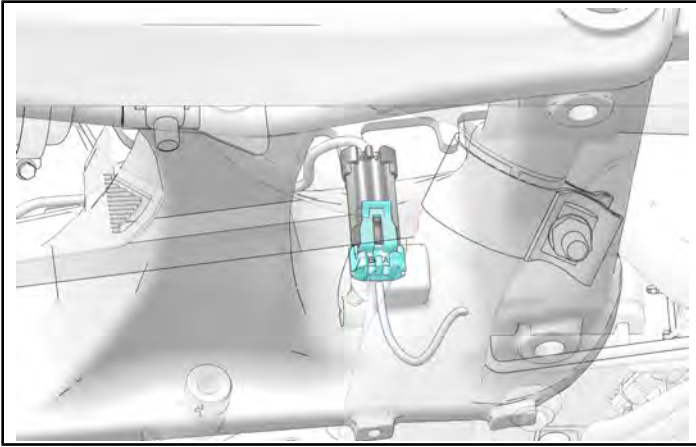

12. Verify the routing and retention points are correct.  
See **page 40**

13. Install rear wheel.

14. Push wheel forward and slide drive belt onto the rear sprocket.

15. Install axle ⑫ from right-hand side of the swingarm.

16. Install Washer ⑪ and Axle Nut ⑩ from left-hand side of the swingarm. Torque axle nut to specification.

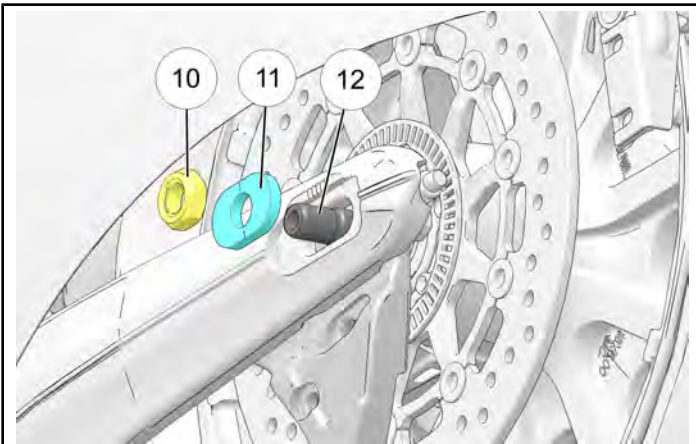

#### TORQUE

Axle Nut:

- 1. Torque to 15 ft-lbs (20 N·m) 2. Torque to 65 ft-lbs (88 N·m)**

#### STOP!

Wheel alignment and belt tension should be accurate if the procedure was performed correctly. Verify belt tension using **PV-43532** (reference the Service Manual) and wheel alignment.

17. Install rear ABS wheel speed sensor ⑧, shims ⑨ (if applicable), and sensor mounting fastener ⑦. Torque fastener to specification.

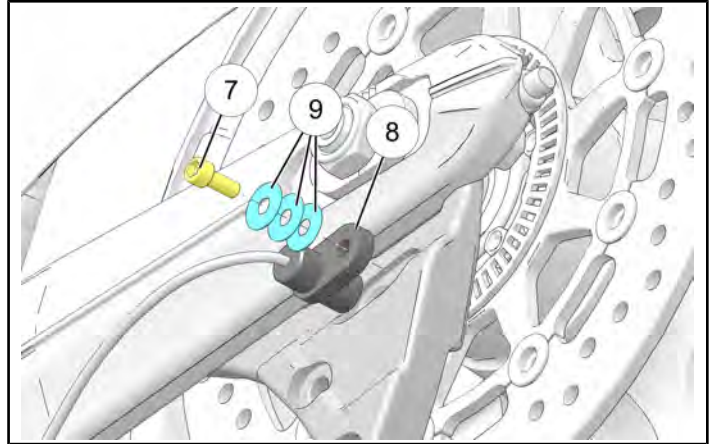

#### TORQUE

Wheel Speed Sensor Fastener:  
**96 in-lbs (11 N·m)**

18. Install rear caliper and secure with two caliper mounting fasteners ⑥.

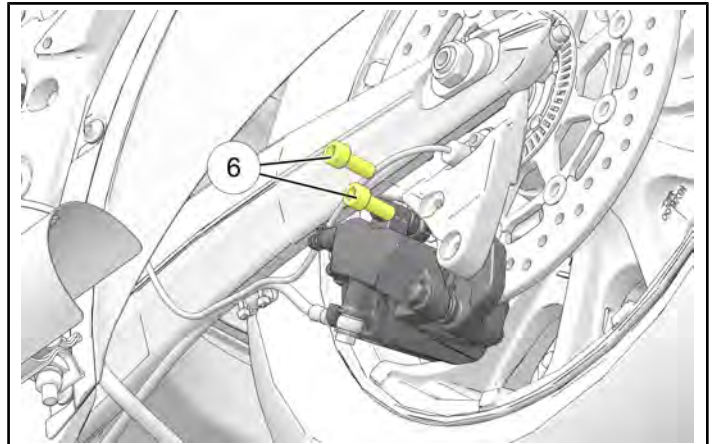

#### TORQUE

Rear Caliper Mounting Fasteners:  
**31 ft-lbs (42 N·m)**

19. Verify brake line and wheel speed sensor lines are routed correctly.

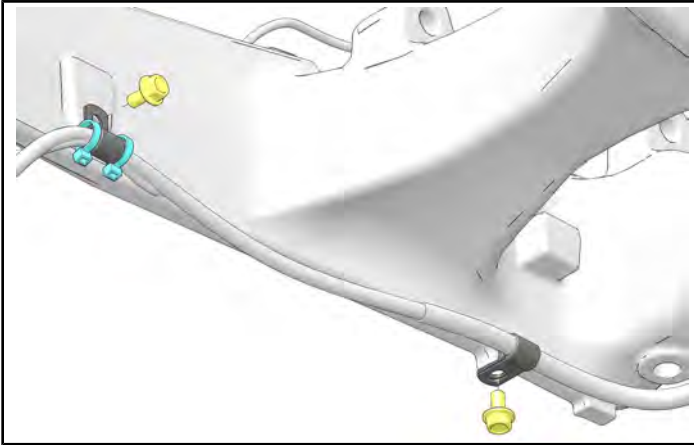

20. As shown above, install two cable ties securing the wheel speed sensor and brake line.

21. Install p-clamp fasteners. Torque to specification.

**TORQUE**

P-Clamp Fasteners:  
**88 in-lbs (10 N·m)**

22. Install shock pin through the rear shock linkage and frame and secure with snap ring ⑬.

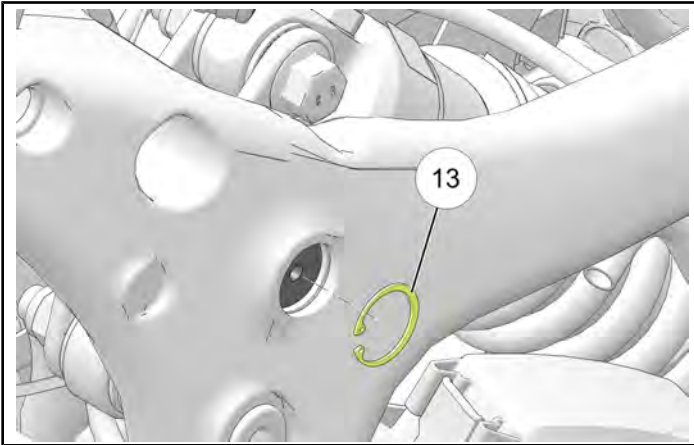

**NOTICE**

Lift/lower rear of the motorcycle to line up shock pin.

**IMPORTANT**

Verify the snap ring is not bent or damaged and is fully seated in the groove. Submit an ASK Polaris case if a new snap ring is required.

23. Remove the M6 x 1.0 fastener from the shock pin.

24. Remove scissor lift.

25. Install antenna if removed.

26. Install left and right-hand muffler and secure with mounting fasteners ⑤. Torque to specification. Torque clamp ④ to specification.

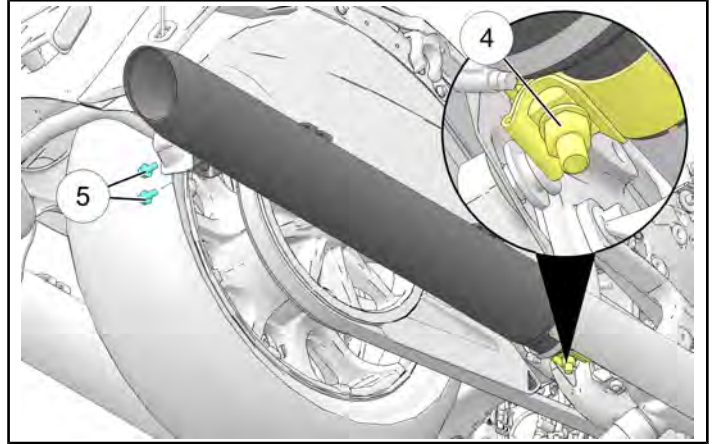

**TORQUE**

Muffler Mounting Fasteners:  
**18 ft-lbs (24 N·m)**

**TORQUE**

Muffler Clamp:  
**40 ft-lbs (54 N·m)**

27. Remove electrical tape from the negative (-) and positive (+) terminals.

28. Connect positive (+) cable to the battery and torque to specification.

29. Connect negative (-) cable to battery and torque to specification.

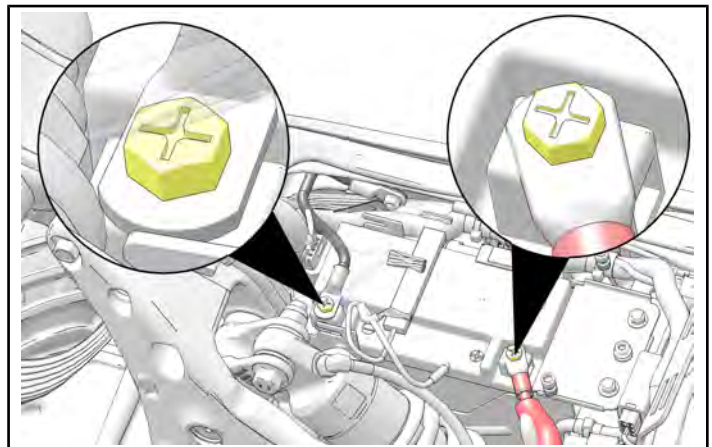

30. Apply dielectric grease over terminal areas for corrosion protection.

31. Install the VCM mounting plate to the battery box.  
Slide the VCM tray toward the rear of the motorcycle to engage with battery box tabs. Install and torque the fastener ① to specification.

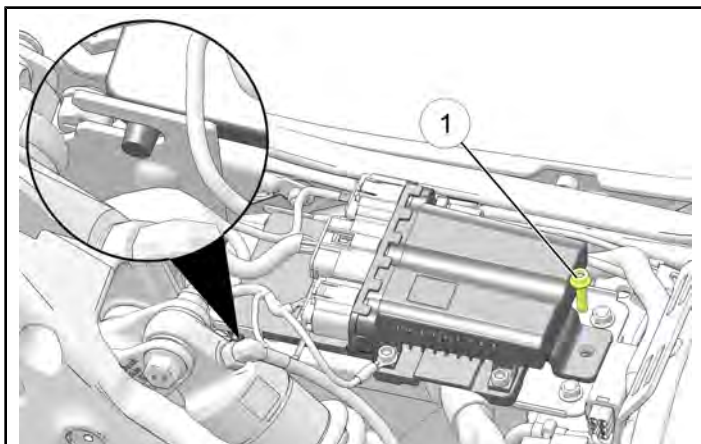

**⚠ CAUTION**

Do not allow VCM to contact the positive battery terminal.

**TORQUE**

VCM Mounting Plate Fastener:  
**88 in-lbs (10 N·m)**

## FINAL ASSEMBLY

### LOWER SIDE COVER INSTALLATION

1. Working from the right side of the motorcycle, push the corners of the cover to engage each tab with rubber grommets ① in frame.

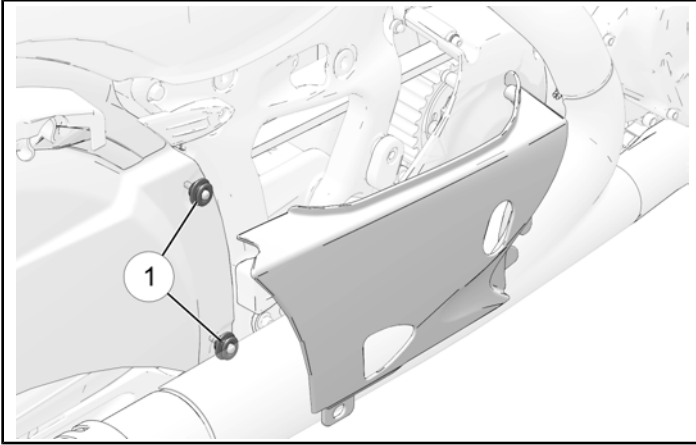

2. Working from the left-hand side of the motorcycle, install lower panel into position and install the three fasteners ② securing the panel to the frame. Torque fasteners to specification.

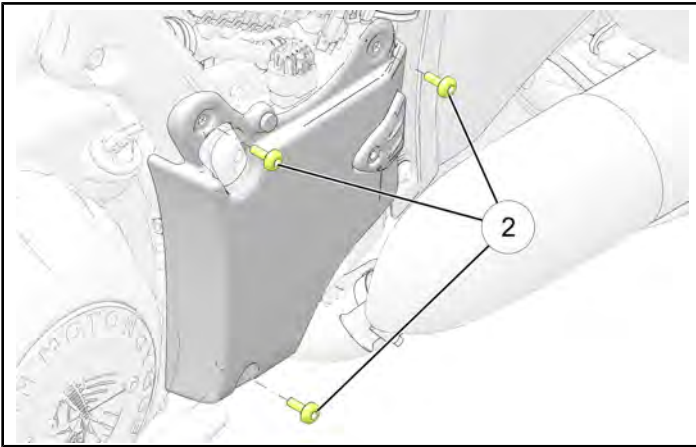

#### TORQUE

Left-Hand Side Cover Fasteners:  
**88 in-lbs (10 N·m)**

### SEAT INSTALLATION

1. With the rear of the seat elevated, push the front of the seat forward to engage the front retaining arms to the bracket behind the fuel tank.
2. Install a washer along with the passenger seat fastener ② as shown. Torque to specification.

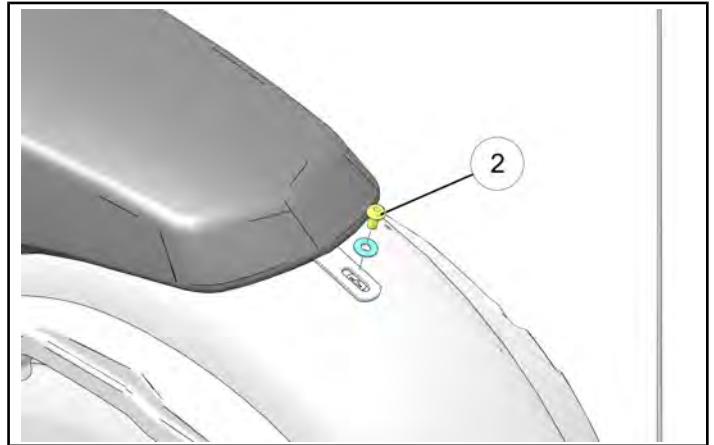

3. Install the two fasteners ① securing the driver's seat to the frame. Torque to specification.

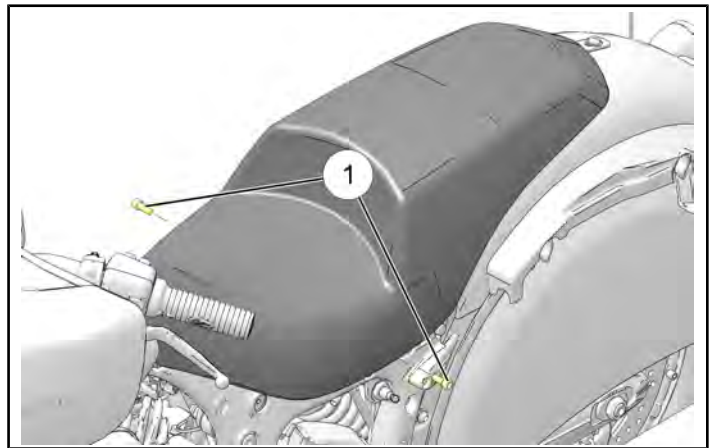

#### TORQUE

Seat Fasteners (All):  
**18 ft-lbs (24 N·m)**

#### NOTICE

It may be necessary to lift the seat skirt to access the side fasteners on some models.

## TRUNK INSTALLATION (IF EQUIPPED)

1. Lift the flap at the rear of the passenger seat pad to access the vehicle side of the trunk harness connector and lay harness on fender.



2. Slide the trunk forward ① onto the mounting bracket and lower ② the rear of the trunk until fully seated.

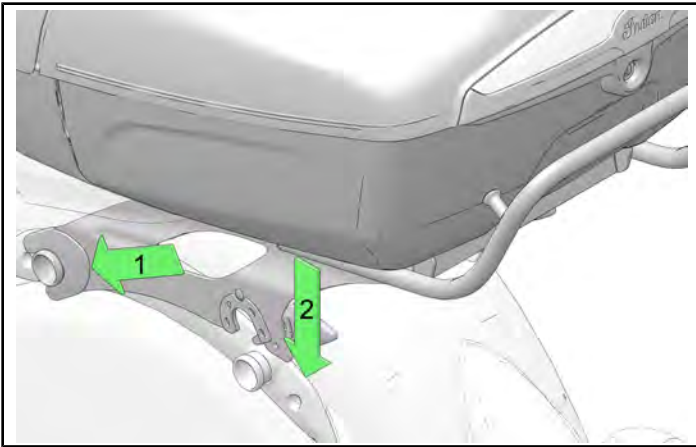

3. Push the trunk locking levers ③ down until fully seated and the trunk is held securely in place.

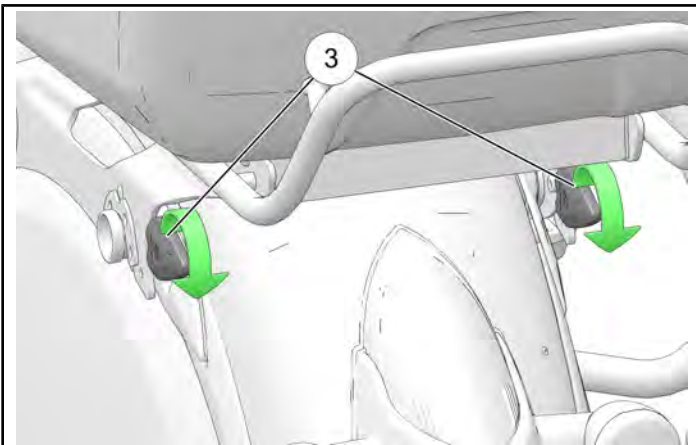

4. Reconnect the trunk harness connector ④.

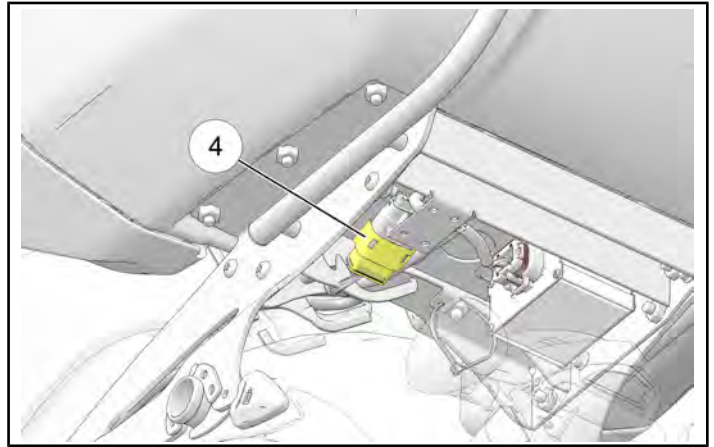

5. If applicable, install the mounting fasteners ⑤ into left and right locking levers.

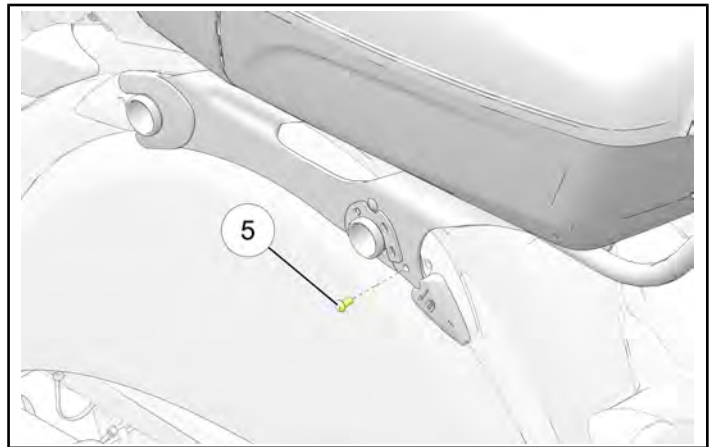

## SADDLEBAG INSTALLATION

1. Place the hard bag in a fully seated position on the muffler.
2. Remove the saddlebag fastener bolts ②.

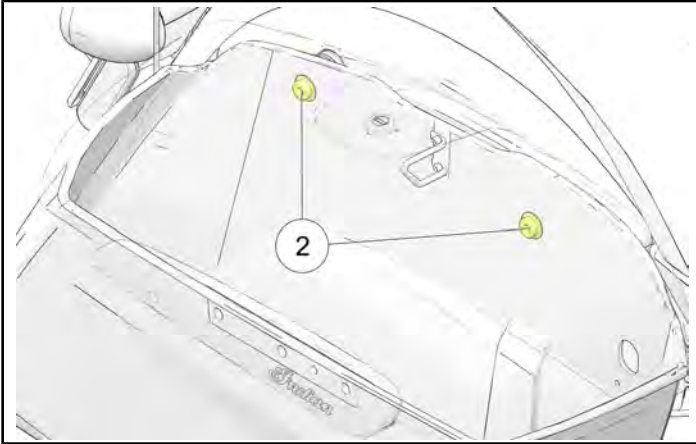

### TORQUE

Saddlebag Fasteners:  
**18 ft-lbs (24 N·m)**

3. Connect the saddlebag lock wiring near the seat ①.

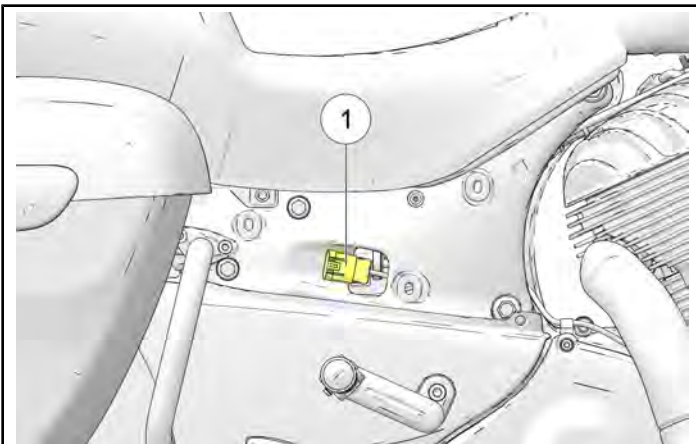

## UPPER SIDE COVER INSTALLATION

1. Push the corners of the upper cover evenly straight to engage each tab to the rubber grommet in frame

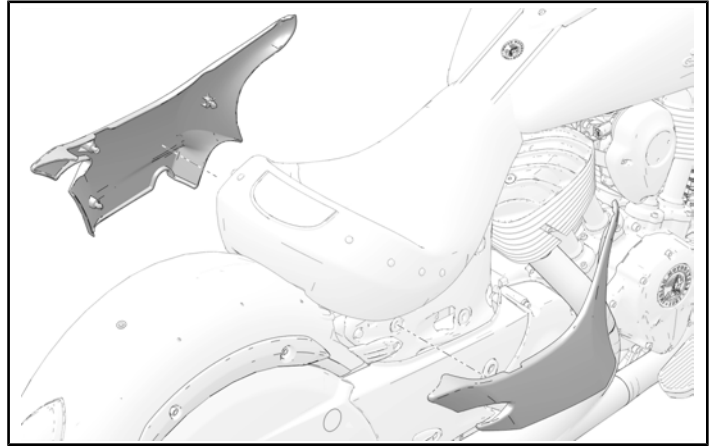

2. Press and release the rear brakes until firm.
3. Power on motorcycle and check for MIL lights.

## SUBMITTING A CLAIM

1. Submit a Service Bulletin Warranty Claim for I-24-07-BA.

## **SUPPLEMENTAL INFORMATION**

### **PARTS RETURN / DESTRUCTION / DISPOSAL INFORMATION**

Dispose of parts according to local regulations. Under no circumstances shall the parts removed be re-used, sold, or re-purposed for another application. It is your dealership / distributor's responsibility to make sure every part replaced (related to the communication) is taken out of circulation and disposed of properly.

### **CUSTOMER NOTIFICATION**

Dealers are required to review their sales records and make arrangements with customers for Recall completion. In addition to consumer units, dealers are required to correct any affected units in their inventory. Polaris will be mailing a notification letter to consumers affected by this Recall. Polaris will also send an email to owners for whom Polaris has a valid email address.

#### *NOTICE*

International consumer notifications in distributor countries: International distributors are responsible for all consumer notifications. Polaris does not contact consumers of distributors.

### **REFERENCE INFO**

#### **ADDITIONAL REFERENCE INFORMATION**

For additional reference information not included in the document, click [HERE](#)

### **FAQS**

Frequently Asked Questions (FAQs) related to this recall can be found at the end of this document.

# CHALLENGER / PURSUIT ROUTING RETENTION

## ADJUSTER MODELS

### Shock Adjuster Routing

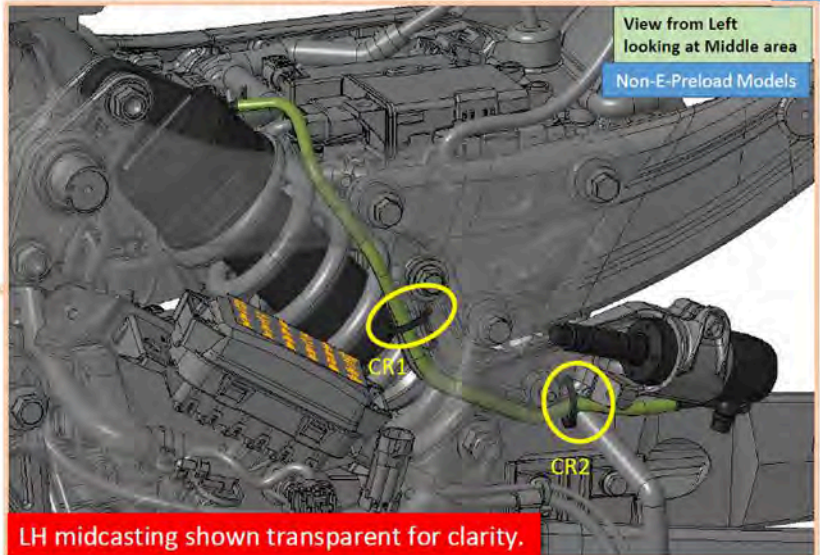
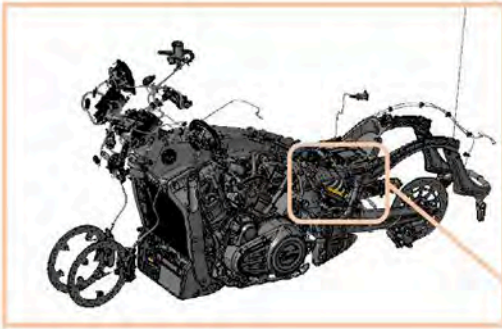

#### Critical Notes:

- CR1,CR2 - Shock adjuster hose is secured to shock adjuster bracket by cable ties in 2 locations shown.
- Cable ties must be tightly secured.

ENG-FORM-01004 Rev07

## E-PRELOAD MODELS

### Shock Electronic Adjuster Routing

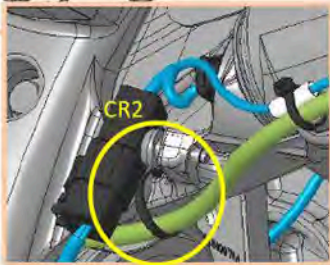
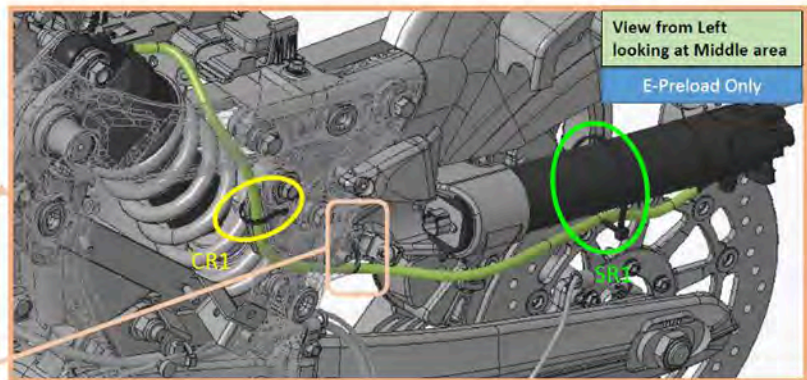
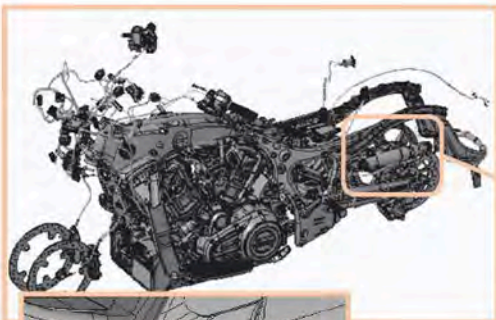

#### Note:

- SR1 - Center cable ties must go around E-Preload assembly.

#### Critical Notes:

- CR1,CR2 - Shock adjuster hose is secured to shock adjuster bracket by cable ties in 2 locations shown.
- Cable ties must be tightly secured.
- CR2 - Only shock adjuster hose is retained by zip tie, the electrical harness is not.



ENG-FORM-01004 Rev07  
PRINTED REPRODUCTION OF THIS PAGE IS UNCONTROLLED

# CHIEFTAIN / ROADMASTER / SPRINGFIELD ROUTING RETENTION

## CLASSIC MODELS

### ABS mounting with Electrical Routing

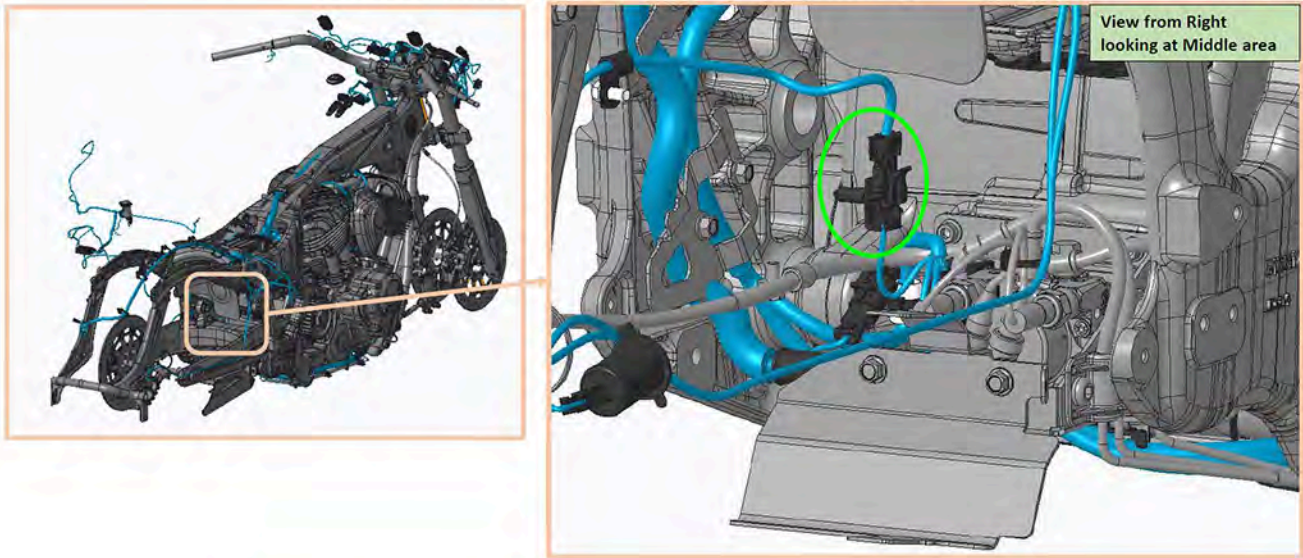

**Note:**

- Harness is connected at 1 location to ABS Module as shown.

### ABS mounting with Frame Bracket

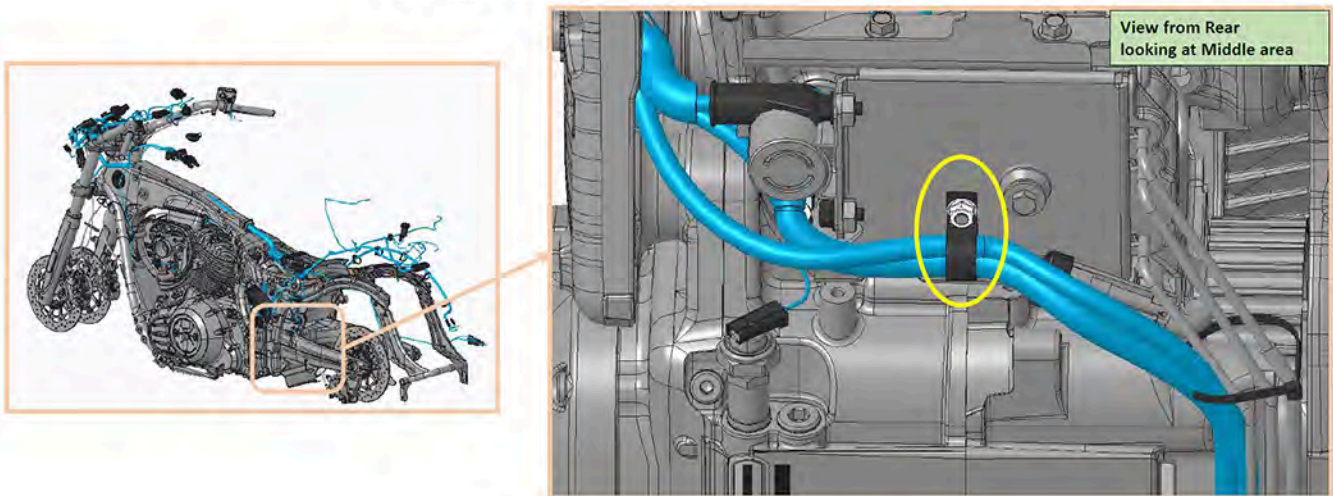

 **Critical Note:**

- Harness is secured at 1 location.

## Rear ABS Brake Line sensor connection

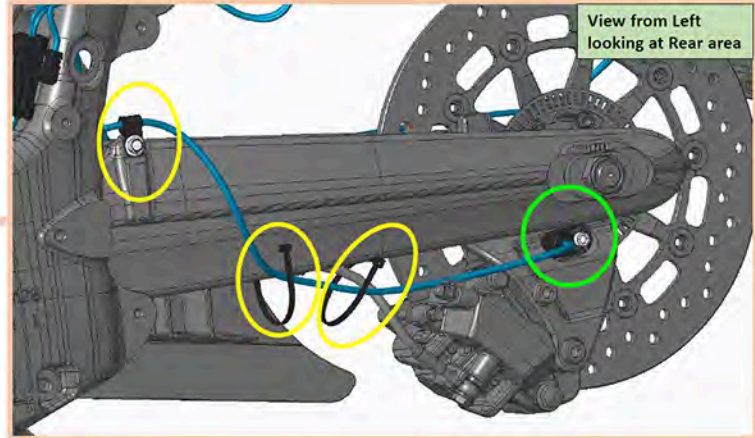
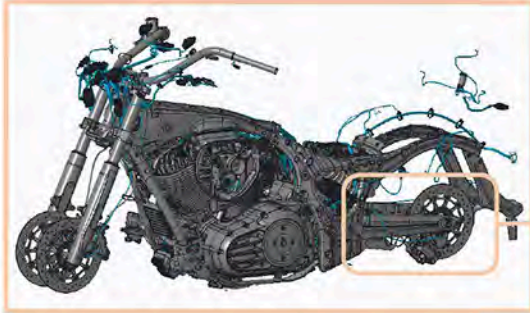

### Critical Notes:

- Harness is secured at 3 locations.
- Ensure cable-ties are fully tightened.

### Note:

- Harness is connected at 1 location as shown.

## Electrical Routing with Battery

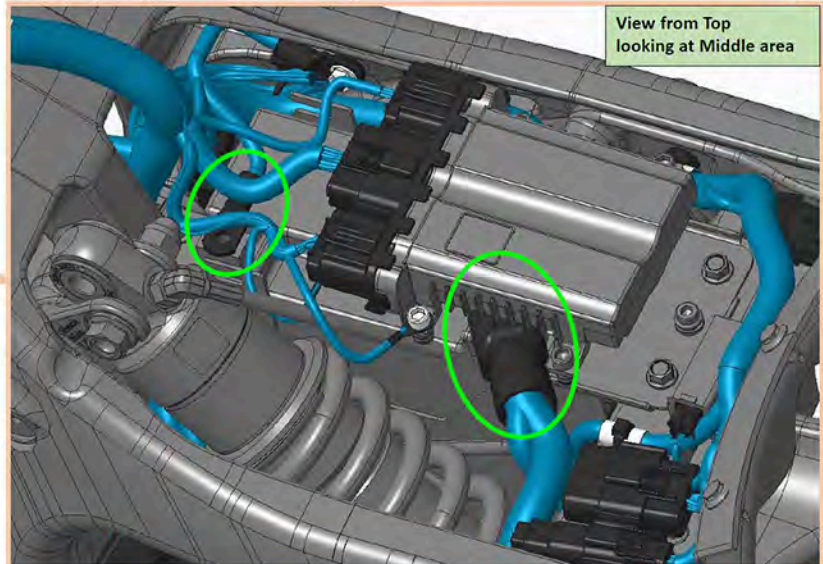
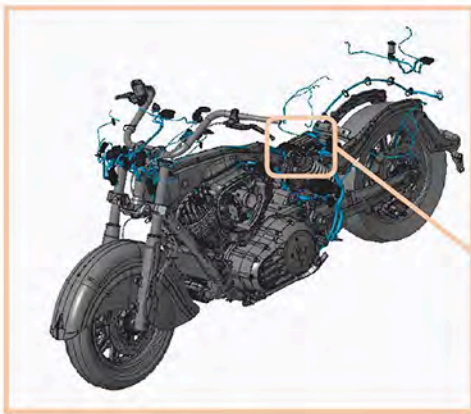

### Note:

- Harness is secured to battery in 2 locations as shown.

## Rear ABS Brake Line Routing – Rear Caliper

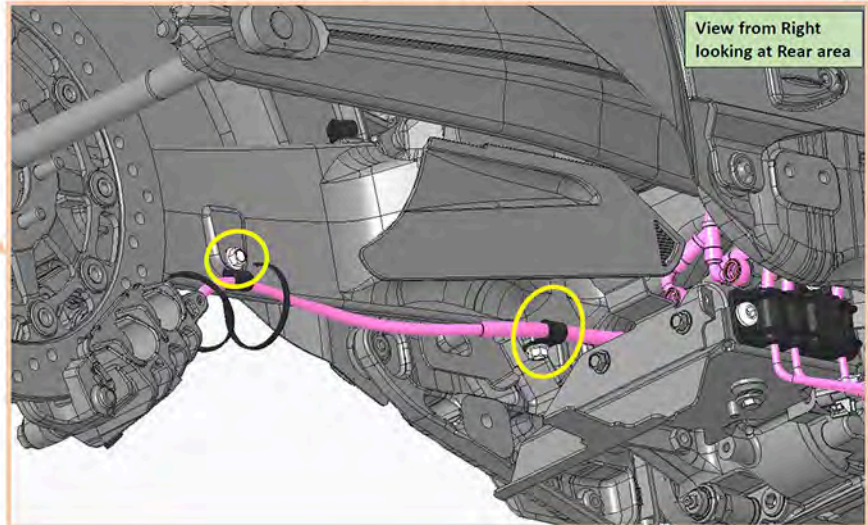
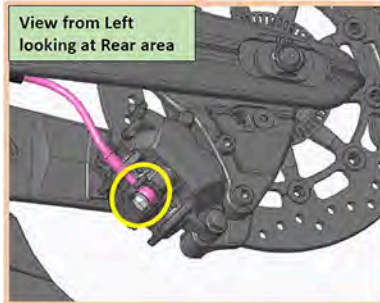
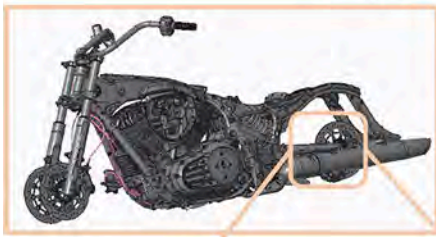

### Critical Notes:

- ABS Brake line is secured at 3 locations as shown.
- Do not allow caliper to hang from ABS brake line assembly unsupported.

### Rear ABS Brake Line Routing – Rear Caliper

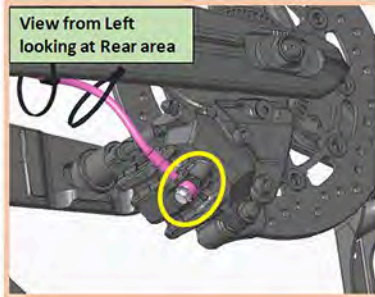

View from Left looking at Rear area

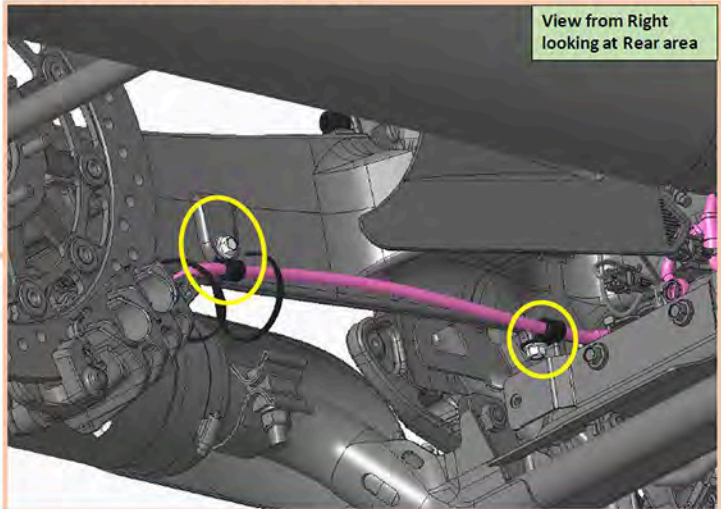

View from Right looking at Rear area



**Critical Notes:**

- ABS Brake line is secured at 3 locations as shown.
- Do not allow caliper to hang from ABS brake line assembly unsupported

### Rear ABS Brake Line sensor connection

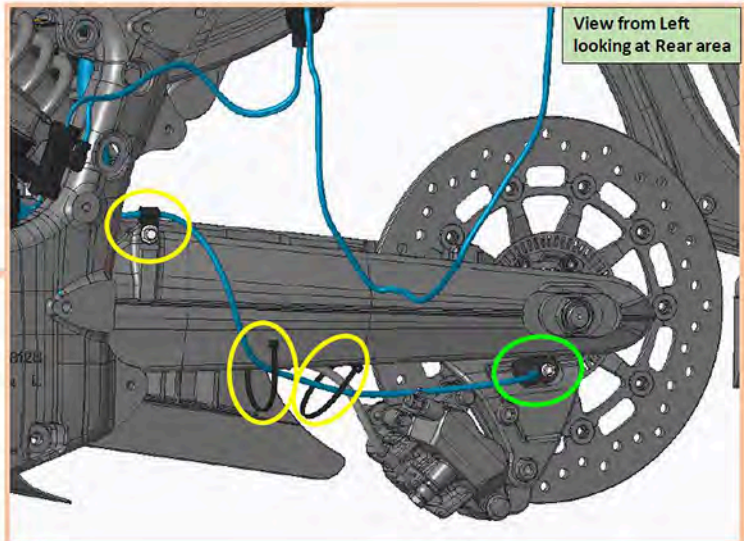
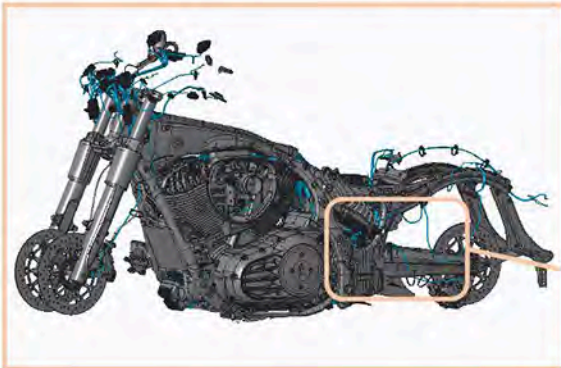

View from Left looking at Rear area



**Critical Notes:**

- Harness is secured at 3 locations.
- Ensure cable-ties are fully tightened.

**Note:**

- Harness is connected at 1 location as shown.

## ABS mounting with Frame Bracket

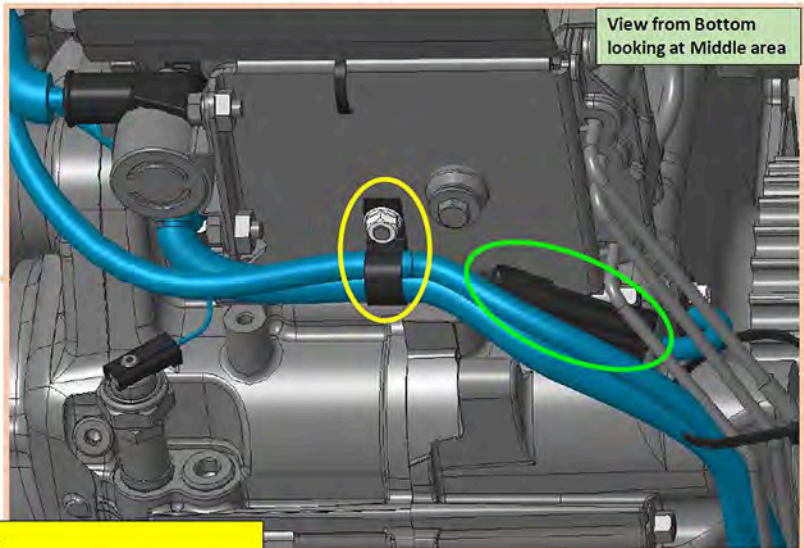
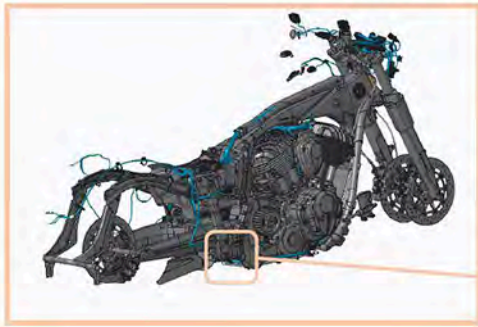

View from Bottom  
looking at Middle area



### Critical Note:

- Harness is secured at 1 location.

### Note:

- Harness is connected at 1 location as shown.

## ABS mounting with Electrical Routing

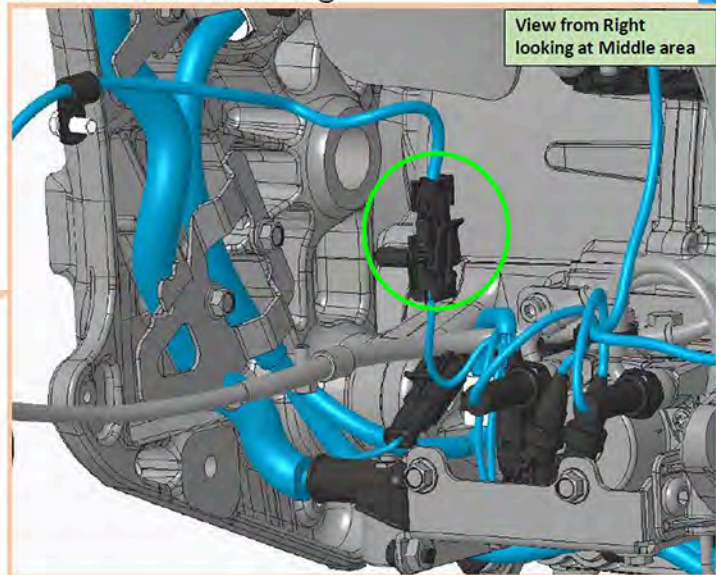
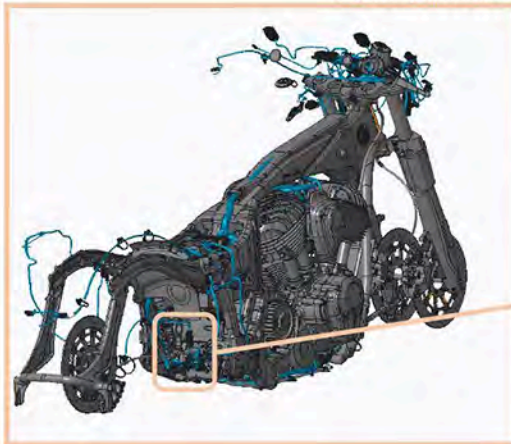

View from Right  
looking at Middle area

### Note:

- Harness is connected at 1 location to ABS Module as shown.

## Electrical Routing with Battery

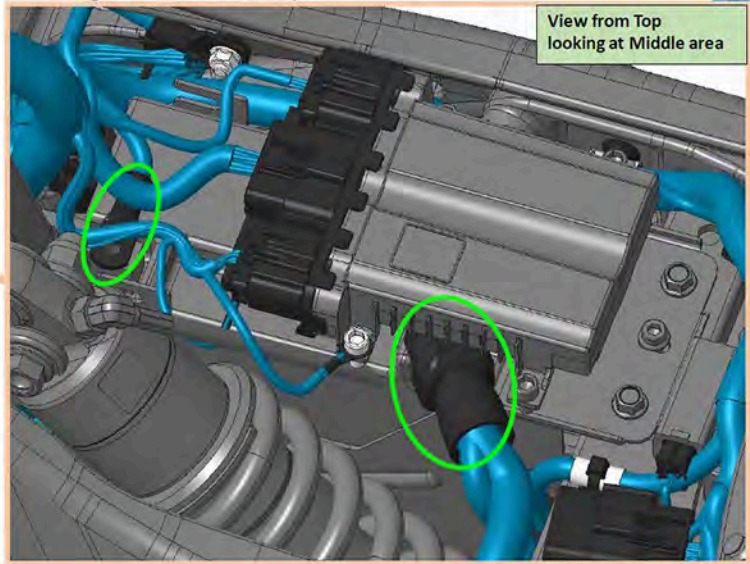
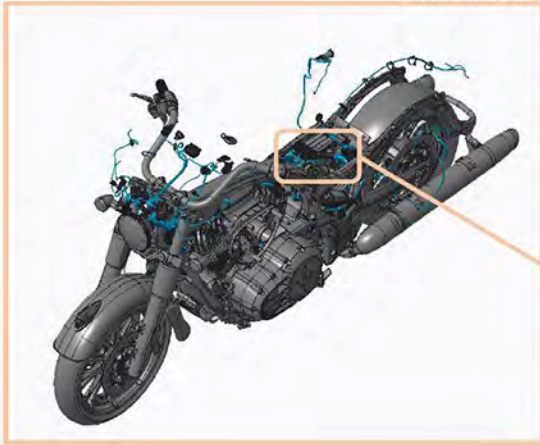

### Note:

- Harness is secured to battery in 2 locations as shown.

## Fuel Load Line Mount with LH Mid-Cast

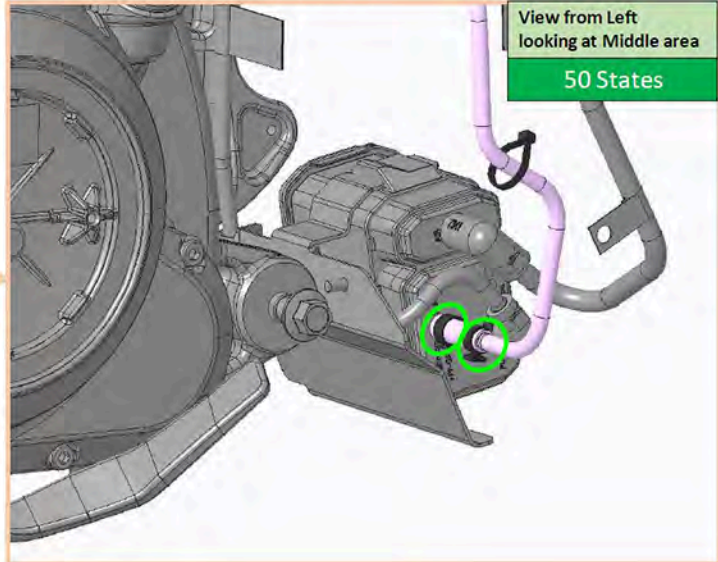
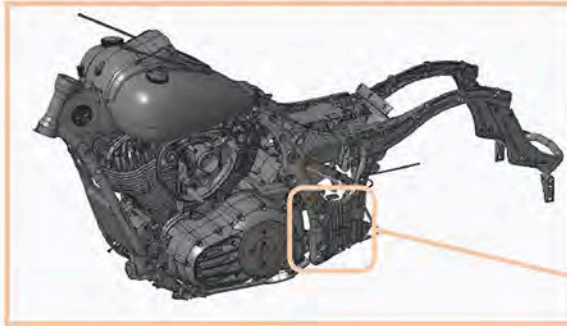

### Note:

- Fuel load line is connected at 2 locations as shown.

## Fuel Vent Mount with Canister

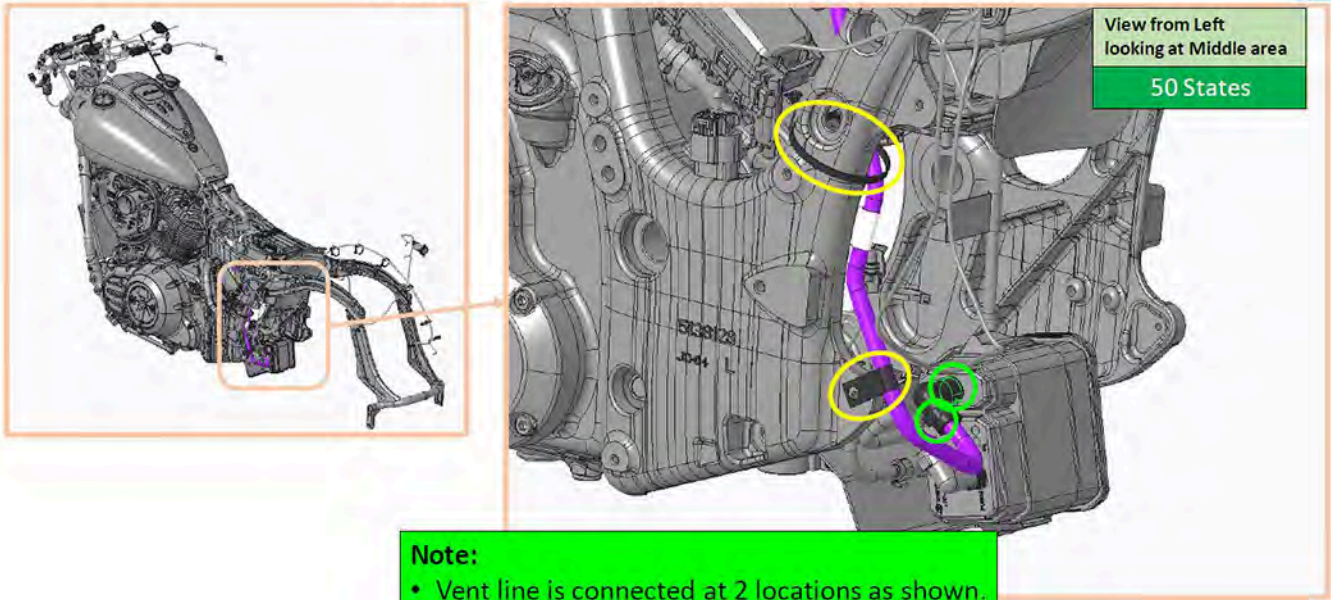

### Note:

- Vent line is connected at 2 locations as shown.



### Critical Note:

- Vent line is secured at 2 locations with Frame brackets as shown.

## Fuel Vent Mount with Canister

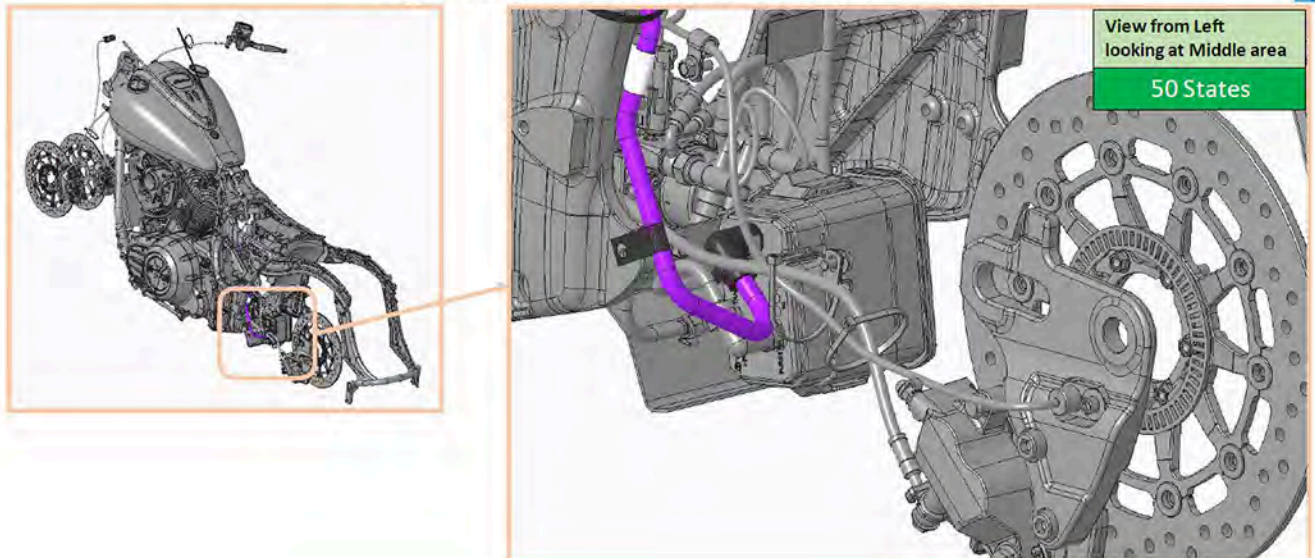

### Note:

- Vent line is routed under brake line as shown



Indian Motorcycle  
Company  
P.O. Box 47700  
Medina, MN 55340-9960

**IMPORTANT SAFETY RECALL**  
This notice applies to your vehicle  
Recall Campaign: **24V-550**

Subject: **2024 Challenger / Pursuit / Chieftain / Springfield /  
Roadmaster  
Shock Pushrod Replacement**  
PLEASE READ IMMEDIATELY

VIN: I-24-07  
First Name Last Name  
Address  
City, State ZIP

Dear Indian Motorcycle Owner,

This notice is sent to you in accordance with the National Traffic and Motor Vehicle Safety Act. Indian Motorcycle has decided that a defect which relates to motor vehicle safety exists in 2024 Challenger / Pursuit / Chieftain / Springfield / Roadmaster motorcycles. Our records show you have purchased an affected vehicle.

**The reason for this notice:**

Indian Motorcycle has determined that some Model Year 2024 Chieftain, Roadmaster, Springfield, Challenger, and Pursuit motorcycles may have been produced with a rear suspension pushrod, which does not meet design specifications. The rear suspension pushrod may buckle under load, which can result in pinching the main chassis harness, damage to the coolant reservoir, damage to the rear tire, or the rear of the motorcycle bottoming out under load, increasing the risk of a crash and serious injury.

**What you should do:**

Contact your authorized Indian Motorcycle dealer to schedule an appointment to have the repairs performed. Do not attempt repairs yourself. Repairs must be done only by an authorized Indian Motorcycle dealer. This repair should take approximately 2 hours. When making contact with your dealer, discuss parts availability, their schedule and how long they will need to keep your vehicle.

**What your dealership will do:**

To address this concern, Indian Motorcycle has authorized your dealer to install a new shock pushrod. This work will be performed by your dealer at no cost to you.

This notice was mailed to you according to our most current registration information. If you no longer own this vehicle, or if some of the contact information in this notice is incorrect, please contact your dealer to complete a transfer of ownership. Federal law requires that any vehicle lessor receiving this notice must forward a copy of this notice to the lessee within 10 working days after the day on which the notice is received.

If you need assistance contacting or locating an Indian Motorcycle dealer, or if you have questions your Indian Motorcycle dealer is not able to address, contact our Indian Motorcycle Owner Connections Department at 1-877-204-3697, scan the QR code, or go to <https://www.polaris.com/en-us/help-center/>.



If you previously paid for repair(s) to your vehicle for this specific condition prior to receiving this letter, you may be eligible to receive reimbursement for the cost of obtaining a pre-notification remedy of the problem associated with this recall. For more information regarding obtaining reimbursement please contact your Indian Motorcycle Dealer or Indian Motorcycle Owner Connections Department using the contact information above.

If you believe that Indian Motorcycle has failed to remedy this defect without charge or is unable to do so within a reasonable time, you may submit a complaint to the Administrator, National Highway Traffic Safety Administration, 1200 New Jersey Avenue SE., Washington, D.C. 20590; or call the toll-free Vehicle Safety Hotline at 1-888-327-4236 (TTY: 1-800-424-9153); or on the web go to [www.safercar.gov](http://www.safercar.gov).

We apologize for this inconvenience and assure you that we are committed to customer satisfaction and providing world-class products for riders to enjoy.

Sincerely,

**Indian Motorcycle Company**

For the latest updates to this safety recall, or to check if your vehicle is part of another safety recall, scan the QR code, or go to [www.polaris.com/en-us/on-road-recalls/](http://www.polaris.com/en-us/on-road-recalls/).





# Indian Motorcycle I-24-07 Safety Recall Heavyweight Shock Pushrod

---

Version: R01 (August 02, 2024)

## **Will Dealers have all the appropriate tools to complete this Safety Recall?**

Dealers will need to source a **M6- 1.0 bolt, minimum 13mm length**, to assist with removal & reinstallation of the rear shock linkage pin. Essential tool **PV-43532 Belt Tension Meter** is also required for Chieftain/Roadmaster/Springfield.

All other required tools are standard motorcycle shop service tools.

## **What if parts are showing on backorder or not available?**

Dealers should still place orders for the quantities required. It's important to get all orders entered into the system so Polaris can track demand and keep parts shipping to dealers.

## **What should dealers do with service parts in dealer inventory?**

No action is required for service parts. Dealer service parts are not affected by I-24-07.

## **Can I allow demos on vehicles that haven't had I-24-07 performed?**

While this is not a STOP RIDE, it is **STRONGLY** recommended that dealers complete the repair prior to operating an affected vehicle.