

SAFETY RECALL

NORTH AMERICA

Plug-in Hybrid Electric Vehicle Fires



Reference: 73B / NHTSA 24V-536

FCA US LLC



Remedy available for

2017 - 2018 (RU) Chrysler Pacifica
Plug-In Hybrid Electric Vehicles (PHEV)

Template Version 1.0

Revision	Edition	Detail
0	December 2024	Initial Version.

Vehicles previously notified of the Z11 recall (NHTSA 22V-077) will need to bring their vehicle in for recall completion, regardless of having the Z11 repair performed.

SYMPTOM DESCRIPTION

About 15,910 of the above vehicles may still be at risk of experiencing a fire originating from the high voltage (HV) battery even after having the remedy for FCA US Recall ID Z11 (NHTSA Recall ID 22V-077) completed. A folded or torn anode tab may result in the generation of lithium by-product over time. This defect, along with a second unidentified factor, may lead to an internal short within the pack and may result in a vehicle fire. A vehicle fire may increase the risk of injury to occupants and persons outside of the vehicle, as well as property damage.

FCA is advising owners of these hybrid vehicles to refrain from recharging the high voltage battery, and to park them away from structures and other vehicles until having Recall 73B (NHTSA Recall ID 24V-536) performed.

SCOPE

This recall applies only to the above vehicles equipped with a 3.6L PHEV Hybrid Engine (sales code EH3).

NOTE: Some vehicles above may have been identified as not involved in this recall and therefore have been excluded from this recall.

IMPORTANT:

- Some of the involved vehicles may be in dealer new vehicle inventory. Federal law requires you to complete this recall service on these vehicles before retail delivery. Violation of this requirement by a dealer could result in a civil penalty of up to \$27,168 per vehicle.
- Some of the involved vehicles may be in dealer used vehicle inventory. Dealers should complete this recall service on these vehicles before retail delivery.
- Dealers should also perform this recall on vehicles in for service.

Involved vehicles can be determined by using the VIP inquiry process.

REPAIR TO BE PERFORMED

IMPORTANT: Perform the Pre-Check BEFORE updating Battery Pack Control Module (BPCM) software.

Update the HV BPCM with revised software to monitor battery pack assembly operational status for conditions that could lead to a fire in the battery pack assembly. Then inspect and, if necessary, replace the battery pack assembly.

ALTERNATE TRANSPORTATION

Dealers should proactively minimize customer inconvenience while the recall repair is being performed. Reference the Goodwill Alternate Transportation Guidelines warranty bulletin link within Recall Central on DealerCONNECT for options to support the customer while their vehicle is in service.

COMPLETION REPORTING / REIMBURSEMENT

Claims for vehicles that have been serviced must be submitted on the DealerCONNECT Claim Entry Screen located on the Service tab. Claims paid will be used by FCA to record recall service completions and provide dealer payments.

Use the following labor operation numbers and time allowances:

Labor Description	Number	Hrs
Inspect/update BPCM Software. Then Perform BPCM integrity	18-73-B1-82	0.5
Inspect/update BPCM Software. Then Perform BPCM integrity, Replace High Voltage Battery Pack	18-73-B1-83	2.4

SAFETY RECALL

NORTH AMERICA

Plug-in Hybrid Electric Vehicle Fires



Reference: 73B / NHTSA 24V-536

FCA US LLC

Related Operation	Number	Hrs
Road Test ~ 1-6% Reduction in HV Battery State of Charge	18-73-B1-50	0.1
Road Test ~ 7-13% Reduction in HV Battery State of Charge	18-73-B1-51	0.2
Road Test ~ 14-19% Reduction in HV Battery State of Charge	18-73-B1-52	0.3
Road Test ~ 20-26% Reduction in HV Battery State of Charge	18-73-B1-53	0.4
Road Test ~ 27-32% Reduction in HV Battery State of Charge	18-73-B1-54	0.5
Battery Pack Control Module Cell Heating Period	18-73-B1-55	A/T

Add the cost of the recall parts plus applicable dealer allowance to your claim.

NOTE: See the Warranty Administration Manual, Recall Claim Processing Section, for complete recall claim processing instructions.

For Mobile Service Reimbursement, dealer to include standard dealer entry and mark-up for parts, standard dealer entry and labor rate for service, as well as the special services code for mobile allowance. The special services LOP will only be paid once per VIN and may NOT be used in coordination with any Alternate Transportation claims.

For additional details, reference the Mobile Service Warranty Bulletin - for convenience, a copy has been linked within Recall Central on DealerCONNECT.

PARTS INFORMATION

All parts required will be Ordered by STAR Center, once approved.

Very few vehicles are expected to require High Voltage Battery replacement.

NOTE: Please read and follow the I-Sheet instructions that are included with the replacement battery for unpacking upon receipt and packing for return of removed battery information.

PARTS RETURN

Return instructions for the old battery are included in the container with the new battery. There is a [REDACTED] core charge for this battery.

NOTE: Please read and follow the I-Sheet instructions that are included with the replacement battery for unpacking upon receipt and packing for return of removed battery information.

NOTE: If the battery return instructions are missing, a battery return I sheet can be downloaded from DealerCONNECT on the "Parts Tab" under the heading "Returns".

SPECIAL TOOLS

Number	Description
NPN	wiTECH MicroPod II / MDP
NPN	Laptop Computer
NPN	wiTECH Software
10441	Cone, Safety
10442	Barriers, Safety
10443	Cards, Windshield and Dash Placement
10452	Sign, Danger High Voltage
2035100082	Covers, HEV Battery Terminal
BX50-CHR	Table, Bishamon Lift
2035200080	Lift Straps, HEV Battery
126-1587	Meter, Fluke
ZEN4520	Lift, Wheel Jack Dolly

DEALER NOTIFICATION

To view this notification on DealerCONNECT, select "Global Recall System" on the Service tab, then click on the description of this notification.

OWNER NOTIFICATION / SERVICE SCHEDULING

All involved vehicle owners known to FCA are being notified of the service requirement by first class mail. They are requested to schedule appointments for this service with their dealers. A generic copy of the owner letter is attached.

SAFETY RECALL

NORTH AMERICA

Plug-in Hybrid Electric Vehicle Fires



Reference: 73B / NHTSA 24V-536

FCA US LLC

VEHICLE LISTS, GLOBAL RECALL SYSTEM, VIP AND DEALER FOLLOW UP

All involved vehicles have been entered into the DealerCONNECT Global Recall System (GRS) and Vehicle Information Plus (VIP) for dealer inquiry as needed.

GRS provides involved dealers with an updated VIN list of their incomplete vehicles. The owner's name, address and phone number are listed if known. Completed vehicles are removed from GRS within several days of repair claim submission.

To use this system, click on the "Service" tab and then click on "Global Recall System." Your dealer's VIN list for each recall displayed can be sorted by: those vehicles that were unsold at recall launch, those with a phone number, city, zip code, or VIN sequence.

Dealers must perform this repair on all unsold vehicles before retail delivery. Dealers should also use the VIN list to follow up with all owners to schedule appointments for this repair.

Recall VIN lists may contain confidential, restricted owner name and address information that was obtained from the Department of Motor Vehicles of various states. Use of this information is permitted for this recall only and is strictly prohibited from all other use.

ADDITIONAL INFORMATION

If you have any questions or need assistance in completing this action, please contact your Service and Parts District Manager.

Customer Services / Field Operations
FCA US LLC.

SAFETY RECALL

NORTH AMERICA

Plug-in Hybrid Electric Vehicle Fires



Reference: 73B / NHTSA 24V-536

FCA US LLC

SERVICE PROCEDURE

IMPORTANT: Perform the Pre-Check BEFORE updating Battery Pack Control Module (BPCM) Software.

A. Pre-Check 73B Battery Integrity Procedure

NOTE: The wiTECH scan tool must be used to perform this Safety Recall. The wiTECH software is required to be at the latest release level before performing this procedure.

1. Install a 12-Volt battery charger. Do not allow the charger to time out. Set the battery charger timer (if so equipped) to maintain 12-Volt continuous charge.

NOTE: The vehicle **MUST NOT** be connected to a high voltage battery charger.

2. Connect the wiTECH MDP to the vehicle data link connector.

NOTE: Same wiTECH MDP **MUST** be used throughout the procedure.

3. Place the ignition in the "RUN" position.
4. Open the wiTECH 2.0 website.
5. Enter your "User ID" and "Password" and your "Dealer Code", then select "Sign In" at the bottom of the screen. Click "Accept".
6. From the "Vehicle Selection" screen, select the appropriate vehicle.

NOTE: Obtain a Vehicle Scan Report VSR and ECU details report. Both must be provided to the STAR Center for High Voltage Battery replacement authorization.

- a) Create and save a Vehicle Scan Report VSR and ECU details report before proceeding. Both pre and post scan reports **will be required** for submission.
 - b) From the left column in the analysis section, select "Reports".
 - c) On the reports page, select "Vehicle Scan Report".
 - d) Repeat to obtain ECU details report.
 - e) Select "Printer Friendly" then save file type as "PDF". Name the file with the last eight digits of the VIN.
7. From the "Action Items" screen, select the "Topology" tab.
 8. Select "BPCM" icon.
 9. Select "System Test" tab.
 10. Select "BPCM 73B Remedy Pre-Check" then follow the wiTECH screen instructions to complete the routine. At the conclusion of the routine, wiTECH will advise the next step.

11. One of the following 2 screens will be displayed once the Pre-Check Procedure has finished.

PASS

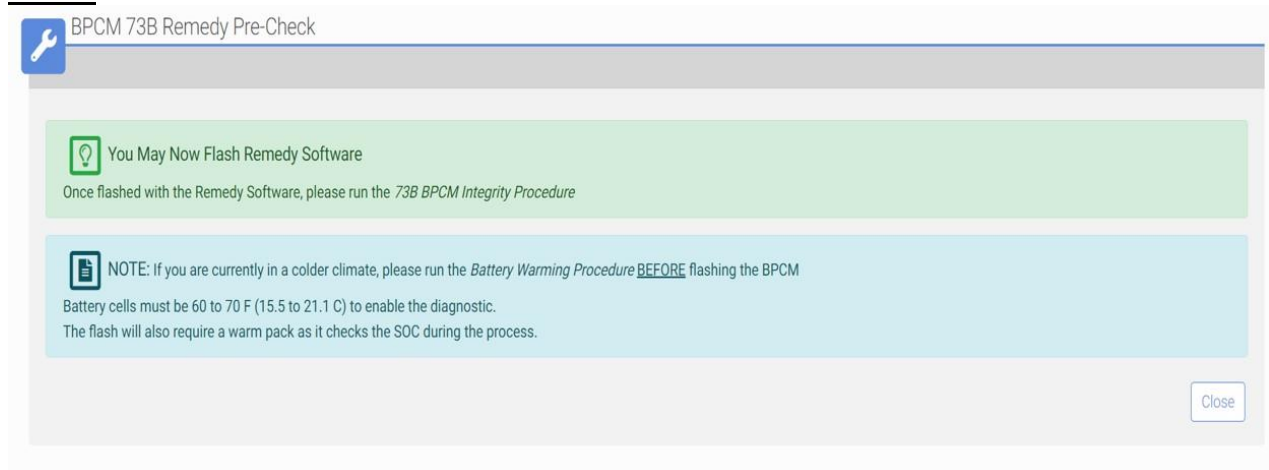

FAIL

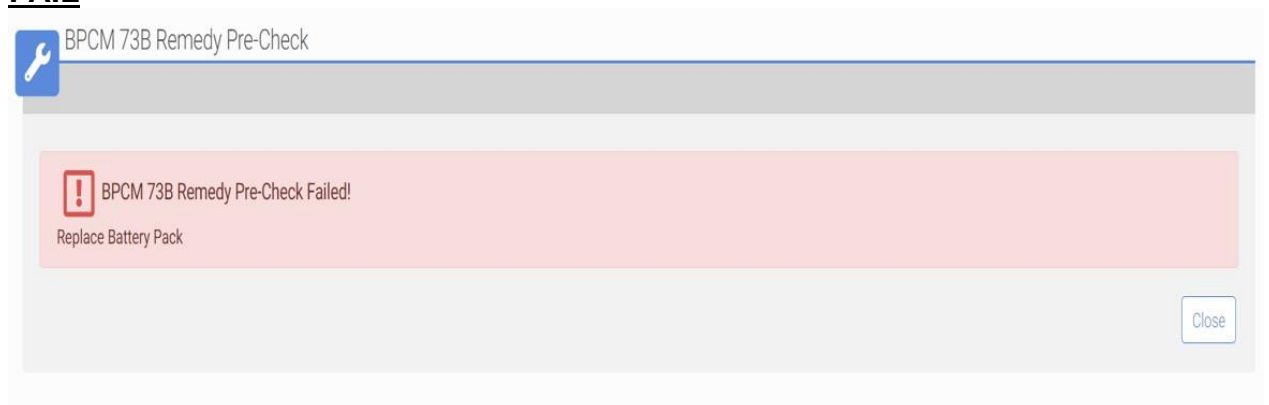

12. Pre-Check results:

- **PASS:** Proceed to **Section B. BPCM Warming Procedure.**
- **FAIL:** Proceed to **Section D. High Voltage Battery Pack Removal Procedure.**

SAFETY RECALL

NORTH AMERICA

Plug-in Hybrid Electric Vehicle Fires



Reference: 73B / NHTSA 24V-536

FCA US LLC

B. BPCM Warming Procedure

NOTE: Before beginning the following Service Procedure: Open the hood and start the engine then allow the engine to reach normal operating temperature. This may be performed outside before technician receives the vehicle. Once normal operation temperature is reached technician may begin the procedure.

NOTE: Verify the vehicle high voltage battery is at or BELOW 57% State-of-Charge (SOC) on the instrument cluster, if not already below 57% SOC drive the vehicle to discharge the high voltage battery. DO NOT allow vehicle engine to run for a long period after the high voltage battery has been discharged, doing so will recharge the battery.

NOTE: The wiTECH scan tool must be used to perform this BPCM Warming Procedure.

1. Install a battery charger. Do not allow the charger to time out during the flash process. Set the battery charger timer (if so equipped) to maintain 12-Volt continuous charge.
2. Connect the wiTECH micro pod II to the vehicle data link connector.

NOTE: Same wiTECH micro pod II MUST be used throughout the procedure.

3. Place the ignition in the “**RUN**” position.
4. Open the wiTECH 2.0 website.
5. Enter your “**User id**” and “**Password**” and your “**Dealer Code**”, then select “**Sign In**” at the bottom of the screen. Click “**Accept**”.
6. From the “**Vehicle Selection**” screen, select the vehicle to be updated.
7. From the “**Action Items**” screen, select the “**Topology**” tab.
8. From the “**Topology**” tab, select the “**BPCM**” module icon.

SAFETY RECALL

NORTH AMERICA

Plug-in Hybrid Electric Vehicle Fires



Reference: 73B / NHTSA 24V-536

FCA US LLC

9. Within BPCM, select “**System Tests**” then select “**BPCM Warming Procedure**” then select “**Continue**”.

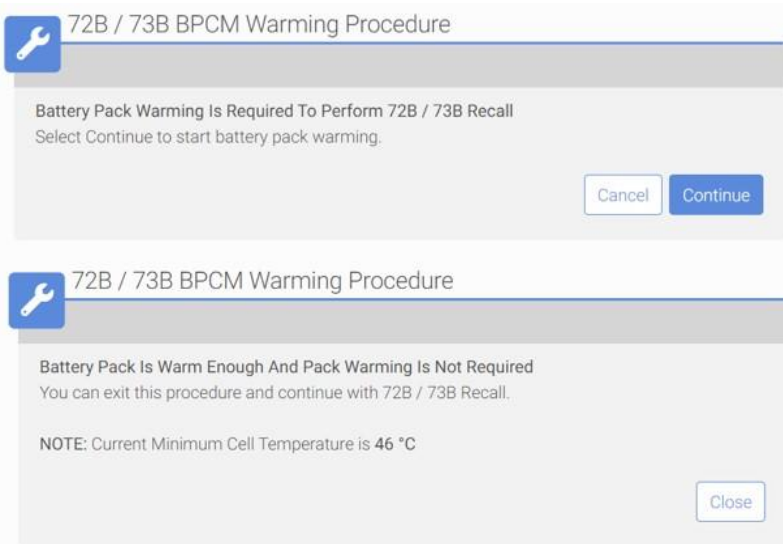

NOTE: Ensure the vehicle hood is open and remains open or the BPCM warming procedure will abort.

SAFETY RECALL
 NORTH AMERICA
Plug-in Hybrid Electric Vehicle Fires



Reference: 73B / NHTSA 24V-536

FCA US LLC

10. Follow the wiTECH screen instruction steps to perform the BPCM warming procedure if directed, otherwise proceed to Section C. Battery Pack Control Module (BPCM) Software Update and BPCM Integrity Procedure.

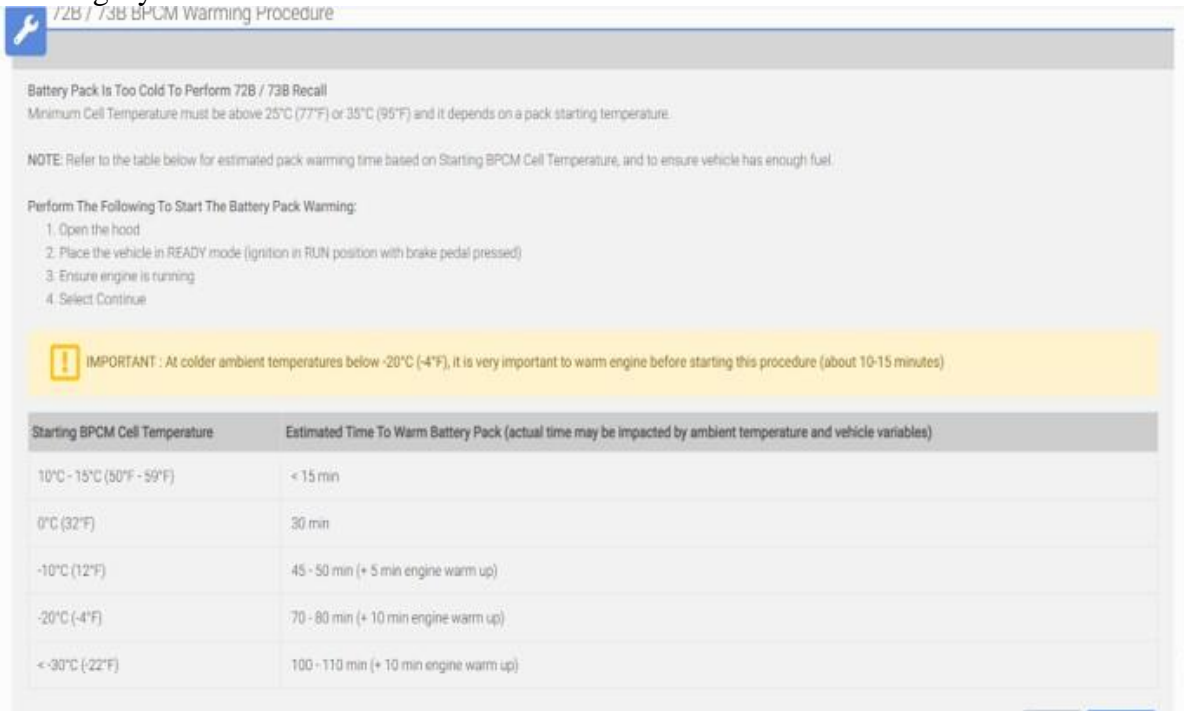

11. BPCM cell warming period duration will require separate technician time punch. BPCM cell warming duration will be recorded and traced by wiTECH 2. Individual punch time must reflect actual BPCM cell warming period or claim will be rejected or charged back to dealership.
12. The following data will be displayed during the warming procedure.

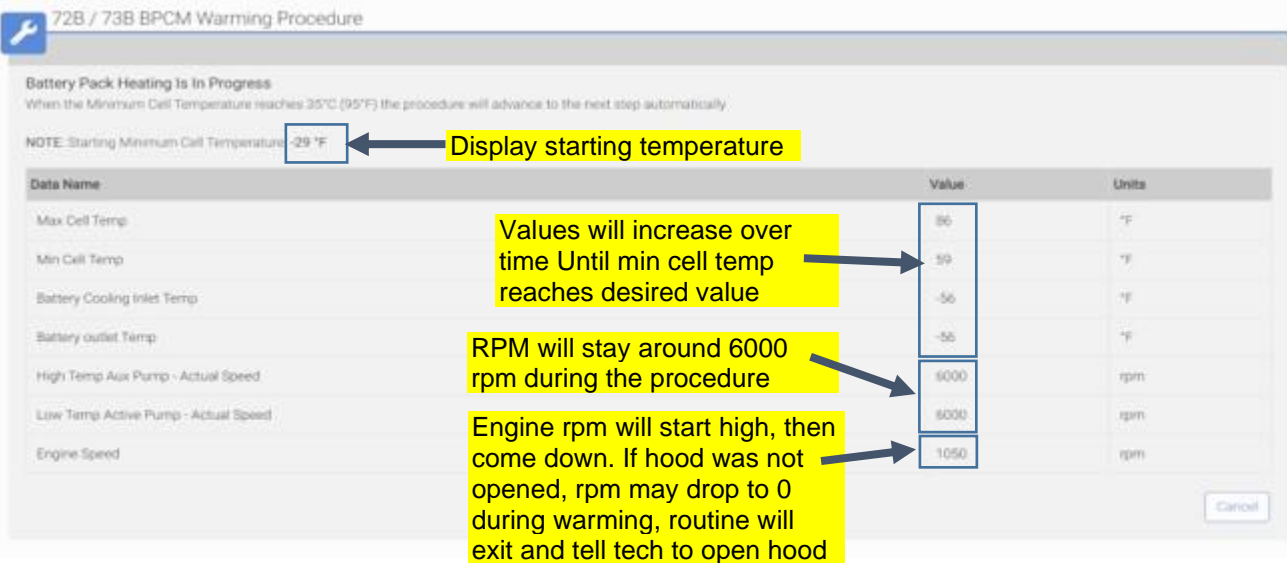

Strictly respect STELLANTIS Group safety, cleanliness, and environmental instructions for any vehicle service. Document exclusively reserved for dealer information. Internal distribution to be ensured by dealer. Reproduction forbidden without the written agreement of STELLANTIS Group. (C) 2024 STELLANTIS Group. All Rights Reserved (tdb)

SAFETY RECALL

NORTH AMERICA

Plug-in Hybrid Electric Vehicle Fires



Reference: 73B / NHTSA 24V-536

FCA US LLC

NOTE: During the BPCM warming procedure, if the high voltage battery reaches near full state of charge, the vehicle engine may exhibit a bucking or jerking while running. This is normal as the charging system switches modes in order to prevent over charging the battery.

- 13. The following will be displayed once warming procedure has completed. Perform the steps listed on the screen before continuing.



- 14. One of the following 3 screens will be displayed once the warming procedure has finished.

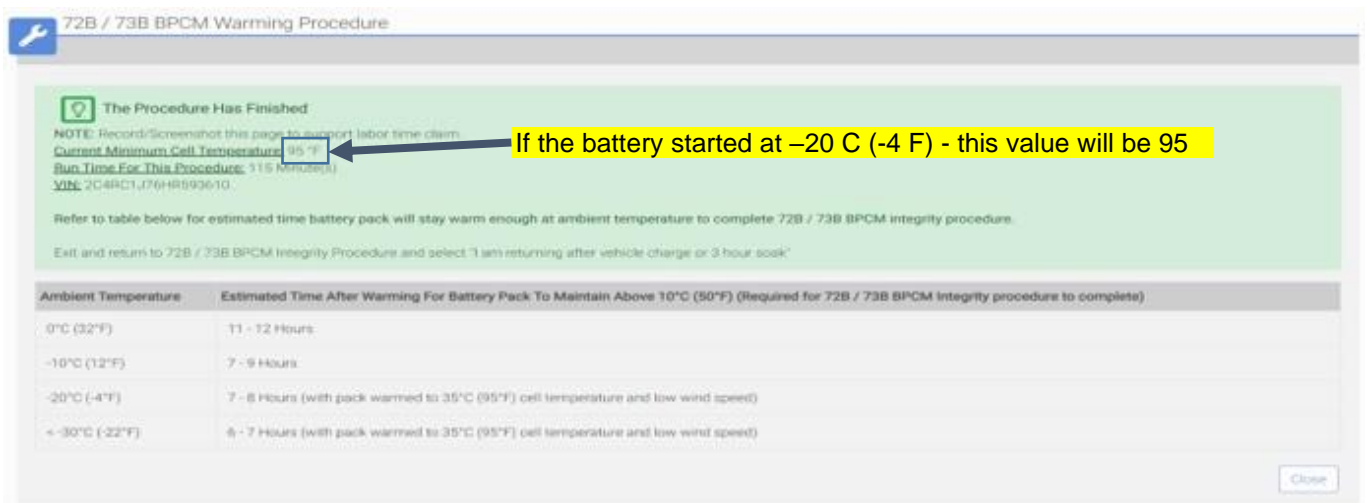

SAFETY RECALL
 NORTH AMERICA
Plug-in Hybrid Electric Vehicle Fires



Reference: 73B / NHTSA 24V-536

FCA US LLC

72B / 73B BPCM Warming Procedure

The Procedure Has Finished

NOTE: Record/Screenshot this page to support labor time claim.
 Current Minimum Cell Temperature: 95.7°
 Run Time For This Procedure: 115 Minutes(s)
 VIN: 2C4RC1J76HR593610

If the battery started at -20 C (-4 F) - this value will be 95

Refer to table below for estimated time battery pack will stay warm enough at ambient temperature to complete 72B / 73B BPCM integrity procedure.
 Exit and continue with the next 72B / 73B Recall step (BPCM flash)

Ambient Temperature	Estimated Time After Warming For Battery Pack To Maintain Above 10°C (50°F) (Required for 72B / 73B BPCM integrity procedure to complete)
0°C (32°F)	11 - 12 Hours
-10°C (12°F)	7 - 9 Hours
-20°C (-4°F)	7 - 8 Hours (with pack warmed to 35°C (95°F) cell temperature and low wind speed)
< -30°C (-22°F)	6 - 7 Hours (with pack warmed to 35°C (95°F) cell temperature and low wind speed)

Close

72B / 73B BPCM Warming Procedure

The Procedure Has Finished

NOTE: Record/Screenshot this page to support labor time claim.
 Current Minimum Cell Temperature: 95.7°
 Run Time For This Procedure: 115 Minutes(s)
 VIN: 2C4RC1J76HR593610

If the battery started at -20 C (-4 F) - this value will be 95

Refer to table below for estimated time battery pack will stay warm enough at ambient temperature to complete 72B / 73B BPCM integrity procedure.
 The Pack SOC Must Be Below 50% To Continue With 72B / 73B Recall
 Exit and drive the vehicle until SOC drops below 50% in the cluster.
 When finished with the drive continue with the next 72B / 73B Recall step (BPCM flash)

Ambient Temperature	Estimated Time After Warming For Battery Pack To Maintain Above 10°C (50°F) (Required for 72B / 73B BPCM integrity procedure to complete)
0°C (32°F)	11 - 12 Hours
-10°C (12°F)	7 - 9 Hours
-20°C (-4°F)	7 - 8 Hours (with pack warmed to 35°C (95°F) cell temperature and low wind speed)
< -30°C (-22°F)	6 - 7 Hours (with pack warmed to 35°C (95°F) cell temperature and low wind speed)

Close

- Once the warming procedure has finished, proceed to **Section C. Battery Pack Control Module (BPCM) Software Update and BPCM Integrity Procedure.**

C. Battery Pack Control Module (BPCM) Software Update and BPCM Integrity Procedure

ALERT: This recall procedure REQUIRES you to reach the below screen message within the BPCM Integrity Procedure before returning the vehicle to a customer:

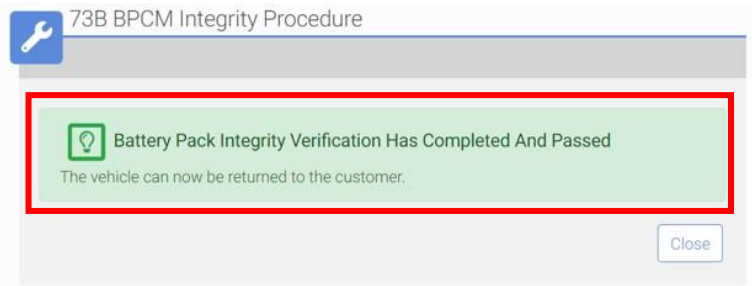

ALERT: Performing the BPCM flash will illuminate and continuously flash the Hybrid Electric Vehicle System Service lamp located in the instrument panel cluster. Every step in the 73B BPCM Integrity Procedure MUST be completed in order to turn the flashing service lamp off.

Do not return the vehicle to the customer if the service lamp is flashing. (Figure 1).

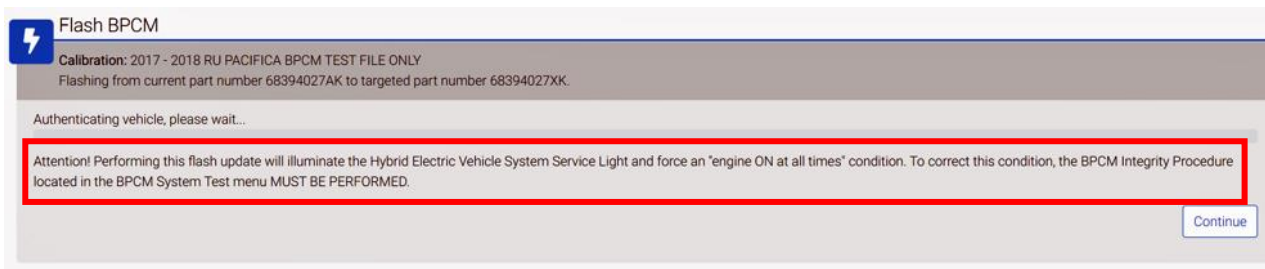

Figure 1 – Service Light

SAFETY RECALL

NORTH AMERICA

Plug-in Hybrid Electric Vehicle Fires



Reference: 73B / NHTSA 24V-536

FCA US LLC

NOTE: Verify the vehicle high voltage battery is at or BELOW 57% State-of-Charge (SOC) on the instrument cluster, if not already below 57% SOC drive the vehicle to discharge the high voltage battery. DO NOT allow vehicle engine to run for a long period after the high voltage battery has been discharged, doing so will recharge the battery.

NOTE: The wiTECH scan tool must be used to perform this safety recall. If the BPCM reprogramming is aborted or interrupted during reprogramming, it must be restarted. The BPCM software must be at the latest software calibration level after completing this safety recall.

1. From the “**Topology**” tab, select “**ALL DTCs**” then “**Clear All**”. If any fault code(s) are present, repair as directed in the service manual procedure. If there are no active fault code(s) proceed to **Step 2**.
2. From the “**Topology**” tab, select the “**BPCM**” module icon.
3. From the “**Flash**” tab, compare the “**Current Electronic Control Unit (ECU) Part Number**” with the “**New ECU Part Number**” listed.
 - If the “**Current ECU part Number**” is the same as the “**New Part Number**”, proceed to **Step 10**.
 - If the “**Current ECU part Number**” is NOT the same as the “**New Part Number**”, continue with **Step 4**.
4. From the BPCM tab, select the latest BPCM flash part number. Read the flash special instructions page. Select “**OK**” to continue.
5. From the flash ECU agreement page, agree to terms by checking the box.
6. Select “**Flash ECU**” and then follow the wiTECH screen instructions to complete the flash.
7. Confirm the software is at the latest available calibration level.
8. Cycle the ignition to the “**Off**” position, then to the “**On**” position.
9. Click “**View DTCs**”, select “**Clear All DTCs**”, click “**Continue**” and then click “**Close**”.
10. Place the ignition in the “**OFF**” position.

SAFETY RECALL

NORTH AMERICA

Plug-in Hybrid Electric Vehicle Fires



Reference: 73B / NHTSA 24V-536

FCA US LLC

11. Remove the 12-volt battery charger from the vehicle.
12. Close the vehicle hood, doors and windows.
13. Place the ignition in the “RUN” position.
14. Confirm the vehicle high voltage battery is at **57%** State-of-Charge (SOC) or less on the instrument cluster, if not already below **57%** drive the vehicle to discharge the high voltage battery.

NOTE: Do not leave engine running once the battery has been discharged, this may recharge the battery

NOTE: It is important to disable the Charging Schedule on the display. Failure to disable the charging schedule may require restarting the procedure.

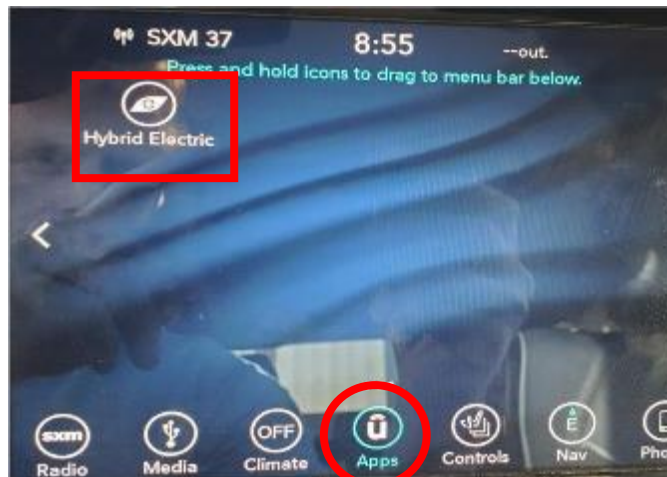

Figure 1 – Apps Display Screen

15. Select “Apps” then “Hybrid Electric” on the display (Figure 1).



Figure 2 – Charging Schedule Display

16. Select “Charging Schedule” (Figure 2).

SAFETY RECALL

NORTH AMERICA

Plug-in Hybrid Electric Vehicle Fires



Reference: 73B / NHTSA 24V-536

FCA US LLC

17. Verify the “Check Mark” is **NOT** selected in the “Enable Schedule” box (Figure 3).

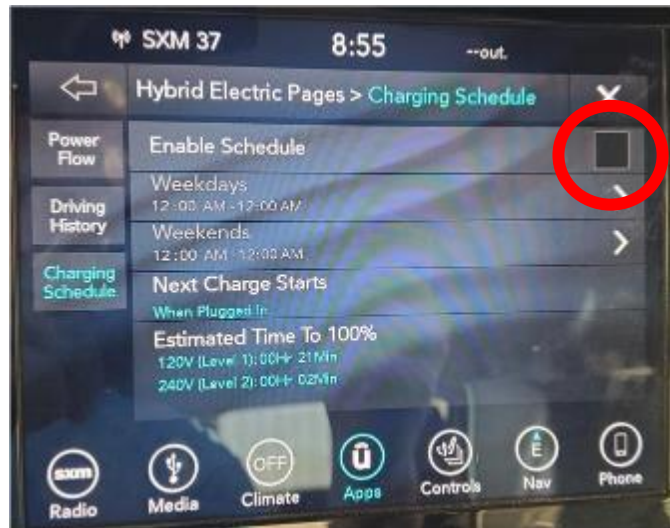

Figure 3 – Enable Schedule Screen

18. Park the vehicle next to an **OUTDOOR** Level 2 High Voltage Battery charger.

PREPARE THE WORK AREA

- Assemble the six Cone, Safety 10441 and six **Barriers, Safety 10442** around the vehicle/hoist area.
 - Position the two Sign, **Danger High Voltage 10452** within the assembled safety cones and barriers.
 - Place the four Cards, **Windshield and Dash Placement 10443** within the vehicle.
 - Create and tape a **DO NOT DISTURB** sign on driver’s door handle and near charge port.
19. Open the wiTECH 2.0 website.
20. Enter your “**User id**” and “**Password**” and your “**Dealer Code**”, then select “**Sign In**” at the bottom of the screen. Click “**Accept**”.
20. From the “**Vehicle Selection**” screen, select the vehicle to be updated.
22. From the “**Action Items**” screen, select the “**Topology**” tab.
23. Select “**BPCM**” Icon.

SAFETY RECALL

NORTH AMERICA

Plug-in Hybrid Electric Vehicle Fires



Reference: 73B / NHTSA 24V-536

FCA US LLC

24. Select “System Test” tab.
25. Select **73B BPCM Integrity Procedure**.
26. Select test “**I am Starting from beginning**” and begin procedure.
27. Follow screen prompts displayed in the wiTECH routine. Charge the High Voltage Battery to a **full charge and allow a rest period, as directed by the wiTECH routine** (up to 7 hrs. total) based on SOC and rate of charger input. *Do Not Attempt to Return Earlier Than Directed*.

NOTE: Verify charger is charging by viewing the lights flashing on the dashboard, if only the 2 outer bars are illuminated, charger is not enabled restart the charging process.

28. Disconnect the wiTECH micro pod II from the vehicle data link connector.
29. Place the ignition in the “OFF” position.

CAUTION: If charging indoors is unavoidable (not preferred). Do not leave the vehicle unattended while charging. If any smoke is observed coming from the underbody, unplug the charge cable and, if safe to do so, slide the Lift, Wheel Jack Dolly under both front wheels (See Figure 4 and 5) elevate the vehicle and push it outside away from buildings and other vehicles. Call your local fire department immediately.



Figure 4 – Lift, Wheel Jack Dolly



Figure 5 – Wheel Jack Dolly Installed

SAFETY RECALL

NORTH AMERICA

Plug-in Hybrid Electric Vehicle Fires



Reference: 73B / NHTSA 24V-536

FCA US LLC

CAUTION: Vehicles involved in this recall should NOT be left connected to a charger after business hours.

NOTE: Any of the below interruptions will require restarting the routine.

- **DO NOT** Disturb Vehicle while charging the High Voltage Battery
- **DO NOT** disconnect charge cable from charge port while charging
- **DO NOT** open any doors
- Observe the LED Charge Indicator on dash to verify charge status
- Lock doors and remove the key fob and set aside away from the vehicle

NOTE: It is critical that step 30 is completed in a timely manner; within 1 minute. Step 30 and step 31 must be completed in the exact order listed. Failure to complete these steps in order may result in requiring the test to be re-performed.

30. Only after the full time has passed, return to the vehicle. Using the key fob unlock then open the driver door and quickly place the ignition in the “**RUN**” position.
31. Connect the wiTECH micro pod II to the vehicle data link connector.
32. Open the wiTECH 2.0 website.
33. Enter your “**User id**” and “**Password**” and your “**Dealer Code**”, then select “**Sign In**” at the bottom of the screen. Click “**Accept**”.
34. From the “**Vehicle Selection**” screen, select the vehicle to be updated.
35. From the “**Topology**” tab, select the “**BPCM**” module icon.
36. Select “**System Test**” tab.
37. Select **73B BPCM Integrity Procedure**.
38. Select test “**I Am Returning After Vehicle Charge Or 3 Hour Soak**” and begin procedure.
39. Follow all screen prompts until completed. If the wiTECH Routine indicates the High Voltage Battery requires replacement, follow section: **C. High Voltage Battery Pack Removal Procedure** otherwise, proceed to Step 40.

SAFETY RECALL

NORTH AMERICA

Plug-in Hybrid Electric Vehicle Fires



Reference: 73B / NHTSA 24V-536

FCA US LLC

NOTE: High voltage battery pack must **maintain not less than (50°F)(10°C) temperature environment during testing** and wiTECH routine, **failure to maintain the temperature may cause repeat testing.**

40. Allow the vehicle to rest an additional **3hrs** (or longer) after **completing charge**. **Do not drive vehicle a long distance.**

NOTE: It is critical that **step 41 is completed in a timely manner; within 1 minute. Step 41 and step 42 must be completed in the exact order listed. Failure to complete these steps in order may result in requiring the test to be re-performed.**

41. Open the driver door and quickly place the ignition in the “**RUN**” position.
42. Connect the wiTECH micro pod II to the vehicle data link connector.
43. Open the wiTECH 2.0 website.
44. Enter your “**User id**” and “**Password**” and your “**Dealer Code**”, then select “**Sign In**” at the bottom of the screen. Click “**Accept**”.
45. From the “**Vehicle Selection**” screen, select the vehicle to be updated.
46. From the “**Topology**” tab, select the “**BPCM**” module icon.
47. Select “**System Test**” tab.
48. Select **73B BPCM Integrity Procedure**.
49. Select test “**I Am Returning After Vehicle Charge Or 3 Hour Soak**” and begin procedure. (**NOTE: This is the final selection**)
50. Follow all screen prompts until test is completed.
51. You **MUST** reach the wiTECH routine screen advising the vehicle can now be returned to the customer.
52. If no DTCs are present, remove the wiTECH micro pod II device from the vehicle. If the wiTECH Routine indicates the High Voltage Battery requires replacement, follow section: **D. High Voltage Battery Pack Removal Procedure.**

SAFETY RECALL

NORTH AMERICA

Plug-in Hybrid Electric Vehicle Fires



Reference: 73B / NHTSA 24V-536

FCA US LLC

D. High Voltage Battery Pack Removal Procedure

NOTE: A Vehicle Scan Report VSR and ECU details report must be provided to the STAR Center for High Voltage Battery replacement authorization.

- a) Create and save a Vehicle Scan Report VSR and ECU details report before proceeding. Both pre and post scan reports **will be required** for submission.
- b) From the left column in the analysis section, select “**Reports**”.
- c) On the reports page, select “**Vehicle Scan Report**”.
- d) Repeat to obtain ECU details report.
- e) Select “**Printer Friendly**” then save file type as “**PDF**”. Name the file with the last eight digits of the vehicle VIN.

WARNING: Before performing any diagnostic or service procedure, you must thoroughly read and follow all applicable high voltage safety procedures. You must perform the high voltage power down procedures.

Loss of Isolation (LOI) must be performed before high voltage power up in cases where service has been performed on a high-voltage component or when diagnosing a LOI condition.

Be sure to use the proper safety equipment when working on any high voltage system or component. Failure to do so may result in serious or fatal injury.

Wait a minimum of two minutes after performing the high voltage battery disconnect procedure safety procedures before attempting to access the high voltage system, failure to do so may result in serious or fatal injury.

NOTE: Observe the following precautions when handling the high-voltage battery pack:

SAFETY RECALL

NORTH AMERICA

Plug-in Hybrid Electric Vehicle Fires



Reference: 73B / NHTSA 24V-536

FCA US LLC

- **Do not** touch the high voltage terminals.
- Always use four lift points when moving the battery pack.
- Keep the battery pack in an upright position.
- Store in a clean and dry environment.
- Store at a temperature of 10°-30°C (50°-86°F) with relative humidity between 30-70%.
- Always store at a State-of-Charge (SOC) of around 30%.
- Always store on an electrically non-conducting (insulated) material.
- Store with spatial gap of at least 50 cm (20 in.).
- **Do not** store the battery pack near any environmental condition involving liquid, heat, strong magnetic field, electricity or that can generate heat (for example: transformers).

NOTE: When performing any repairs that involve contact with high voltage components or systems, the technician performing repairs on the vehicle must verify that the system remains powered down during high voltage repairs.

- This must be done by removing the service disconnect.
- The high voltage power down procedure must also be performed to ensure that the vehicle is properly powered down.
- The technician must know the whereabouts of the service disconnect throughout the repair.
- The technician must ensure that no one reconnects the service disconnect while service is being performed.
- The technician must recheck that the service disconnect has not been reinstalled in cases where the vehicle was unattended.

SAFETY RECALL

NORTH AMERICA

Plug-in Hybrid Electric Vehicle Fires



Reference: 73B / NHTSA 24V-536

FCA US LLC

1. Prepare the work area and familiarize yourself with all HIGH-VOLTAGE SAFETY PROCEDURES related to personal safety and vehicle safety associated with working on a Plug-In Hybrid Electric Vehicle (PHEV) (Refer to 08 - Electrical/Standard Procedure).
2. Inspect all orange high-voltage cables, and high-voltage components labeled with the high-voltage symbol for physical damage. If damage is present, extra caution must be taken to avoid contact with unprotected high-voltage. Do not insert probes, tools, objects or fluids into damaged high-voltage cables or components.
3. Disconnect any charging equipment, turn off the ignition, remove the keys, open the hood and leave the vehicle doors open.
4. Remove the air cleaner body.
5. Use of an insulation tester such as the Fluke Meter, Multi 126-1587 is recommended for PHEV circuit testing. Perform the multi-meter functionality tests per the manufacture's directions. Verify the multi-meter is operating correctly by measuring voltage from a known good power source, such as the vehicle's 12-volt battery. If at any point during the procedure, the multi-meter settings are changed, or the probes are repositioned in the meter, verification with a known good power source must be repeated.

NOTE: Before performing step 6, verify the CAN C bus is asleep before removing the positive battery cable from the Power Distribution Center (PDC). Failure to do so may result in fault codes.

6. Disconnect the B+ battery cable (1) from the 12-volt Power Distribution Center (PDC) (Figure 6).
7. Isolate the battery cable terminal with Cover, Protective 10084



Figure 6 – Battery Cable

SAFETY RECALL

NORTH AMERICA

Plug-in Hybrid Electric Vehicle Fires



Reference: 73B / NHTSA 24V-536

FCA US LLC

NOTE: Wait a minimum of 2 minutes before removing the manual service disconnect.

8. Lift the carpet away from the high-voltage MSD floor access cover.
9. Remove the four screws (2) and remove the high-voltage MSD access cover (1) (Figure 7).
10. Depress the lever release latch (2) firmly. With the latch fully depressed, rotate the lever (1) upward. The lever will stop at the 45° position (Figure 7).



Figure 7 – MSD Access Cover

NOTE: At this stage, the High Voltage Inter-Lock (HVIL) connection has been broken and the circuit is de-energized.

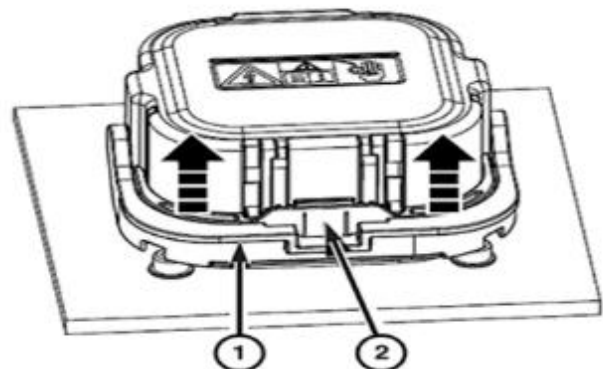

Figure 3 – MSD Latch

11. Again, depress the locking tab (2) and continue to rotate the lever to the end of travel (90° position) (Figure 8).
12. Pull straight back on the plug lever (1) to disengage and remove the high-voltage manual service disconnect from the receptacle (Figure 9).

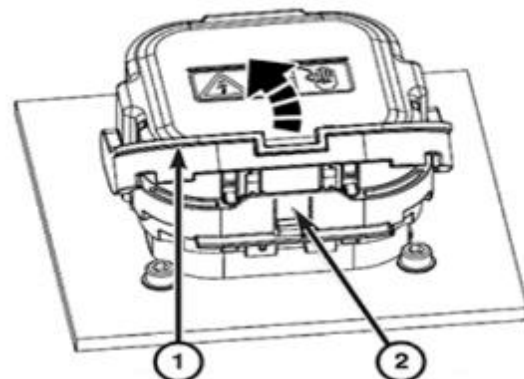

Figure 8 – MSD Locking Tab

SAFETY RECALL

NORTH AMERICA

Plug-in Hybrid Electric Vehicle Fires



Reference: 73B / NHTSA 24V-536

FCA US LLC

13. Cap the receptacle on the high-voltage battery with the [Covers, HEV Battery Terminal 2035100082](#) (1) to prevent foreign objects from entering (Figure 10).

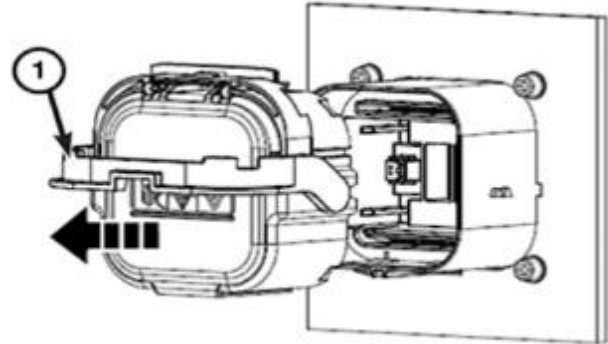

Figure 9 – MSD Removal

NOTE: Make sure the location of the high-voltage MSD is always known; after removal, it is best practice to place the high-voltage MSD in a highly visible location.



Figure 10 – MSD Cover

SAFETY RECALL

NORTH AMERICA

Plug-in Hybrid Electric Vehicle Fires



Reference: 73B / NHTSA 24V-536

FCA US LLC

NOTE: Always wear HV gloves and safety glasses for the next two steps

14. Loosen two captive screws (1) and remove the single High Voltage Inter-Lock (HVIL) connector from the Power Inverter Module (PIM) cover (Figure 11).

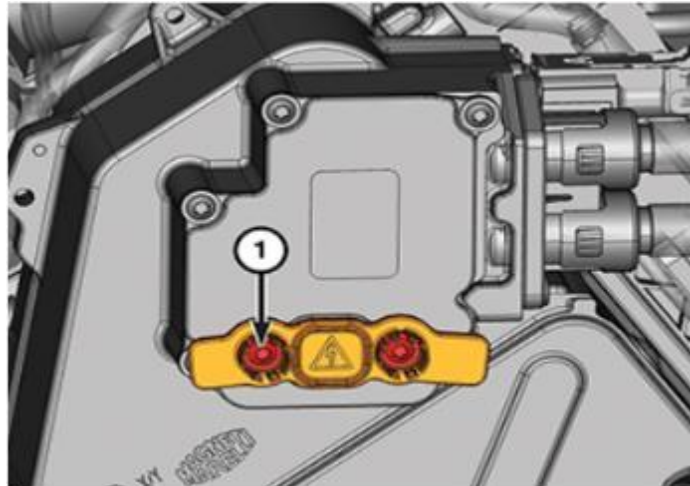

Figure 11 – Power Inverter Module

15. Loosen five captive screws (1) and remove the PIM cover (Figure 12).

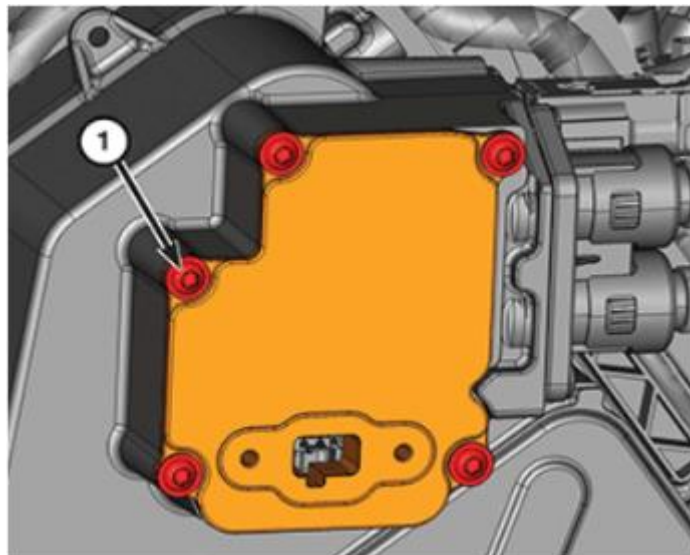

Figure 12 – PIM Cover

SAFETY RECALL

NORTH AMERICA

Plug-in Hybrid Electric Vehicle Fires



Reference: 73B / NHTSA 24V-536

FCA US LLC

NOTE: Always observe these precautions prior to taking a high-voltage measurement:

- **Have known good test leads.**
 - **Set the range to no decimal points.**
 - **Read a known good low-voltage source first.**
 - **High voltage Personnel Protection Equipment (PPE) must be worn.**
16. Measure the voltage at the PIM high voltage terminals:
- Measure between the positive and negative high voltage terminals.
 - Measure between each high voltage terminal and chassis ground.
17. The measured voltage should be near 0 volts (Figure 13).
- If the voltage measured is near 0 volts, it is safe to work on the high-voltage components with the exception of the high-voltage battery internal components.
 - If the voltage is greater than 0 volts, an internal condition exists within the high-voltage battery that is preventing it from being powered down. Do not attempt to carry out repairs on any of the vehicle's high-voltage components or wiring. Perform the **HIGH VOLTAGE LOSS OF ISOLATION TEST PROCEDURE** (Refer to 08 - Electrical/Standard Procedure)
18. After confirming that the high voltage battery is powered down and locked out it is safe to power up the **12-volt system** if needed to perform diagnostics or repairs.



Figure 13 – Voltage Measurement

SAFETY RECALL

NORTH AMERICA

Plug-in Hybrid Electric Vehicle Fires



Reference: 73B / NHTSA 24V-536

FCA US LLC

19. Raise and support the vehicle.
20. Remove the engine belly pan, charger belly pan, battery belly pan and rear suspension belly pan.
21. Using suitable hose-pinching pliers, clamp-closed the coolant inlet (1) and outlet (2) hoses near the high-voltage battery (Figure 14).

CAUTION: Do not allow coolant to come in contact with any high voltage component electrical connections. Engine coolant will create a conductive path and cannot be effectively removed resulting in a loss of isolation and replacement of the contaminated high voltage component.

22. Place a suitable coolant recovery container under the coolant inlet and outlet hoses.
23. Disengage the quick-connect couplings and carefully remove the coolant inlet (1) and outlet (2) hoses from the high voltage battery (Figure 15).

NOTE: Not all coolant will drain from the high voltage battery.

24. If all coolant must be removed, as in the case of a high voltage battery replacement, use a shop air supply hose connected to the battery coolant inlet port (1). Adjust the air pressure regulator to not exceed 100 kPa (15 psi) and force the coolant from the battery coolant outlet port (2).

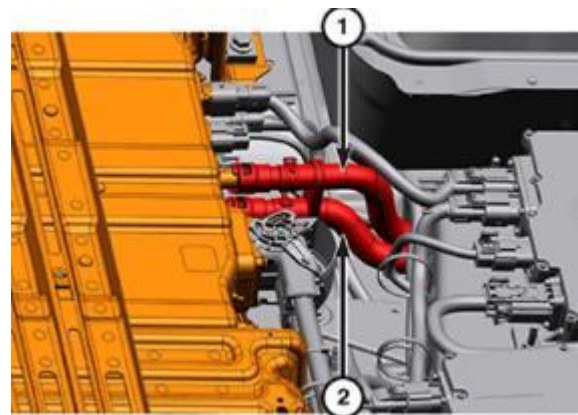

Figure 14 – Coolant Hoses

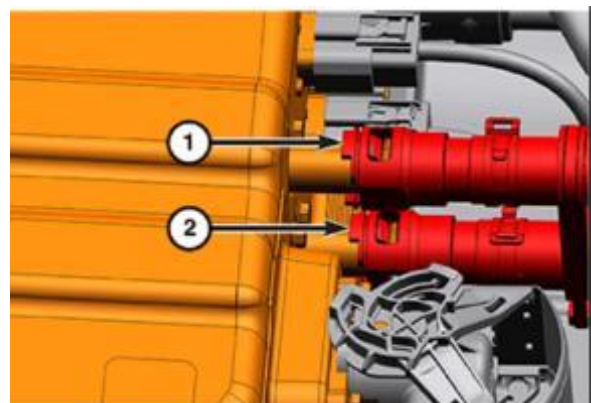

Figure 15 – Quick Connect Couplings

SAFETY RECALL

NORTH AMERICA

Plug-in Hybrid Electric Vehicle Fires



Reference: 73B / NHTSA 24V-536

FCA US LLC

25. Cap the nipples on the high-voltage battery with the [Covers, HEV Battery Terminal 2035100082](#) and plug the coolant hose ends.
26. Disengage the two wire harness retainers (2) from the high-voltage battery (Figure 16).
27. Unlock and disconnect the Power Inverter Module (PIM) high-voltage wire harness connector (1) from the high-voltage battery. Cap the connector on the high-voltage battery with the [Covers, HEV Battery Terminal 2035100082](#)
28. Unlock and disconnect the low-voltage wire harness connectors (1) from the high-voltage battery (Figure 17).
29. Unlock and disconnect the On-board Charging Module (OBCM) and Electric Coolant Heater (ECH) high-voltage wire harness connectors (2) from the high-voltage battery.
30. Cap the connectors on the high-voltage battery with the [Covers, HEV Battery Terminal 2035100082](#).

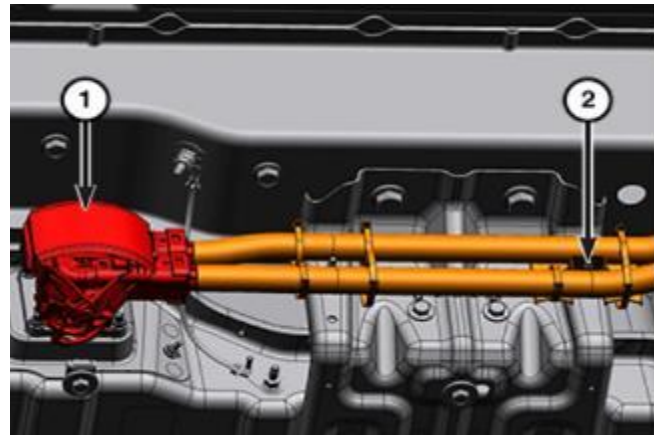

Figure 16 – Wire Harness

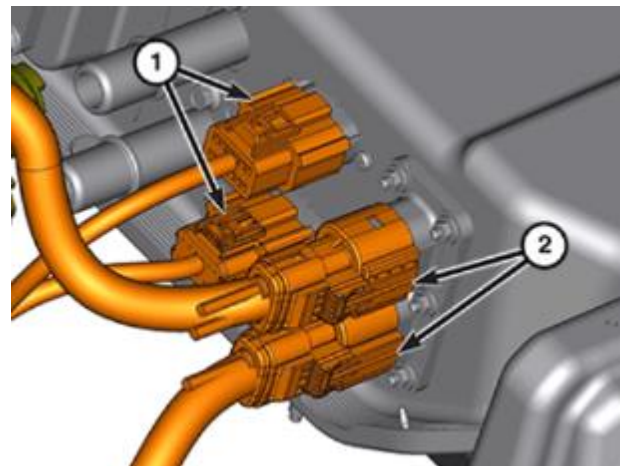

Figure 17 – Wire Harness

SAFETY RECALL

NORTH AMERICA

Plug-in Hybrid Electric Vehicle Fires



Reference: 73B / NHTSA 24V-536

FCA US LLC

31. Remove the nut (1) and the chassis ground cable from the high-voltage battery ground stud (2) (Figure 18).

32. Position a suitable lifting device, such as [Table, Bishamon Lift BX50-CHR](#), under the high-voltage battery pack. Secure the high-voltage battery pack to the lifting device.

NOTE: The high-voltage battery pack weighs 167 kg (368 lb.).

33. Remove the eight bolts and remove the high-voltage battery from the vehicle.
34. Remove the nuts (1) and the heat shield from the high-voltage battery (Figure 19).

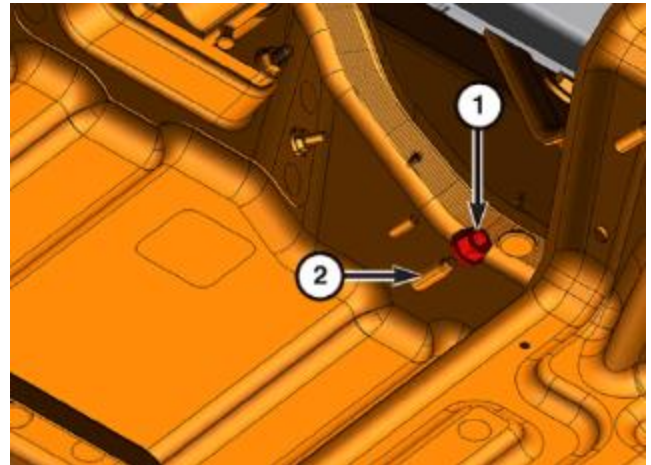

Figure 18 - Ground Stud and Nut

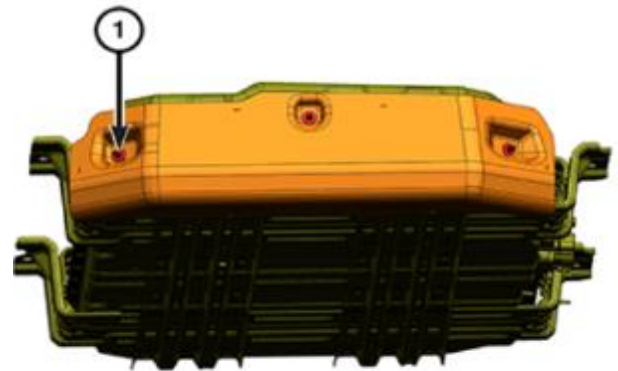

Figure 19 – Heat Shield

SAFETY RECALL

NORTH AMERICA

Plug-in Hybrid Electric Vehicle Fires



Reference: 73B / NHTSA 24V-536

FCA US LLC

35. Install the [Lift Straps, HV Battery 2035200080](#) (1) and remove the high-voltage battery pack from the lifting device. Place the high-voltage battery pack in the shipping container or in a suitable storage location (Figure 20).

NOTE: If the high-voltage battery pack is being replaced;

- The Manual Service Disconnect (MSD) from this battery must be retained and returned with the battery.
- All coolant must be removed from the battery. Use a shop air supply hose connected to the battery coolant inlet port. Adjust the air pressure regulator to not exceed 100 kPa (15 psi) and force the coolant from the battery coolant outlet port.
- All coolant ports and electrical connections must be capped.

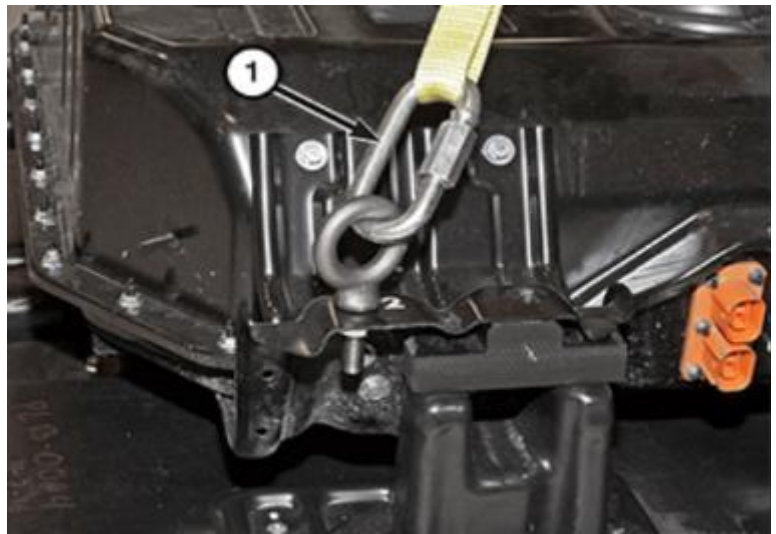

Figure 20 – Lift Straps

CAUTION: Do not allow coolant to come in contact with any high voltage component electrical connections. Engine coolant will create a conductive path and cannot be effectively removed resulting in a loss of isolation and replacement of the contaminated high voltage component.

NOTE: If the High Voltage battery is missing its return instructions, contact the UPS Call Center 800-567-9989.

SAFETY RECALL

NORTH AMERICA

Plug-in Hybrid Electric Vehicle Fires



Reference: 73B / NHTSA 24V-536

FCA US LLC

D. High Voltage Battery Pack Installation Procedure.

1. Install the [Lift Straps, HV Battery 2035200080](#) and place the high-voltage battery pack on a suitable lifting device, such as [Table, Bishamon Lift BX50-CHR](#). Secure the high-voltage battery pack to the lifting device.

NOTE: The high-voltage battery pack weighs 167 kg (368 lb.).

2. Install the heat shield to the high-voltage battery and securely tighten the nuts.
3. Install the high-voltage battery pack in the vehicle and tighten the eight bolts to 48 N·m (35ft. lbs.)
4. Install the chassis ground cable to the high-voltage battery ground stud (2) and tighten the nut to 9 Nm (80In. lbs.).
5. Remove the low-voltage battery port covers, connect and lock the low-voltage wire harness connectors to the high-voltage battery.
6. Remove the high-voltage battery port covers, connect and lock the On-board Charging Module (OBCM) and Electric Coolant Heater (ECH) high-voltage wire harness connectors to the high-voltage battery.
7. Remove the battery port cover, connect and lock the Power Inverter Module (PIM) high-voltage wire harness connector to the high-voltage battery.
8. Engage the two wire harness retainers to the high-voltage battery.
9. Install the coolant inlet (1) and outlet (2) hoses to the high-voltage battery and engage the quick-disconnects.
10. If required: Remove the hose-pinching pliers from the coolant inlet and outlet hoses.
11. Install the rear suspension belly pan, battery belly pan, charger belly pan and engine belly pan.

SAFETY RECALL

NORTH AMERICA

Plug-in Hybrid Electric Vehicle Fires



Reference: 73B / NHTSA 24V-536

FCA US LLC

12. Remove the support and lower the vehicle.

CAUTION: Only deionized or distilled water can be used in the PHEV cooling systems. The use of tap water is prohibited as this can damage the components.

NOTE: A 50/50 mixture of an ethylene glycol based antifreeze formulated with Organic Additive Technology (OAT) and deionized or distilled water is required, such as MOPAR 68163849AB 50/50 Prediluted Antifreeze/Coolant.

13. **The preferred method to remove air and fill the cooling system is to perform the Coolant Air Evacuation procedure using the Mopar Essential Tools and Service Equipment [Tool, UView Airlift™ Cooling System Refill 399-550000](#) or equivalent.**

14. Remove the filler cap from the coolant reservoir.

15. **If cooling system evacuation and purging equipment is not available:**

- Slowly add the engine coolant through the filler neck until the coolant level reaches the MAX level of the coolant reservoir.
- Attach the SVT275 Cooling Pressure Tester (2), available from Mopar® Service Equipment, or an equivalent to the pressurized coolant bottle (1).
- Operate tester pump to apply 100 kPa (15 psig) pressure to system. This should force coolant into any voids created by trapped air.
- Release pump pressure and remove tester.
- Add engine coolant until the coolant level again reaches the MAX level of the coolant reservoir.
- Repeat this process until the coolant level stabilizes at the MAX level of the coolant reservoir.

SAFETY RECALL

NORTH AMERICA

Plug-in Hybrid Electric Vehicle Fires



Reference: 73B / NHTSA 24V-536

FCA US LLC

16. Position the white sleeve in the full upright position for installation of the MSD to verify proper engagement as shown (Figure 21).



Figure 21 – MSD Position

NOTE: If necessary, use a small screwdriver to loosen and guide the white sleeve to the full upward position as shown (Figure 22).



Figure 22 – White Sleeve

SAFETY RECALL

NORTH AMERICA

Plug-in Hybrid Electric Vehicle Fires



Reference: 73B / NHTSA 24V-536

FCA US LLC

17. Ensure that the mounting interface surface of the high-voltage Manual Service Disconnect (MSD) and the receptacle wall is clean, and that there are no surface contaminants or foreign objects within the receptacle.
18. Align the polarization feature (1) of the high-voltage MSD with the receptacle on the high-voltage battery (Figure 23).
19. Push the high-voltage MSD evenly into the receptacle with the lever (1) in the 90° position.

NOTE: With the high-voltage MSD properly aligned with the receptacle, the lever (1) will be released and allowed to rotate to the lock position (Figure 24).

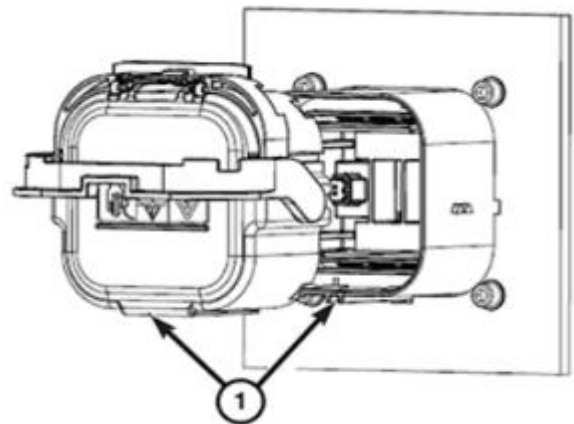

Figure 23 – MSD Installation

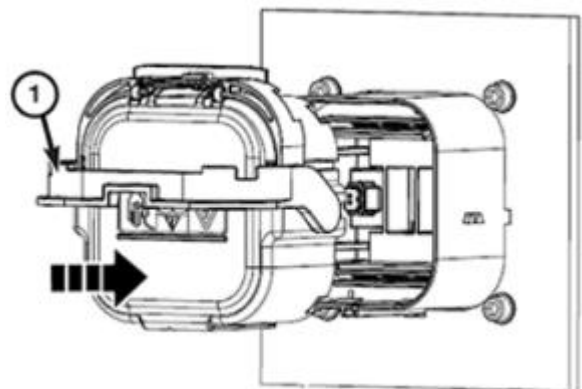

Figure 24 – MSD Lever

SAFETY RECALL

NORTH AMERICA

Plug-in Hybrid Electric Vehicle Fires



Reference: 73B / NHTSA 24V-536

FCA US LLC

20. Rotate the lever (1) while maintaining a slight force on the high-voltage MSD. The lever will engage the receptacle and draw the high-voltage MSD down onto the receptacle as the lever is rotated.

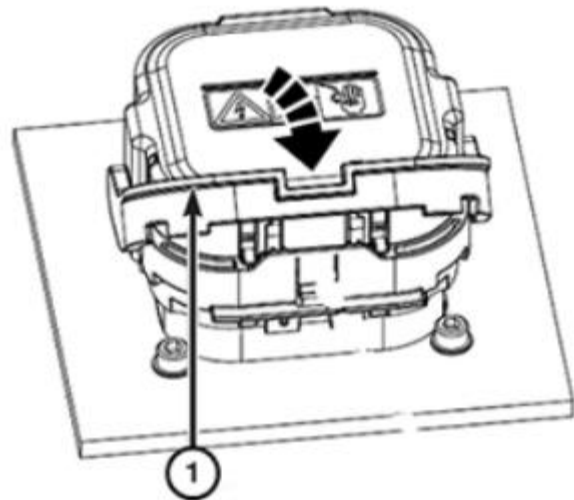

Figure 25 – MSD Lever Locking

21. Rotate the lever (1) downward until it is fully engaged and locked by the lever release latch (2). An audible “click” will be heard as the lever latches into position. Gently pull the high-voltage MSD upward to ensure that it is fully seated in the receptacle and locked. If the MSD is able to be removed, repeat steps 16 – 21 (Figure 25).

22. Install the high-voltage MSD floor access cover and tighten the four screws to 2.5 N·m (22In. lbs.).

NOTE: The clearance between the top of the high-voltage MSD and the bottom of the access cover is such that the access cover cannot be installed if the high-voltage MSD is not fully seated.

23. Install the rear carpet.
24. Connect the B+ battery cable to the 12-volt Power Distribution Center (PDC) and tighten the terminal nut to 9 N·m (80In. lbs.).
25. Install the air cleaner body.

SAFETY RECALL

NORTH AMERICA

Plug-in Hybrid Electric Vehicle Fires



Reference: 73B / NHTSA 24V-536

FCA US LLC

26. Close the hood, insert the key in the ignition, press the START button and verify that the Hybrid Status Indicator is green and no warnings are displayed.
27. Connect the WiTECH tool to the vehicle diagnostic connector and perform the “Replace BPCM” procedure in the BPCM section of the scan tool.

NOTE: If this procedure is not run the vehicle will not start. The high voltage battery pack is shipped with the contactors locked in the open position for safety concerns. Until this routine is run the battery pack contactors will not close resulting in a no start condition.

28. **The new high-voltage battery pack must be flash programmed to operate.**
29. **With the scan tool, flash program the Battery Pack Control Module (BPCM) with the latest software.**
30. Return the vehicle to the customer.

This notice applies to your vehicle,

[Model Year and Model]

VIN XXXXXXXXXXXXXXXXXXXX

73B/NHTSA 24V-536

LOGO

VEHICLE PICTURE

YOUR SCHEDULING OPTIONS

1. RECOMMENDED OPTION

Call your authorized Chrysler / Dodge / Jeep® / RAM Dealership.

2. Call the FCA Recall Assistance Center at 1-800-853-1403. An agent can confirm part availability and help schedule an appointment.

3. Visit recalls.mopar.com, scan the QR code below, or download the Mopar Owner's Companion App.

QR Code

Get access to recall notifications, locate your nearest dealer, and more through this website or Mopar Owner's Companion App. You will be asked to provide your Vehicle Identification Number (VIN) to protect and verify your identity. The last eight characters of your VIN are provided above.

DEALERSHIP INSTRUCTIONS

Please reference Safety Recall 73B.

IMPORTANT SAFETY RECALL

Plug-in Hybrid Electric Vehicle Fires

Dear [Name],

This notice is sent to you in accordance with the National Traffic and Motor Vehicle Safety Act.

FCA US LLC has decided that a defect, which relates to motor vehicle safety, exists in certain [2017 - 2018 model year (RU) Chrysler Pacifica] Plug-In Hybrid Electric Vehicles (PHEV)s.

It is extremely important to take steps now to repair your vehicle to ensure the safety of you and your passengers.

WHY DOES MY VEHICLE NEED REPAIRS?

Your vehicle ^[1] may still be at risk of experiencing a fire originating from the high voltage (HV) battery even after having the remedy for FCA US Recall ID Z11 (NHTSA Recall ID 22V-077) completed. A folded or torn anode tab may result in the generation of lithium by-product over time. This defect, along with a second unidentified factor, may lead to an internal short within the pack and may result in a vehicle fire. **A vehicle fire may increase the risk of injury to occupants and persons outside of the vehicle, as well as property damage.**

Until further notice, FCA is advising owners of these hybrid vehicles to refrain from recharging the high voltage battery, and to park them away from structures and other vehicles.

HOW DO I RESOLVE THIS IMPORTANT SAFETY ISSUE?

FCA US LLC will repair your vehicle ^[2] free of charge (parts and labor). To do this, your dealer will update the HV Battery Pack Control Module (BPCM) with revised software to monitor battery pack assembly operational status for conditions that could lead to a fire in the battery pack assembly. Your dealer will also inspect and, if necessary, replace the battery pack assembly. The estimated repair time is **1.5 to 2 days**. While your vehicle is serviced FCA US will provide you a rental vehicle or courtesy transportation free of charge. In addition, your dealer will require your vehicle for proper check-in, preparation, and check-out during your visit, which may require more time. Your time is important to us, so we recommend that you schedule a service appointment to minimize your inconvenience. Ask your dealer for alternate transportation options while your vehicle is in service. Please bring this letter with you to your dealership.

**TO SCHEDULE YOUR FREE REPAIR,
CALL YOUR CHRYSLER, DODGE, JEEP OR RAM DEALER TODAY**

WHAT IF I ALREADY PAID TO HAVE THIS REPAIR COMPLETED?

If you have already experienced this specific condition and have paid to have it repaired, you may visit www.fcarecallreimbursement.com to submit your reimbursement request online. ^[3] Once we receive and verify the required documents, reimbursement will be sent to you within 60 days. If you have had previous repairs performed and/or already received reimbursement, you may still need to have the recall repair performed.

We apologize for any inconvenience, but are sincerely concerned about your safety. Thank you for your attention to this important matter.

Customer Assistance/Field Operations
FCA US LLC



Mr. Mrs. Customer
1234 Main Street
Hometown, MI 48371

[1] If you no longer own this vehicle, please help us update our records. Call the FCA Recall Assistance Center at 1-800-853-1403 to update your information.

[2] If your dealer fails or is unable to remedy this defect without charge and within a reasonable time, you may submit a written complaint to the Administrator, National Highway Traffic Safety Administration, 1200 New Jersey Ave., S.E., Washington, DC 20590, or you can call the toll-free Vehicle Safety Hotline at 1-888-327-4236 (TTY 1-800-424-9153), or go to safercar.gov.

[3] You can also mail in your original receipts and proof of payment to the following address for reimbursement consideration: FCA Customer Assistance, P.O. Box 21-8004, Auburn Hills, MI 48321-8007, Attention: Recall Reimbursement.

Note to lessors receiving this recall notice: Federal regulation requires that you forward this recall notice to the lessee within 10 days.