



IMPORTANT INFORMATION FOR RECALL WARRANTY REIMBURSEMENT

NHTSA Recall No. **24V-501**

July 24, 2023

Please follow the instructions listed below for reimbursement for this Recall. E-ONE must supply the following information to Reyco Granning for reimbursement.

- 1) Take a picture of the bolt heads **BEFORE** removing them.
- 2) Take a picture of the serial number tag on the axle. NOTE: If it is painted over, please remove the paint, if necessary, so that the axle serial number is legible.
- 3) Follow the instructions in the included Reyco Granning Campaign Service Bulletin LCAB 0524, Document D716778.
- 4) Take a picture of the bolt heads **AFTER** installing them.
- 5) Please include the following:
 - a) A copy of the Service Order
 - b) The truck VIN
 - c) The In-Service Date
 - d) The Repair Date
 - e) The vehicle mileage
- 6) Please email all photos and information to E-ONE to the following email:
lstephens@revgroup.com

We apologize for any inconvenience this Safety Recall may cause, your safety is our first concern.

Sincerely,

Leroy Stephens

Engineer IV

E-ONE, Inc.

lstephens@revgroup.com



Campaign Service Bulletin LCAB 0524

Document D716778

Date: 05/08/2024

REV: OR

Subject: Inboard Lower Control Arm (LCA) Bolts

Condition: Some units were produced with defective bolts.

Applies To: **Fire Truck** IFS 20k, 22k and 24k Models

Reyco Mfg Date Range: **04/19/2023 to 04/23/2024**

Vocation: Fire Apparatus

Purpose: To provide instructions for inspection repair of the effected joints.

Please Read the Entire Tech Tip Before Proceeding With Any Work. Follow industry standards regarding safety equipment and procedures.

Inspection and Repair should be conducted immediately.

Tools Needed:

1. 1-5/16 inch combination wrench
2. ¾ inch drive impact
3. 1-5/16 inch, ¾ drive impact socket.
4. Two eccentric wrenches or two 2 inch 12 point box end wrenches
5. Torque wrench, ¾ drive, capable of 475 ft/lbs.
6. Bottle jacks.

Parts: Kit #K716778 that includes the following:

- (4) 710244-01 Bolts
- (4) 710245-01 Lock nuts
- (8) 104098 Washers
- (1) D716778 Installation Instruction

Replacement:

1. Using industry standard equipment, safely lift and support the truck frame per chassis builder direction, just high enough to exhaust the air springs. Lifting the truck too much will make the job more difficult.

2. **Mark the orientation of all 8 alignment eccentrics, shown below.**

MARK POSITION OF ALL ECCENTRICS
IN LINE WITH SET SCREW WITH PAINT
PEN OR SIMILAR BEFORE LOOSENING JOINTS

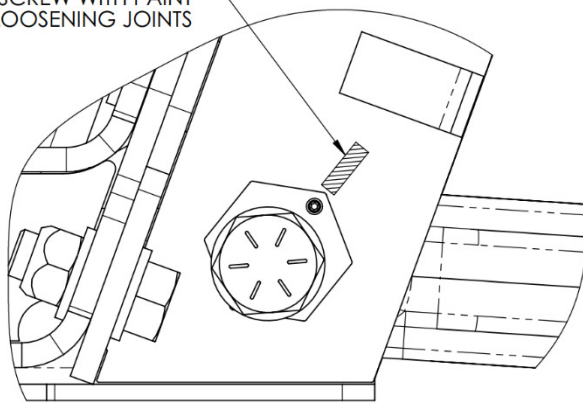

3. Loosen all the lower control arm bolts just enough that the eccentrics can be adjusted if necessary. Note; the next step will be easier if all the eccentrics are returned to the neutral (12 O'clock position). Also a pry bar placed under the control arm can help with lining up the holes for bolt installation.

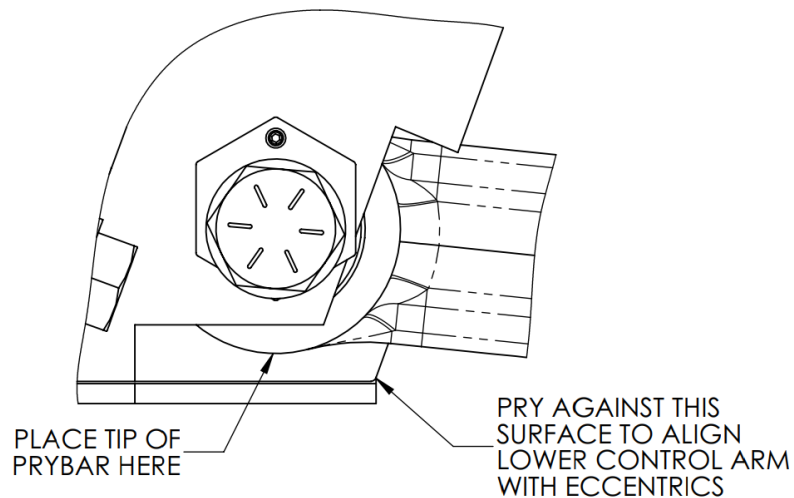



Campaign Service Bulletin LCAB 0524

Document D716778

Date: 05/08/2024

REV: OR

4. One at a time remove and discard the original LCA bolt, nut and washers and replace with the new bolt, nut and washers provided. Ensure that the washers within the cradle pocket are in place with the bolt capturing them.
 - a. Make sure both eccentrics engage the cradle and snug up the bolt enough to keep the eccentrics engaged with the cradle.
5. **Once all 4 bolts have been replaced, rotate the eccentrics to the position previously marked. Position the suspension at ride height.**
6. Torque all 4 bolts to 475 ft/lbs. applied to the bolt head.

Note: Provided all eccentrics are positioned as originally found no alignment will be required. Alignment expense will not be covered.

Approved labor is 2 hours at \$125.00

All claims must include a copy of the service order, the truck VIN, the IFS serial number, In Service Date, repair date and mileage.