



I N F I N I T I

VOLUNTARY RECALL CAMPAIGN

Classification: PD24-001	Reference: ITB24-007	Date: June 24, 2024
-----------------------------	-------------------------	------------------------

VOLUNTARY SAFETY RECALL CAMPAIGN REAR PROPELLER SHAFT REPLACEMENT

CAMPAIGN ID #: R24A5 and R24A7
APPLIED VEHICLES: 2012-2013 M35 Hybrid (HY51)
2011-2013 M56 (Y51)
2014-2018 Q50 Hybrid (HV37)
2014-2019 Q70 (Y51)
2015-2019 Q70L (Y51)
2014-2018 Q70 Hybrid (HY51)

APPLIED DRIVETRAIN: Rear Wheel Drive (RWD) only

**Check Service COMM or Dealer Business Systems (DBS)
National Service History to confirm campaign eligibility.**

INTRODUCTION

Infiniti is conducting this voluntary safety recall campaign on certain specific model year 2012-2013 M35 Hybrid, 2011-2013 M56, 2014-2018 Q50 Hybrid, 2014-2019 Q70, 2015-2019 Q70L, and 2014-2018 Q70 Hybrid vehicles to replace the rear propeller shaft. This service will be performed at no charge to the client for parts or labor.

IDENTIFICATION NUMBER

Infiniti has assigned identification numbers R24A5 and R24A7 to these campaigns. These numbers must appear on all communication and documentation of any nature dealing with this campaign.

RETAILER RESPONSIBILITY

It is the retailer’s responsibility to check Service COMM or Dealer Business Systems (DBS) National Service History for the campaign status on each vehicle falling within the range of this voluntary safety recall which for any reason enters the service department. This includes vehicles purchased from private parties or presented by transient (tourist) clients and vehicles in a retailer’s inventory. **Federal law requires that new vehicles in retailer inventory which are the subject of a safety recall must be corrected prior to sale. Failure to do so can result in civil penalties by the National Highway Traffic Safety Administration.** While federal law applies only to new vehicles, Infiniti strongly encourages retailers to correct any used vehicles in their inventory before they are retailed.

Bulletins are intended for use by qualified technicians, not 'do-it-yourselfers'. Qualified technicians are properly trained individuals who have the equipment, tools, safety instruction, and know-how to do a job properly and safely. **NOTE:** If you believe that a described condition may apply to a particular vehicle, DO NOT assume that it does. See your Infiniti retailer to determine if this applies to your vehicle.

SERVICE PROCEDURE

1. Replace the rear propeller shaft.
 - Refer to the ESM: **TRANSMISSION DRIVELINE > DRIVELINE > REAR PROPELLER SHAFT: 3S80A-R > REMOVAL AND INSTALLATION > REAR PROPELLER SHAFT > Removal and Installation**

IMPORTANT: Do not re-use the one-time use bolts, washers, or nuts.

- Center bearing mounting bracket nut torque: 45 N•m (4.6 kg-m, **33 ft-lb**)
- Rear propeller shaft nut torque: 73.5 N•m (7.5 kg-m, **55 ft-lb**)

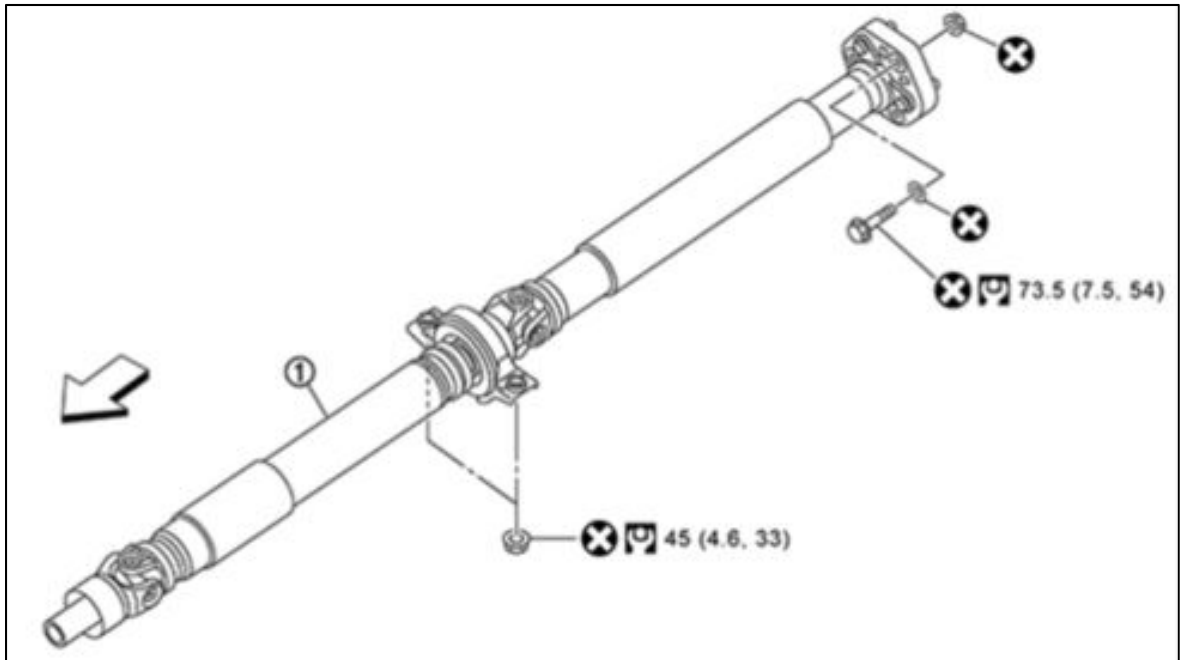

Figure 1

PARTS INFORMATION

DESCRIPTION	MODEL	PART NUMBER	QUANTITY
PROPELLER SHAFT	Q50 Hybrid	C7000-4GA0B	1
	M35 Hybrid	C7000-1MG0C	
	Q70 Hybrid	C7000-3WG0C	
	M56, Q70	C7000-1MC1C	
	Q70L	C7000-6AE0C	
PROPELLER SHAFT BOLT KIT	ALL	C7120-AH00A	1
GASKET – EXHAUST	ALL	20692-8H30A	1
	M35 Hybrid, M56, Q70, Q70L	20691-30P0A	1
	M35 Hybrid, M56, Q70, Q70L	20692-JK00B	2
	Q50 Hybrid	20692-JK00B	4
NUT – FLANGE, HEX	ALL	08918-3401A	6
NUT – FIX, EXHAUST TUBE	ALL	20602-41G0A	4

CLAIMS INFORMATION

Submit a “CM” line claim using the following claims coding:

CAMPAIGN (“CM”) ID	MODEL	DESCRIPTION	OP CODE	FRT
R24A5	M35 Hybrid, M56, Q70, Q70L, Q70 Hybrid	Replace Rear Propeller Shaft	R24A50	1.0
R24A7	Q50 Hybrid	Replace Rear Propeller Shaft	R24A70	0.8

AMENDMENT HISTORY

PUBLISHED DATE	REFERENCE	DESCRIPTION
June 24, 2024	ITB24-007	Original bulletin published