

Safety Recall

Code: 69PZ

Subject Passenger Occupant Detection System (PODS)

Document History

Date	Summary
09/26/2024	Original publication

Affected Vehicles

Country	Beginning Model Year	Ending Model Year	Vehicle	Vehicle Count
USA	2021	2024	ATLAS	171,086
USA	2020	2024	ATLAS CROSS SPORT	100,227
CAN	2021	2024	ATLAS	24,097
CAN	2020	2024	ATLAS CROSS SPORT	11,651

Check Campaigns/Actions screen in ELSA on the day of repair to verify that a VIN qualifies for repair under this action. ELSA is the only valid campaign inquiry & verification source.

- ✓ Campaign status must show "open."
- ✓ If ELSA shows other open action(s), inform your customer so that the work can also be completed at the same time the vehicle is in the workshop for this campaign.

Wave Rollout

The 69PZ is being rolled out in waves, based on availability of parts as follows:

WAVE	CRITERIA	WAVE TOTAL COUNT	REPAIR AVAILABLE
1	D1, E1, N1, P1, D3, N3	USA = 55,098 CAN = 31,609	YES
2	A1, B1, K1, L1	USA = 4,562 CAN = 576	NO
3	C1, C2, M1, M2	USA = 211,653 CAN = 3,563	NO

Problem Description

A wire with a contact fault may cause the Passenger Occupant Detection System (PODS) to detect a malfunction and switch off the passenger airbag, even though the seat may be occupied. In a crash with frontal airbag deployment, there would be an increased risk of injury to the occupant seated in the front passenger seat if the passenger frontal airbag is switched off or not working.

Corrective Action

Replace the PODS sensor mat and wiring harness.

Precautions

Should a malfunction occur, vehicle occupants will be alerted by illumination of the airbag warning light, an acoustic warning sound, an error message displayed in the instrument cluster and by the status of the Passenger Airbag OFF indicator light. If this happens, owners are advised to make an appointment with an authorized Volkswagen dealer to have the vehicle inspected without delay.

As a reminder, the vehicle owner's manual contains important information regarding vehicle warning lights and messages. We encourage anyone who drives the vehicle to review the owner's manual to become familiar with the types of vehicle indicators, warnings and messaging they may see.

Volkswagen advises owners to follow all cautions and warnings described in the owner's manual regarding the Passenger Occupant Detection System (PODS).

Do not use the passenger seat if a PODS error message displays on the instrument panel or if the airbag indicator light displays "passenger airbag off" with an occupant in the seat.

Code Visibility	On June 25, 2024, the campaign code was applied to affected vehicles.
Owner Notification	Owner notification will take place in waves, starting in September 2024. Owner letter examples are included in this bulletin for your reference.
Additional Information	<p>Please alert everyone in your dealership about this action, including Sales, Service, Parts and Accounting personnel. Contact Warranty if you have any questions.</p> <p>IMPORTANT REMINDER ON VEHICLES AFFECTED BY SAFETY & COMPLIANCE RECALL:</p> <p><u>New Vehicles in Dealer Inventory:</u> It is a violation of federal law for a dealer to deliver a new motor vehicle or any new or used item of motor vehicle equipment (including a tire) covered by this notification under a sale or lease until the defect or noncompliance is remedied. By law, dealers must correct, prior to delivery for sale or lease, any vehicle that fails to comply with an applicable Federal Motor Vehicle Safety Standard or that contains a defect relating to motor vehicle safety.</p> <p><u>Pre-Owned Vehicles in Dealer Inventory:</u> Dealers should not deliver any pre-owned vehicles in their inventory which are involved in a safety or compliance recall until the defect has been remedied.</p> <p>Dealers must ensure that every affected inventory vehicle has this campaign completed <u>before delivery to consumers.</u></p> <p>Fill out and affix Campaign Completion Label (CAMP 010 000) after work is complete. <i>Labels can be ordered at no cost via the Compliance Label Ordering portal at www.vwhub.com.</i></p>

Parts Information

NOTE

The 69PZ is being rolled out in waves, based on availability of parts. If a VINs criteria is not listed, the repair is not yet available.

Criteria	Quantity	Part Number	P.O.C. Part Description	Ordering Method
D1	1	3CN-963-556-J	HTR ELEMNT	Reference POC comments individually by part number.
	1	3CN-971-392-L	HARNESS	
	As needed	N -015-261-2	CLAMP	
	2	N -106-622-01	TIE WRAP	
E1	1	3CN-963-556-J	HTR ELEMNT	Reference POC comments individually by part number.
	1	3CN-971-392-K	HARNESS	
	As needed	N -015-261-2	CLAMP	
	2	N -106-622-01	TIE WRAP	
N1	1	3CN-963-556-J	HTR ELEMNT	Reference POC comments individually by part number.
	1	3CM-971-392-L	HARNESS	
	As needed	N -108-676-01	CLAMP	
	2	N -106-622-01	TIE WRAP	
P1	1	3CN-963-556-J	HTR ELEMNT	Reference POC comments individually by part number.
	1	3CM-971-392-K	HARNESS	
	As needed	N -108-676-01	CLAMP	
	2	N -106-622-01	TIE WRAP	
D3	1	3CN-963-556-J	HTR ELEMNT	Reference POC comments individually by part number.
	1	3CN-971-472-E	HARNESS	
	As needed	N -108-676-01	CLAMP	
	2	N -106-622-01	TIE WRAP	
N3	1	3CN-963-556-J	HTR ELEMNT	Reference POC comments individually by part number.
	1	3CN-971-472-E	HARNESS	
	As needed	N -108-676-01	CLAMP	
	2	N -106-622-01	TIE WRAP	

Continued on next page

Initial Allocation: Part # 3CN-971-472-E YES	Dealers will be sent a small initial allocation prior to customer notification. If no initial allocation was received, please reference your dealer's Estimated Remaining Repairs by campaign to view your potential VIN population.
--	--

Initial Allocation: All other part numbers NO	There will be no parts allocation.
---	------------------------------------

 NOTE	
Your dealer's Estimated Remaining Repairs by campaign can be found in Parts on Command. Click on "View Campaign List" and review the Estimated Remaining Repairs column.	

 NOTE	
Campaign parts should always be ordered as per the parts information in this circular. The ordering system will supersede the part, if applicable.	

Claim Entry Instructions

The labor times listed here may differ from the labor operations and labor times listed in ELSA.

After campaign has been completed, enter claim as soon as possible to help prevent work from being duplicated elsewhere. Attach the ELSA screen print showing action open on the day of repair to the repair order.

If a customer declines campaign work, refer to the "Customer Declines Campaign/Update Repair" section in the Campaign/Update Policy and Procedures Manual.

Service Number	69PZ		
Damage Code	0099		
Parts Vendor Code	WWO		
Claim Type	Sold vehicle: 7 10 Unsold vehicle: 7 90		
Causal Indicator	Mark HTR ELEMNT* as causal part		
Vehicle Wash/Loaner	Do not claim wash/loaner under this action. Loaner/rental coverage cannot be claimed under this action. However, loaner/rental may be covered under the current loaner/mobility program. Please refer to the Volkswagen Warranty Policy and Procedures Manual for loaner claims information and reimbursement details.		
NOTE			
The 69PZ is being rolled out in waves, based on availability of parts. If a VINs criteria is not listed, the repair is not yet available.			
Criteria I.D.	All criteria with repair available		
	Replace PODS sensor mat (seat heating element) and wiring harness		
	LABOR		
	Labor Op	Time Units	Description
	6956 55 99	150	Replace PODS sensor mat (seat heating element) and wiring harness
	0150 00 10	SEE ELSA	GFF/Guided functions (<i>setup + battery charger</i>)
	0150 00 60	Time stated on diagnostic protocol	GFF/Guided functions (<i>perform basic settings</i>)

Continued on next page

Criteria I.D.	D1		
	PARTS		
	Quantity	Part Number	Description
	1.00	3CN963556J	HTR ELEMNT*
	1.00	3CN971392L	HARNESS
	Up to 20.00	N 0152612	CLAMP
2.00	N 10662201	TIE WRAP	

Criteria I.D.	E1		
	PARTS		
	Quantity	Part Number	Description
	1.00	3CN963556J	HTR ELEMNT*
	1.00	3CN971392K	HARNESS
	Up to 20.00	N 0152612	CLAMP
2.00	N 10662201	TIE WRAP	

Criteria I.D.	N1		
	PARTS		
	Quantity	Part Number	Description
	1.00	3CN963556J	HTR ELEMNT*
	1.00	3CM971392L	HARNESS
	Up to 20.00	N 10867601	CLAMP
2.00	N 10662201	TIE WRAP	

Criteria I.D.	P1		
	PARTS		
	Quantity	Part Number	Description
	1.00	3CN963556J	HTR ELEMNT*
	1.00	3CM971392K	HARNESS
	Up to 20.00	N 10867601	CLAMP
2.00	N 10662201	TIE WRAP	

Continued on next page

Criteria I.D.	D3		
	PARTS		
	Quantity	Part Number	Description
	1.00	3CN963556J	HTR ELEMNT*
	1.00	3CN971472E	HARNESS
	Up to 20.00	N 10867601	CLAMP
	2.00	N 10662201	TIE WRAP

Criteria I.D.	N3		
	PARTS		
	Quantity	Part Number	Description
	1.00	3CN963556J	HTR ELEMNT*
	1.00	3CN971472E	HARNESS
	Up to 20.00	N 10867601	CLAMP
	2.00	N 10662201	TIE WRAP

Customer Letter Example (USA)

<MONTH YEAR>

<CUSTOMER NAME>

<CUSTOMER ADDRESS>

<CUSTOMER CITY STATE ZIPCODE>

This notice applies to your vehicle: <MODEL YEAR> <BRAND> <CARLINE>, <VIN>

NHTSA: 24V464

Subject: Safety Recall 69PZ – Passenger Occupant Detection System (PODS)

Dear Volkswagen Owner,

This notice is sent to you in accordance with the National Traffic and Motor Vehicle Safety Act. Volkswagen has decided that a defect, which relates to motor vehicle safety, exists in certain 2020-2024 model year Volkswagen vehicles. Our records show that you are the owner of a vehicle affected by this action.

What is the issue?

A wire with a contact fault may cause the Passenger Occupant Detection System (PODS) to detect a malfunction and switch off the passenger airbag, even though the seat may be occupied. In a crash with frontal airbag deployment, there would be an increased risk of injury to the occupant seated in the front passenger seat if the passenger frontal airbag is switched off or not working.

What will we do?

To correct this defect, your authorized Volkswagen dealer will replace the PODS sensor mat and wiring harness. This work will take about three hours to complete and will be performed for you free of charge. Please keep in mind that your dealer may need additional time for the preparation of the work, as well as to accommodate their daily workshop schedule.

What should you do?

Please contact your authorized Volkswagen dealer without delay to schedule this recall work. To set up an appointment online, please visit www.vw.com/find-a-dealer.

Precautions you should take:

Should a malfunction occur, vehicle occupants will be alerted by illumination of the airbag warning light, an acoustic warning sound, an error message displayed in the instrument cluster and by the status of the Passenger Airbag OFF indicator light. If this happens, owners are advised to make an appointment with an authorized Volkswagen dealer to have the vehicle inspected without delay.

As a reminder, your vehicle owner's manual contains important information regarding your vehicle's warning lights and messages. We encourage you and anyone who drives your vehicle to review the owner's manual to become familiar with the types of vehicle indicators, warnings and messaging you may see.

Volkswagen advises you to follow all cautions and warnings described in the owner's manual regarding the Passenger Occupant Detection System (PODS).

Do not use the passenger seat if a PODS error message displays on the instrument panel or if the airbag indicator light displays "passenger airbag off" with an occupant in the seat.

Additional Information

- If you are the lessor and registered owner of the vehicle identified in this action, the law requires you to forward this letter immediately via first-class mail to the lessee within ten (10) days of receipt.
- If your authorized Volkswagen dealer fails or is unable to complete this work free of charge within a reasonable time, if you have changed your address or sold the vehicle, or if you should have any questions about this communication, please reach out to us using your preferred method of communication at www.vw.com/contact or by calling us at 800-893-5298.
- If you still cannot obtain satisfaction, you may file a complaint with: The Administrator, National Highway Traffic Safety Administration, 1200 New Jersey Avenue, SE., Washington, DC 20590; or call the toll-free Vehicle Safety Hotline at 1-888-327-4236 (TTY: 1-800-424-9153); or go to <http://www.safercar.gov>.
- To check your vehicle's eligibility for repair under this or any other recall/service campaign, please visit www.vw.com/owners/recalls and enter your Vehicle Identification Number (VIN) into the Recall/Service Campaign Lookup tool.
- If you have previously paid for repairs relating to the condition described in this letter, the enclosed form explains how to request reimbursement. We would be pleased to review your reimbursement request.

We apologize for any inconvenience this matter may cause; however, we are taking this action to help ensure your safety and continued satisfaction with your vehicle.

Sincerely,

Volkswagen Customer Protection

Customer Letter Example (Canada)

<MONTH YEAR>

<CUSTOMER NAME>

<CUSTOMER ADDRESS>

<CUSTOMER CITY STATE ZIPCODE>

This notice applies to your vehicle: <MODEL YEAR> <BRAND> <CARLINE>, <VIN>

Transport Canada Recall: 2024-354

Subject: Safety Recall 69PZ – Passenger Occupant Detection System (PODS)

Dear Volkswagen Owner,

This notice is sent to you in accordance with the requirements of the *Motor Vehicle Safety Act*. This is to inform you that your vehicle may contain a defect that could affect the safety of a person. Our records show that you are the owner of a vehicle affected by this action.

What is the issue?

A wire with a contact fault may cause the Passenger Occupant Detection System (PODS) to detect a malfunction and switch off the passenger airbag, even though the seat may be occupied. In a crash with frontal airbag deployment, there would be an increased risk of injury to the occupant seated in the front passenger seat if the passenger frontal airbag is switched off or not working.

What will we do?

To correct this defect, your authorized Volkswagen dealer will replace the PODS sensor mat and wiring harness. This work will take about three hours to complete and will be performed for you free of charge. Please keep in mind that your dealer may need additional time for the preparation of the work, as well as to accommodate their daily workshop schedule.

What should you do?

Please contact your authorized Volkswagen dealer without delay to schedule this recall work.

Precautions you should take:

Should a malfunction occur, vehicle occupants will be alerted by illumination of the airbag warning light, an acoustic warning sound, an error message displayed in the instrument cluster and by the status of the Passenger Airbag OFF indicator light. If this happens, owners are advised to make an appointment with an authorized Volkswagen dealer to have the vehicle inspected without delay.

As a reminder, your vehicle owner's manual contains important information regarding your vehicle's warning lights and messages. We encourage you and anyone who drives your vehicle to review the owner's manual to become familiar with the types of vehicle indicators, warnings and messaging you may see.

Volkswagen advises you to follow all cautions and warnings described in the owner's manual regarding the Passenger Occupant Detection System (PODS).

Do not use the passenger seat if a PODS error message displays on the instrument panel or if the airbag indicator light displays "passenger airbag off" with an occupant in the seat.

Additional Information

- If you are the lessor and registered owner of the vehicle identified in this letter, you shall forward this letter (and any subsequent notice, if applicable) to the lessee within ten (10) days of receipt.
- If your authorized Volkswagen dealer fails or is unable to complete this work free of charge within a reasonable time, if you have changed your address or sold the vehicle, or if you should have any questions about this communication, please contact Customer Relations, Monday through Friday from 8AM to 8PM EST by phone at 1-800-822-8987 or via our "Contact Us" page at www.vw.ca.
- If you have previously paid for repairs relating to the condition described in this letter, the enclosed form explains how to request reimbursement. We would be pleased to review your reimbursement request.

We apologize for any inconvenience this matter may cause; however, we are taking this action to help ensure your safety and continued satisfaction with your vehicle.

Sincerely,

Volkswagen Customer Protection

Repair Overview

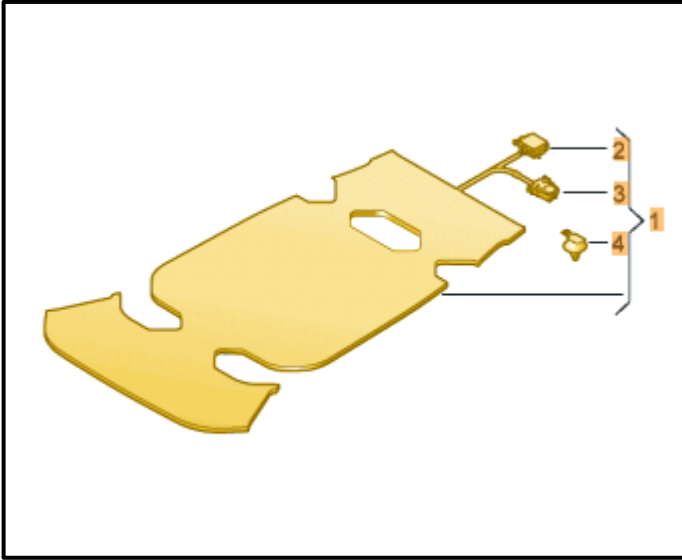

- Replace passenger occupancy detection sensor mat and seat harness.

NOTE

- These repair instructions may differ from the labor operations and labor times listed in ELSA.
- Damages resulting from improper repair or failure to follow these work instructions are the dealer's responsibility and are not eligible for reimbursement under this action.
- This procedure must be read in its entirety prior to performing the repair.
- Due to variations in vehicle equipment and options, the steps/illustrations in this work procedure may not identically match all affected vehicles.
- Diagnosis and repair of pre-existing conditions in the vehicle are not covered under this action.
- When working during extreme temperatures, it is recommended that the vehicle be allowed to acclimate inside the shop to avoid temperature-related component damage/breakage.

Required Tools

 <p>Battery Tester/Charger capable of minimum 70 Amp continuous supply</p>	 <p>Diagnostic Tester -VAS6150X/6160X- (or equivalent)</p>
 <p>Engine/Transmission Holder - Seat Repair Fixture -VAS6136-</p>	 <p>Engine and Transmission Holder -VAS6095A-</p>
 <p>Airbag Lockout Adapter -VAS6282-</p>	 <p>Trim Removal Wedge -3409- (or equivalent)</p>
 <p>T-Handle Hook -3438-</p>	 <p>Upholstery Clip Pliers -VAG1634B- (or equivalent)</p>

Repair Instruction

Section A - Check for Previous Repair

TIP

If Campaign Completion label is present, no further work is required.

Applicable criteria ID(s)	Campaign/Action Status
01 	Open 

EXAMPLE

Campaign/Action	Start	Designation
	2015-11-10	W-SERV_ACT -
	2018-12-13	RECALL -
	2017-05-16	A-RECALL -

EXAMPLE

- Enter the VIN in Elsa and proceed to the “Campaign/Action” screen.

TIP

On the date of repair, print this screen and keep a copy with the repair order.

- Confirm the Campaign/Action is open <arrow 1>. If the status is closed, no further work is required.
- Note the Applicable Criteria ID <arrow 2> for use in determining the correct work to be done and corresponding parts associated.

CRITICAL REPAIR STEP



All campaigns/actions with a repair available must be performed in order of the Start date <arrow 3>. The oldest should be performed first (unless otherwise noted in the repair instructions).

Proceed to section B

Section B – Repair Procedure

⚠ WARNING

Risk of injury. Refer to “Warning and Safety Precautions”, found in **Appendix A** at the end of this document.

ⓘ NOTE

If the following fault is present, complete this repair before performing further diagnosis:

- **B1225F1:** Seat occupied recognition sensor mat Shield wire, open circuit.

ⓘ NOTE

If fault **B121400:** “Passenger occupant detection function restriction due to environmental influences” is present and/or staining is found on the seat cover and/or seat cushion during the repair:

- Replacement of components damaged by outside influences are not covered under this campaign.

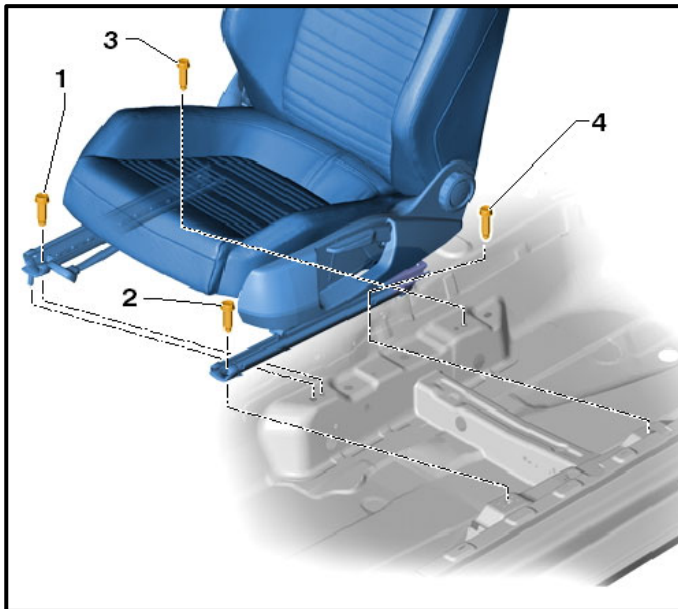

Unbolt passenger front seat:

- Move the seat as far forward as possible.
- Remove the bolts <3> and <4>.
- Move the seat as far back as possible.
- Remove the bolts <1> and <2>.
- Move seat to its highest position (if adjustable).
- Position the seat to where all four bolt holes are accessible.

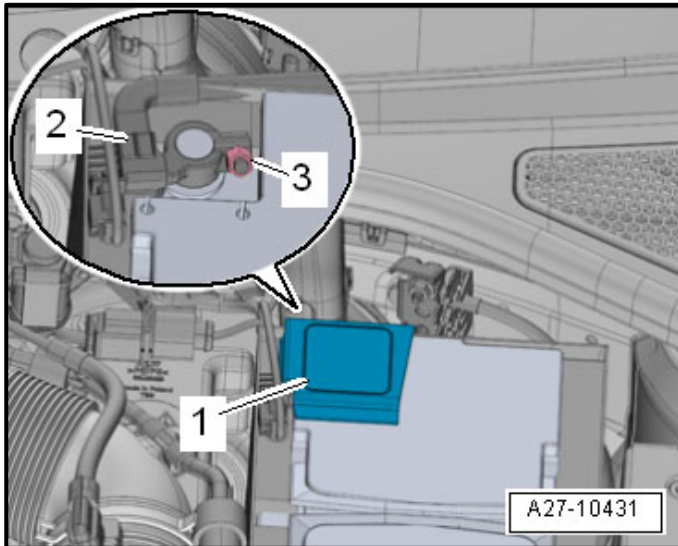

Disconnect the battery:

- Turn off the ignition and all electrical equipment.
- Move the ignition key outside of the vehicle to prevent the ignition from switching on unintentionally.
- Open the cover <1> over the battery ground terminal post.
- Loosen the nut <3> several turns.
- Remove the battery ground cable terminal clamp <2> from the battery and isolate the terminal.



Disconnect connectors:

⚠ WARNING

Before handling pyrotechnic components (for example, disconnecting the connector), the person handling it must “discharge static electricity”. This can be done by touching the door striker, for example.

⚠ WARNING

Follow the general safety precautions when working with airbags, belt tensioners and battery cut-out units (pyrotechnic components).

- Tilt the seat <1> towards the rear of the vehicle <arrow> to access the seat harness connections.

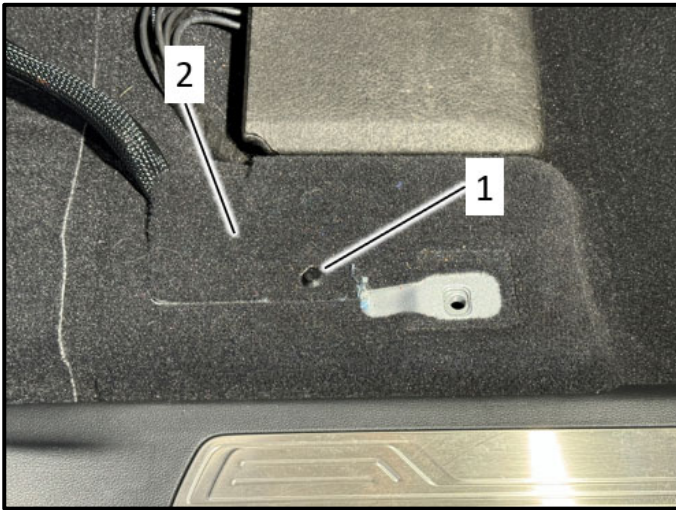

- Remove the expanding rivet <1>.
- Open the carpet cover <2>.

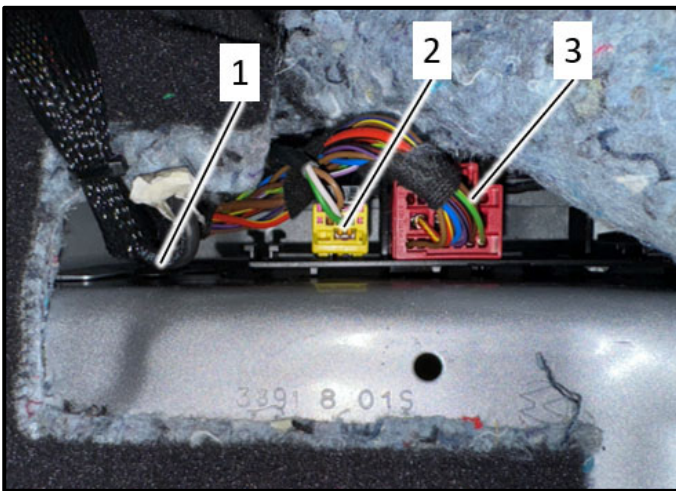

- Release the harness clip <1> from the body.
- Disconnect the connectors <2> and <3>.
- Connect the airbag adapter -VAS6282- to connector <2>.



Remove passenger front seat:

CAUTION

Risk of consequential damage!

- When removing the seat from the vehicle, it must not be grasped by the attachments. For example, do not lift seat by the seat belt latch, lever for seat forward/back adjustment, lever for seat height adjustment, seat trim panels or damage may result.
- Protect the seat attachments and vehicle interior from damage using suitable materials.

- Remove the seat <1> from the vehicle.

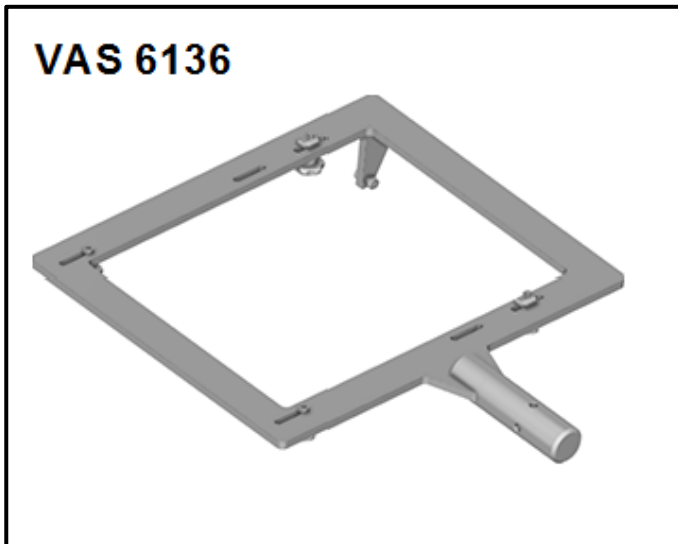

Attach seat to -VAS6136-:

- Attach the Seat Repair Fixture -VAS6136- to the Engine and Transmission Holder -VAS6095-.
- Fasten the front seat onto the Seat Repair Fixture -VAS6136-.

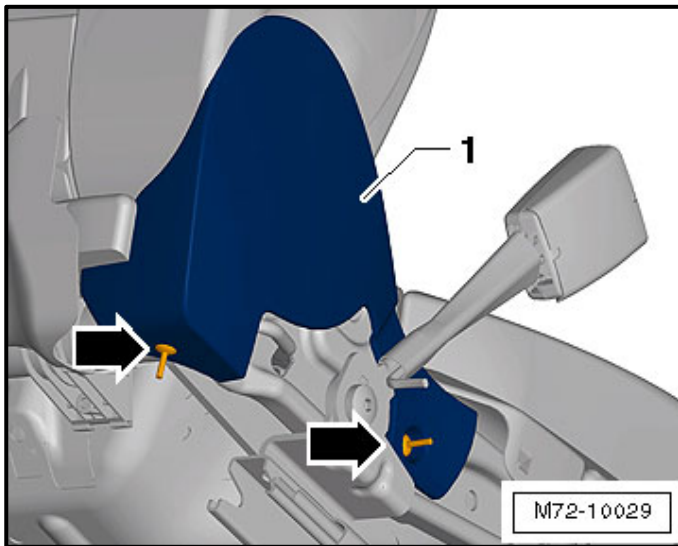

Remove tunnel side seat trim:

- Remove the trim panel <1> expanding rivets <arrows>.
- Pry out the expanding rivets <arrows> using the Trim Removal Wedge -3409-.
- Remove the trim panel <1> from the seat frame.

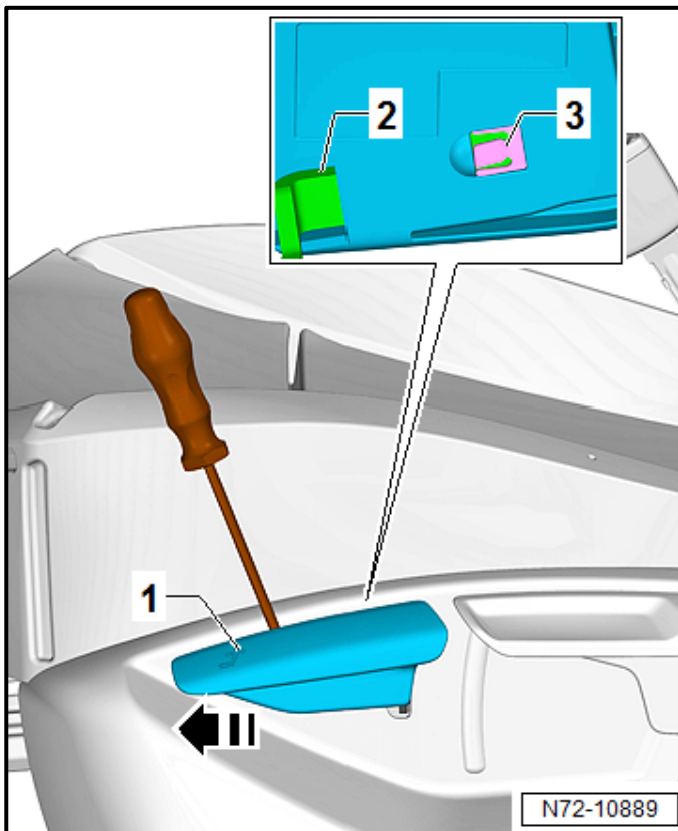

Remove backrest and height adjustment handles (Depending on equipment):

- Pull the backrest adjustment handle <1> as far upward as possible and hold it in that position.
- Guide a small screwdriver up to the retainer <3> between the backrest adjustment handle <1> and the trim.
- Press the retaining tab <3> inward using the screwdriver.
- At the same time, remove the backrest adjustment handle <1> from the lever <2> in the direction indicated <arrow>.
- Remove the seat height adjustment handle (if equipped) in the same manner as listed above.

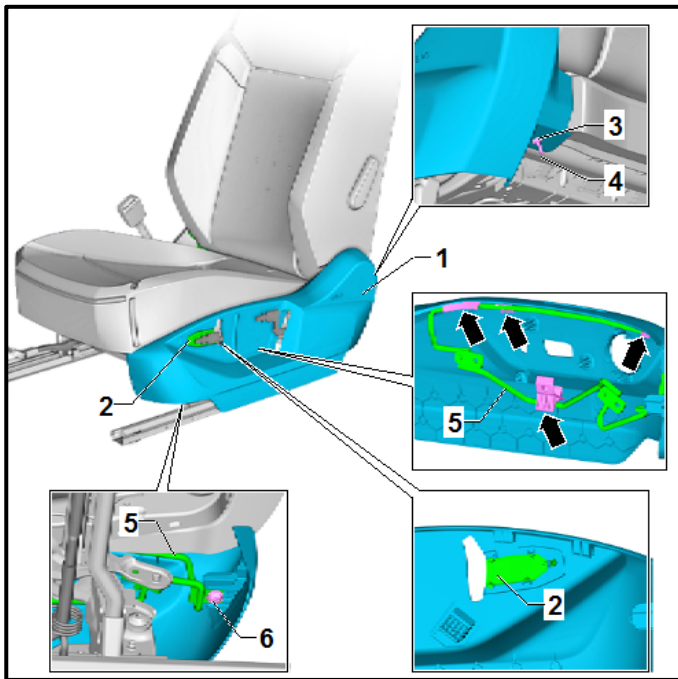

Remove seat side trim sill side (Depending on equipment):

- Remove the trim cap <2>.
- Press the clamping pin <4> toward the inside.
- Pry off the expanding rivet <3> using the Trim Removal Wedge -3409-.

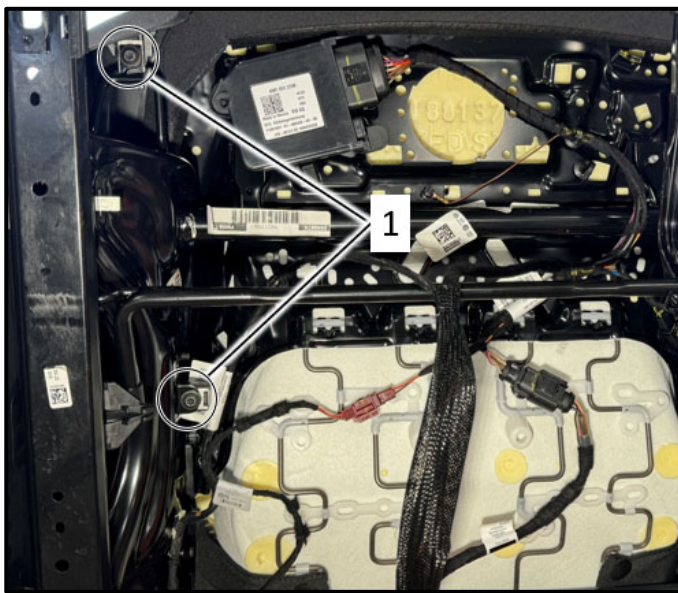

- Remove the bolts <1>.

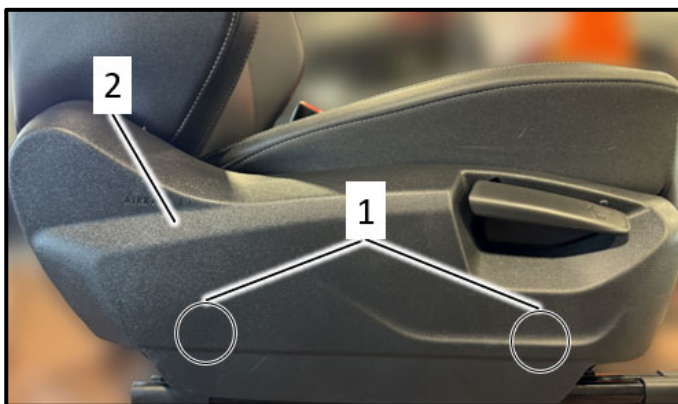

- Release the spring clips in the areas shown <1>.
- Remove the trim panel <2> by guiding it away from the seat frame.

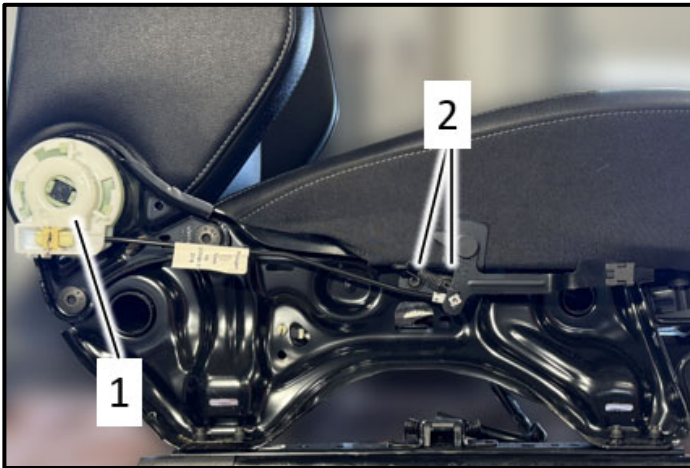

Remove backrest adjuster lever (Depending on equipment):

NOTE

The backrest adjuster <1> does not have to be removed during this repair.

- Remove the bolts <2>.
- Remove the backrest adjustment handle <1> by rotating it clockwise approx. 90° and disengaging the adjuster rod <2>.

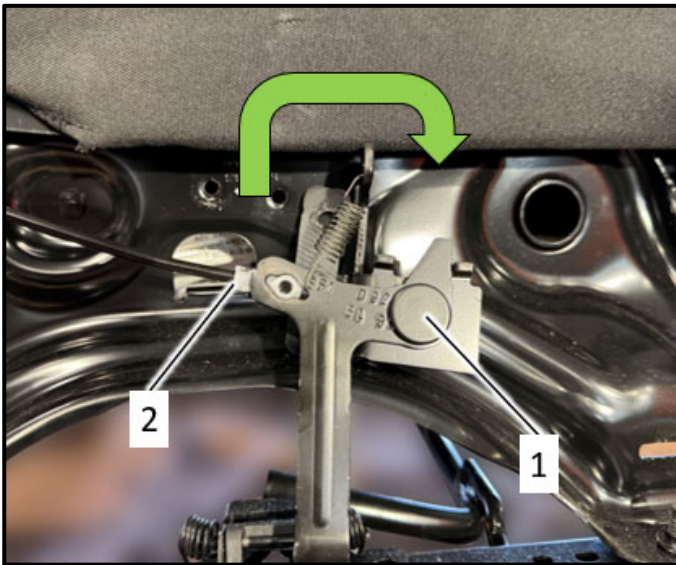

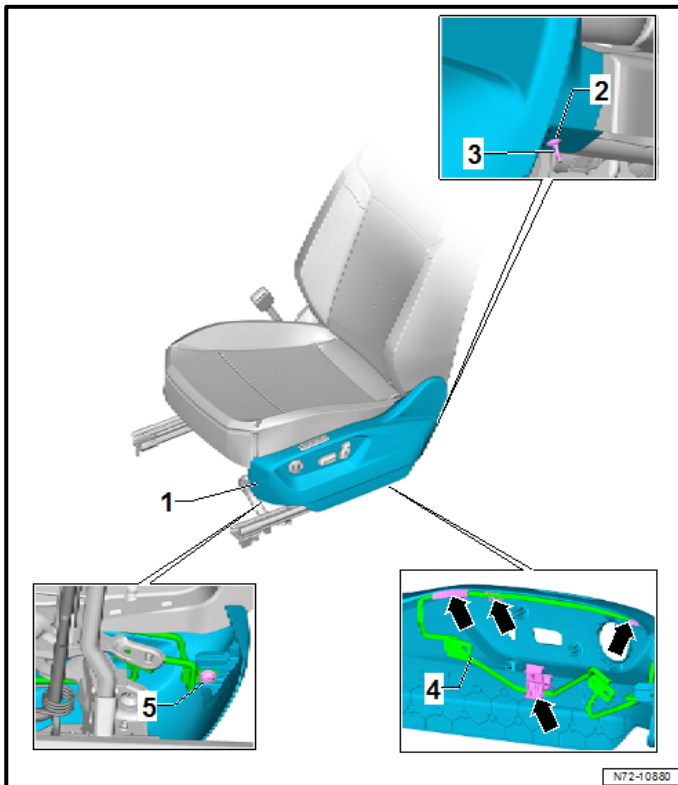

Remove seat side trim and bracket (Depending on equipment):

- Press the clamping pin <4> toward the inside.
- Pry off the expanding rivet <3> using the Trim Removal Wedge -3409-.
- Remove the bolt <5> from below.
- Remove the trim panel <1> from the bracket <4>, noting the attachment points <arrows>.

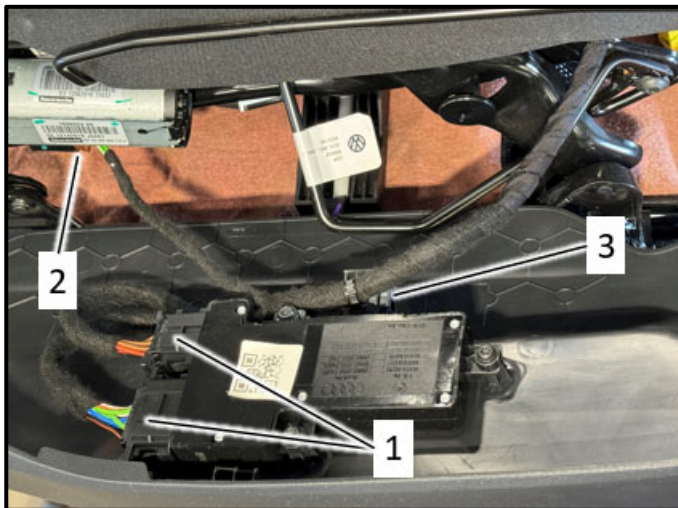

- Release the connectors <1> and <2>.
- Release the harness clip <3> from the cover.

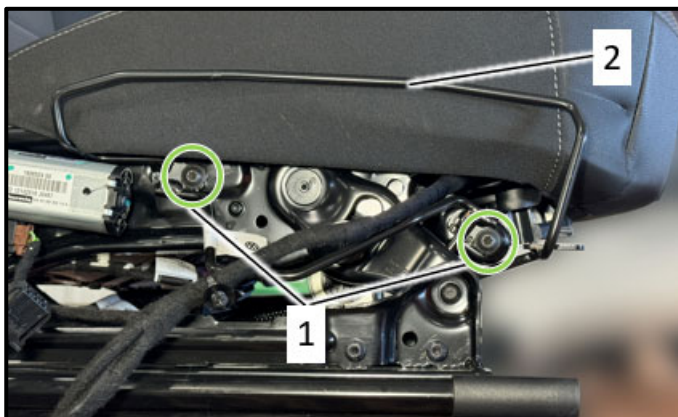

- Remove the bolts <1>.
- Guide out the bracket <2>.

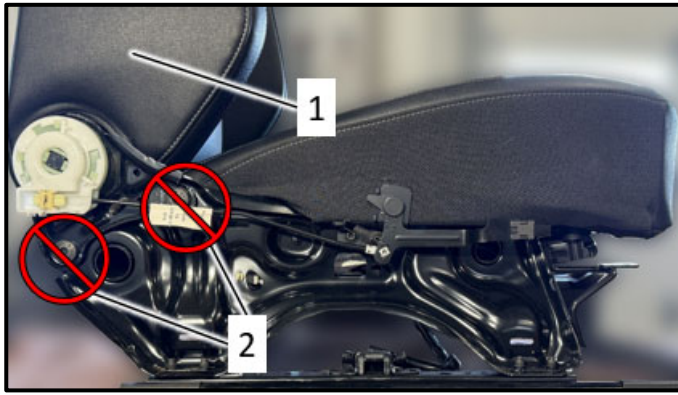

Remove lower seat cushion (all vehicles):

⚠ CRITICAL REPAIR STEP

STOP STOP STOP

The backrest <1> is **NOT** removed during this repair. Do not remove or loosen the back rest bolts <2>. Requests for additional time and/or parts for removal of the backrest will **NOT** be considered.

ⓘ NOTE

Manual seat shown. This critical repair step applies to power seats as well.

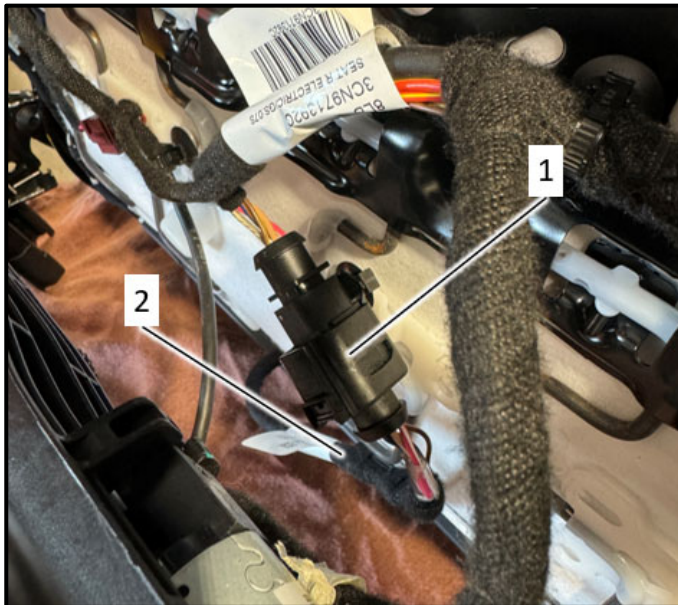

- Disconnect the occupancy detection mat connector <1>.
- Free up the wiring harness <2> from the seat frame.
- Take notes or clear pictures for the occupancy detection mat harness routing.

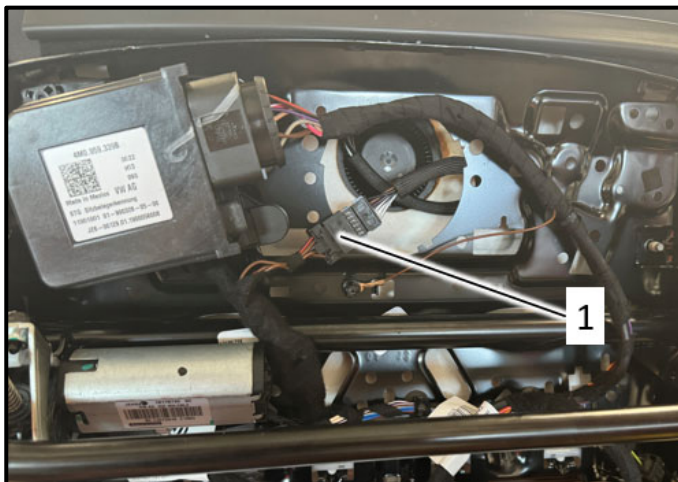

- Vehicles equipped with ventilated seats:
 - Disconnect the fan connector <1>.

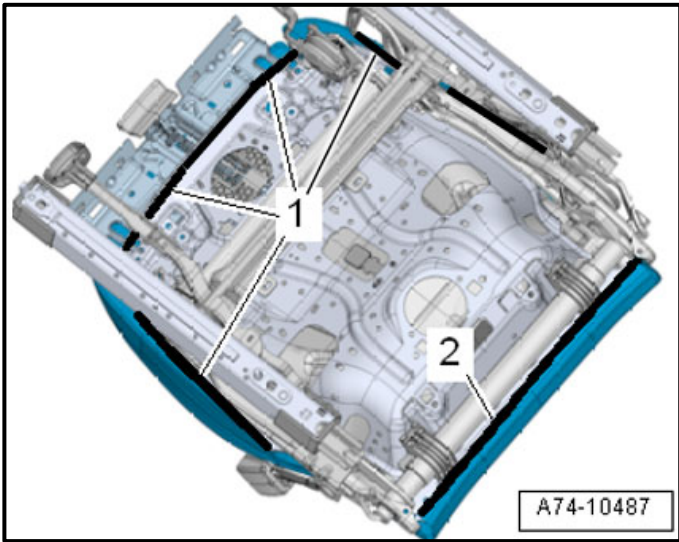

- Disengage the molding strips <1> and <2> using the T-Handle Hook -3438-.

NOTE

Higher force is required, to disengage the front and side molding strips <1>.

TIP

A long 90° hose pick or a long flathead screwdriver can aid in disengaging the molding strips.

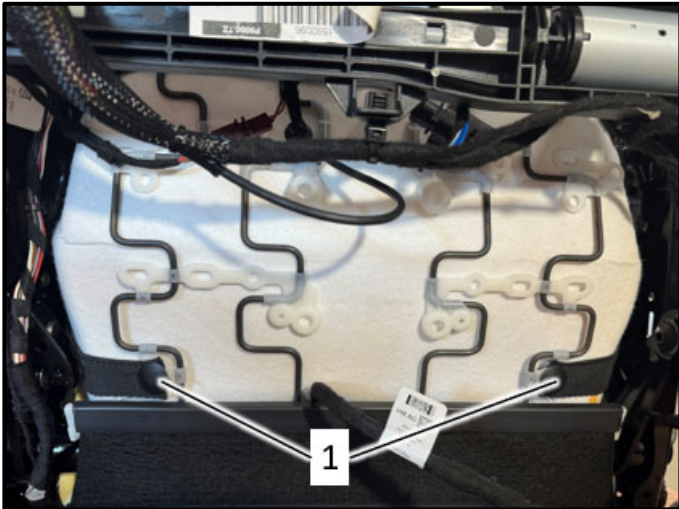

- Release the seat cover tensioning strap clips <1>.

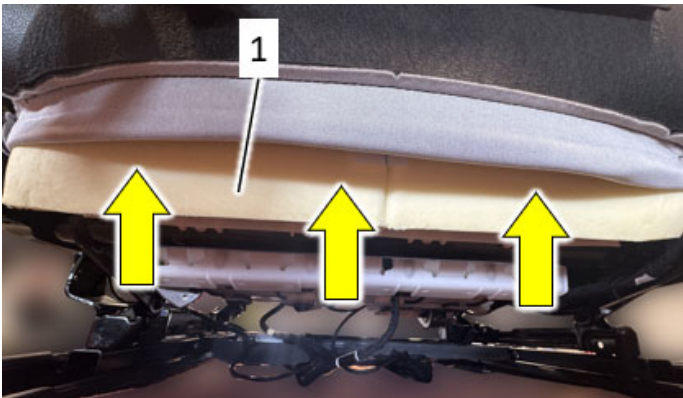

- Push the seat cushion <1> up and over the seat frame, towards the front of the seat <arrows>.

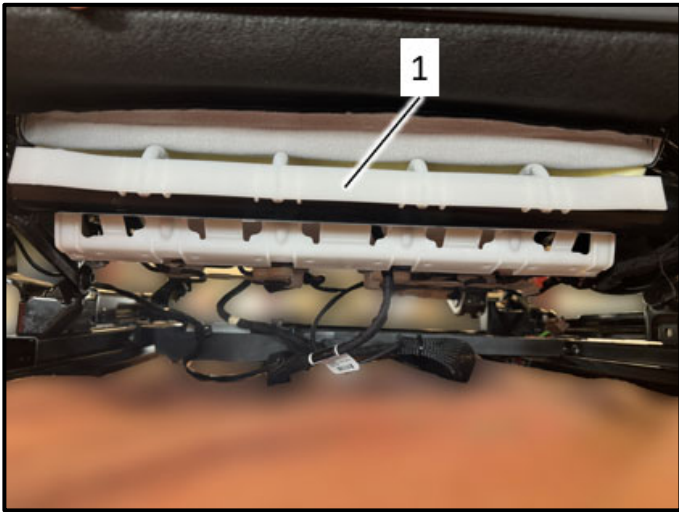

NOTE

The seat pictured has had the cushion pushed up and over the plastic frame <1> and the cushion is ready for removal.



- Remove the seat cushion <1> from the seat frame in the direction indicated <arrows>.

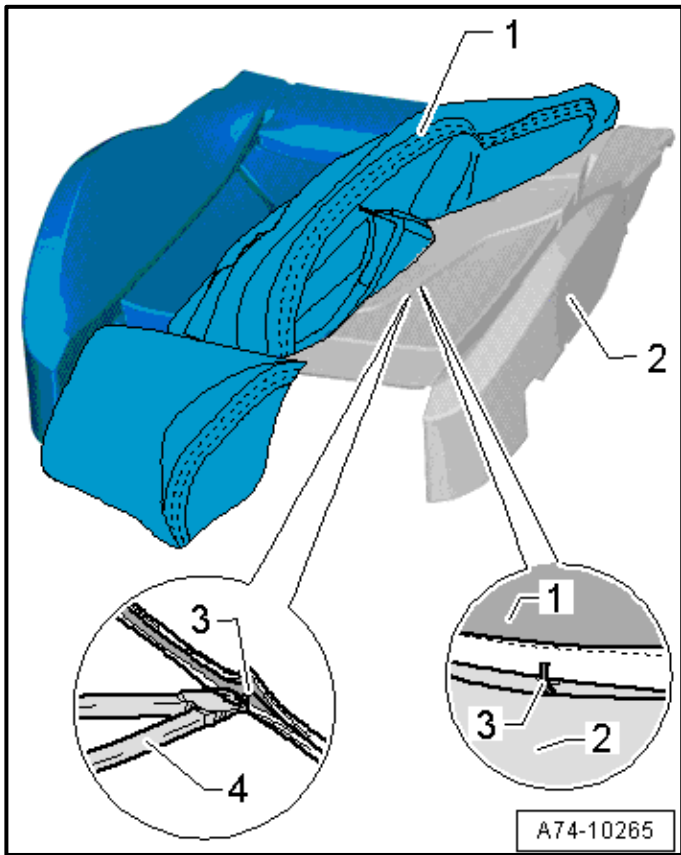

Separating seat cover and cushion:

- Peel back the seat cover <1> from the seat cushion <2> to expose the upholstery clips.
- Cut through the upholstery clips <3> with suitable pair of pliers <4>.

NOTE

The seat cover will have approximately 16 upholstery clips installed. While cutting these clips, some fragments may remain attached to the seat cover and/or cushion. ALL fragments of the old clips MUST be removed from the seat cover and cushion prior to reassembling the seat.



Removing occupancy detection mat:

⚠ CAUTION

Risk of Injury!

The surface of occupancy detection mat will be hot. Wear protective gloves.

⚠ CAUTION

Risk of Consequential damage!

The seat foam can be damaged. Do not use a high heat setting. Keep the heat gun moving. Do not hold the heat gun in one location.

⚠ CAUTION

There may be a slight odor when heating the mat. Perform the repair in a well-ventilated area.

! NOTE

Ventilated seat shown. Removal of the occupancy detection mat is similar for other seat variants.

- Use a heat gun set to Low/Medium heat.
- Alternately heat the seat occupancy mat surface still adhered to the seat cushion while carefully and slowly pulling the sensor mat away from the seat cushion.
- Only pull upward at a very slight angle.
- DO NOT pull up perpendicular to the seat cushion surface.
- Remove each section equally.
- Carefully pull wiring harness through the seat cushion.

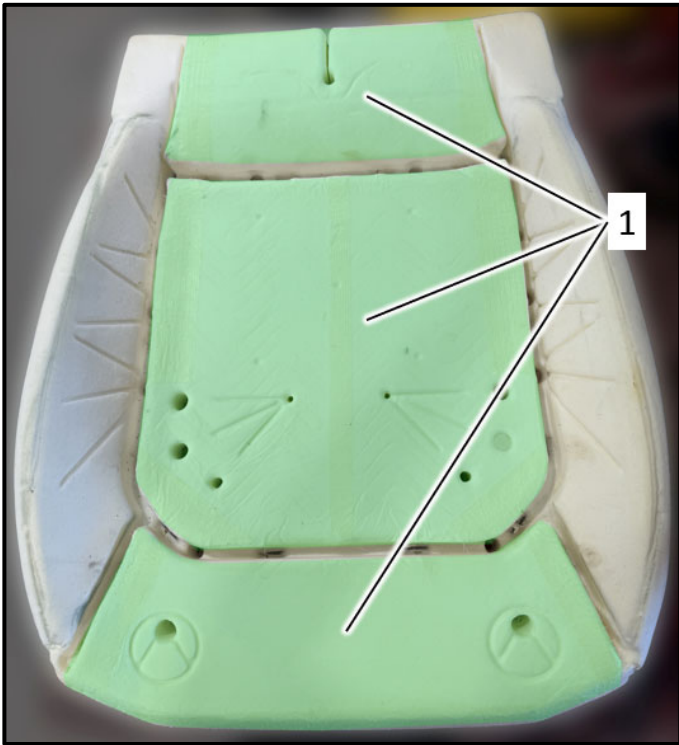

⚠ CAUTION

Lack of adhesion risk!

After removal of the occupancy detection mat, there will be adhesive residue left on the seat cushion in the highlighted areas <1>. DO NOT touch the remaining adhesive or allow it to become contaminated. If contaminated, the new sensor mat may not adhere properly.

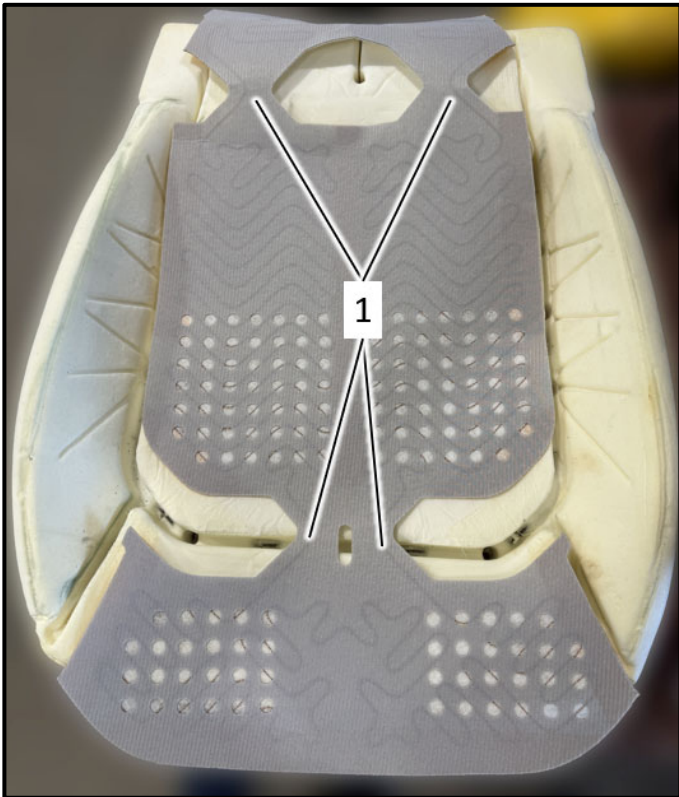

Seat occupancy detection mat installation:

- Remove the protective backing from only one section of the occupancy detection mat at a time.
- Adhere only one section of the occupancy detection mat to the seat cushion at a time.
- Ensure that the occupancy detection mat is properly adhered to the seat cushion.
- Ensure each “bridge section” <1> is pressed evenly into the valleys of the seat cushion.

! NOTE

Ventilated seat shown. Installation of the occupancy detection mat is similar for other seat variants.



Reinstall seat cover:

CAUTION

Ensure the sensor mat is not damaged/pinched when installing clamps.

- Installation is the reverse order of removal.
- Install new upholstery clips using Upholstery Clip Pliers -VAG1634B-.

TIP

For non-ventilated seat variants, start at the center rows and work outward.

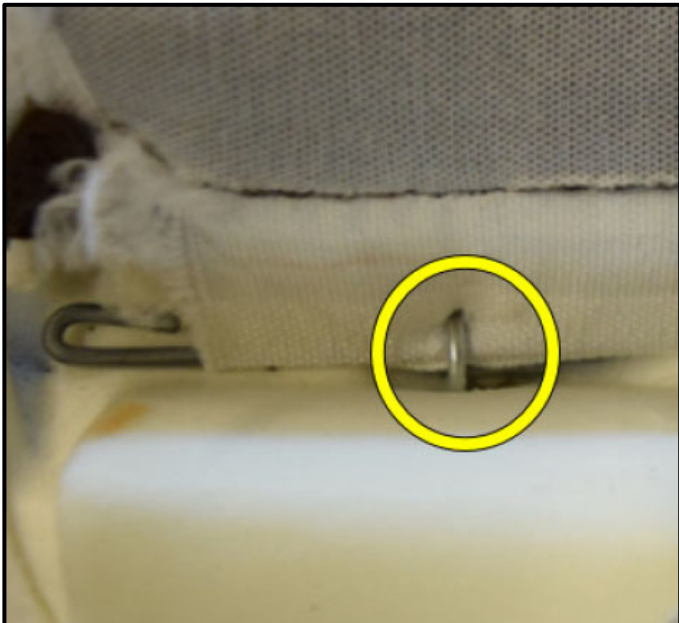

- Prior to fully clamping the upholstery clips closed, be sure each upholstery clip engages BOTH the webbing on the bottom side of the seat cover AND the fastening wire molded into the seat cushion as shown <circle>.

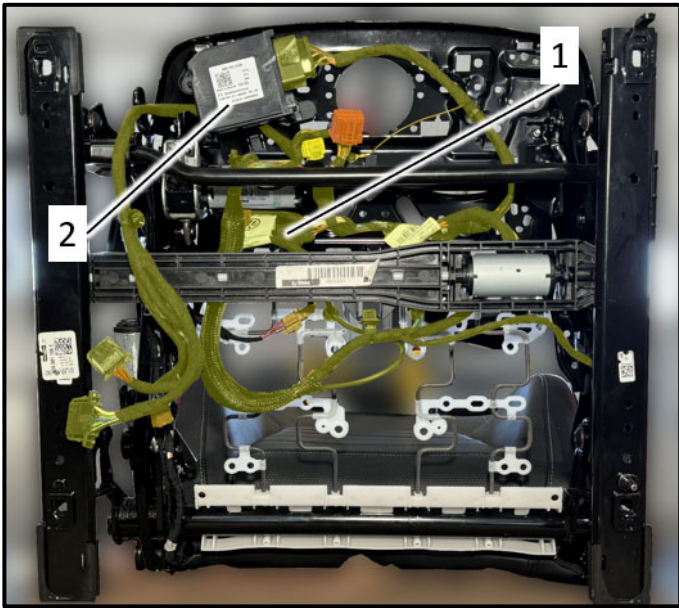

Seat harness replacement:

- With the seat cushion still removed, replace the seat harness <1>.
- Vehicles equipped with power adjustable passenger seats:
 - Remove the PODS module and bracket <2>, taking note of the harness routing.

! NOTE

Ventilated seat shown. Installation of the seat harness is similar for other seat variants.

! NOTE

The seat back harness is not replaced during this repair, only the harness pictured <1>.

i TIP

Installing the new seat harness as the old one is removed can aid in proper routing of the new harness.

- Torque the bolted ground connection <1> to 5 Nm.

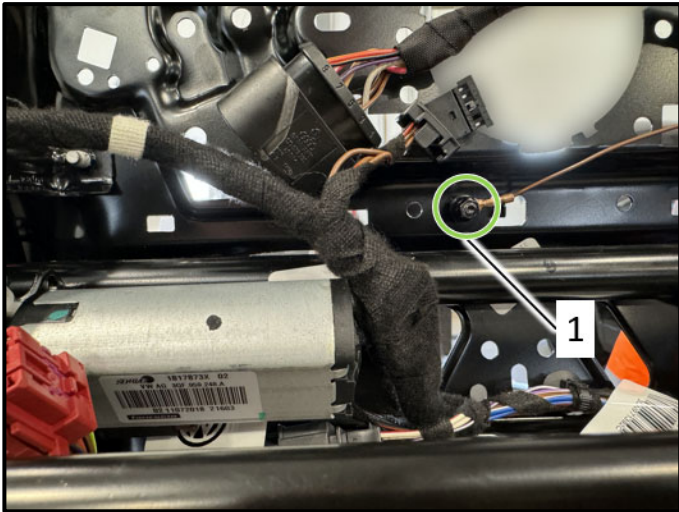

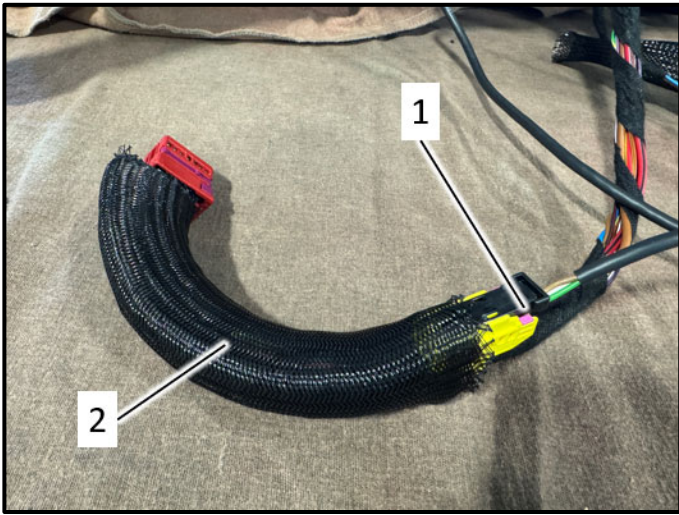

- The airbag harness <1> is not replaced during this repair and must be fed through the wire loom <2> of the new wiring harness.

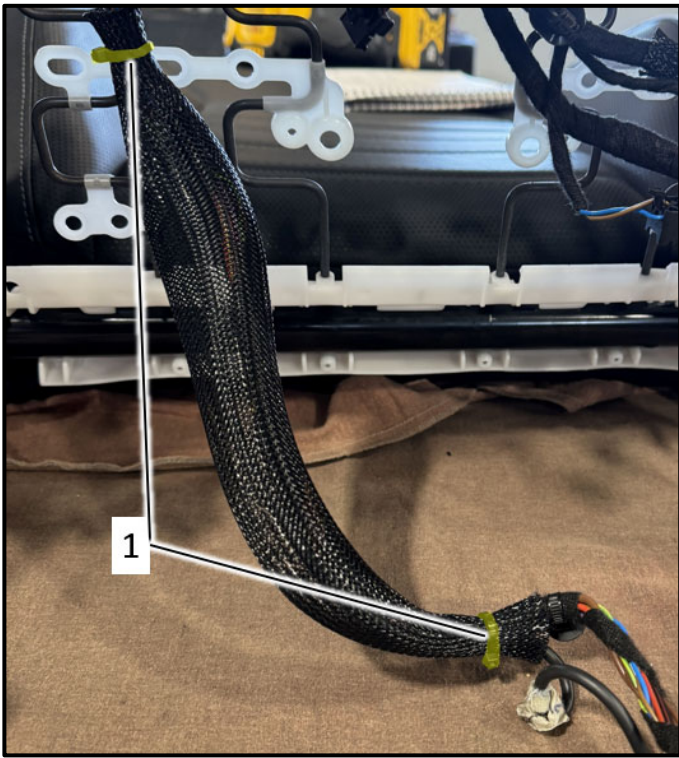

- Secure the new wire loom using two tie wraps <1>.

Part Number	Part Description
N -106-622-01	Tie wrap (up to 3)

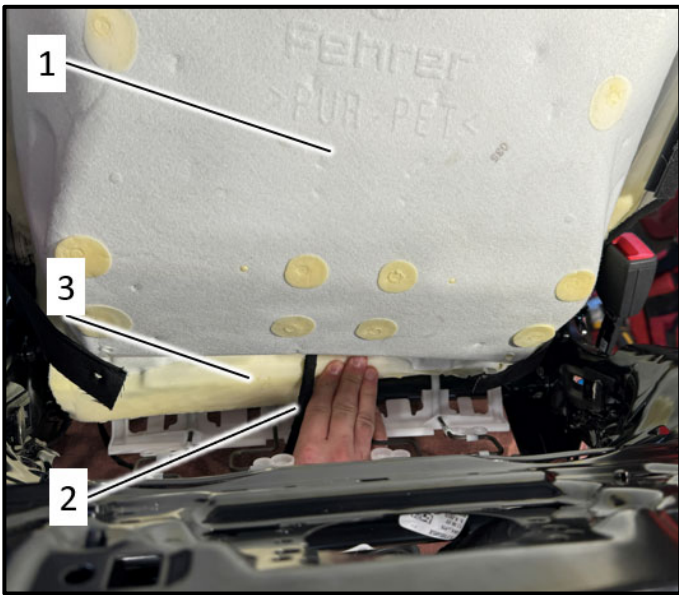

Reinstall seat cushion:

- Place the seat cushion <1> back on to the seat frame, ensuring proper routing of the occupancy detection harness <2>.
- Lift the front of the seat cushion <1> and feed the rear of the seat cushion <3> between the backrest and the seat frame.

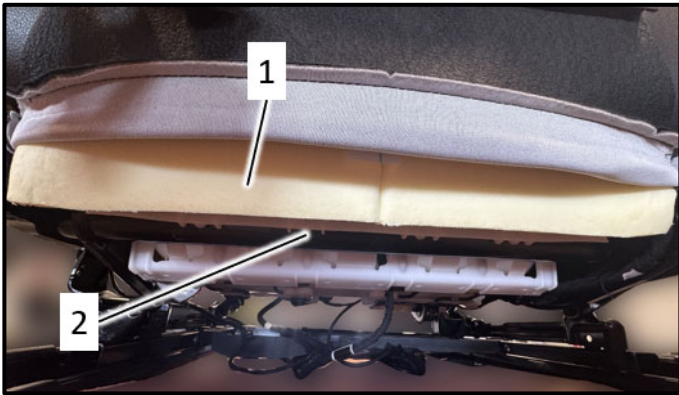

- Ensure the seat cushion <1> has been fully fed through the seat frame <2>.

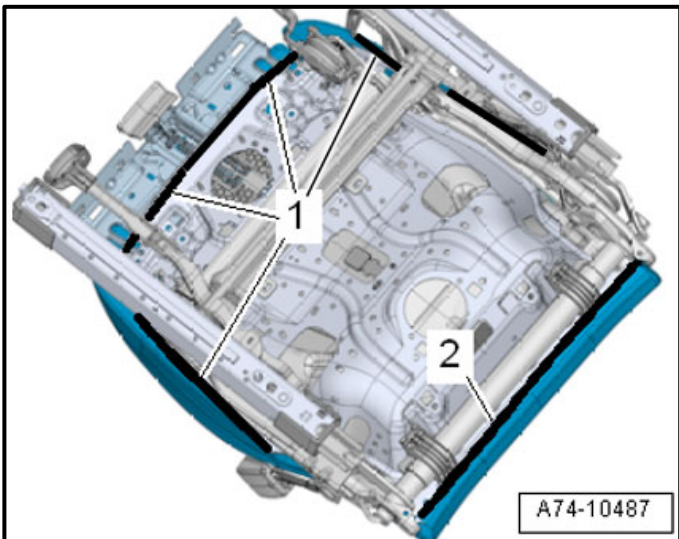

- Engage the moldings <1> and <2> onto the seat pan.

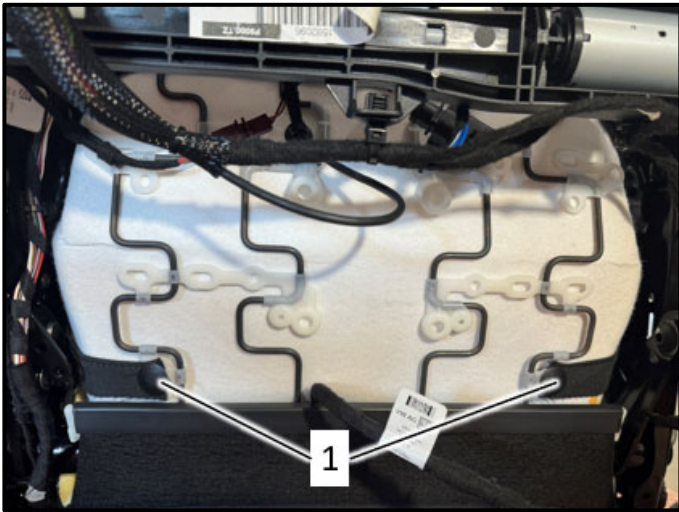

- Secure the seat cover tensiing straps <1>.

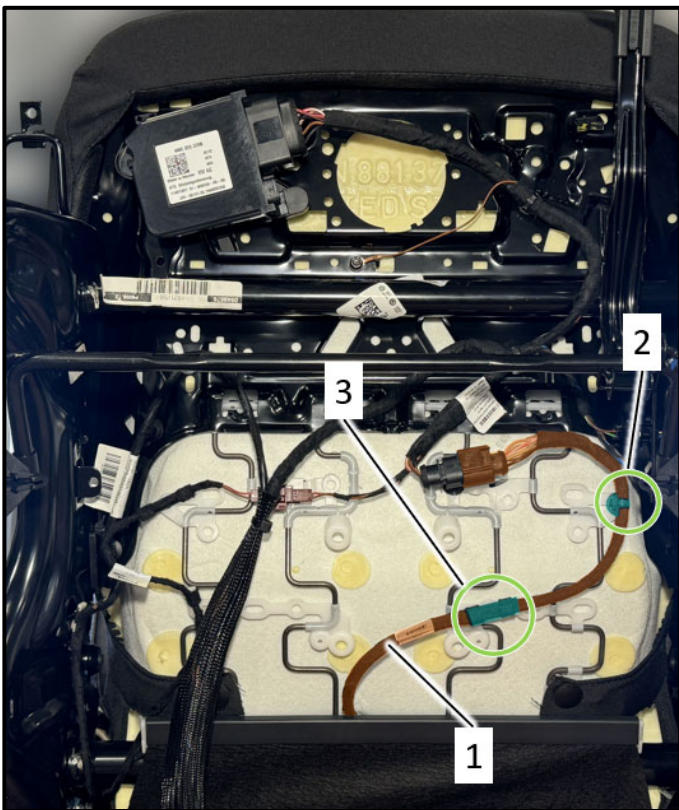

! NOTE

The new seat occupancy detection mat harness <1> is longer than the original and includes an additional securing clip <2>.

! NOTE

Manual seat shown for clarity purposes. Installation is similar for other seat variants.

- Route the seat occupancy detection harness <1> as shown.
- Attach the harness clips <2> and <3> to the seat frame in the positions shown.

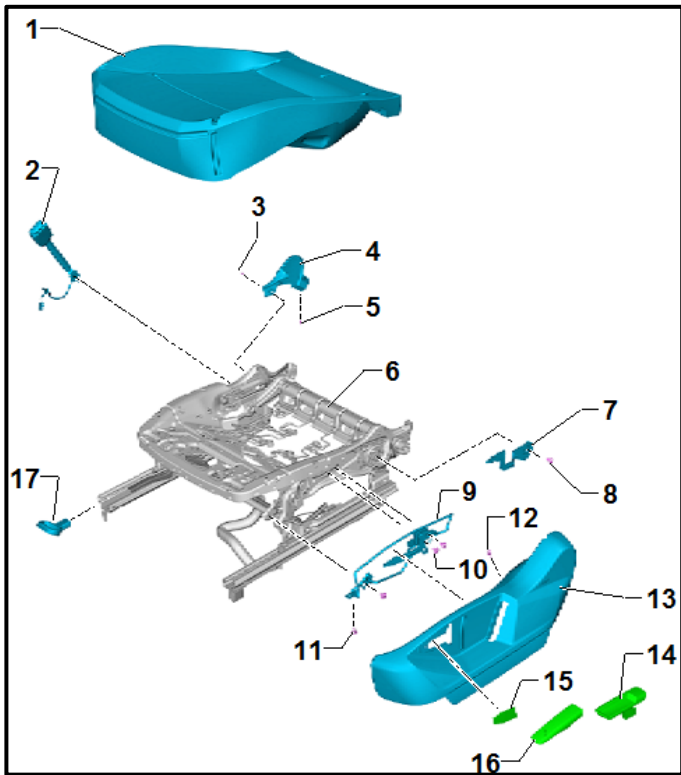

Reassemble the seat trim and adjustment components:

- Installation is the reverse order of removal.
- Connect and secure seat electrical connectors.
- Torque fasteners for the seat trim bracket (power seats) and backrest adjustment handle (manual seats) to 8 Nm.
- Torque the sill side trim panel bolts to 2 Nm.

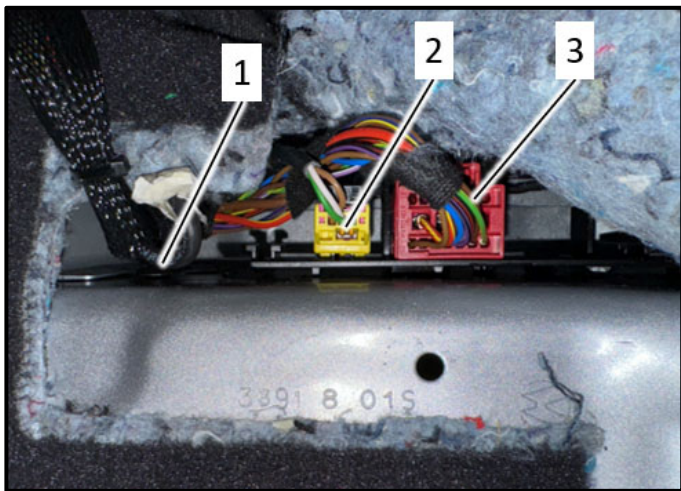

Reinstall passenger front seat:

- Place seat back into the vehicle.

⚠ WARNING

Before handling pyrotechnic components (for example, disconnecting the connector), the person handling it must “discharge static electricity”. This can be done by touching the door striker, for example.

⚠ WARNING

Follow the general safety precautions when working with airbags, belt tensioners and battery cut-out units (pyrotechnic components).

- Disconnect the -VAS6282- from the thorax airbag harness connector.
- Secure the harness to the body using the attached clip <1>.
- Reconnect connectors <2> and <3>.

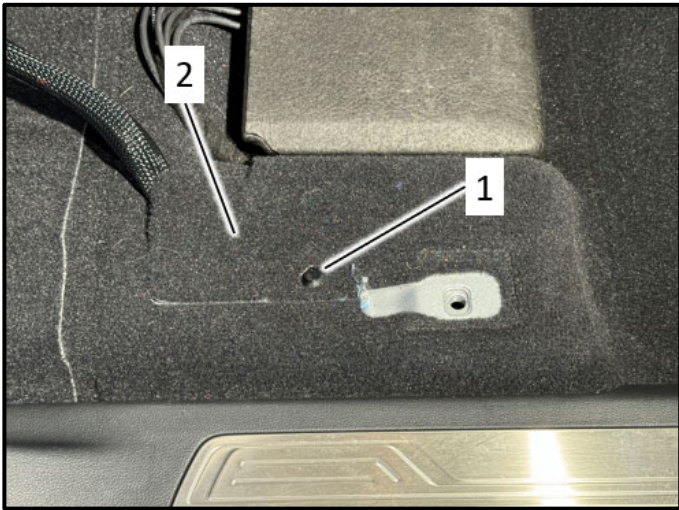

- Close the carpet cover <2>.
- Install expanding rivet <1>.

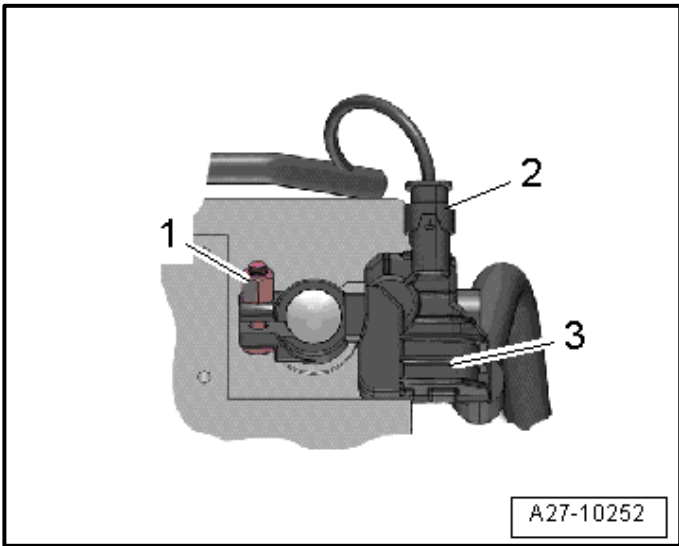

Reconnect the battery:

⚠ WARNING

Make sure that no persons are in the vehicle.

- Disconnect the connector <2> from the Battery Monitoring Control Module -J367- <3>.
- Install the battery ground cable terminal clamp by hand on the battery negative terminal.
- Tighten the nut <1> to 6 Nm.
- Reconnect the connector <2> to the Battery Monitoring Control Module -J367-.
- Check time and adjust if necessary.
- Open and close the windows all the way.
- Then, with the windows closed, pull the power window switch until the relay audibly switches.
- Check the window regulator convenience switch.

! NOTE

After reconnecting the power supply, the ESC warning lamp can only go out after the vehicle has been driven a few meters.

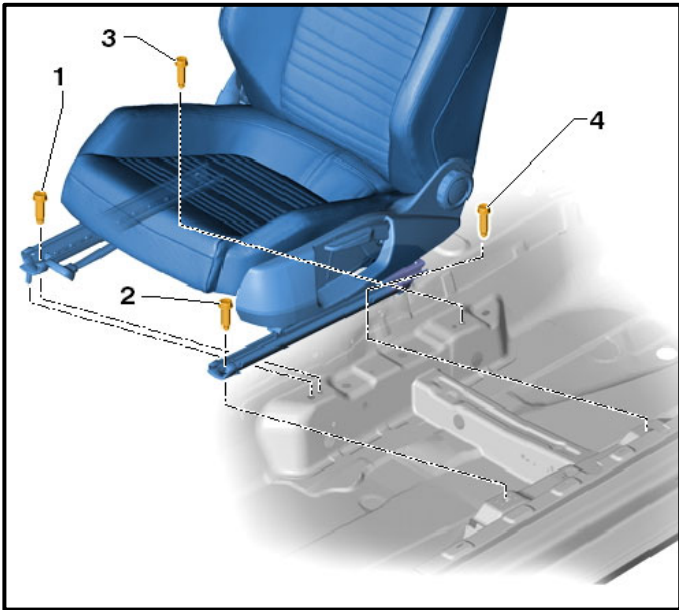

- Install and torque the seat bolts to 40 Nm.

⚠ WARNING

When installing the seat, if a thread in the seat crossmember mounting plate was damaged, a reworking of the damaged thread is forbidden. In this case, the seat crossmember mounting plate must be replaced.

Proceed to Section C

Section C – PODS Basic Settings

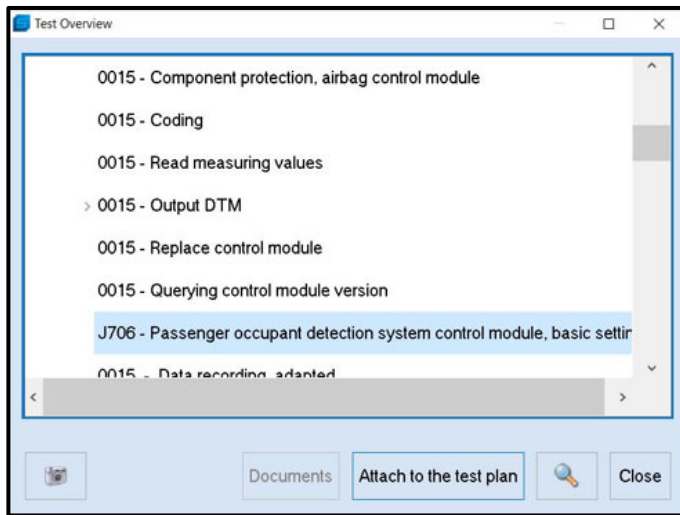

Perform PODS basic settings:

- Install the battery charger.
- Switch the ignition on.
- Connect the scan tool and start a GFF scan of the vehicle using ODIS.
- Through the self-select test plan option, select the test plan for the PODS basic settings:
 - *Self-Select Test Plan > Diagnosis capable systems > 0015 - Airbag > 0015 - Airbag Functions > J706 – Passenger occupant detection system control module, basic settings.*
- Perform the test plan and follow the on-screen prompts.
- Exit the GFF session and send the diagnostic protocol online.

Proceed to section D

Section D – Campaign Completion Label

Install Campaign Completion Label

- Fill out and affix Campaign Completion Label, part number CAMP 010 000, next to the vehicle emission control information label.



TIP

Ensure Campaign Completion Label does not cover any existing label(s).

- **Proceed to Section E**

Section E - Parts Return/Disposal

Properly store (retain), destroy or dispose of removed parts in accordance with all state/province and local requirements, unless otherwise indicated and/or requested through the Warranty Parts Portal (WPP) for U.S. and the Part Destruction and Core Disposition Report for Canada.

Appendix A – Warning and Safety Precautions

WARNING

General Safety Precautions when Working with Pyrotechnic Components:

- Pyrotechnic components always contain propellant that generates a gas during combustion. In some components, there is also a supply of pressurized gas to ensure this gas is generated
- This pressurized gas is stored under high pressure in a compressed gas container. Pyrotechnic components are triggered by electrical/mechanical igniters.
- Only trained personnel should perform testing, assembly and servicing work. Airbags do not have a replacement interval.
- Never check with test lamps, voltmeter or ohmmeters.
- Only check pyrotechnic components when they are installed in the vehicle using vehicle diagnosis, testing and information systems approved by the manufacturer.
- When working on pyrotechnic components and the airbag control module, disconnect the battery ground strap while the ignition is switched on. Then cover the negative terminal.
- Wait 10 seconds after disconnecting the battery.
- The ignition must be SWITCHED ON when connecting the battery. There should not be anyone inside the vehicle when doing this.
- Exception: vehicles with batteries in the passenger compartment. In this case, stay outside the range of the airbags and seat belts.
- Wash your hands after touching ignited pyrotechnic components from the restraint system.
- Do not open or repair pyrotechnic components. Use only new components to reduce the risk of injury.
- Do not install pyrotechnic components that have fallen onto a hard surface or show signs of damage.
- Discharge static electricity before handling pyrotechnic components, for example before disconnecting the electrical connector. This can be done by touching grounded metal objects such as the door striker pin.
- Install pyrotechnic components immediately after removing them from their transport packaging. If you must stop working, store the pyrotechnic component in its original transport packaging.
- Do not leave pyrotechnic components lying in the open unattended.
- Do not treat pyrotechnic components with grease, cleaning solutions or similar products.
- Do not expose pyrotechnic components to temperatures above 100 °C, even for brief periods of time.