



# SAFETY RELATED RECALL

Global Recall Action  
Number: N908

Changes are highlighted in blue

<b>Subject:</b>  <b>Ingenium I6 3.0L Diesel and Petrol Oil Filter Cap - Renew</b>	Publication No.: N908
	Model: Defender (LE)
	Model Year: 2024 - 2025
	Model: Discovery (LR)
	Model Year: 2024 - 2025
	Model: Range Rover (LK)
	Model Year: 2024 - 2025
	Model: Range Rover Sport (L1)
	Model Year: 2024 - 2025
	Model: Range Rover Velar (LY)
	Model Year: 2024 - 2025
	Date of Issue: 14 June 2024

<b>To:</b>	All National Sales Companies (NSCs), importers, retailers and authorized repairers.  JLR North America, LLC and JLR Canada ULC.
<b>For the Attention of:</b>	The approved JLR retailer/authorized repairer.
<b>Important:</b>	NOTE: The information in this campaign is intended for use by professional technicians. If you are not a JLR retailer/authorized repairer, do not assume that a condition described affects a specific vehicle. Contact an authorized JLR retailer/authorized repairer to determine if this campaign applies to a specific vehicle.  This campaign supersedes Update Prior to Sale (UPS) notice UPSUPS2924-1 with immediate effect. The blue highlighted text relates only to the date information. All text in this campaign should be read and understood in full.

## FOR THE ATTENTION OF ALL:

### DESCRIPTION OF ISSUE AND THE EFFECT ON VEHICLE OPERATION

A concern has been identified where the incorrect specification of plastic was used to manufacture the oil filter housing. The incorrect specification plastic housing will, over time and with vehicle use, crack allowing oil to leak out onto the engine and into the engine compartment.

An oil leak under pressure in this area could result in oil coming into contact with hot components on the engine which may result in a fire. Additionally, oil may leak onto the road surface posing a skid hazard to other road users especially two wheeled vehicles, and increase the risk of a crash.

### ACTION TO BE TAKEN

JLR has taken the decision to recall affected vehicles to repair the vehicle.

Following procedures appropriate to your market and as required by local legislation, owners of affected vehicles should be contacted requesting that the owner contact their nearest JLR retailer/authorized repairer as soon as possible to arrange for the repair to be completed. The National Sales Companies (NSCs), Importer, Regional Office or Government agency will contact the customers. If you have any questions about this process, contact your NSC/Importer or Regional Office for more information.

Check the JLR Warranty Portal to make sure affected vehicles are correctly identified prior to starting this campaign. The Warranty Portal will be updated to reflect only those vehicles affected.

JLR retailers/authorized repairers are reminded that they must not sell vehicles identified as affected by this campaign until such time as the repair has been successfully completed.

An owner may indicate that a repair has already been completed for this concern, in which case the full cost of the repair should be reimbursed. Refer to the warranty section of this campaign for details of the Customer Reimbursement and Related Damage Process. At the time of confirming a booking for a vehicle repair, make sure you check the Warranty Portal to confirm if there are any other outstanding campaigns, to make sure the correct parts are available and adequate workshop time is allocated for repairs to be completed in one visit.

For information purposes, a Technical Question and Answer document is attached.

**FOR THE ATTENTION OF NORTH AMERICAN TERRITORIES ONLY:**

National Highway Traffic Safety Administration (NHTSA) reference number:TBD

Transport Canada (TC) reference number:TBD

Visit the British Brands Sales Suite (BBSS) website for a list of affected vehicles at your JLR retailer/authorized repairer. Unsold vehicles must be repaired prior to handover of the vehicle for retail sale.

	<p><b>The following applies to:</b> [NORTH AMERICA]</p>
-----------------------------------------------------------------------------------	-------------------------------------------------------------

**REGULATORY INFORMATION**

	<p><b>The following applies to:</b> [NORTH AMERICA]</p>
-------------------------------------------------------------------------------------	-------------------------------------------------------------

JLR North America, LLC and JLR Canada ULC will inform the National Highway Traffic Safety Administration (NHTSA) and Transport Canada (TC) of their intent to perform a Safety Recall on certain Defender, Discovery, Range Rover, Range Rover Sport and Range Rover Velar 2024 and 2025 model year vehicles imported into the United States and Canadian markets. Information relating to this Safety Recall will be posted on the NHTSA and TC websites. United States Federal regulations require that JLR retailers/authorized repairers must be notified within a reasonable time after the manufacturer decides that a defect that relates to motor vehicle safety or a non-compliance exists. United States Federal Law requires JLR retailers/authorized repairers to complete any outstanding Safety Recall before a new vehicle is delivered to the buyer or lessee. Violation of this requirement by a JLR retailer /authorized repairer, in the USA only, could result in a maximum civil penalty of up to the equivalent of \$27,168.00 USD per violation and the equivalent of \$135,828,178.00 USD for a related series of violations. This Safety Recall serves as notification to all JLR retailers/authorized repairers in the United States and Federalized Territories and Canada that any affected new vehicles may not be sold and delivered for customer use until the Safety Recall repair is completed.

	<p><b>The following applies to:</b> [NORTH AMERICA]</p>
-------------------------------------------------------------------------------------	-------------------------------------------------------------

JLR North America, LLC and JLR Canada ULC recommends that affected sales demonstrator and loaner vehicles are repaired before use, and that used vehicles are repaired before sale. JLR retailers/authorized repairers who proceed against this recommendation, where legally permitted, must clearly and conspicuously disclose the open Safety Recall notice to the applicable customers.

Yours faithfully

Steve Oldham

Global Customer Care Quality Director

## SERVICE INSTRUCTION - N908

### Parts Information

The parts below should be ordered through JLR in the normal manner.

Description	Part Number	Qty
Oil filter housing	LR133514	1
Oil filter element	LR133455	1

\* When ordering parts, order no more than the expected percentage failure rate of parts identified

### SROs

Description	SRO	Time
Oil filter element and housing renew	05.10.20	0.2
Drive in/drive out	02.02.02	0.2



#### NOTE:

Repair procedures are under constant review, and therefore times are subject to change; those quoted here must be taken as guidance only. Always refer to TOPIx to obtain the latest repair time.

### Warranty Information

Warranty claims should be submitted quoting program code N908 with the relevant option code from the table below. As option codes are used there is no requirement for you to enter SROs or parts, these are included for information only.

Program Code	Option	Description	SRO	Time	Part Number	Qty
N908	A	Oil filter element and housing renew	05.10.20	0.2	LR133514	1
					LR133455	1
N908	B	Oil filter element and housing renew	05.10.20	0.2	LR133514	1
		Drive in/drive out	02.02.02	0.2	LR133455	1



#### NOTE:

The option that contains the drive in/drive out allowance may only be claimed when the vehicle has been brought back into the workshop for this action alone to be undertaken.

Warranty claims should be submitted in accordance with the current JLR Global Warranty Manual, and its amendments, unless stated otherwise in this bulletin.

### Customer Reimbursement and Related Damage Process



#### NOTE:

If there is a requirement to claim for related/consequential damage or customer reimbursement, refer to the related instruction that can be found in TOPIx (in the Search box, search for 'Related Damage Claim' and open the related bulletin link).

## SERVICE INSTRUCTION

Ingenium I6 3.0L Petrol Vehicles Only

1. Remove the engine cover (see TOPIx Workshop Manual Section 501-05: Removal and Installation - Engine Cover - INGENIUM I6 3.0L Petrol).

Ingenium I6 3.0L Diesel Vehicles Only

2. Remove the engine cover (see TOPIx Workshop Manual Section 501-05: Removal and Installation - Engine Cover - INGENIUM I6 3.0L Diesel).

3. If equipt, remove the [Noise, Vibration and Harshness \(NVH\)](#) cover.

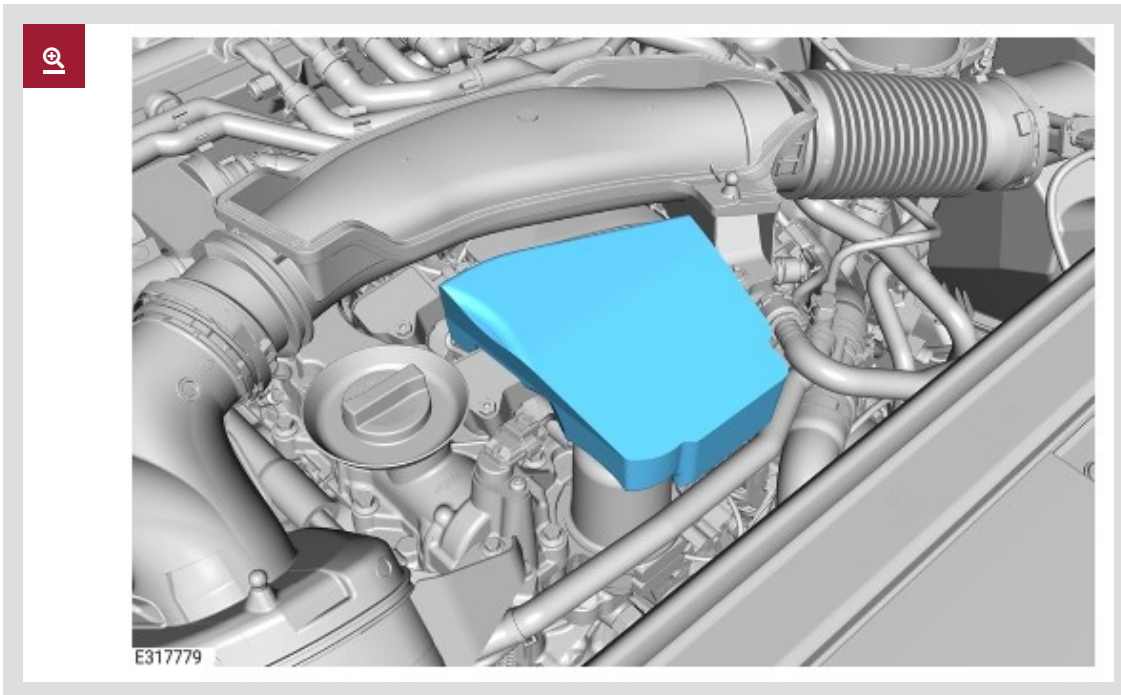

4. Loosen the oil filter element cap 4 complete turns.

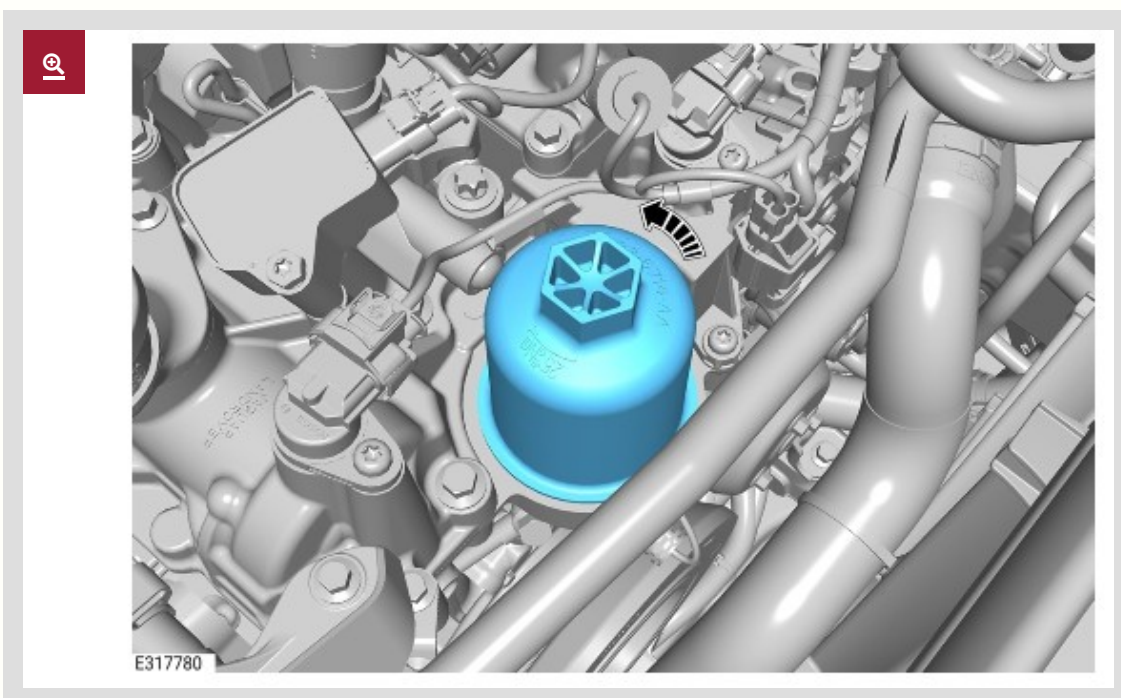

5. Remove and discard the oil filter element cap and the oil filter element.

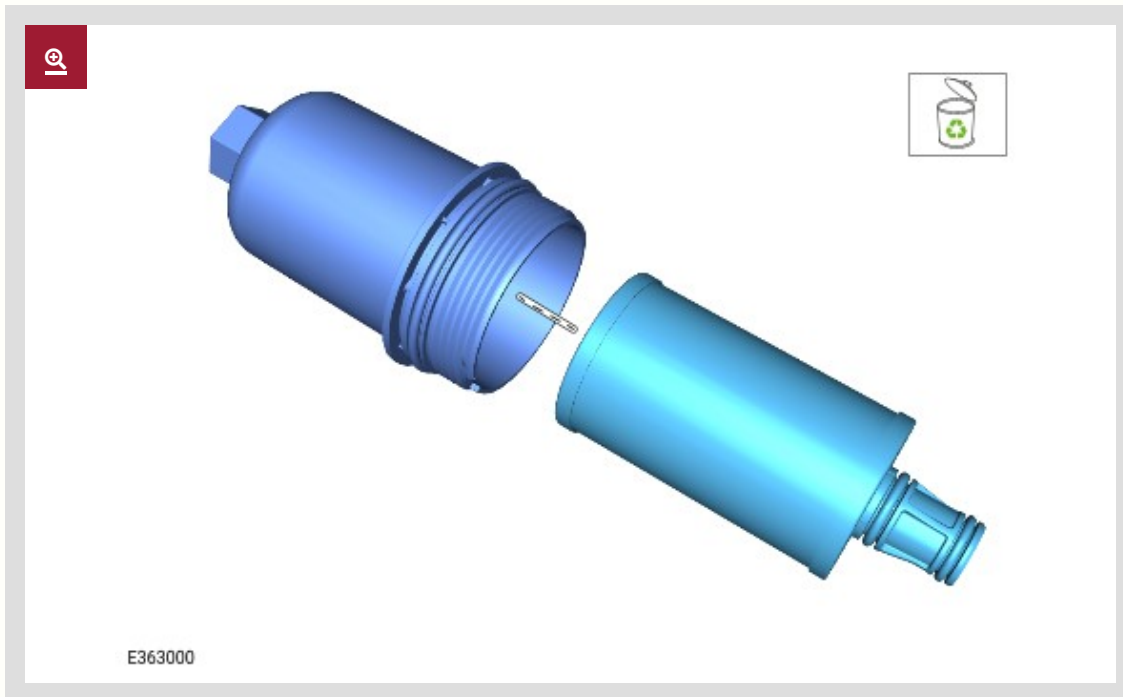

6. Install a new oil filter element. Make sure the oil filter element is pushed correctly onto the bypass valve inside the oil filter element cap (C).

- Lubricate the oil filter element cap O-ring (A) and oil filter element O-ring (B) with clean engine oil.

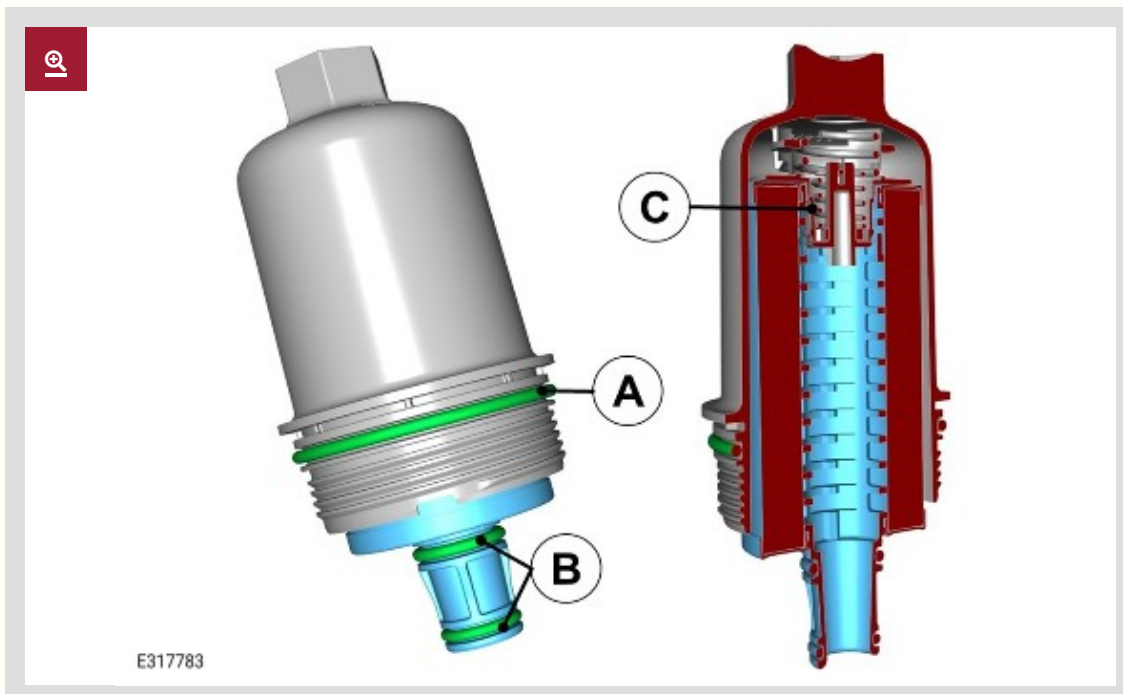

7. Install and tighten the oil filter element cap.

- Torque: **25 Nm**

8. Start the engine and allow to idle for 2 minutes.

- Check for leaks.
- Stop the engine.

9. If equipt, install the [NVH](#) cover.

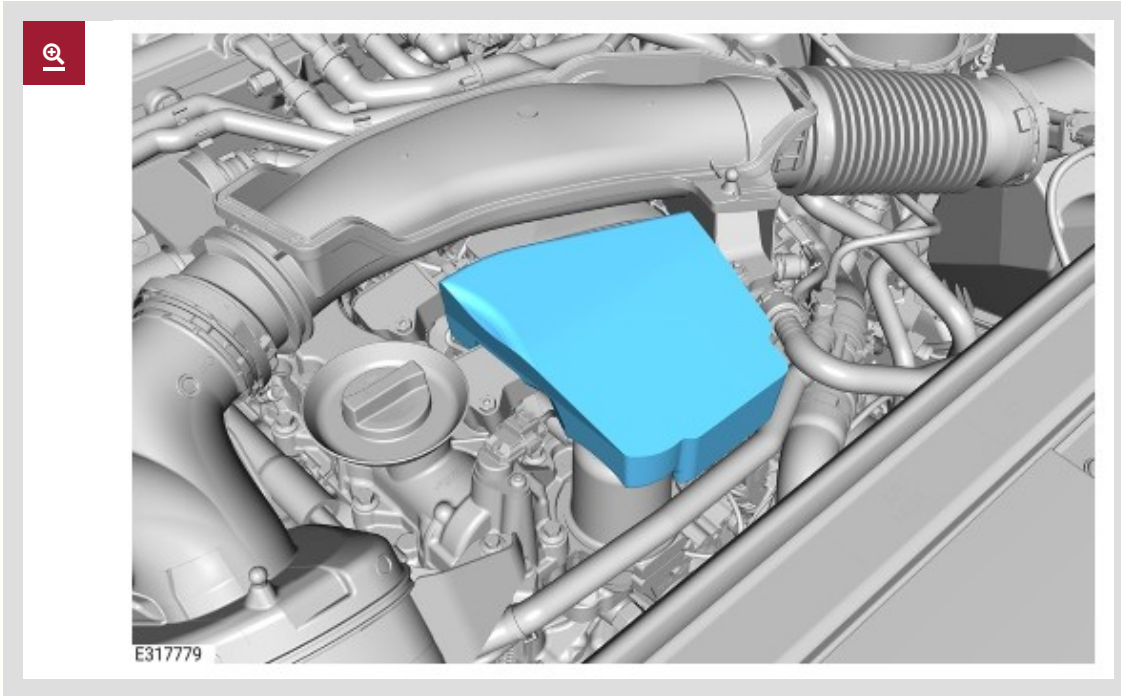

Ingenium I6 3.0L Petrol Vehicles Only

10. Install the engine cover (see TOPIx Workshop Manual Section 501-05: Removal and Installation - Engine Cover - INGENIUM I6 3.0L Petrol).

Ingenium I6 3.0L Diesel Vehicles Only

11. Install the engine cover (see TOPIx Workshop Manual Section 501-05: Removal and Installation - Engine Cover - INGENIUM I6 3.0L Diesel).

## **SAMPLE CUSTOMER LETTER - FOR INFORMATION ONLY**

Name  
Address line 1  
Address line 2  
Address line 3  
Post Code

Vehicle Identification Number (VIN):  
Registration Number:  
Program Number: N908

Date: month/year

### **SAFETY RELATED RECALL - Defender, Discovery, Range Rover, Range Rover Sport and Range Rover Velar - Ingenium I6 3.0L Diesel and Petrol Oil Filter Cap - Renew**

Dear

JLR Limited would like to advise you that during ongoing quality assessment of our product it has been identified that a possible safety related problem may occur on certain JLR vehicles within a specific production range. Read the information below, this will explain the actions that we intend to take and what you will need to do.

#### **Why are we contacting you?**

A concern has been identified where the incorrect specification of plastic was used to manufacture the oil filter housing. The incorrect specification plastic housing will, over time and with vehicle use, crack allowing oil to leak out onto the engine and into the engine compartment.

An oil leak under pressure in this area could result in oil coming into contact with hot components on the engine which may result in a fire. Additionally, oil may leak onto the road surface posing a skid hazard to other road users especially two wheeled vehicles.

#### **What will your JLR retailer/authorized repairer do?**

At your visit, your preferred JLR retailer/authorized repairer will replace the oil filter housing and the oil filter element.

#### **How long will it take?**

The work on your vehicle will be completed as quickly and efficiently as possible in order to minimize inconvenience to you. Your JLR retailer/authorized repairer will be able to advise how long your vehicle will be required for when a booking is made.

#### **What we are asking you to do**

Contact your preferred JLR retailer/authorized repairer without delay. To book your vehicle in for this action you will need to provide the JLR retailer/authorized repairer with the following which are detailed at the beginning of this letter:

- The VIN for your vehicle
- Vehicle registration number of your vehicle.
- The program code for the action.

If you do not have a JLR retailer/authorized repairer, access, [www.landrover.co.uk](http://www.landrover.co.uk) or [www.landrover.com](http://www.landrover.com) for contact details.

If you no longer own the vehicle could you complete the 'Change of Ownership' slip attached to this letter, returning the slip to JLR Limited immediately in the enclosed 'Freepost' envelope. This will enable us to make contact with the new owner.

#### **If you have concerns**

If you experience any concerns relating to this Recall, contact the Service Manager at the JLR retailer/authorized repairer for assistance or contact the JLR Limited Customer Experience Centre on 0345 303 2303 or (enter phone number).

This campaign is being issued in accordance with the legislative or industry requirements concerning vehicle defects. The authorities will closely monitor the response rate of this campaign.

Treat this matter with the urgency it requires, JLR Limited apologize for any inconvenience this campaign may cause and thank you, in advance, for your co-operation.

Yours sincerely

Head of Business