



SAFETY RELATED RECALL

Global Recall Action
Number: [N908v6](#)

Changes are highlighted in blue

| | |
|-------------------------------------------------------------------------------------------------|-------------------------------|
| Subject: INGENIUM I6 3.0L Diesel and Petrol Oil Filter Element Cap - Renew | Publication No.: N908v6 |
| | Model: Defender (LE) |
| | Model Year: 2021 - 2025 |
| | Model: Discovery (LR) |
| | Model Year: 2021 - 2025 |
| | Model: Range Rover (LK) |
| | Model Year: 2023 - 2025 |
| | Model: Range Rover Sport (L1) |
| | Model Year: 2023 - 2025 |
| | Model: Range Rover Velar (LY) |
| | Model Year: 2024 - 2025 |
| | Model: Range Rover (LG) |
| | Model Year: 2021 |
| | Model: Range Rover Sport (LW) |
| Model Year: 2021 - 2022 | |
| Date of Issue: 25 November 2024 | |

| | |
|------------------------------|-------------------------------------------------------------------------------------------------------------------------------------------------------------------------------------------------------------------------------------------------------------------------------------------------------------------------------------------------------------------------------------------------------------------------------------------------------------------------------------------------------------------------------------------------------------------------------------------------------------------------------------------------------------------------------|
| To: | All National Sales Companies (NSCs), importers, retailers and authorized repairers. Jaguar Land Rover North America, LLC and Jaguar Land Rover Canada ULC. |
| For the Attention of: | The approved JLR retailer / authorized repairer. |
| Important: | <p>NOTE: The information in this campaign is intended for use by professional technicians. If you are not a JLR retailer / authorized repairer, do not assume that a condition described affects a specific vehicle. Contact an authorized JLR retailer / authorized repairer to determine if this campaign applies to a specific vehicle.</p> <p>This campaign supersedes Update Prior to Sale (UPS) UPS2924-1 with immediate effect. The blue highlighted text relates only to the date information. All text in this campaign should be read and understood in full.</p> <p>This campaign has been updated to add additional information into the Service Instruction.</p> |

FOR THE ATTENTION OF ALL:

DESCRIPTION OF ISSUE AND THE EFFECT ON VEHICLE OPERATION

A concern has been identified where the incorrect specification of plastic was used to manufacture the oil filter element cap. The incorrect specification plastic oil filter element cap will, over time and with vehicle use, crack allowing engine oil to leak out onto the engine and into the engine compartment.

An engine oil leak under pressure in this area could result in engine oil coming into contact with hot components on the engine which may result in a fire. Additionally, engine oil may leak onto the road surface posing a skid hazard to other road users especially two wheeled vehicles, and increase the risk of a crash.

ACTION TO BE TAKEN

JLR has taken the decision to recall affected vehicles to repair the vehicle.

Following procedures appropriate to your market and as required by local legislation, owners of affected vehicles should be contacted requesting that the owner contact their nearest JLR retailer / authorized repairer as soon as possible to arrange for the repair to be completed, (there may also be a PIVI message sent direct to the customer in addition). The National Sales Companies (NSCs), Importer, Regional Office or Government agency will contact the customers. If you have any questions about this process, contact your NSC/Importer or Regional Office for more information.

Check the JLR Warranty Portal to make sure affected vehicles are correctly identified prior to starting this campaign. The Warranty Portal will be updated to reflect only those vehicles affected.

JLR retailers / authorized repairers are reminded that they must not sell vehicles identified as affected by this campaign until such time as the repair has been successfully completed.

An owner may indicate that a repair has already been completed for this concern, in which case the full cost of the repair should be reimbursed. Refer to the warranty section of this campaign for details of the Customer Reimbursement and Related Damage Process. At the time of confirming a booking for a vehicle repair, make sure you check the Warranty Portal to confirm if there are any other outstanding campaigns, to make sure the correct parts are available and adequate workshop time is allocated for repairs to be completed in one visit.

For information purposes, a Technical Question and Answer document is attached.



The following applies to:
[NORTH AMERICA]

FOR THE ATTENTION OF NORTH AMERICAN TERRITORIES ONLY:



The following applies to:
[NORTH AMERICA]

National Highway Traffic Safety Administration (NHTSA) reference number: 24V-450



The following applies to:
[NORTH AMERICA]

Transport Canada (TC) reference number: 2024-352

Visit the British Brands Sales Suite (BBSS) website for a list of affected vehicles at your JLR retailer / authorized repairer. Unsold vehicles must be repaired prior to handover of the vehicle for retail sale.

REGULATORY INFORMATION



The following applies to:
[NORTH AMERICA]

Jaguar Land Rover North America, LLC and Jaguar Land Rover Canada ULC have informed the National Highway Traffic Safety Administration (NHTSA) and Transport Canada (TC) of their intent to perform a Safety Recall on certain Defender, Discovery, Range Rover, Range Rover Sport and Range Rover Velar 2023 model year and 2024 model year vehicles imported into the United States and Canadian markets. Information relating to this Safety Recall will be posted on the NHTSA and TC websites. United States Federal regulations require that JLR retailers / authorized repairers must be notified within a reasonable time after the manufacturer decides that a defect that relates to motor vehicle safety or a non-compliance exists. United States Federal Law requires JLR retailers / authorized repairers to complete any outstanding Safety Recall before a new vehicle is delivered to the buyer or lessee. Violation of this requirement by a JLR retailer / authorized repairer, in the USA only, could result in a maximum civil penalty of up to the equivalent of \$27,168.00 USD per violation and the equivalent of \$135,828,178.00 USD for a related series of violations. This Safety Recall serves as notification to all JLR retailers / authorized repairers in the United States and Federalized Territories and Canada that any affected new vehicles may not be sold and delivered for customer use until the Safety Recall repair is completed.



The following applies to:
[NORTH AMERICA]

Jaguar Land Rover North America, LLC and Jaguar Land Rover Canada ULC recommends that affected sales demonstrator and loaner vehicles are repaired before use, and that used vehicles are repaired before sale. JLR retailers / authorized repairers who proceed against this recommendation, where legally permitted, must clearly and conspicuously disclose the open Safety Recall notice to the applicable customers.

Yours faithfully

Steve Oldham

Global Customer Care Quality Director

SERVICE INSTRUCTION - N908V6

Changes are highlighted in blue

Parts Information

The parts below should be ordered through JLR in the normal manner.

| Description | Part Number | Qty |
|------------------------|-------------|-----|
| Oil filter element cap | LR133514 | 1 |
| Oil filter element | LR133455 | 1 |

SROs

| Description | SRO | Time |
|-----------------------------------------------------|----------|------|
| Oil filter element and oil filter element cap renew | 05.10.20 | 0.2 |
| Drive in/drive out | 02.02.02 | 0.2 |

NOTE:

Repair procedures are under constant review, and therefore times are subject to change; those quoted here must be taken as guidance only. Always refer to TOPIx to obtain the latest repair time.

Warranty Information

Warranty claims should be submitted quoting program code N908 with the relevant option code from the table below. As option codes are used there is no requirement for you to enter SROs or parts, these are included for information only.

Option codes **A** or **B** must only be claimed if the vehicle is repaired within the JLR retailer / authorized repairer workshop. For vehicles repaired away from the JLR retailer / authorized repairer workshop refer to the '**JLR Retailer Traveling Technician Repair**' section below.

| Program Code | Option | Description | SRO/Sundry code | Time | Part Number | Qty |
|--------------|--------|---------------------------------------------------------------------------|-----------------|------|-------------|-----|
| N908 | A | Oil filter element and oil filter element cap renew | 05.10.20 | 0.2 | LR133514 | 1 |
| | | | | | LR133455 | 1 |
| N908 | B | Oil filter element and oil filter element cap renew Drive in/drive out | 05.10.20 | 0.2 | LR133514 | 1 |
| | | | 02.02.02 | 0.2 | LR133455 | 1 |

JLR Retailer Traveling Technician Repair

JLR retailer / authorized repairer that select to travel to the customers location to complete the repair must claim the **RB** option code below.

NOTE:

*An allowance equivalent to £104.00 Sterling has been allocated for the JLR retailer traveling technician repair and is included in option code RB.

| Program Code | Option | Description | SRO/Sundry code | Time/Value (£) | Part Number | Qty |
|--------------|--------|------------------------------------------------------------------------------------------------|-----------------|----------------|-------------|-----|
| N908 | RB | JLR Retailer traveling technician repair - Oil filter element and oil filter element cap renew | 05.10.20 | 0.2 | LR133514 | 1 |
| | | | ZZZ999 | *£104 | LR133455 | 1 |

NOTE:

The option that contains the drive in/drive out allowance may only be claimed when the vehicle has been brought back into the workshop for this action alone to be undertaken.

Warranty claims should be submitted in accordance with the current JLR Global Warranty Manual, and its amendments, unless stated otherwise in this bulletin.

Customer Reimbursement and Related Damage Process

NOTE:

If there is a requirement to claim for related/consequential damage or customer reimbursement, refer to the related instruction that can be found in TOPIx (in the Search box, search for 'Related Damage Claim' and open the related bulletin link).

 NOTE:

The Touchscreen illustrations below show what will appear in the vehicle as a one time pop up.

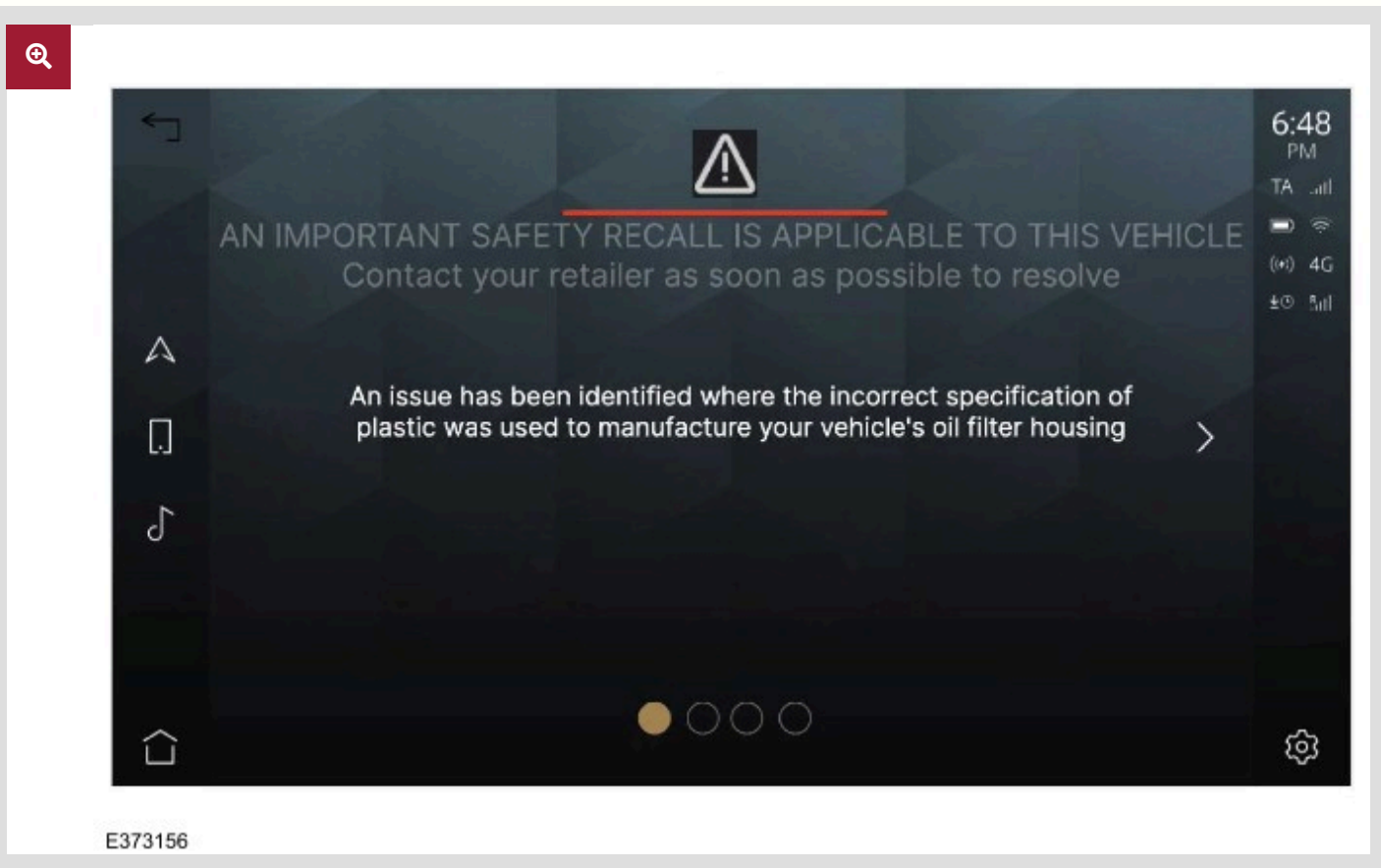

 NOTE:

Screen text may vary between markets but the core messaging and screen format will be consistent on all vehicles.



E373157



NOTE:

Screen text may vary between markets but the core messaging and screen format will be consistent on all vehicles.

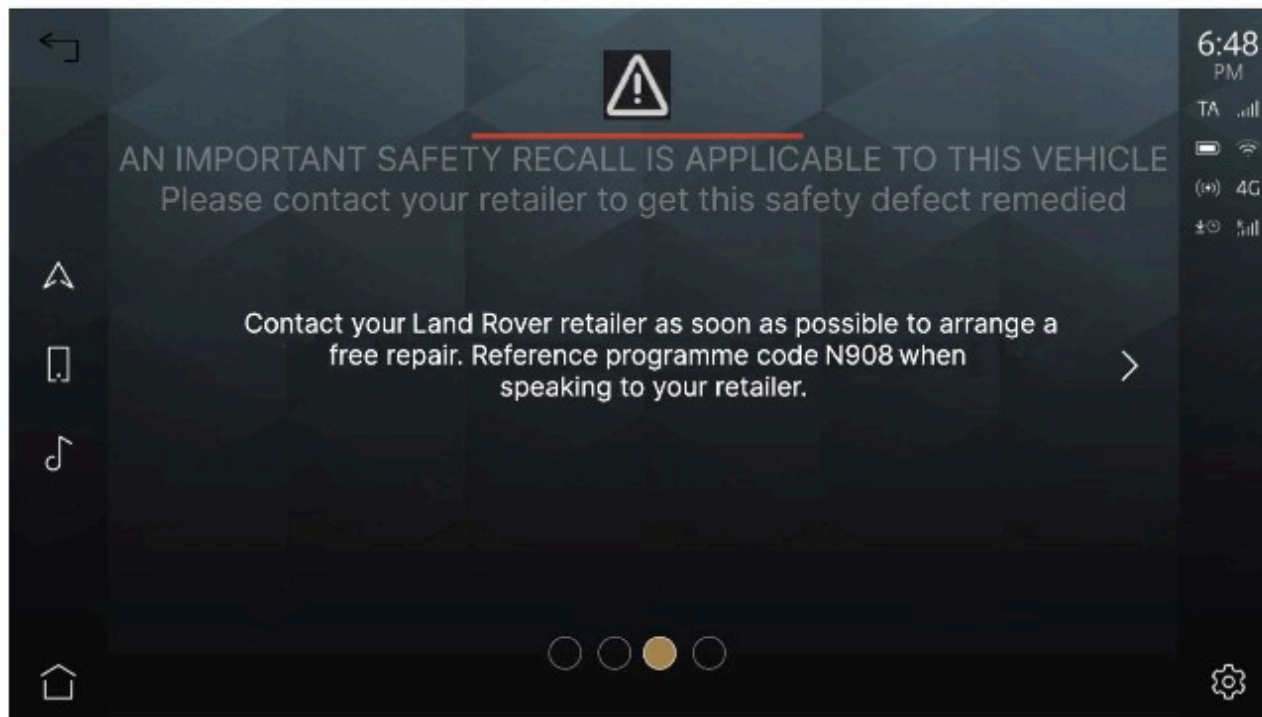

E373418



NOTE:

Screen text may vary between markets but the core messaging and screen format will be consistent on all vehicles.

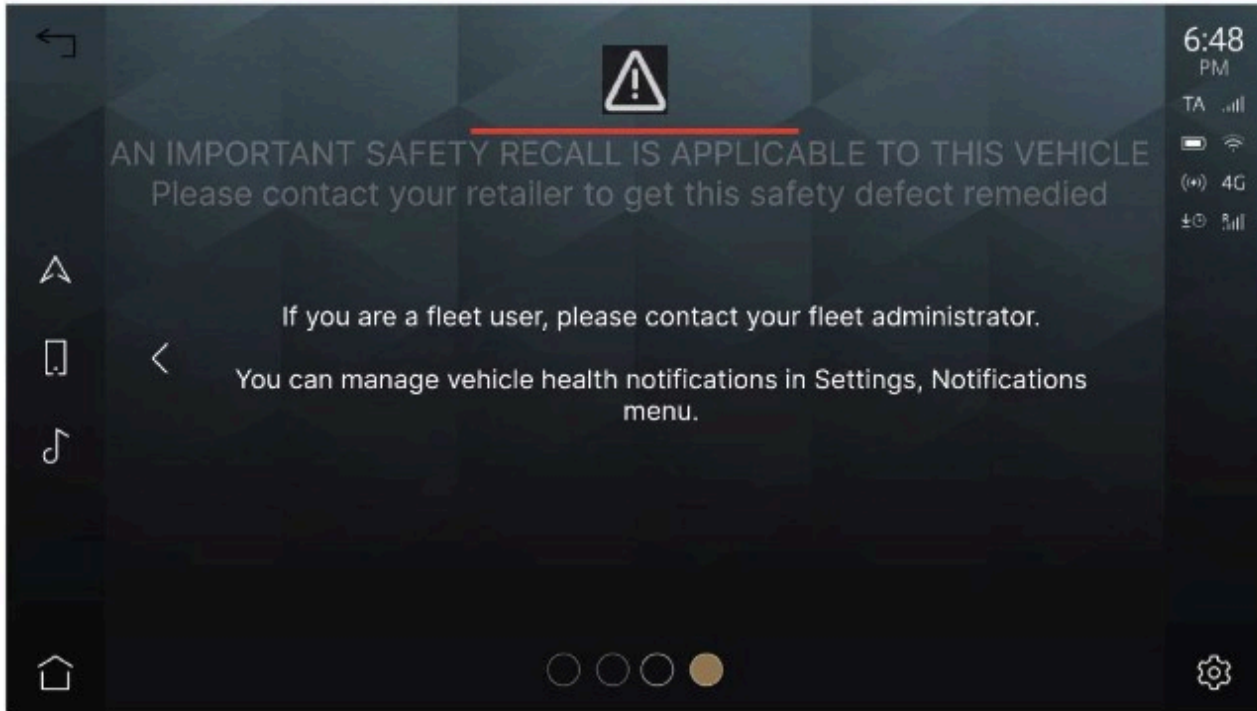

E373159



NOTE:

Screen text may vary between markets but the core messaging and screen format will be consistent on all vehicles.

SERVICE INSTRUCTION



The following applies to:
INGENIUM I6 3.0L Petrol

1. Remove the engine cover (see TOPIx Workshop Manual Section 501-05: Removal and Installation - Engine Cover - INGENIUM I6 3.0L Petrol).



The following applies to:
INGENIUM I6 3.0L Diesel

2. Remove the engine cover (see TOPIx Workshop Manual Section 501-05: Removal and Installation - Engine Cover - INGENIUM I6 3.0L Diesel).

3. If equipped, remove the Noise, Vibration and Harshness (NVH) cover.

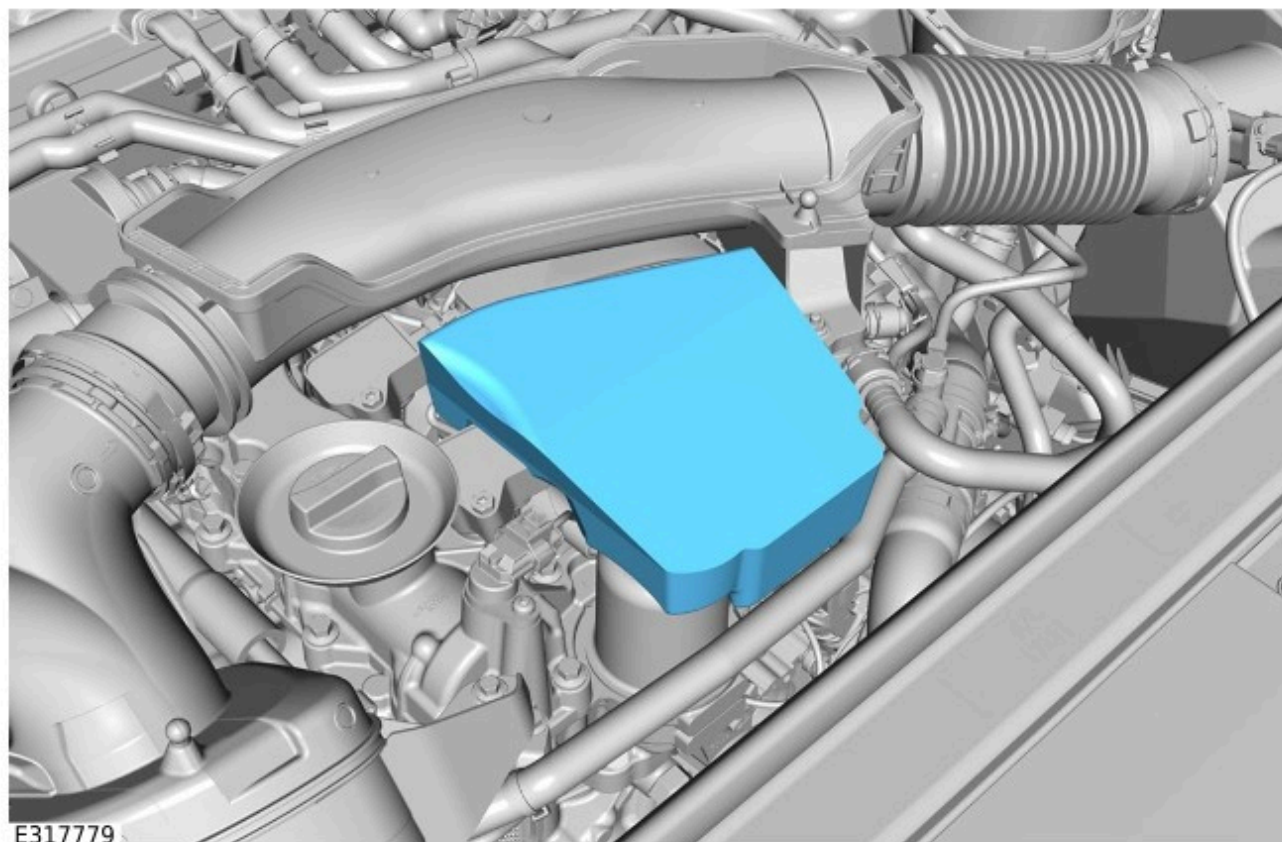

4. Loosen the oil filter element cap 4 complete turns.

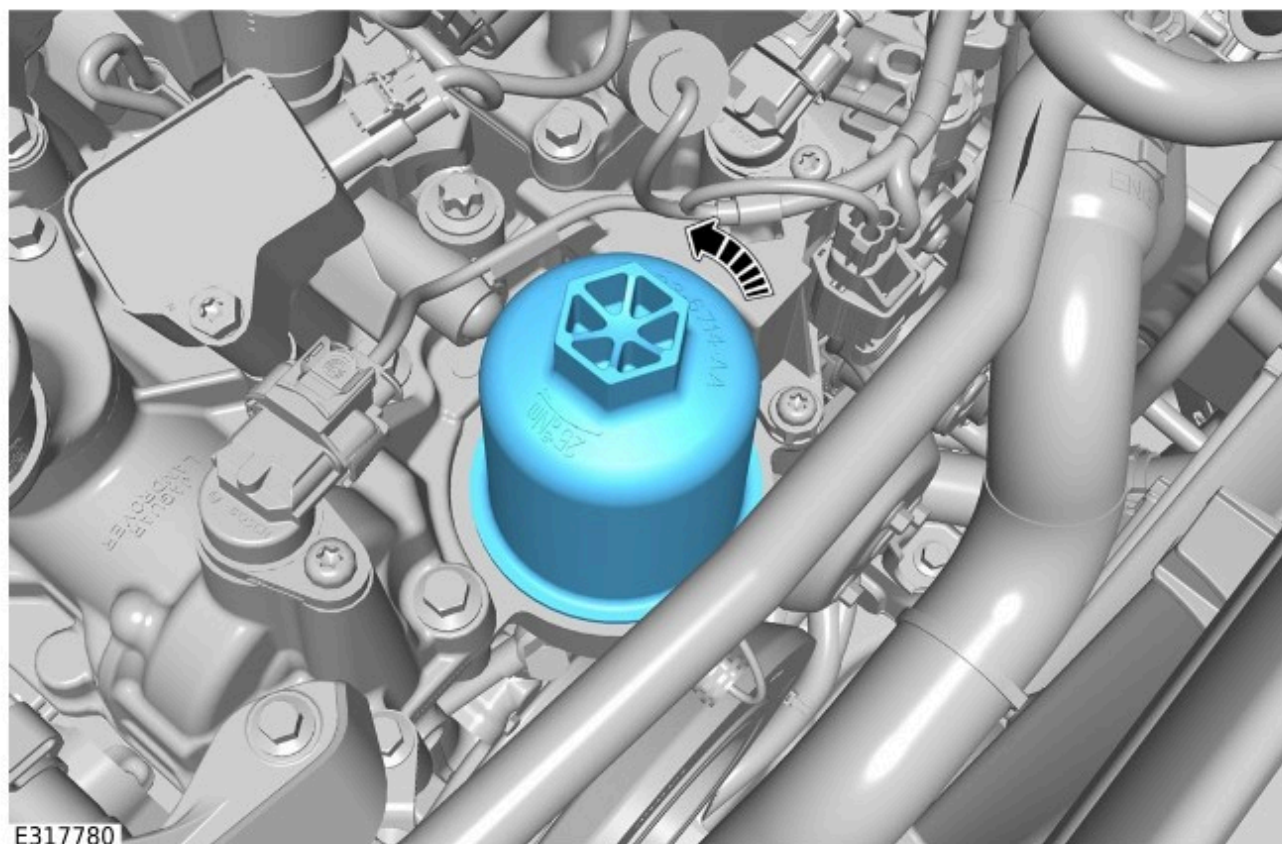

5. Remove and discard the oil filter element cap and the oil filter element.

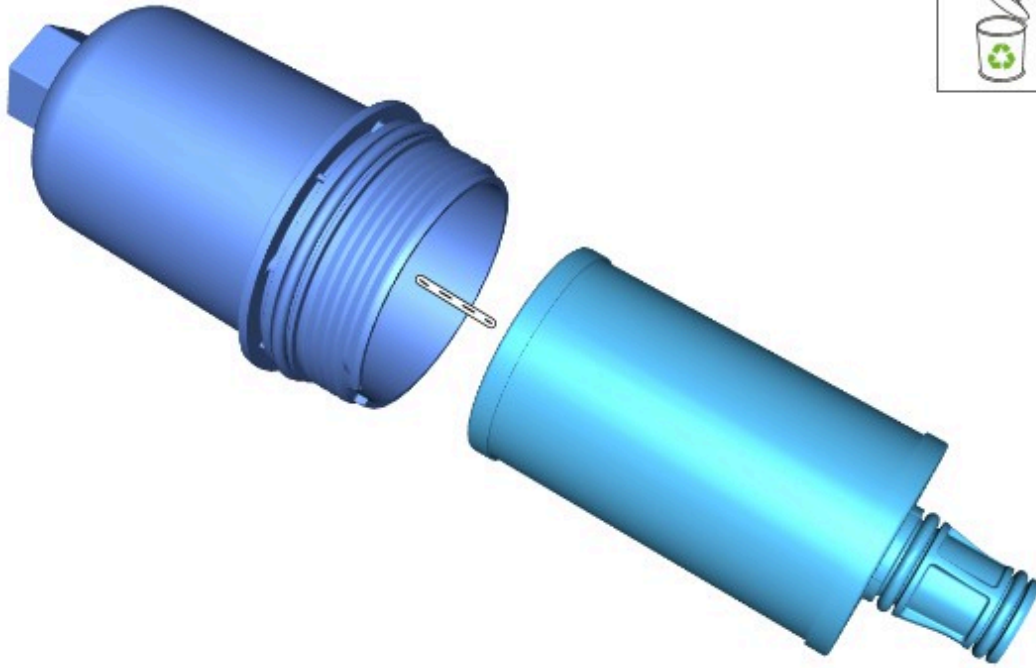

E363000

6. Install a new oil filter element. Make sure the oil filter element is pushed correctly onto the bypass valve inside the oil filter element cap (C).

- Lubricate the oil filter element cap O-ring (A) and oil filter element O-ring (B) with clean engine oil.

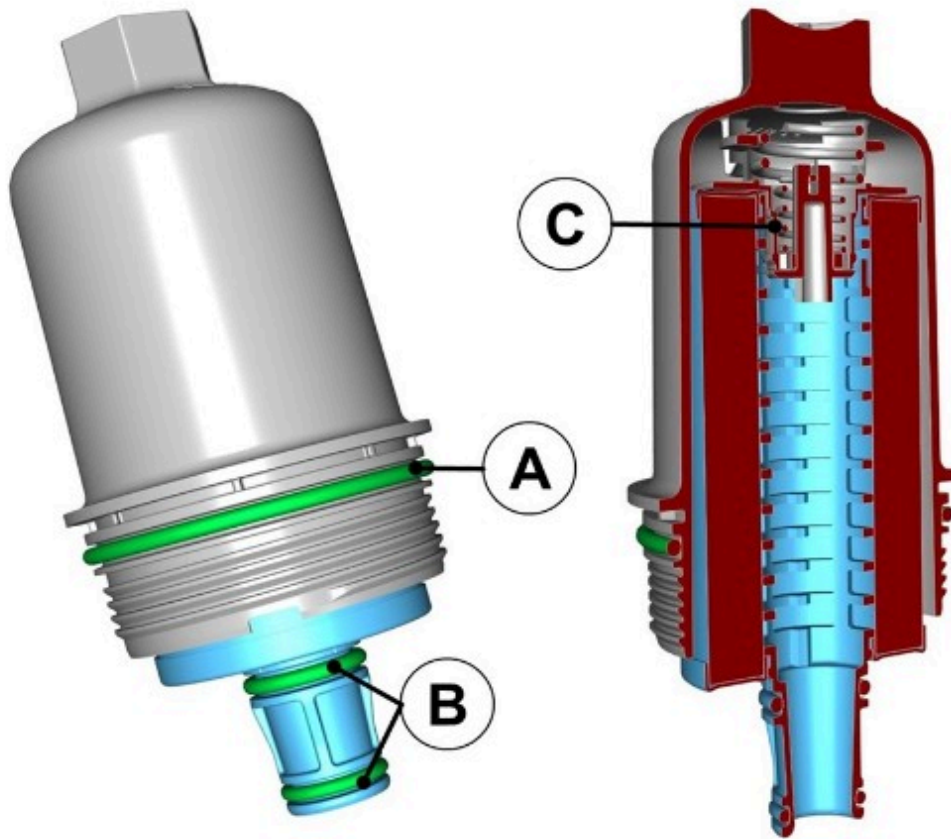

E317783

7. Install and tighten the new oil filter element cap.

- Torque: **25 Nm**

8. Start the engine and allow to idle for 2 minutes.

- Check for leaks.
- Stop the engine.

9. If equipped, install the [NVH](#) cover.

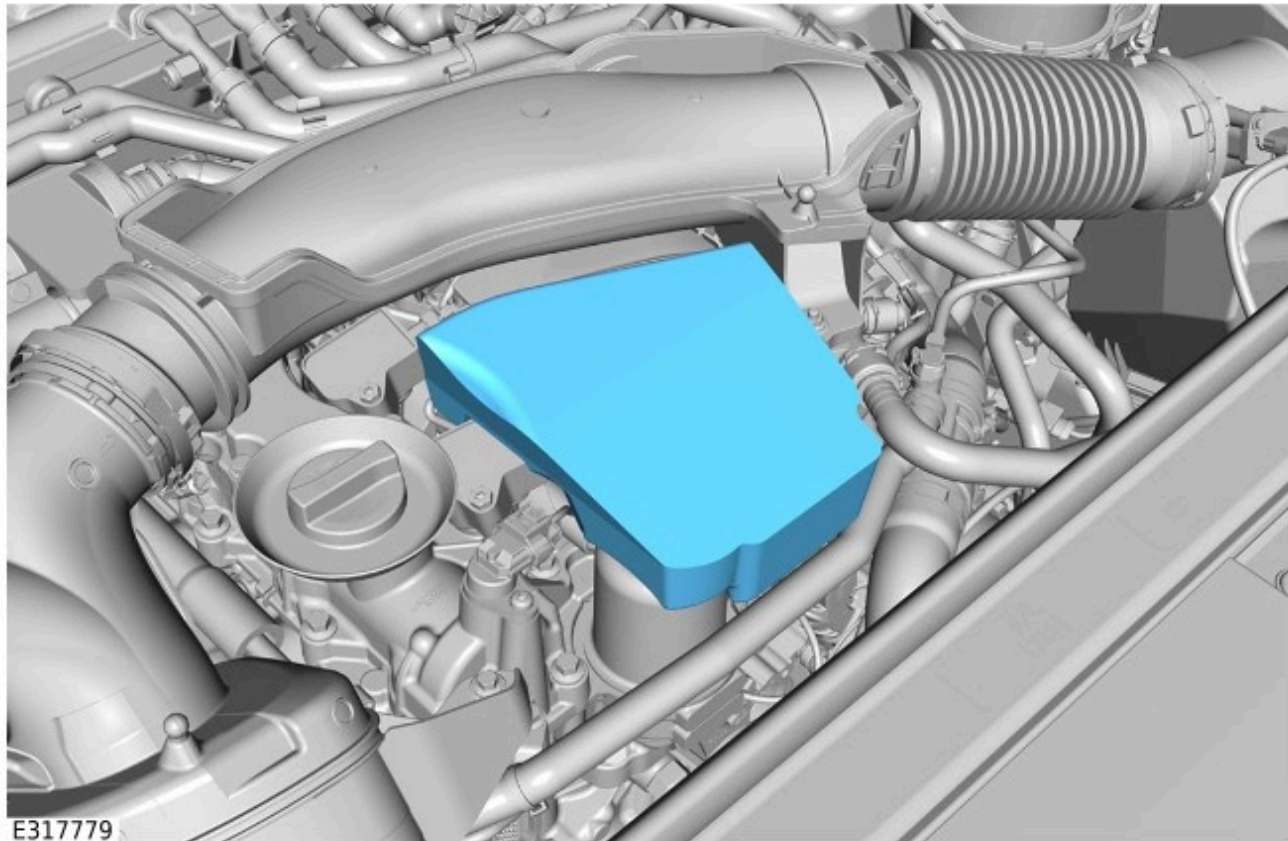

The following applies to:
INGENIUM I6 3.0L Petrol

10. Install the engine cover (see TOPIx Workshop Manual Section 501-05: Removal and Installation - Engine Cover - INGENIUM I6 3.0L Petrol).



The following applies to:
INGENIUM I6 3.0L Diesel

11. Install the engine cover (see TOPIx Workshop Manual Section 501-05: Removal and Installation - Engine Cover - INGENIUM I6 3.0L Diesel).

SAMPLE CUSTOMER LETTER - FOR INFORMATION ONLY

Name
Address line 1
Address line 2
Address line 3
Post Code

Vehicle Identification Number (VIN):
Registration Number:
Program Number: N908

Date: month/year

SAFETY RELATED RECALL - Defender, Discovery, Range Rover, Range Rover Sport and Range Rover Velar - INGENIUM I6 3.0L Diesel and Petrol Oil Filter Element Cap - Renew

Dear

JLR Limited would like to advise you that during ongoing quality assessment of our product it has been identified that a possible safety related problem may occur on certain JLR vehicles within a specific production range. Read the information below, this will explain the actions that we intend to take and what you will need to do.

Why are we contacting you?

A concern has been identified where the incorrect specification of plastic was used to manufacture the oil filter element cap. The incorrect specification plastic oil filter element cap will, over time and with vehicle use, crack allowing engine oil to leak out onto the engine and into the engine compartment.

An engine oil leak under pressure in this area could result in engine oil coming into contact with hot components on the engine which may result in a fire. Additionally, engine oil may leak onto the road surface posing a skid hazard to other road users especially two wheeled vehicles, and increase the risk of a crash.

What will your JLR retailer / authorized repairer do?

At your visit, your preferred JLR retailer / authorized repairer will replace the oil filter element and the oil filter element cap.

How long will it take?

The work on your vehicle will be completed as quickly and efficiently as possible in order to minimize inconvenience to you. Your JLR retailer / authorized repairer will be able to advise how long your vehicle will be required for when a booking is made.

What we are asking you to do

Contact your preferred JLR retailer / authorized repairer without delay. To book your vehicle in for this action you will need to provide the JLR retailer / authorized repairer with the following which are detailed at the beginning of this letter:

- The VIN for your vehicle
- Vehicle registration number of your vehicle.
- The program code for the action.

If you do not have a JLR retailer / authorized repairer, access, www.landrover.co.uk or www.landrover.com for contact details.

If you no longer own the vehicle could you complete the 'Change of Ownership' slip attached to this letter, returning the slip to JLR Limited immediately in the enclosed 'Freepost' envelope. This will enable us to make contact with the new owner.

If you have concerns

If you experience any concerns relating to this Recall, contact the Service Manager at the JLR retailer / authorized repairer for assistance or contact the JLR Limited Customer Experience Centre on 0345 303 2303 or (enter phone number).

This campaign is being issued in accordance with the legislative or industry requirements concerning vehicle defects. The authorities will closely monitor the response rate of this campaign.

Treat this matter with the urgency it requires, JLR Limited apologize for any inconvenience this campaign may cause and thank you, in advance, for your co-operation.

Yours sincerely

Head of Business

Technical Questions And Answers



FOR USE ON ENQUIRY

JLR Recall N908

INGENIUM I6 3.0L Diesel and Petrol Oil Filter Element Cap - Renew

A concern has been identified where the incorrect specification of plastic was used to manufacture the oil filter element cap. The incorrect specification plastic oil filter element cap will, over time and with vehicle use, crack allowing engine oil to leak out onto the engine and into the engine compartment.

Question 1

Who do I contact if a member of the press contacts me about this recall?

Answer

Make sure that any press enquiries are referred to the JLR Corporate Affairs office.

Question 2

Why is JLR recalling certain models?

Answer

JLR is conducting a safety recall of certain 2021 model year to 2025 model year INGENIUM I6 3.0L Diesel and Petrol vehicles due to an issue with the specification of plastic used by a supplier in the manufacture of the oil filter element cap. The oil filter element cap may crack leading to the risk of a fire.

Question 3

Can you tell me more about what is wrong with the vehicles?

Answer

Assessment of the consequences of the cracking and experiences from field reports is that the crack allows engine oil to leak out. The engine oil is under normal oil system pressure, (nominally 5 bar (72.5psi)) and can get onto hot engine components such as turbochargers and exhaust manifolds. It is possible that an engine compartment fire can start which could lead to a more significant vehicle fire. Also, engine oil can leak onto the road surface leading to a skid hazard for following vehicles especially two wheeled vehicles, and increase the risk of a crash.

Question 4

How would the customer become aware of potentially having this concern?

Answer

Smoke and potentially flames may be seen from the engine compartment area. Also, there may be signs of oil staining on drives and in parking bays.

Question 5

Does this concern affect vehicle safety?

Answer

Yes this affects vehicle safety due to the risk of a fire developing.

Question 6

Has JLR received many complaints?

Answer

Yes, JLR has received a number of reports of this concern and a small number of reports of vehicle fires.

Question 7

Have there been any accidents or injuries or fires?

Answer

There have been a small number of reports of fires attributed to this concern. Failures are presently most predominant on the non-Plug-in Hybrid Electric Vehicle (PHEV) Petrol (gasoline) variant.

Question 8

How was the condition discovered?

Answer

This issue was discovered through JLR's field reporting system and reported by JLR retailers / authorized repairers.

Question 9

How long has JLR known about this problem?

Answer

This issue was recognized as a safety issue on 13 June 2024.

Question 10

Is the defect leading you to any concerns regarding the reliability of the vehicle?

Answer

JLR has no concerns with the overall reliability of the vehicle. JLR carefully monitors field data to make sure that any matters relating to safety and compliance are rigorously investigated

Question 11

What has JLR done in production?

Answer

The supplier of the oil filter element cap has put in place checks to make sure only the correct specification plastic is used.

Question 12

What will JLR retailers / authorized repairers do to the vehicles?

Answer

The repair is to replace the oil filter element and oil filter element cap. This repair can be completed without the need for dedicated work bays and specialist tools and equipment but needs to be completed by a suitably qualified person.

Question 13

Which vehicles are affected by this recall?

Answer

This issue affects certain 2021 model year to 2025 model year, INGENIUM I6 3.0L Diesel and Petrol, Defender, Discovery, Range Rover, Range Rover Sport and Ranger Rover Velar vehicles.

Question 14

Are other JLR models affected by these actions?

Answer

Yes, 2024 model year F-PACE vehicles.

Question 15

Are parts available to rework vehicles?

Answer

Parts are being urgently distributed to markets to allow this recall repair to be completed as soon as possible.

Question 16

How much will the recall cost JLR?

Answer

Cost was not a factor in deciding to recall these vehicles.

Question 17

How do I know if my vehicle is affected?

Answer

All owners of potentially affected vehicles will shortly be contacted and invited to have the work completed. Customers are requested to have the repair completed as soon as possible. Where vehicles have covered 3000 miles (4800 km) or more, it is imperative that the repairs are completed without delay as the risk of the oil filter element cap cracking is greater at distances in excess of 3000 miles (4800 km).

In some countries, recall information is available online through the Jaguar or Land Rover brand web site.

Also, Customers can use the Recall Search at <https://TOPIx.jaguar.jlrext.com/TOPIx/vehicle/lookupForm>

Question 18

How long does it take for the vehicle to be inspected and repaired?

Answer

The work will be completed out as quickly and efficiently as possible and is being treated as the number one priority for JLR retailers / authorized repairers.

Question 19

Can I continue to drive my vehicle safely until it has been recalled?

Answer

Given the severity of failure, and for especially for non-PHEV Petrol vehicles it is vital that the repair is completed without delay. Customers are requested to be extra vigilant for the presence of smoke from the hood area and also for any oil from the underside of the vehicle likely seen by oil stains on driveways or parking bays.

Note:

Make sure that any press enquiries are referred to the JLR Corporate Media office on +44-(0)2475-361000 or jlmedia@jaguarlandover.com