

TECHNICAL INSTRUCTIONS
FOR
SAFETY RECALL 24TA08
Backup Camera Image May Not Display
CERTAIN 2023 CROWN

Updated

8.27.2024 – Added Rear Camera only Replacement (PVM Vehicles)

8.16.2024 – Application Download Instructions

The repair quality of covered vehicles is extremely important to Toyota. All dealership technicians performing this Recall are required to successfully complete the most current version of the E-Learning course “Safety Recall and Service Campaign Essentials”. To ensure that all vehicles have the repair performed correctly; technicians performing this Recall repair are required to currently hold at least one of the following certification levels:

-TIC206A – Electrical repair 1

It is the dealership’s responsibility to select technicians with the above certification level or greater to perform this Recall repair. Carefully review your resources, the technician skill level, and ability before assigning technicians to this repair. It is important to consider technician days off and vacation schedules to ensure there are properly trained technicians available to perform this repair at all times.

I. OPERATION FLOW CHART

The flow chart is for reference only. **DO NOT** use it in place of the full technical instructions. Follow **ALL** steps as outlined in the full technical instructions to confirm the campaign is completed correctly.

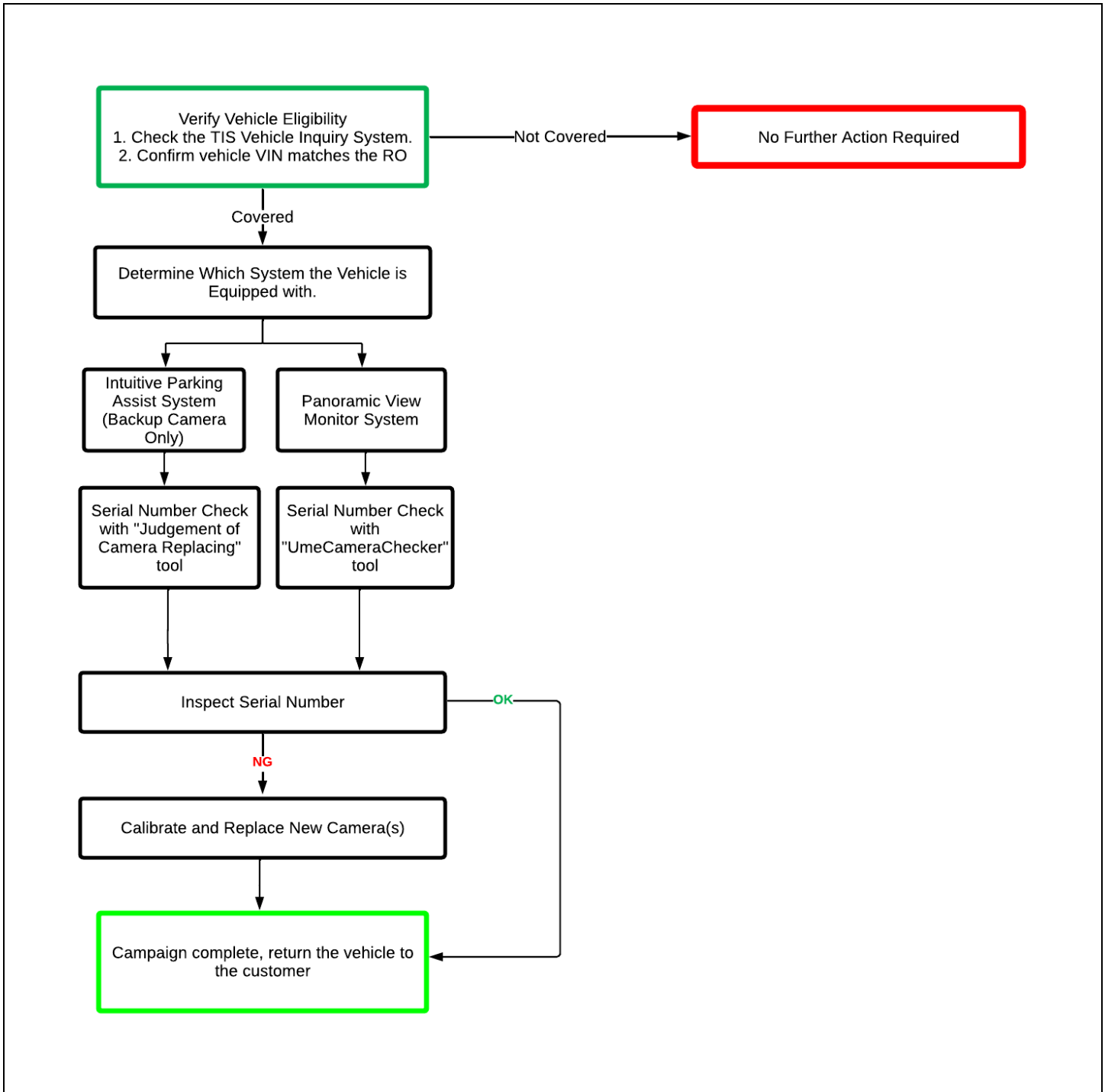

II. IDENTIFICATION OF AFFECTED VEHICLES

1. CHECK VEHICLE FOR CAMPAIGN ELIGIBILITY

- Compare the vehicle's VIN to the VIN listed on the Repair Order to ensure they match.
- Check the TIS Vehicle Inquiry System to confirm the VIN is involved in this Campaign, and that it has not already been completed.

NOTICE:

TMNA warranty will not reimburse dealers for repairs completed on vehicles that are not affected or were previously completed, even by another dealer.

III. PREPARATION

A. PARTS

Not all vehicles will require part replacement.

Part Number	Part Description	Quantity	Remarks
04003-66130	CAMERA ASSY, TELEVISION*	1	Front camera
Part Number	Part Description	Quantity	Remarks
04003-63730	CAMERA ASSY, TELEVISION*	1	Rear camera for Vehicle w/ Panoramic View Monitor System
Part Number	Part Description	Quantity	Remarks
04003-63930	CAMERA ASSY, TV W/DYNAMIC GUIDE LINE*	1	Rear camera for w/ Parking Assist Monitor System (Back up Camera Only)
Part Number	Part Description	Quantity	Remarks
04003-73630	PACKING, RR LAMP*	1	Necessary parts when replacing rear camera

B. TOOLS, SUPPLIES & EQUIPMENT

For Panoramic View Monitor

SET, PVM TOOL



- UmeCameraChecker
- Torque wrench
- PC or ADVi

If replacing a rear camera and or front Camera:

- GTS+
- Torque Wrench
- Molding Removal Tool



Camera Adjustment:

[Vehicle w/ Panoramic View Monitor System]

- Clean Cardboard
- String
- Tape Measure
- 90-degree Angled Wooden Block or Bookend
- Weight with String

TARGET SHEET & MARKER SHEET

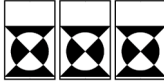
(SST:09870-52010,09870-52020 can be used in place of Target and Marker sheet.)

SET, TARGET SHEET	SET, MARKER SHEET
	

MATERIALS

- Protective Tape
- Marker Pen
- Tape
- Glue

For Rear Parking Assist Monitor (Back Up Camera Only)

Target Bar for Back Camera Adjustment
GTS+

Judgement of Camera zip

IV. WORK PROCEDURE TABLE OF CONTENTS

BACKGROUND.....SECTION V.
 SERIAL NUMBER CHECKSECTION VI.
 CHECK TELEVISION CAMERA ASSEMBLY SERIAL NUMBER
 (VEHICLES W/ PANORAMIC VIEW MONITOR SYSTEM)SECTION VII.
 CHECK TELEVISION CAMERA ASSEMBLY SERIAL NUMBER
 (VEHICLES W/ PARKING ASSIST MONITOR SYSTEM).....SECTION VIII.
 REPLACE TELEVISION CAMERA ASSEMBLYSECTION IX.
 PLACEMENT OF MARKER SHEET AND TARGETSECTION X.
 CAMERA ADJUSTMENT (VEHICLES W/ PANORAMIC VIEW MONITOR SYSTEM)SECTION XI.
 CAMERA ADJUSTMENT (VEHICLES W/ PARKING ASSIST MONITOR SYSTEM)SECTION XII.

V. BACKGROUND

Panoramic View Monitor System

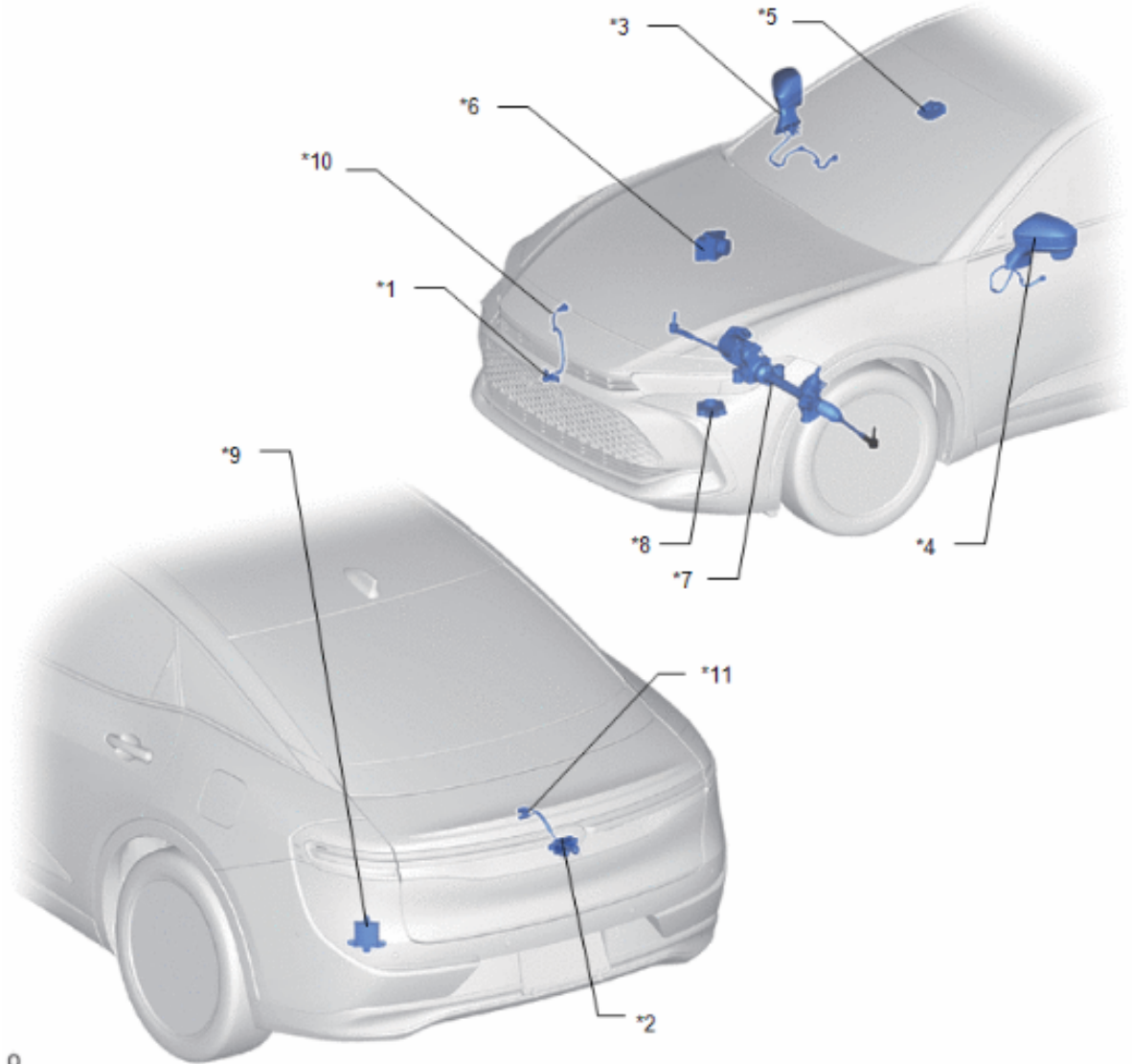

*1	FRONT TELEVISION CAMERA ASSEMBLY	*2	REAR TELEVISION CAMERA ASSEMBLY
*3	OUTER REAR VIEW MIRROR ASSEMBLY RH - PARKING ASSIST LIGHT RH - SIDE TELEVISION CAMERA ASSEMBLY RH	*4	OUTER REAR VIEW MIRROR ASSEMBLY LH - PARKING ASSIST LIGHT LH - SIDE TELEVISION CAMERA ASSEMBLY LH
*5	FORWARD RECOGNITION CAMERA	*6	BRAKE ACTUATOR ASSEMBLY (NO. 2 SKID CONTROL ECU)
*7	RACK AND PINION POWER STEERING GEAR ASSEMBLY - POWER STEERING ECU	*8	HEADLIGHT ECU SUB-ASSEMBLY LH
*9	BLIND SPOT MONITOR SENSOR LH (B)	*10	FRONT TELEVISION CAMERA WIRE
*11	REAR TELEVISION CAMERA WIRE	-	-

Intuitive Parking Assist System

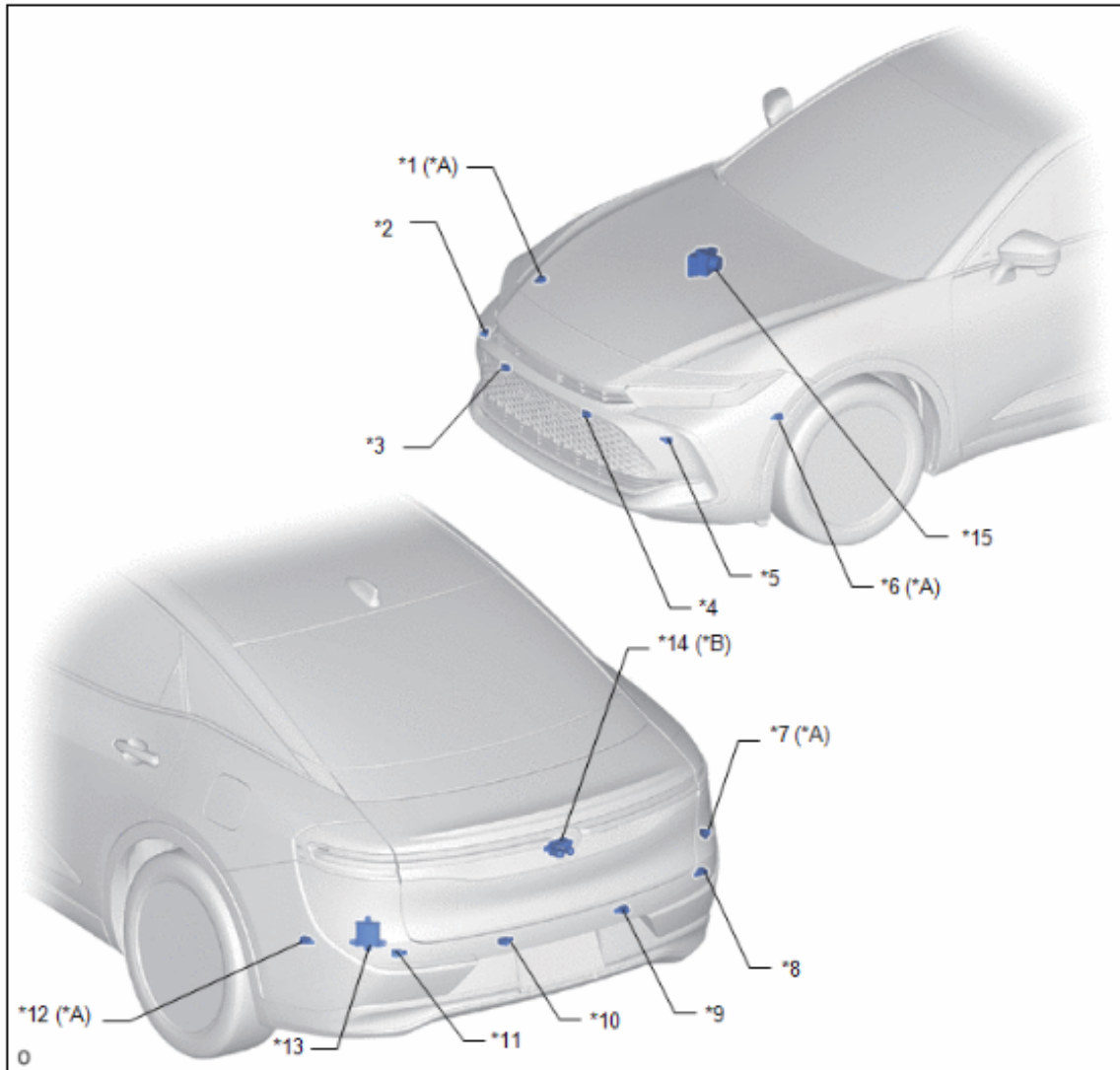

*A	w/ Advanced Park	*B	w/ Parking Assist Monitor System
*1	FRONT SIDE ULTRASONIC SENSOR (FRS SENSOR)	*2	FRONT CORNER ULTRASONIC SENSOR (FR SENSOR)
*3	FRONT CENTER ULTRASONIC SENSOR (FRC SENSOR)	*4	FRONT CENTER ULTRASONIC SENSOR (FLC SENSOR)
*5	FRONT CORNER ULTRASONIC SENSOR (FL SENSOR)	*6	FRONT SIDE ULTRASONIC SENSOR (FLS SENSOR)
*7	REAR SIDE ULTRASONIC SENSOR (RRS SENSOR)	*8	REAR CORNER ULTRASONIC SENSOR (RR SENSOR)
*9	REAR CENTER ULTRASONIC SENSOR (RRC SENSOR)	*10	REAR CENTER ULTRASONIC SENSOR (RLC SENSOR)
*11	REAR CORNER ULTRASONIC SENSOR (RL SENSOR)	*12	REAR SIDE ULTRASONIC SENSOR (RLS SENSOR)
*13	BLIND SPOT MONITOR SENSOR LH (B)	*14	REAR TELEVISION CAMERA ASSEMBLY
*15	BRAKE ACTUATOR ASSEMBLY (NO. 2 SKID CONTROL ECU)	-	-

HINT:
The illustration shown is an example.

VI. SERIAL NUMBER CHECK

1. INSPECT VEHICLE FOR CAMERA TYPE.

- If the vehicle has a front camera it is equipped with a Panoramic View Monitor System
- If the vehicle only has a backup camera it is equipped with an Intuitive Parking Assist System.

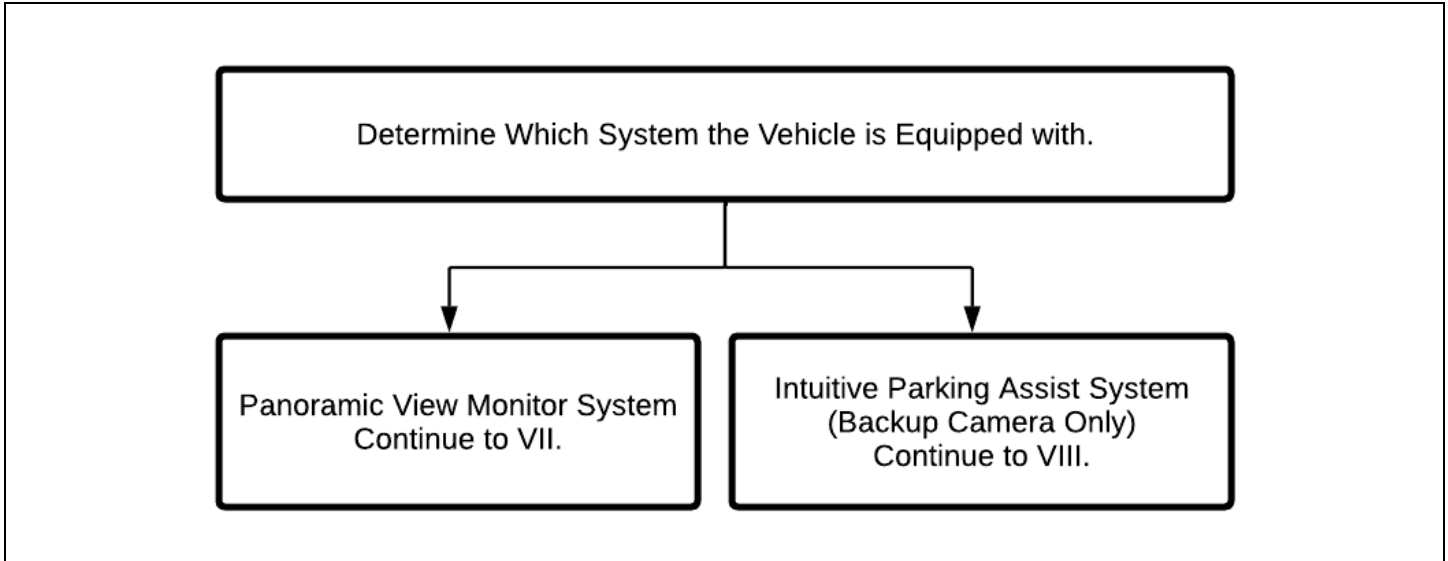

VII. Inspect Serial Number – Intuitive Parking Assist System

1. PREPARE VEHICLE FOR CAMERA INSPECTION (VEHICLES W/ PANORAMIC VIEW MONITOR SYSTEM)

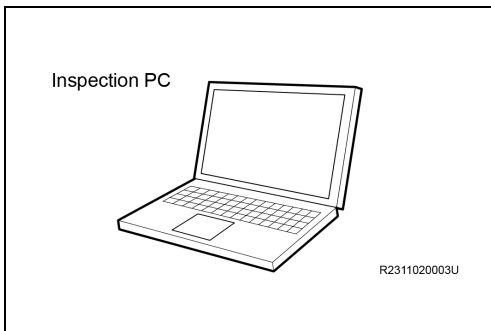

2. PREPARATION OF INSPECTION TOOL

- Prepare the ADVi or PC.

Spec Required:

- Windows10 (64bit Pro / Enterprise)
- USB2.0 (TYPE-A) 2 ports or more

Note: Do not disconnect the battery during this inspection. Perform removal and installation with the ignition switch in the OFF position and ensure the ignition switch is NEVER turned to the ON position for the duration of this work procedure.

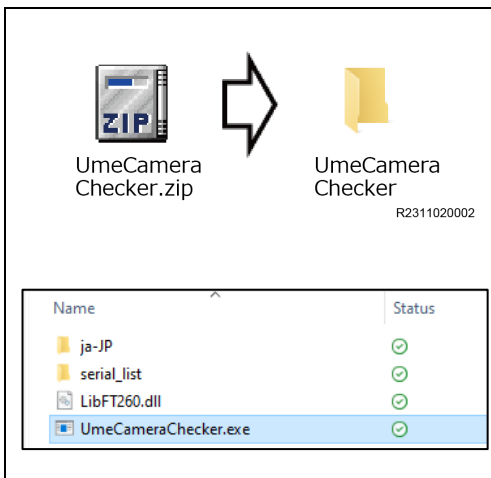

3. DOWNLOAD THE INSPECTION TOOL

- Download file **HERE** and save to the desktop.

File name: UmeCameraChecker.zip

- Unzip and extract the downloaded ZIP file and check that each file is created.

- This tool will be used in a later step.

Note: **DO NOT** delete the files inside the folder.

4. CONFIRM INSPECTION TOOL HAS ALL CORDS

- a) The package will include the SST and 2 Micro USB cables.



5. MOVE PASSENGER SEAT ALL THE WAY BACK

- a) Once the seat is in the furthest back position the front No. 2 Console box insert will be accessible.



6. REMOVE FRONT NO. 2 CONSOLE BOX INSERT

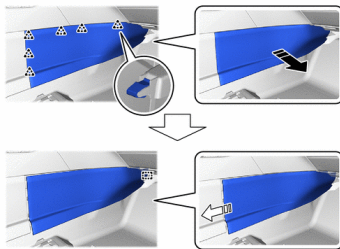

7. DISCONNECT THE 4 CONNECTORS FROM THE PARKING ASSIST ECU

- a) Push on the tab at the top of the connector and pull back to release each connector from the parking assist ECU.
 - b) Plug the SST connectors into the appropriate positions in the parking assist ECU
- Hint: The blue connector does not need to be unplugged.

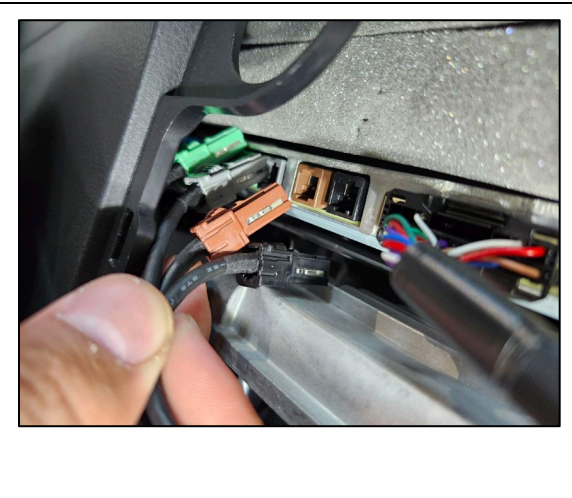
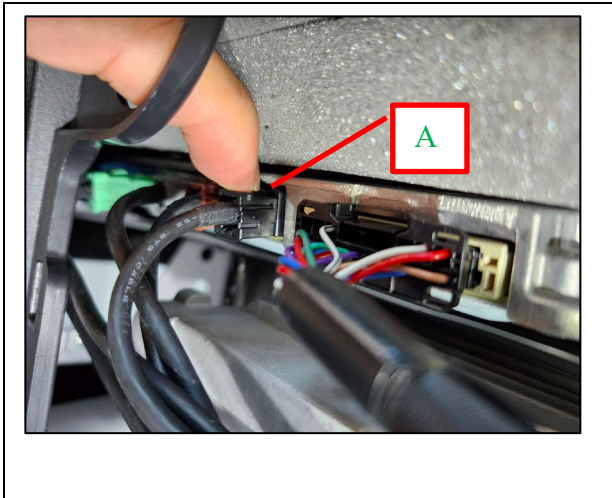
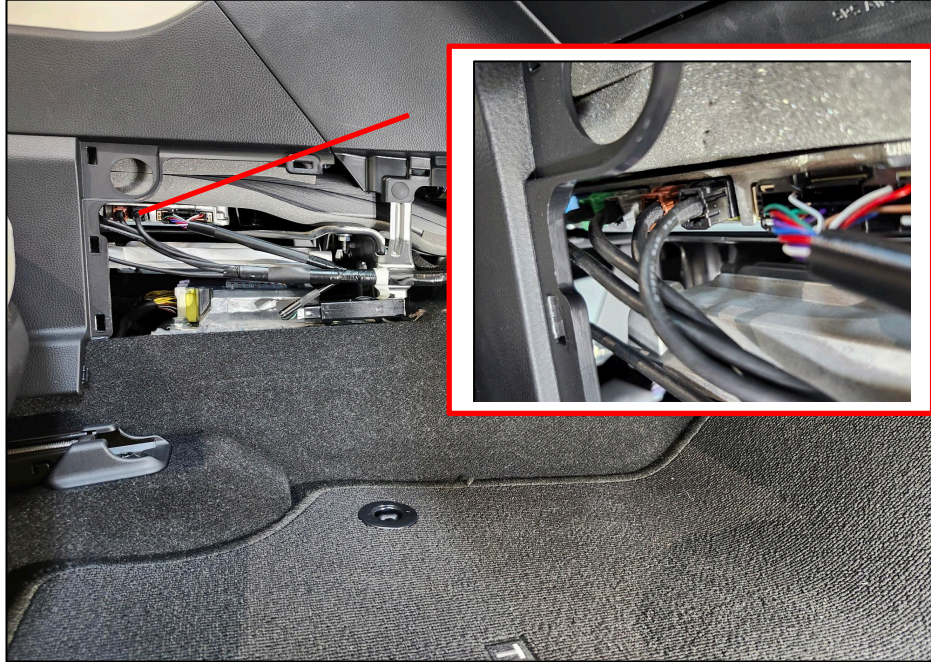

8. CONNECT THE 2 SST MICRO USB CABLES TO THE PC



9. CONNECT THE 2 SST MICRO USB CABLES TO THE SST

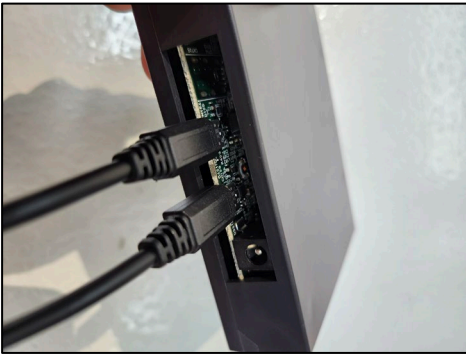

10. CONNECT THE 4 CONNECTORS FROM THE ECU HARNESS TO THE SST

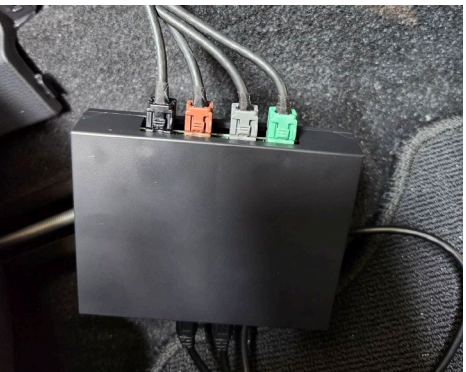

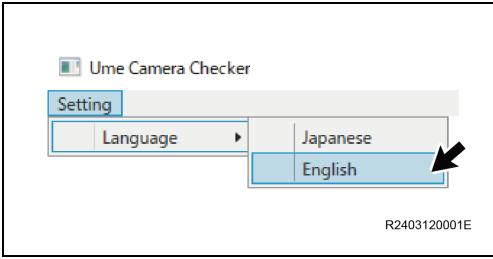

11. SERIAL NUMBER CHECK

- a) Close any running software such as GTS+.
- b) Launch "UmeCameraChecker.exe".
- c) Select language. (First time only).

12. SERIAL NUMBER CHECK

- c) Enter VIN.
- d) Select log save location and save to desktop.

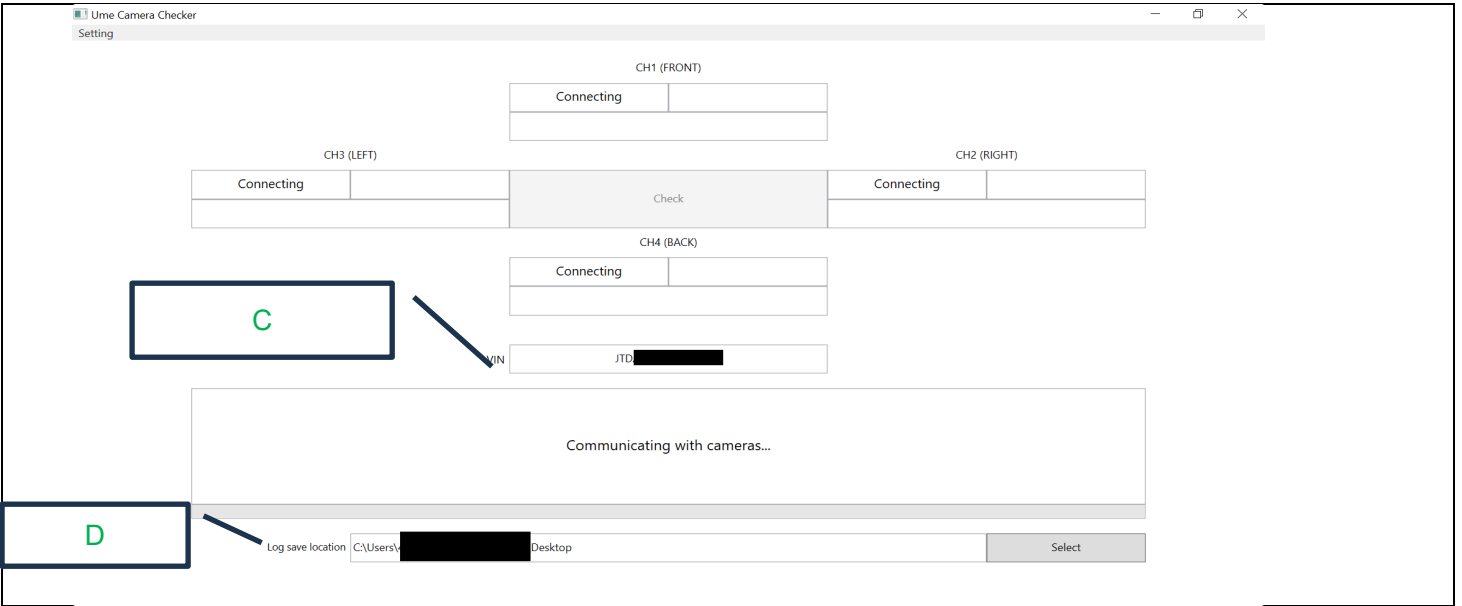

13. RUN VIN CHECK

- a) Click "Check"

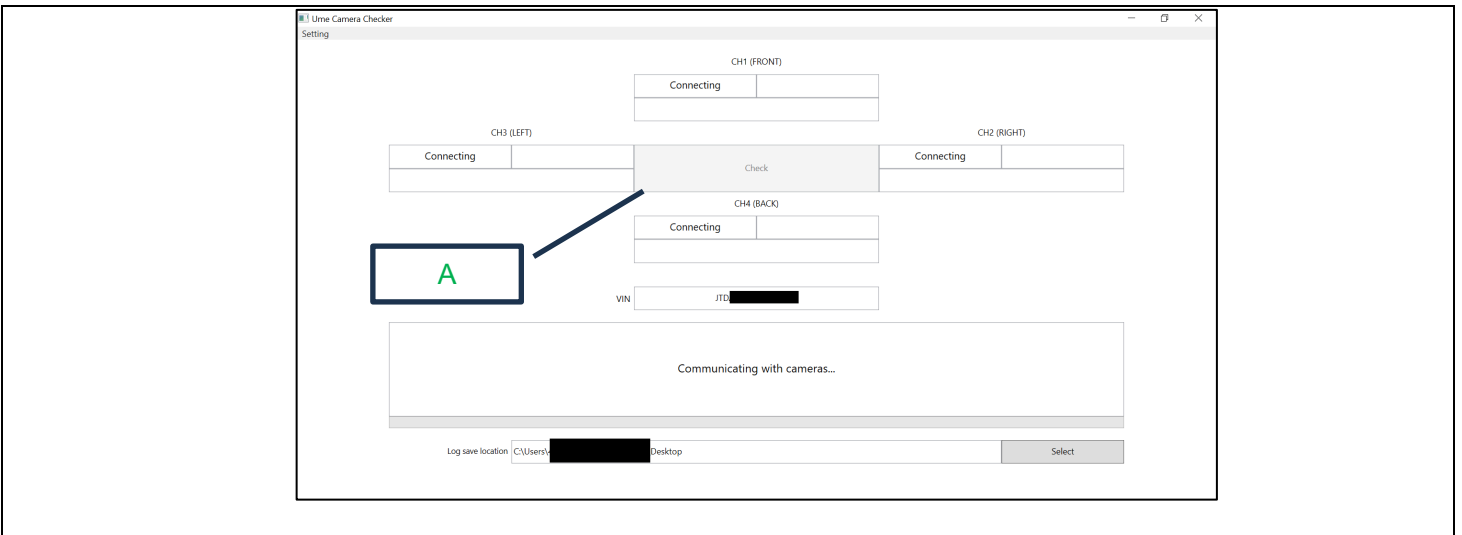

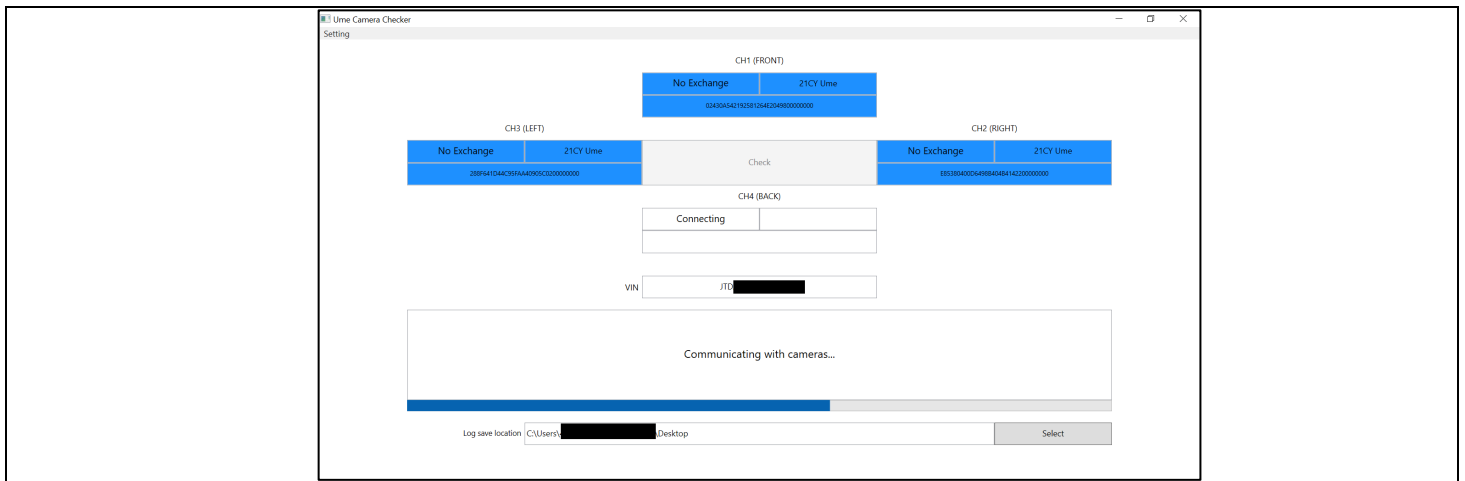

14. CONFIRM SERIAL NUMBER CHECK RESULTS

Result		Action				
NG	<table border="1"> <tr> <td>Exchange</td> <td>21CY Ume</td> </tr> <tr> <td colspan="2">5F9AA30042E151272436242000000000</td> </tr> </table>	Exchange	21CY Ume	5F9AA30042E151272436242000000000		Replacement of the camera(s) is REQUIRED . ↓ Complete inspection and replace the camera(s) with a new one. Continue to step IX. Step 1 .
	Exchange	21CY Ume				
5F9AA30042E151272436242000000000						
OK	<table border="1"> <tr> <td>No Exchange</td> <td>21CY Ume</td> </tr> <tr> <td colspan="2">8014565A90A81030E4747D1000000000</td> </tr> </table>	No Exchange	21CY Ume	8014565A90A81030E4747D1000000000		Replacement of cameras is NOT REQUIRED ↓ Continue to Step 15
No Exchange	21CY Ume					
8014565A90A81030E4747D1000000000						
	The result shown below is displayed for the camera under inspection. <table border="1"> <tr> <td>Error</td> <td>Unknown</td> </tr> </table>	Error	Unknown	Camera communication failure ↓ Check the connection of USB and cameras and retry the inspection.		
Error	Unknown					

15. COMPLETE STEPS 5-7 IN REVERSE ORDER TO RETURN VEHICLE TO ORIGINAL STATE

- Check for DTCs.
- Restore customer settings.
- Campaign Complete Return vehicle to original state.

VIII. CHECK INTUITIVE PARKING ASSIST SYSTEM (VEHICLES W/ Backup Camera only)

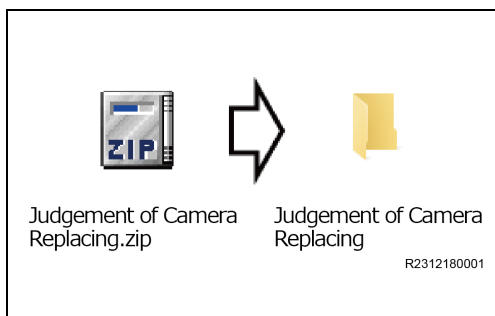

- PREPARATION OF INSPECTION TOOL**
 - Prepare the ADVi or PC.
 - Download the inspection tool from **HERE** and save it on the desktop.
File name: Judgement of Camera Replacing.zip
 - Unzip and extract the downloaded ZIP file and check that each file is created.

NOTICE:
DO NOT delete the files inside the folder.

2. VEHICLE CONNECTION

- Connect the PC to the vehicle through VIM via OBD-II port.
- Turn the IG ON.

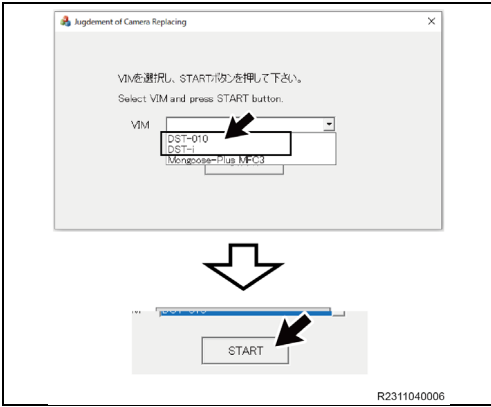

3. SERIAL NUMBER CHECK

- Close any running software such as GTS+.
- Launch “**Judgement of Camera Replacing.exe**”.
- Plug mongoose cable into OBD-II port from PC.
- Select the connected VIM from the pulldown menu of "VIM".
- Click "START" to start the inspection.

HINT:

When the inspection starts, the serial number of the camera is automatically acquired and displayed in the S/N field.

- Check the replacement necessity of the camera from the result displayed in the "Judgment" field, and record it on the check sheet.

	Result	Action
NG	<p>"Need to Replace" is displayed.</p>	<p>Replacement of rear camera is REQUIRED</p> <p style="text-align: center;">↓</p> <p>Replace the rear camera with a new one. Go to IX. STEP 2 - REPLACE TELEVISION CAMERA ASSEMBLY REAR.</p>
OK	<p>"No Need" is displayed</p>	<p>Replacement of cameras is NOT REQUIRED</p> <p style="text-align: center;">↓</p> <p>Restore the vehicle and work is complete. Continue to step 4.</p>



4. CLOSE SOFTWARE

- Click the "X" button to close the application.
- Turn the IG OFF.

5. RETURN VEHICLE TO ORIGINAL STATE

- Check for DTCs.
- Restore customer settings.
- Campaign Complete Return vehicle to original state.

IX. REPLACE TELEVISION CAMERA ASSEMBLY

1. REMOVE TELEVISION CAMERA ASSEMBLY (FRONT)

[PARK ASSIST / MONITORING: TELEVISION CAMERA \(for Front\): REMOVAL; 2023 - 2025 MY Crown \[12/2022 - \]](#)

2. REMOVE TELEVISION CAMERA ASSEMBLY (REAR)

[PARK ASSIST / MONITORING: TELEVISION CAMERA \(for Rear\): REMOVAL; 2023 - 2025 MY Crown \[12/2022 - \]](#)

3. INSTALL TELEVISION CAMERA ASSEMBLY (FRONT)

[PARK ASSIST / MONITORING: TELEVISION CAMERA \(for Front\): INSTALLATION; 2023 - 2025 MY Crown \[12/2022 - \]](#)

4. INSTALL TELEVISION CAMERA ASSEMBLY (REAR)

[PARK ASSIST / MONITORING: TELEVISION CAMERA \(for Rear\): INSTALLATION; 2023 - 2025 MY Crown \[12/2022 - \]](#)

X. CALIBRATE CAMERA SYSTEM

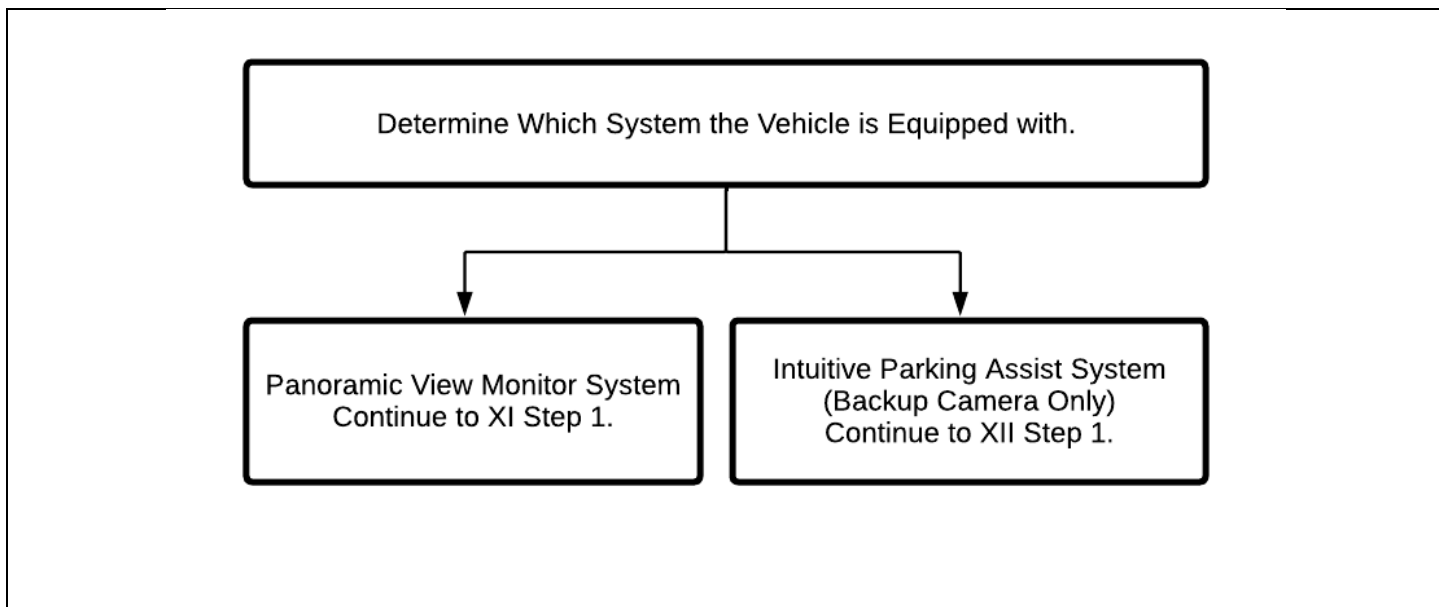

XI. CAMERA ADJUSTMENT PANORAMIC VIEW MONITOR SYSTEM

1. CALIBRATE THE PANORAMIC VIEW MONITOR SYSTEM

[PARK ASSIST / MONITORING: PANORAMIC VIEW MONITOR SYSTEM: CALIBRATION; 2023 - 2025 MY Crown \[12/2022 - \]](#)

XII. CAMERA ADJUSTMENT (VEHICLES W / PARKING ASSIST MONITOR SYSTEM) BACKUP CAMERA ONLY

1. PARKING ASSIST MONITOR SYSTEM INITIALIZATION

[PARK ASSIST / MONITORING: PARKING ASSIST MONITOR SYSTEM: CALIBRATION; 2023 - 2025 MY Crown \[12/2022 - \]](#)

◀ VERIFY REPAIR QUALITY ▶

- Check for DTCs.
- Confirm Camera System is functioning properly.

If you have any questions regarding this update, please contact your regional representative.

XIII. APPENDIX

A. CAMPAIGN DESIGNATION DECODER

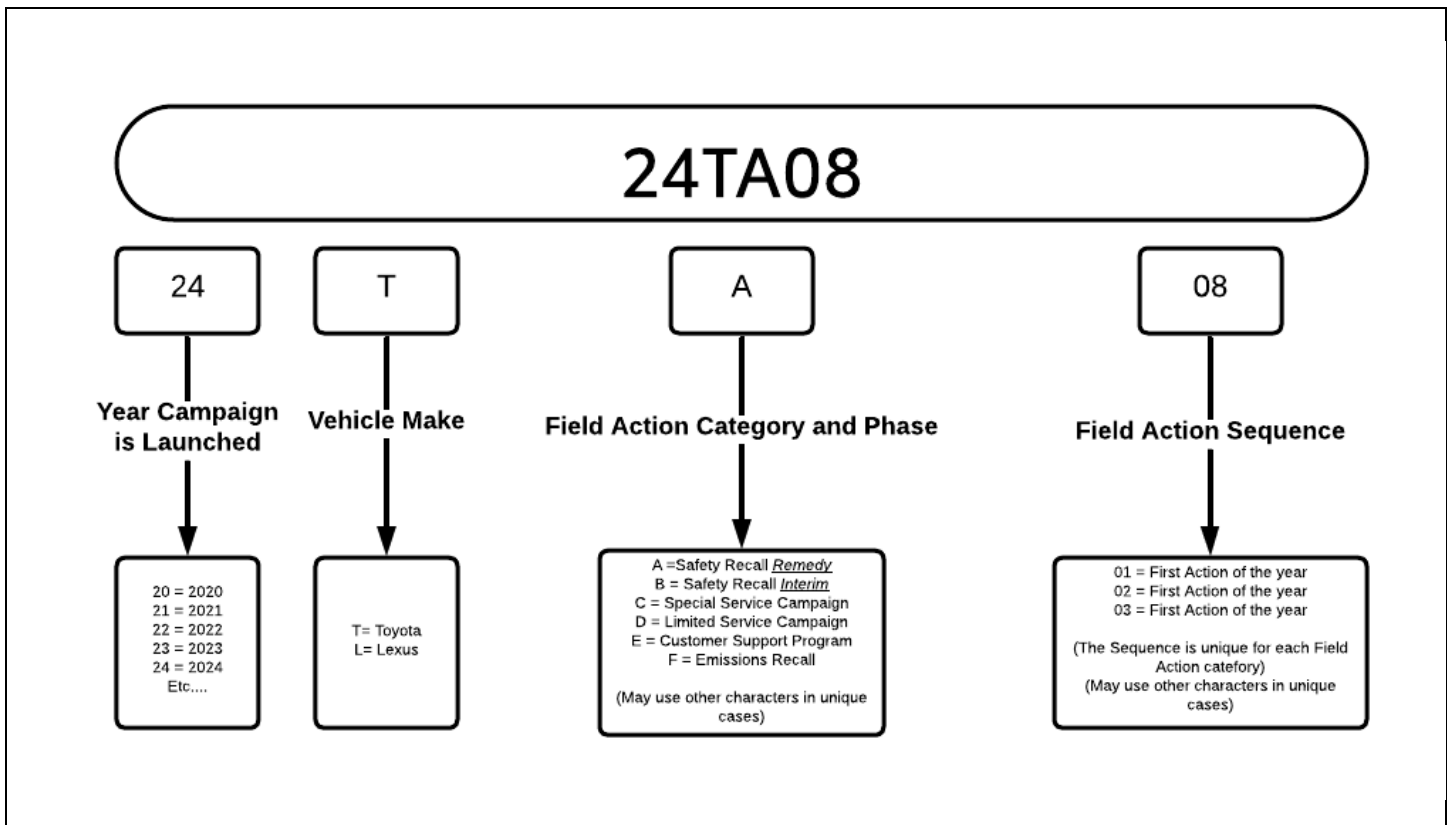

Examples:

19TA01 = Launched in 2019, Toyota, Safety Recall Remedy Phase, 1st Safety Recall Launched in 2019
20TC02 = Launched in 2020, Special Service Campaign, 2nd Special Service Campaign Launched in 2020
21TE05 = Launched in 2021, Customer Support Program, 5th Customer Support Program Launched in 2021

B. CAMPAIGN PARTS DISPOSAL

As required by Federal Regulations, please make sure all campaign parts (original parts) removed from the vehicle are disposed of in a manner in which they will not be reused, ***unless requested for parts recovery return.***