

# SAFETY RECALL

**Mack Trucks Inc.**

Greensboro, NC USA



---

Date	Number	Release	Page
06. 2024	SC0446	01	1 (5)

## **Tie Rod Ball Stud AN, PI**

### **RECALL INFORMATION**

Mack Trucks has determined that certain 2025 AN and PI model vehicles may have been built with Tie Rods containing a ball stud with improper heat treatment. The improper heat treatment of the tie rod ball stud could result in a loss of steering.

Mack Trucks has not received warranty claims, field reports, or service reports because of this issue.

To ensure that these vehicles meet Mack's rigorous quality requirements, follow the instructions outlined below to inspect and/or replace the track rod assembly as necessary.

### **VEHICLES AFFECTED**

Certain Mack North America vehicles manufactured April 29<sup>th</sup>, 2024, through May 29<sup>th</sup>, 2024.

### **VEHICLE QUANTITY**

There are 7 vehicles affected by this recall (All U.S.)

## Parts

Please order parts under VOR. Please use the Part Number Prefix and Program Number below when ordering the part in PARTS LINQ DFS.

Program Number	SMS210417
Part Number Prefix	2719

**NOTE: Perform track rod inspection before ordering parts.**

Part Number	Part description	Quantity
10036700	Track Rod Assembly	1 As Needed

### Inspection Instructions

1. Secure vehicle for service by parking on a flat and level surface.
2. Apply parking brake.
3. Place the transmission in neutral or park.
4. Install the wheel chocks.

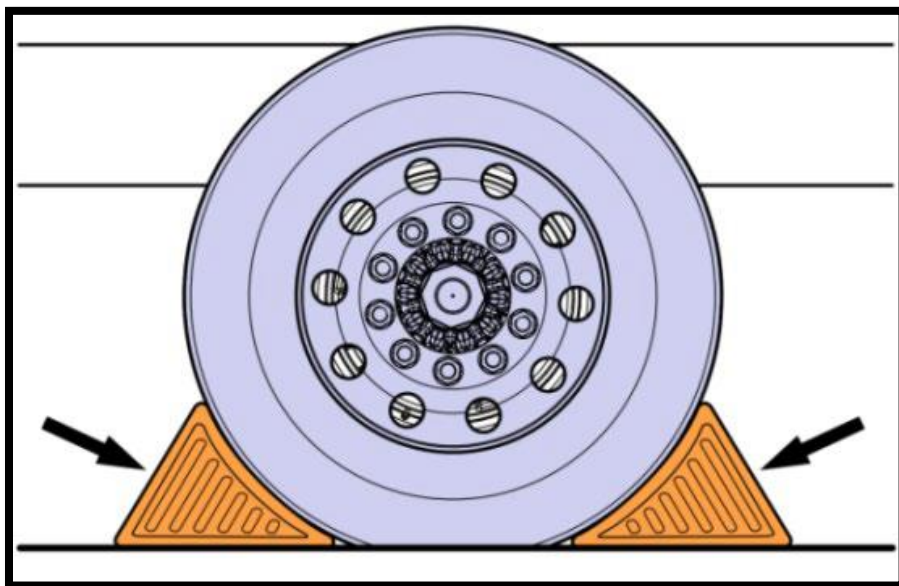

5. Identify the Track Rod assembly.

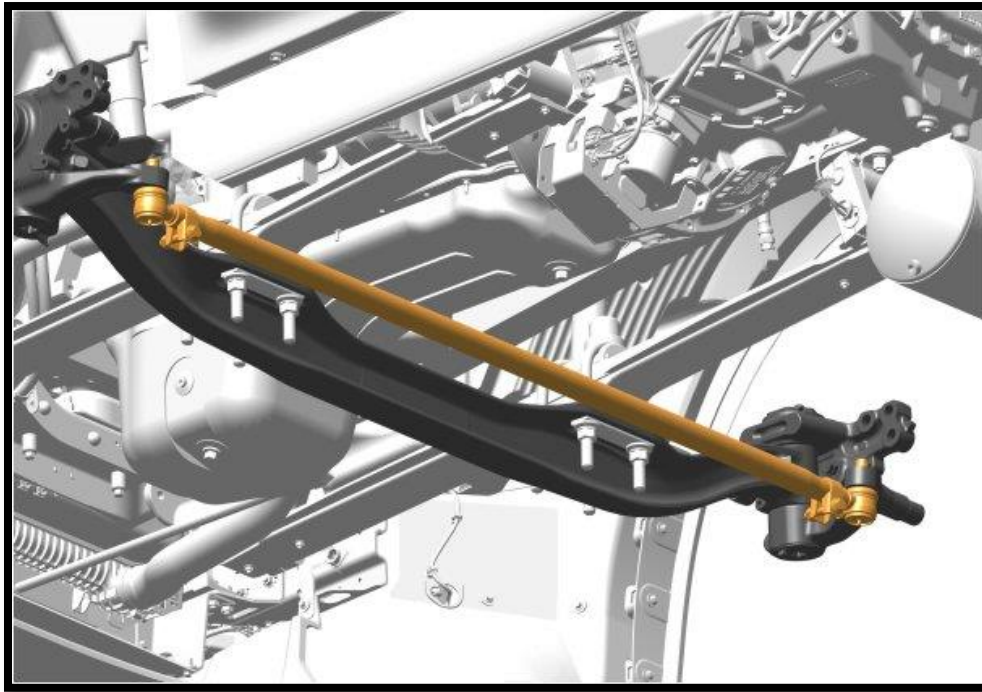

6. Locate the part number stamped or etched on the Track Rod.



7. Verify the part number on the track rod is 10036700.

- a. If the build date matches to the dates on the table, the draglink is NOK and must be replaced with a new one. Proceed to Repair Instructions.
- b. If the build date is not on the table, the draglink is OK, and the truck can be returned to service.

Track Rod Part Number	Suspected Build Date Code			
10036700	100-24	103-24	106-24	107-24

**NOTE: VERIFY PART USING FIRST 5 DIGITS (ex. 100-24). ANY DIGIT AFTER DOES NOT MATTER.** If part number is not on the list or if further assistance is needed locating part number or build date, contact the campaign team at [campaign@volvo.com](mailto:campaign@volvo.com).

### Repair Instructions (Only if Track Rod is Deemed Suspect)

1. Disconnect the cable from the negative terminal.

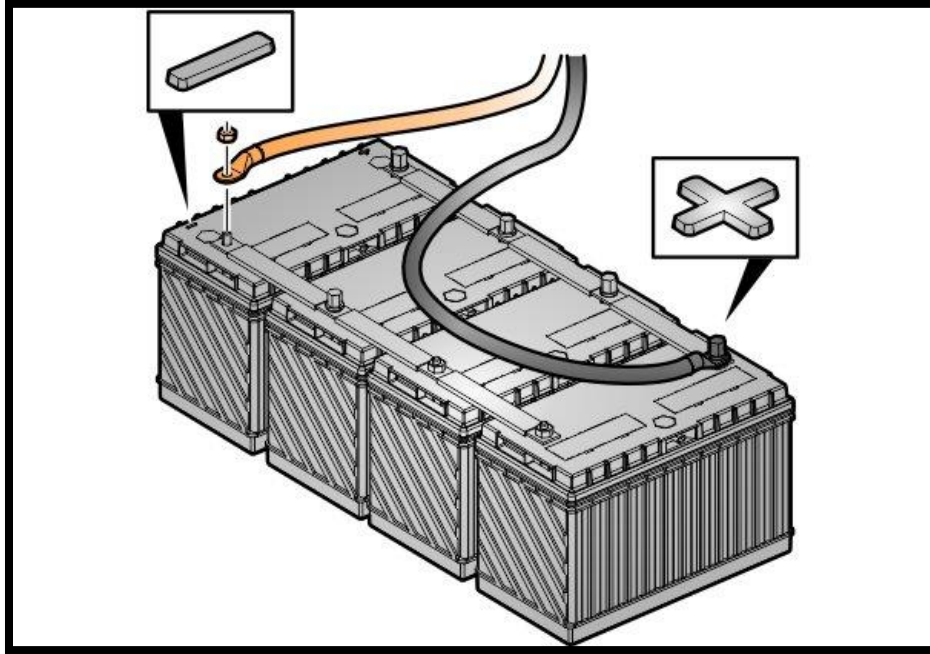

2. Set the wheels straight ahead.

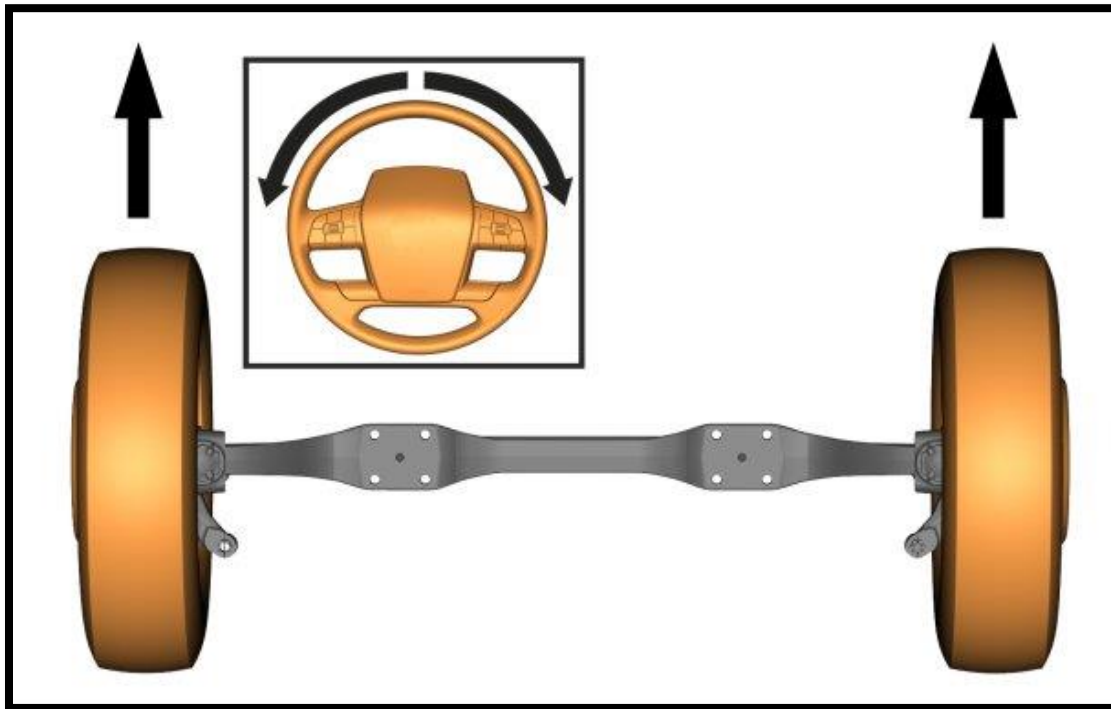

3. Raise the vehicle and place on jack stands.

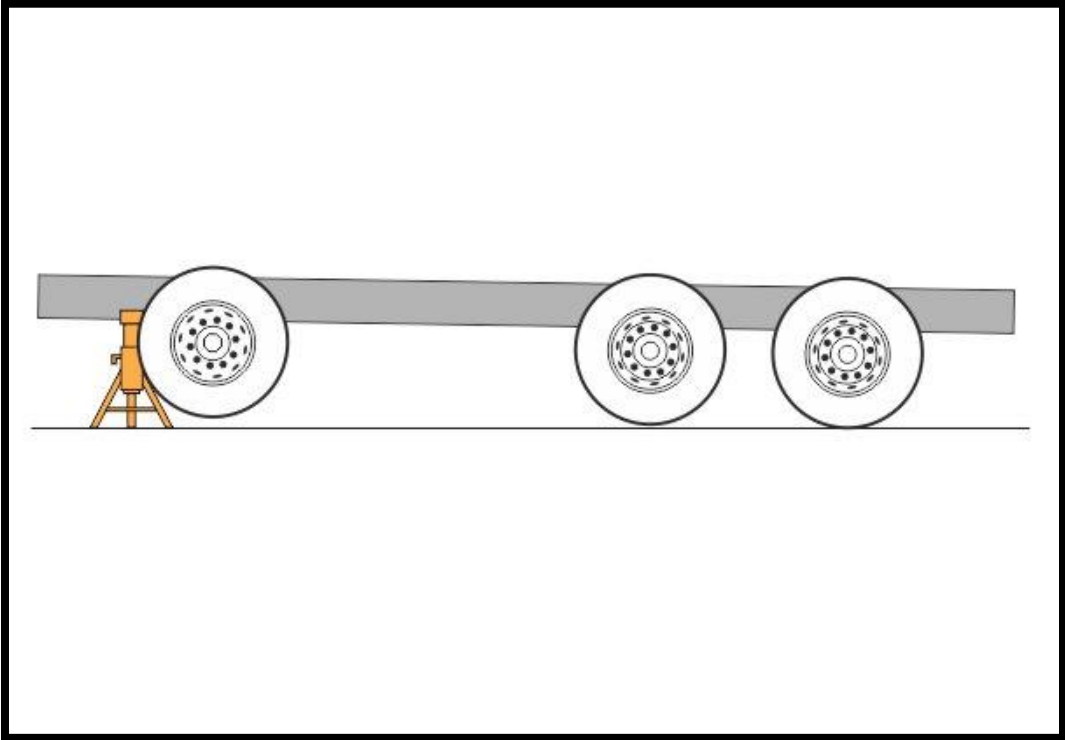

4. Remove both front wheels.

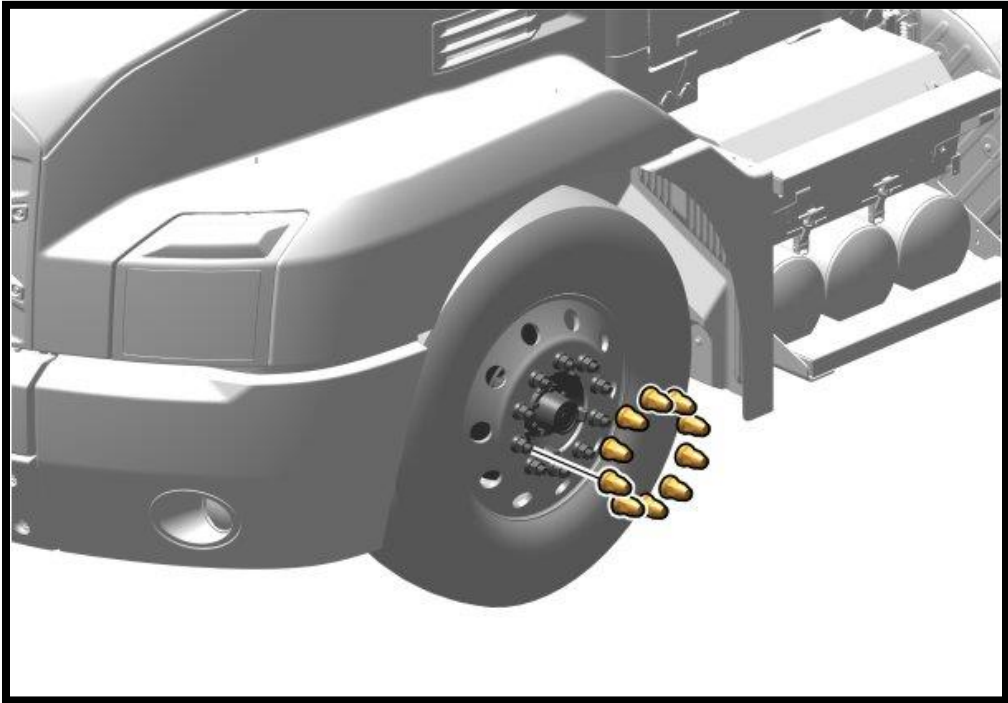

5. Remove the split pin and remove both track rod castle nuts.

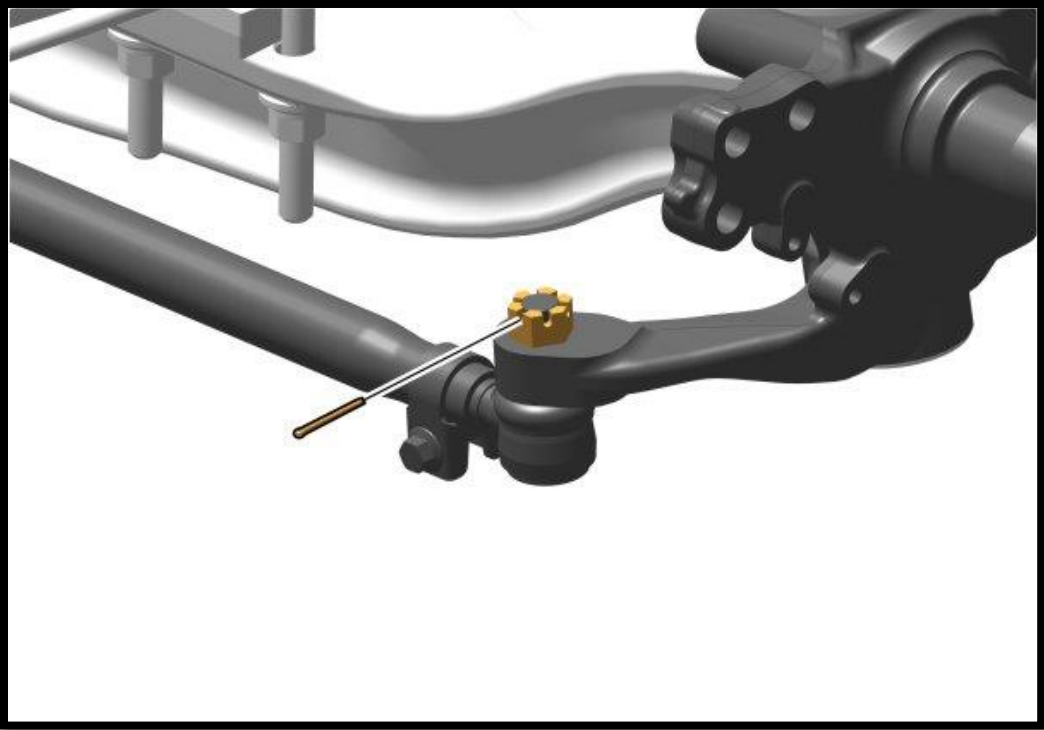

6. Release the ball joint.

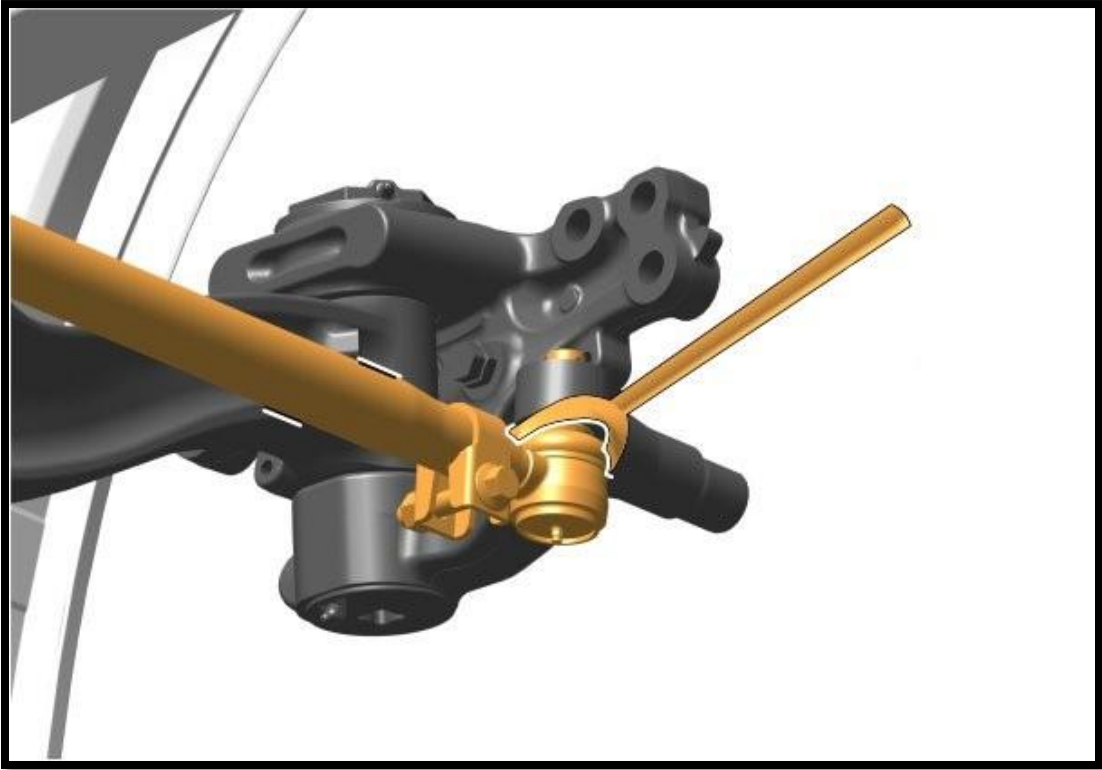

7. Remove the track rod.

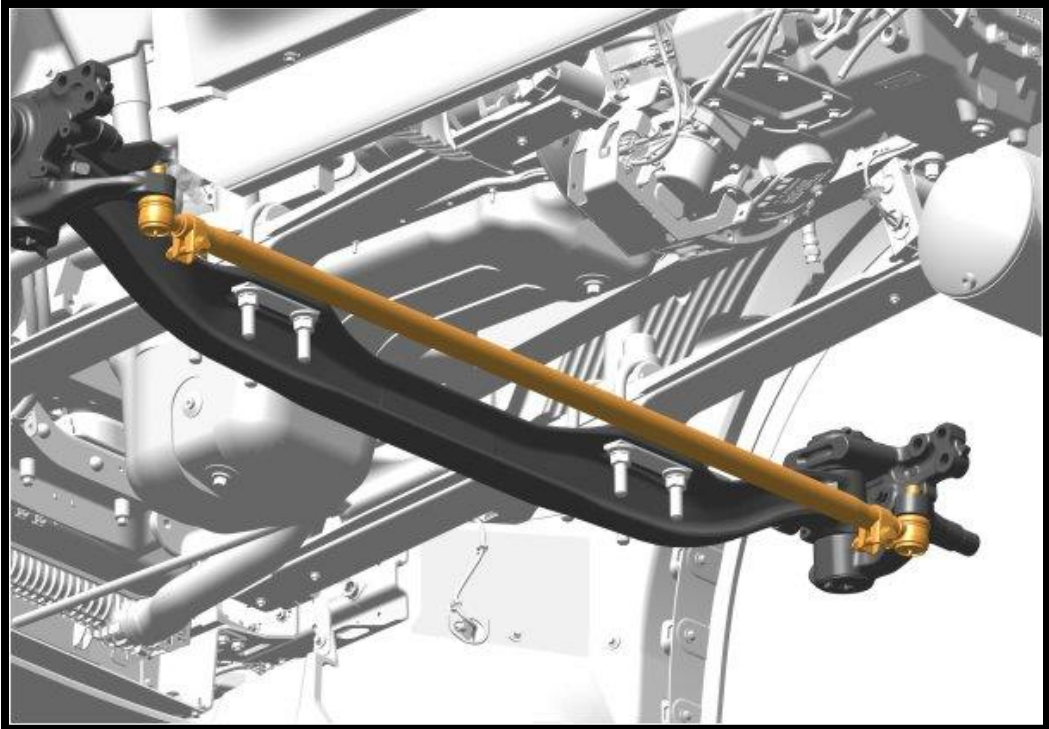

8. Install new track rod.

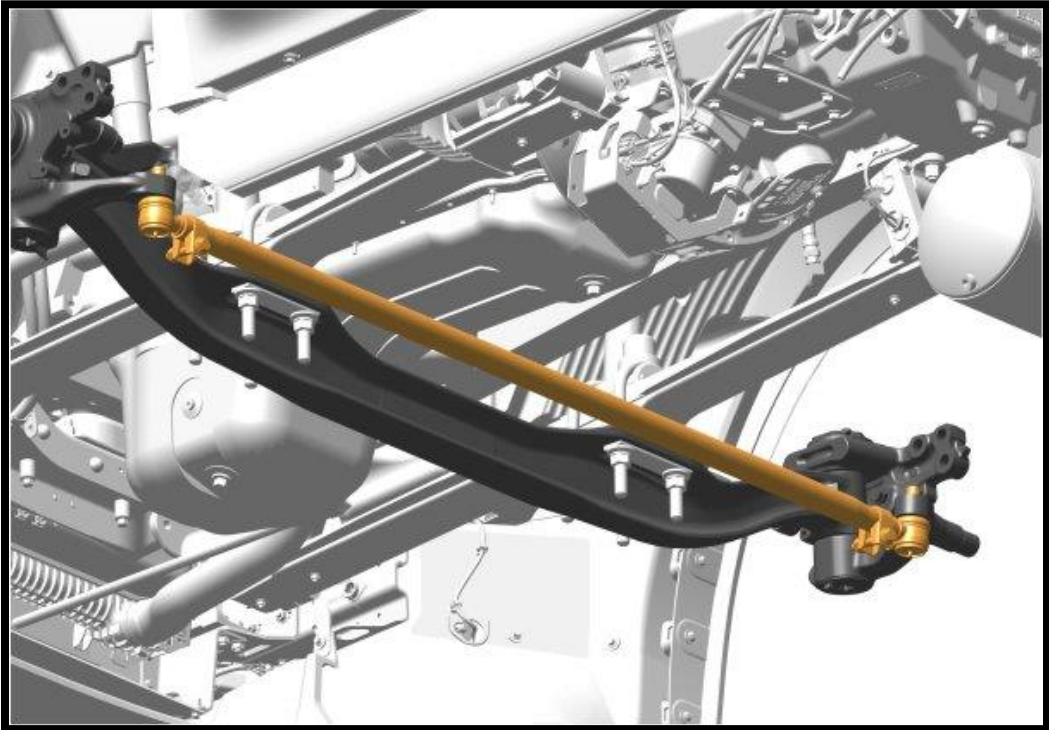

9. Install castle nuts and torque.

Tie rod, nut	163-217 Nm (120-160 lb <sub>f</sub> -ft)
--------------	---

10. Install new spilt pins.

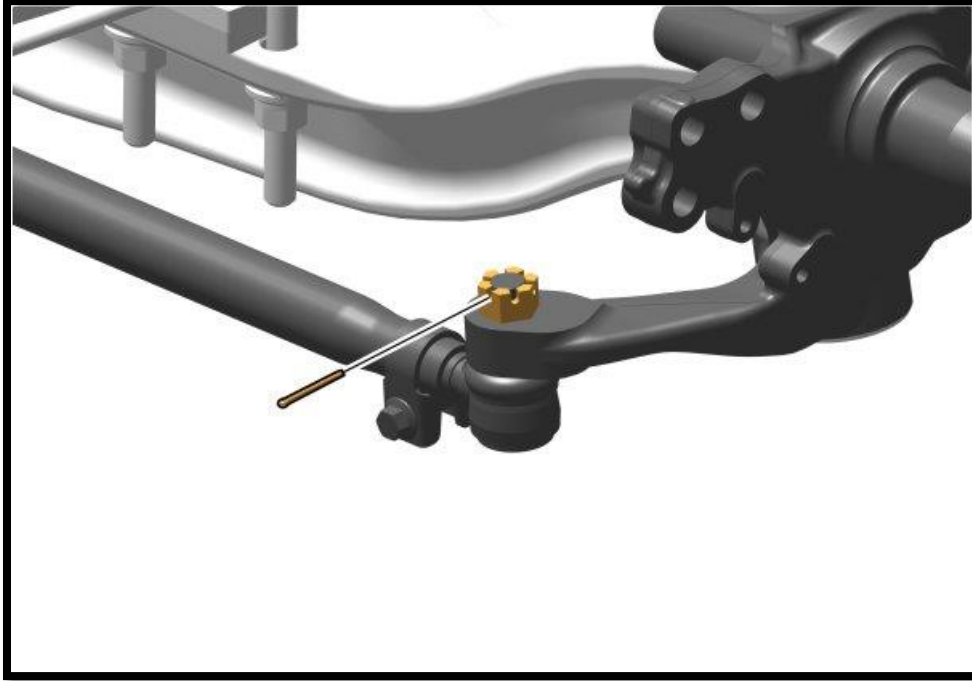

11. Install and torque both front wheels.

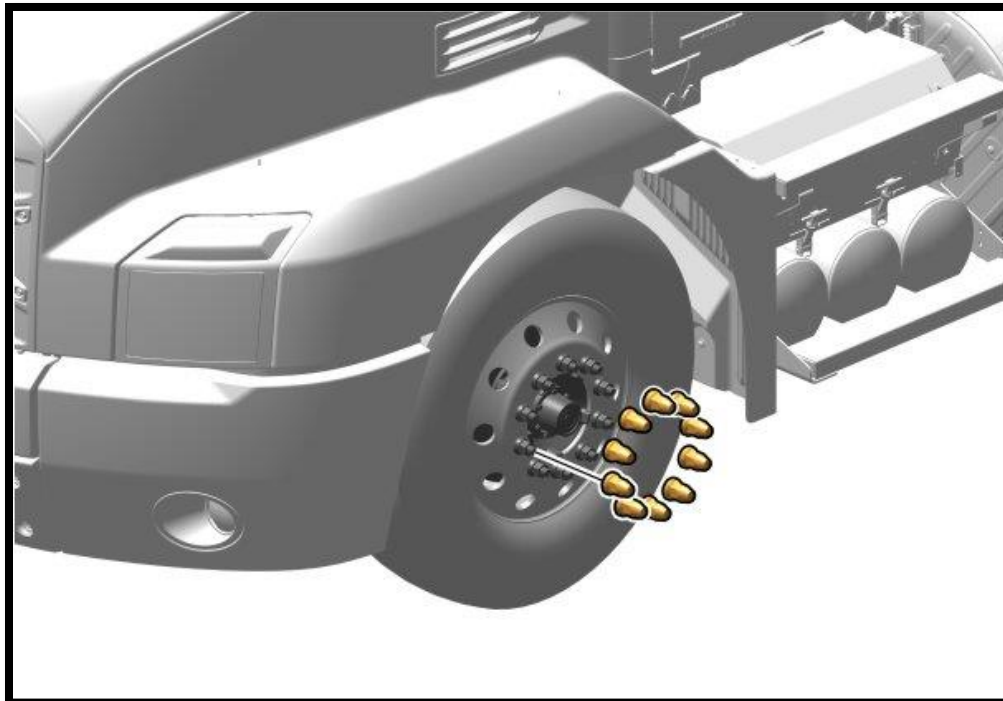



12. Remove jack stands and lower vehicle.

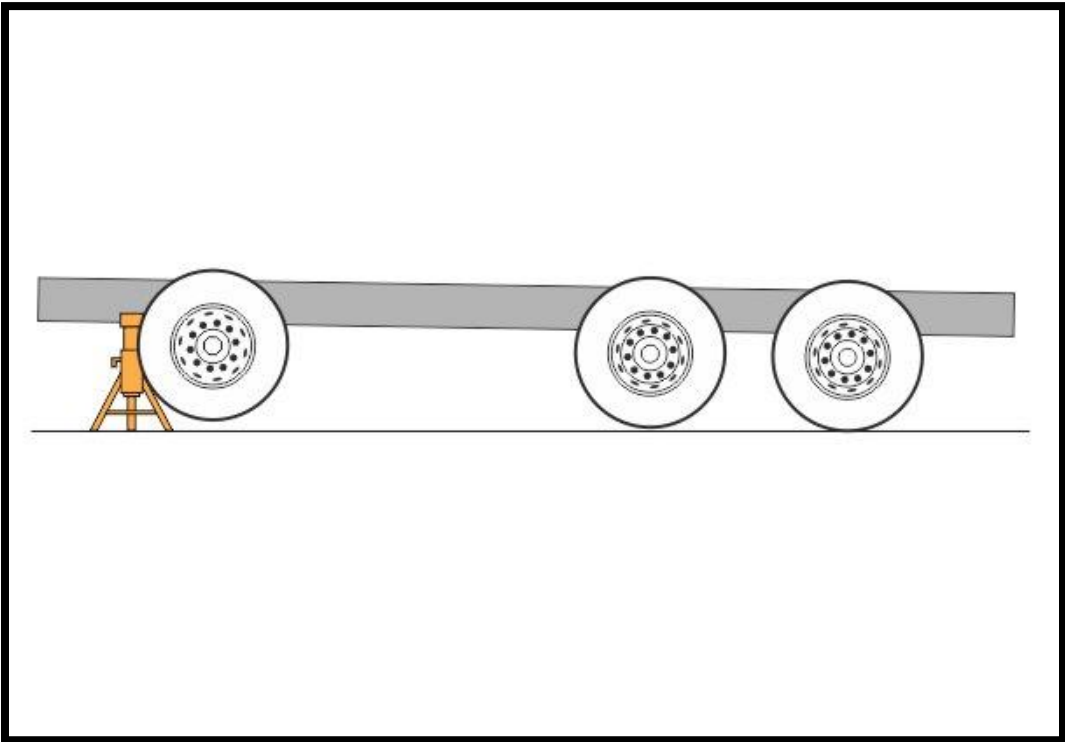

13. Connect the cable to the negative terminal.

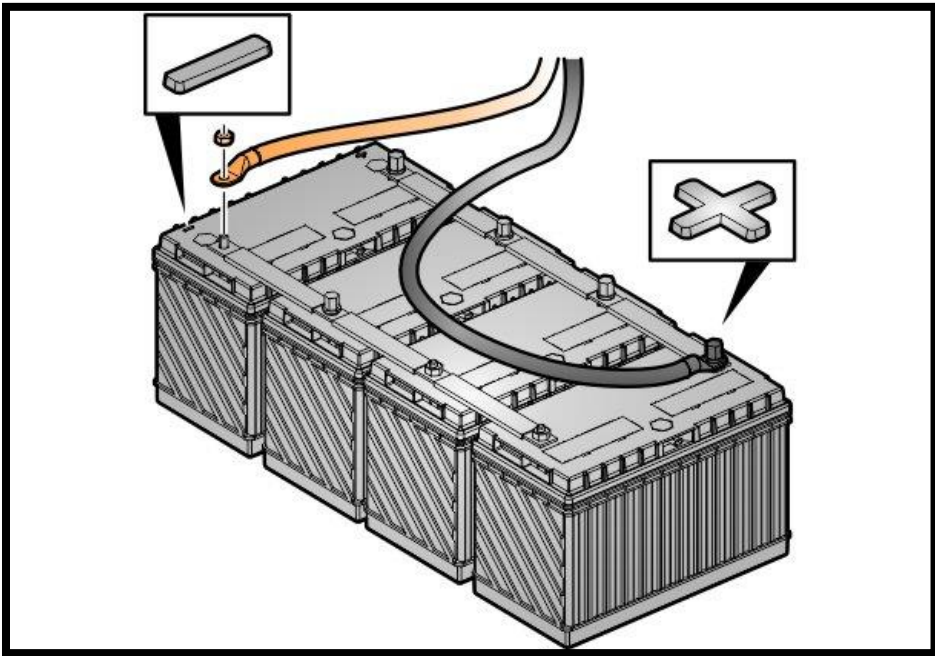

14. Loosen the nuts.

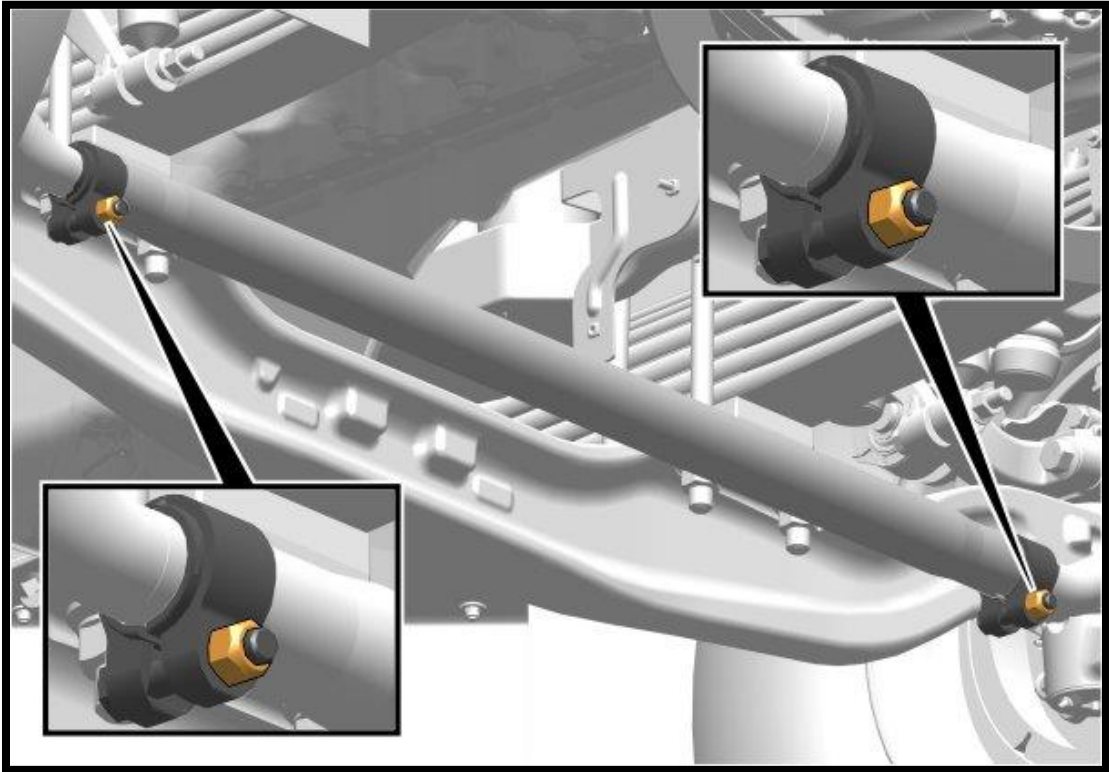

15. Adjust the inner rod to the correct value.

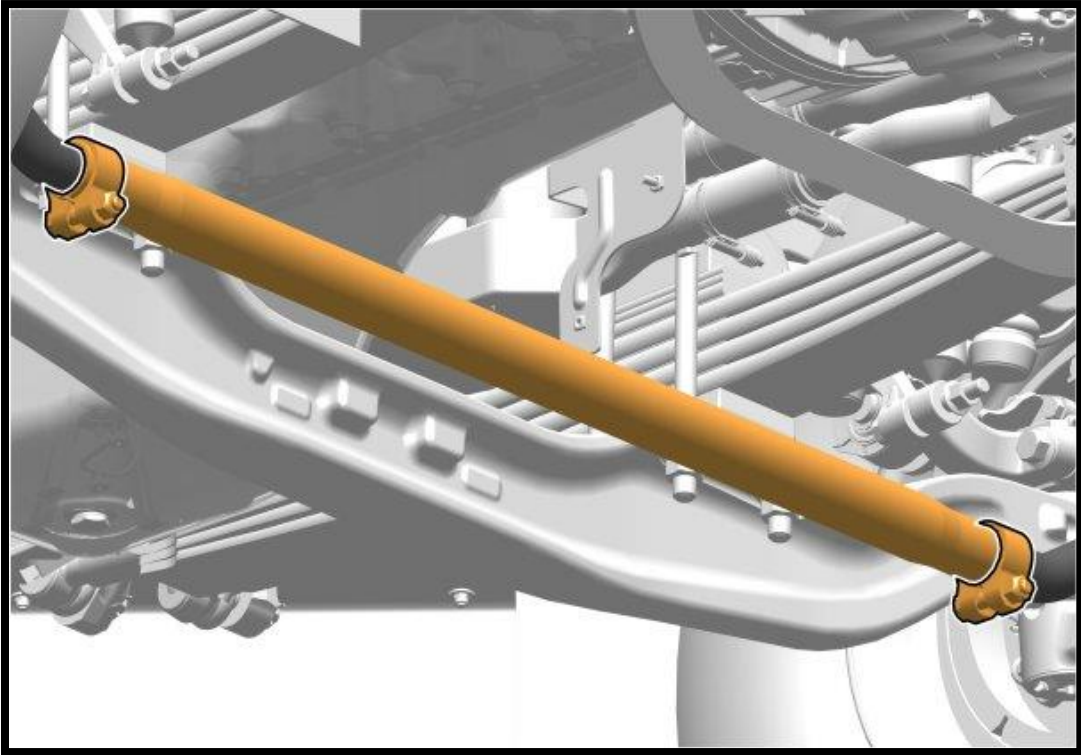

16. Torque tighten the nuts.

Tie rod, clamp, nut

61-81 Nm  
(45-60 lb<sub>r</sub>·ft)

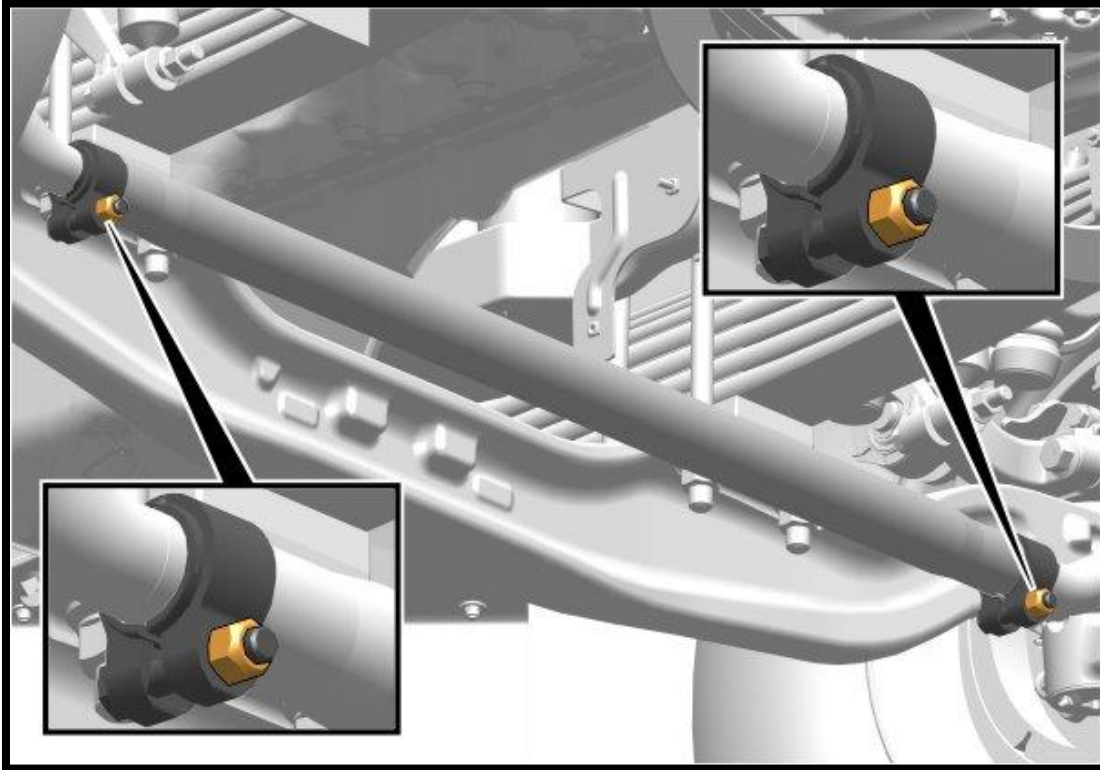

17. Remove wheel chocks.

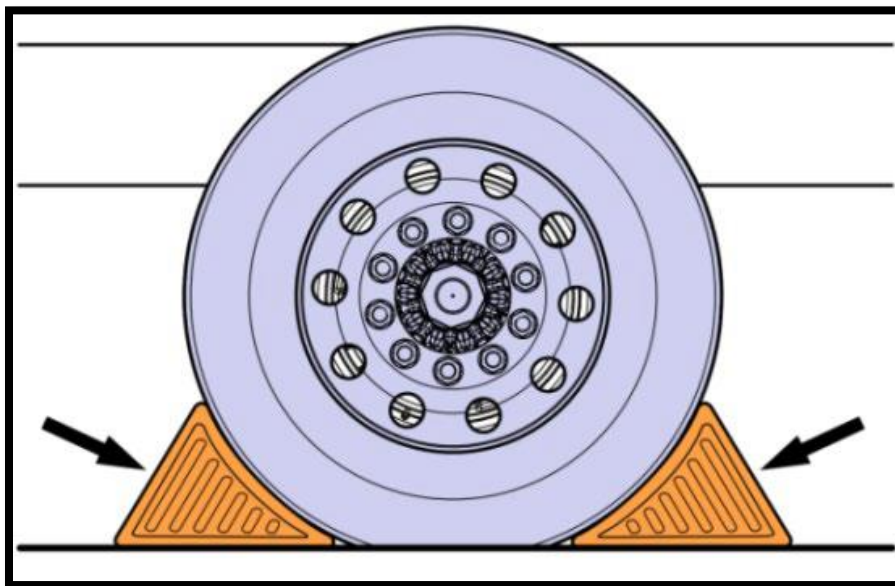

18. Return the truck to service.

## REIMBURSEMENT

### IMPORTANT NOTE:

Due to the nature of the Do Not Drive Recall, towing or technician travel may be considered on a case-by-case basis.

This repair is covered by an authorized Safety Recall. Reimbursement is obtained through the normal claim handling process.	
	<b>UCHP Reimbursement</b>
<b>Claim Type</b> (used only when uploading from the Dealer Business System)	40
<b>Recall Status</b>	
Vehicle repaired per instructions	1-Modified per instructions
<b>Primary Labor Code</b>	
1720-16-09-01 Campaign, General X 3	SRT (0.1 x 3) .3 hrs.
<b>If Tie Rod End Replacement Is Needed</b>	
6431-01-01-01 Track Rod removal x1	0.6
6430-02-01-01 Track Rod Installation (Include Toe adjustment) x1	0.8
<b>Causal Part</b>	23057988
<b>Authorization Number</b>	C0385

**Note:** Dealers or the designated representatives are to perform Safety Recall on all subject vehicles at no charge to the vehicle owner regardless of mileage, age of vehicle or ownership (original purchaser or subsequent purchasers). Whenever vehicles that are subject to a Safety Recall are brought to your dealership for service, it is strongly recommended that every effort be made to perform the recall correction before the vehicle is released to the owner.