

PartNo	Alt PartNo	DRG. NO.	REV.	DESCRIPTION
24 V-403		24 V-403		

1. LOCATE THE NUTS AND BOLTS SHOWN IN DETAIL "A"
2. REMOVE NUTS AND BOLTS AND REPLACE WITH NEW HARDWARE ENSURING THE BOLT GOES THROUGH THE ENTIRE NUT. A MINIMUM OF 2 THREADS SHOULD STICK OUT BEYOND THE NUT.
3. TORQUE TO 8 FTLB DRY.
4. DISCARD OLD HARDWARE.
5. PARTS INCLUDED: 4X BOLTS 03213114, 4X NUTS 03261805

**\*\* DO NOT RE-USE LOCK NUTS \*\***

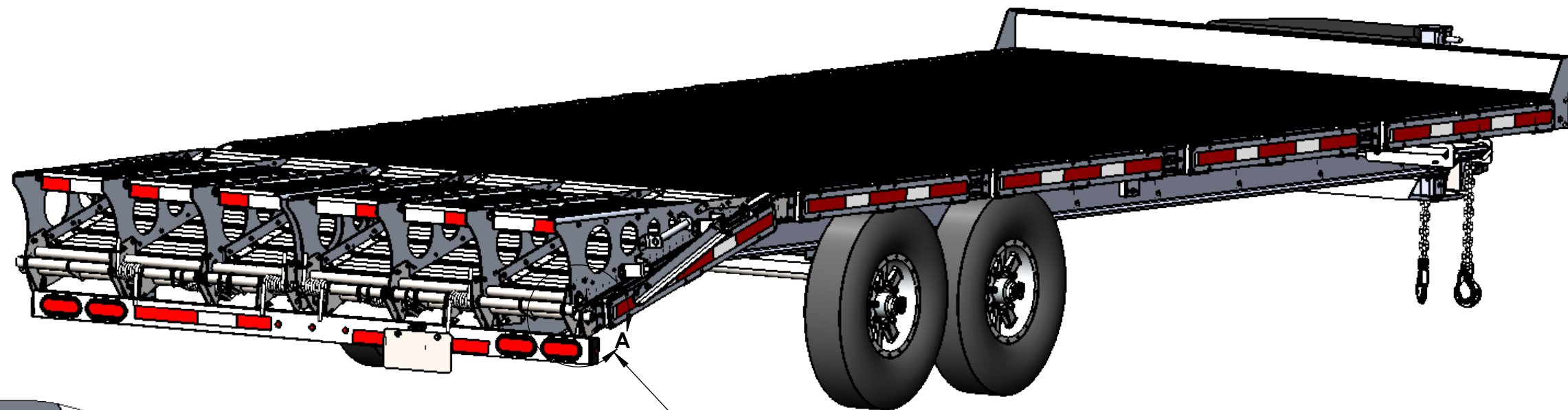

DETAIL "A"

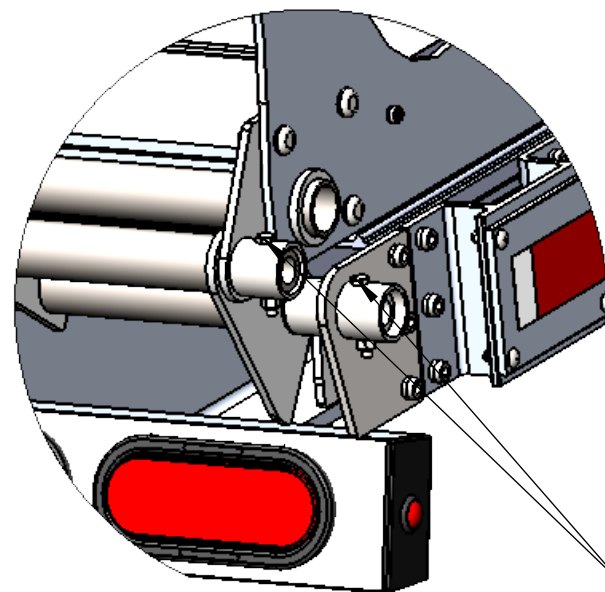

DETAIL A  
SCALE 1 : 5

**REPLACE NUT AND BOLT  
2X EACH SIDE OF RAMP**

REV	DESCRIPTION	DATE	BY
<small>This drawing is the property of TIMPTE, INC. and is loaned with the following conditions:            1. It shall not be used in any way deleterious to the interests of TIMPTE, INC.            2. Neither this drawing nor any of the information contained herein shall be used for the making of drawings, prints or for any other purpose, including without limitation, the making or manufacturing of any thing, apparatus, or part, except upon the prior written consent of TIMPTE, INC.            3. Upon request this drawing and all copies thereof shall be returned to TIMPTE, INC.            4. The information contained in this drawing is confidential and shall not be conveyed to any other person, party, or entity outside of the organization or entity.            5. The acceptance of this drawing is an acceptance of the foregoing terms and conditions and an admission that TIMPTE, INC. is the exclusive owner in and to the drawing and information and shall constitute a binding contract.</small>			
<b>DIMENSIONS IN INCHES UNLESS OTHERWISE NOTED</b>		<b>TOLERANCES—EXCEPT AS SPECIFIED</b> ANGLE: +/- 2°      DECIMALS: FRACTIONS:      .X +/- .1 HOLE LOC. +/- 1/32"      .XX +/- .03 OTHER      +/- 1/16"      .XXX +/- .002	
DATE DRWN:	06/03/2024	<b>TIMPTE</b> ®	
DATE REL:	06/03/2024	TITLE: 14K DECK OVER RECALL	
APP BY:			
SCALE:	VARIES		
DRWN BY:	KRC	DRAWING NO.:	24 V-403