

SAFETY RECALL

Mack Trucks Inc.
Greensboro, NC USA



Date	Number	Release	Page
06.2024	SC0465	02	1(5)

Steering Draglink AN, GR, TE

REVISION 2: Additional population added, updated part numbers with affected build dates. Previously inspected trucks before this revision will be added to C0384 Steering Draglink Additional Inspection. Contact campaign@volvo.com if support is needed.

RECALL INFORMATION

(June 2024)

Mack Trucks has determined that certain model year 2025 AN, GR, and TE may have been built with draglinks containing a ball stud with improper heat treatment. This could result in loss of steering.

Mack Trucks has not received warranty claims, field reports, or service reports because of this issue.

To ensure that these vehicles meet Mack's rigorous quality requirements, follow the instructions outlined below to inspect and/or repair the draglink as necessary.

VEHICLES AFFECTED

Certain Mack vehicles manufactured between April 10th, 2024, and May 24th, 2024.

VEHICLE QUANTITY

There are 1080 vehicles affected by this recall. (860 U.S., 147 CAN., 73 export)

Parts

Parts

Order parts through normal process as needed.

NOTE: Draglink part number DID NOT change. If draglink replacement is required, replace with same part number as what was removed.

IMPORTANT NOTE:		
<p>Verify build date of replacement draglink before installing. If replacement draglink is suspect, DO NOT INSTALL. Only replace with draglink build date not on suspect list. Please reference Parts Recall Bulletin</p>		

Part Number	Part description	Quantity
VIN per Impact	Drag Link	As Needed

Repair Instructions

1. Secure vehicle for service by parking on a flat and level surface.
2. Apply parking brake.
3. Place the transmission in neutral or park.
4. Install the wheel chocks.

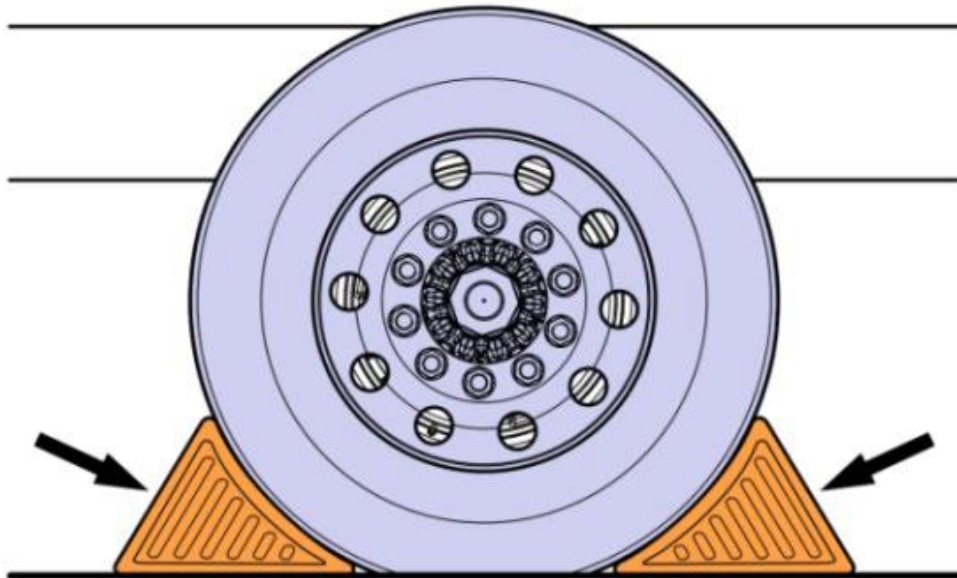

5. Identify the draglink assembly connecting the steering lever and the pitman arm.

NOTE: Some trucks may have dual draglinks depending on configuration.

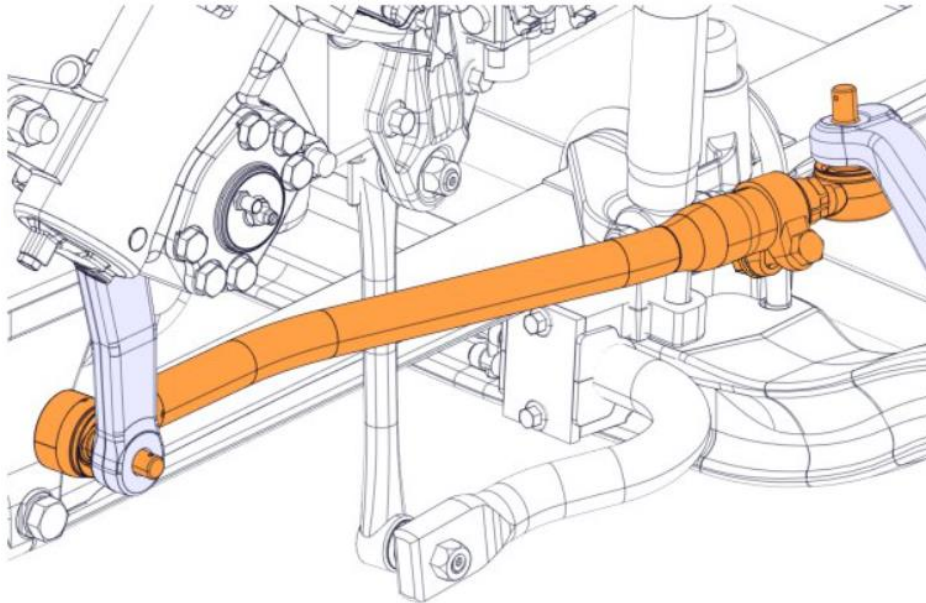

6. Locate the part number stamped or etched on the draglink.

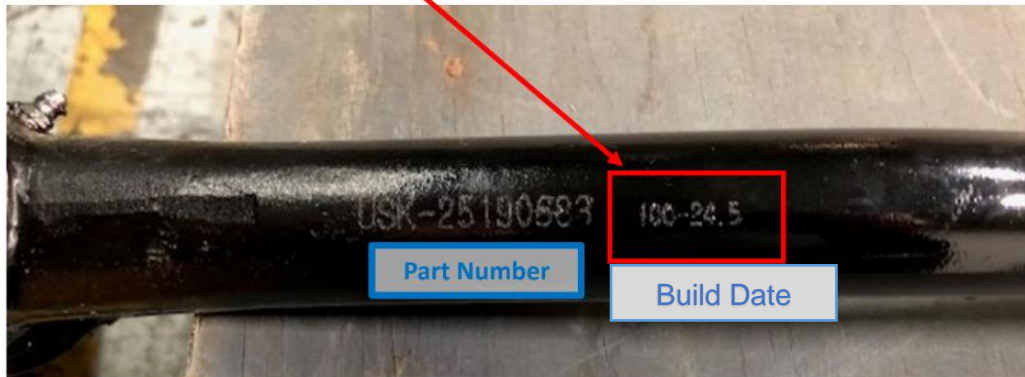

7. Verify the part number on the draglink to the reference part number in the table below. Confirm whether the part number and build date match or not.
 - a. If the build date matches to the dates on the table, the draglink is NOK and must be replaced with a new one. Proceed to step 8.
 - b. If the build date is not on the table, the draglink is OK and the truck can be returned to service.

IMPORTANT NOTE:

Please inspect the draglink for the following part numbers and their respective build dates. IF the date matches one from the list below, the draglink **MUST** be replaced. IF the date does not match, the truck is considered OK and can return to service.

NOTE: VERIFY PART USING FIRST 5 DIGITS (ex. 100-24). ANY DIGIT AFTER DOES NOT MATTER. If part number is not on the list or if further assistance is needed locating part number or build date, contact the campaign team at campaign@volvo.com

Part Number	NOK Suspect Build Date
85128559	100-24
	101-24
	104-24
	106-24
	107-24
	108-24
	116-24
	117-24
	120-24
	121-24
20966804	124-24
	100-24
	110-24
	114-24
	117-24
25190682	122-24
	125-24
	127-24
	101-24
25190863	102-24
	117-24
	118-24
21129355	100-24
	111-24
	116-24
22834992	102-24
	109-24
	113-24
22595406	103-24
	110-24
23032385	102-24
	114-24
23032389	101-24
	114-24
23626616	100-24
	106-24
	108-24
	114-24
23685511	117-24
	103-24
	106-24
24540119	106-24
20966803	106-24
22607488	109-24
22660547	110-24

8. If draglink needs to be replaced, follow **Impact Procedure 6438-03-02-01 Link Rod, Replacement.**

REIMBURSEMENT

IMPORTANT NOTE:

Due to the nature of the Do Not Drive Recall, towing or technician travel may be considered on a case-by-case basis.

<p>This repair is covered by an authorized Safety Recall. Reimbursement is obtained through the normal claim handling process.</p>	
	UHP Reimbursement
<p>Claim Type (used only when uploading from the Dealer Business System)</p>	40
<p>Recall Status</p>	
<p>Vehicle repaired per instructions</p>	1-Modified per instructions
<p>Primary Labor Code</p>	
<p>Primary Labor Code: 1720-16-09-01 Campaign, General X 3</p>	<p>SRT (0.1 x 3) .3 hrs.</p>
<p>If needed:</p>	
<p>6438-03-02-01 Link Rod, Replacement X 1</p>	<p>Will vary by VIN</p>
<p>Causal Part</p>	23685511
<p>Authorization Number</p>	C0382

Note: Dealers or the designated representatives are to perform Safety Recall on all subject vehicles at no charge to the vehicle owner regardless of mileage, age of vehicle or ownership (original purchaser or subsequent purchasers). Whenever vehicles that are subject to a Safety Recall are brought to your dealership for service, it is strongly recommended that every effort be made to perform the recall correction before the vehicle is released to the owner.