

SAFETY RECALL

Volvo Trucks North America

Greensboro, NC USA

VOLVO

Date	Number	Release	Page
06. 2024	RVXX2402	01	1 (5)

Steering Draglink VN, VNE, VHD

RECALL INFORMATION

(June 2024)

Volvo Trucks has determined that certain model year 2025 VHD, VN, and VNE model vehicles may have been built with draglinks containing a ball stud with improper heat treatment. This could result in loss of steering.

Volvo Trucks has not received warranty claims, field reports, or service reports because of this issue.

To ensure that these vehicles meet Volvo's rigorous quality requirements, follow the instructions outlined below to inspect and/or replace the draglink as necessary.

VEHICLES AFFECTED

Certain Volvo North America vehicles manufactured between April 10th, 2024, and May 24th, 2024.

VEHICLE QUANTITY

There are 594 vehicles affected by this recall (488 U.S., 106 Canada)

Parts

Order parts through normal process as needed.

NOTE: Draglink part number DID NOT change. If draglink replacement is required, replace with same part number as what was removed.

IMPORTANT NOTE:

Verify build date of replacement draglink before installing. If replacement draglink is suspect, DO NOT INSTALL. Only replace with draglink build date not on suspect list. Please reference Parts Recall Bulletin: PSM24-V-NA-44 Safety Recall RVXX2402

Part Number	Part description	Quantity
85128559	Drag Link	As Needed
22595406	Drag Link	As Needed
23032385	Drag Link	As Needed
23032389	Drag Link	As Needed
23626616	Drag Link	As Needed
24540119	Drag Link	As Needed
22607488	Drag Link	As Needed
20966804	Drag Link	As Needed
25190682	Drag Link	As Needed
25190683	Drag Link	As Needed
21129355	Drag Link	As Needed
22834992	Drag Link	As Needed

Repair Instructions

1. Secure vehicle for service by parking on a flat and level surface.
2. Apply parking brake.
3. Place the transmission in neutral or park.
4. Install the wheel chocks.

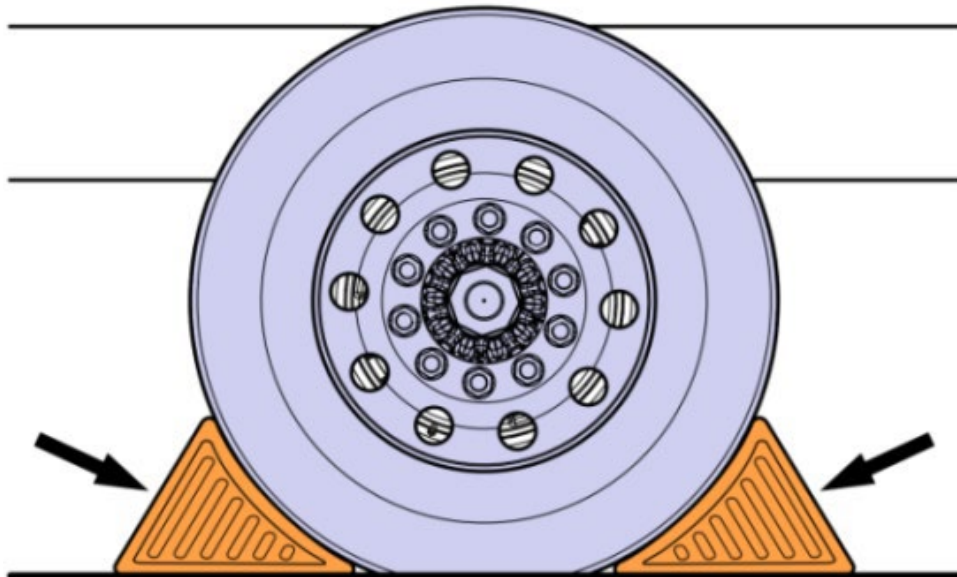

5. Identify the draglink assembly connecting the steering lever and the pitman arm.

NOTE: Some trucks may have dual draglinks depending on configuration.

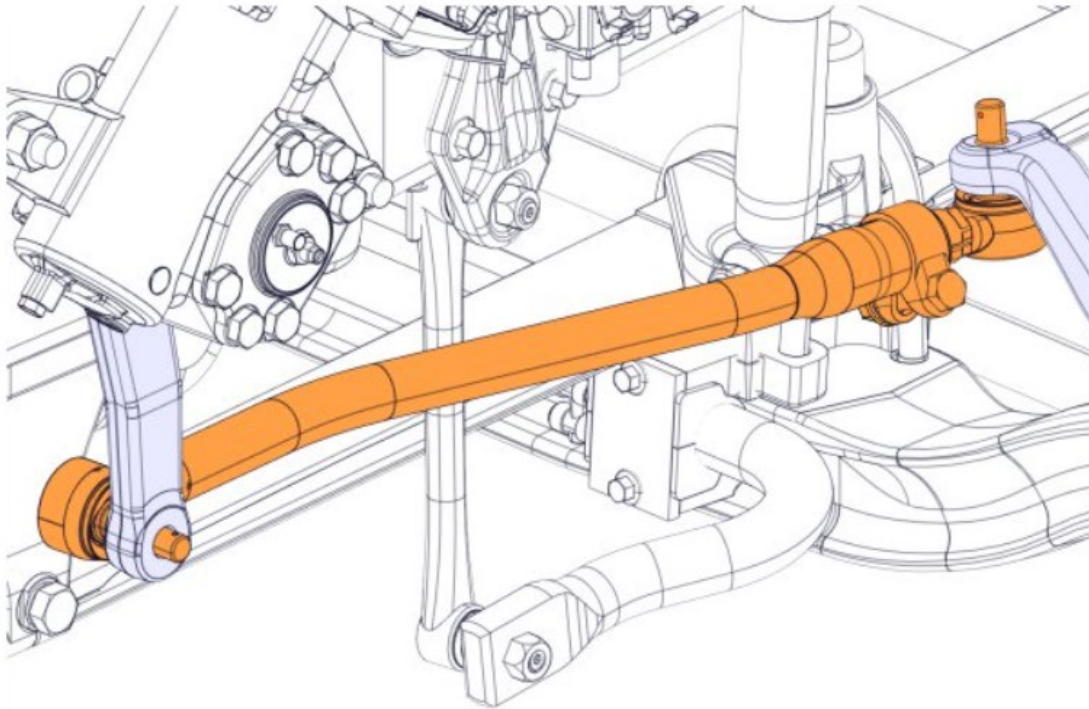

6. Locate the part number stamped or etched on the draglink.



7. Verify the part number on the draglink to the reference part number in the table below. Confirm whether the part number and build date match or not.
 - a. If the build date matches to the dates on the table, the draglink is NOK and must be replaced with a new one. Proceed to step 8.
 - b. If the build date is not on the table, the draglink is OK and the truck can be returned to service.

IMPORTANT NOTE:

Please inspect the draglink for the following part numbers and their respective build dates. IF the date matches one from the list below, the draglink **MUST** be replaced. IF the date does not match, the truck is considered OK and can return to service.

NOTE: If further assistance is needed locating part number or build date, contact the campaign team at campaign@volvo.com.

Part Number	NOK Suspect build Date
85128559	100-24 101-24 104-24 106-24 107-24 108-24 116-24 117-24 120-24 121-24 124-24
22595406	102-24
23032385	101-24 114-24
23032389	100-24
23626616	106-24 108-24 114-24 117-24
24540119	106-24
22607488	109-24
20966804	114-24 117-24 122-24 125-24 127-24
25190682	117-24 118-24
25190683	100-24 116-24
21129355	109-24 113-24
22834992	110-24

8. If draglink needs to be replaced, follow **Impact Procedure 6438-03-02-01 Link Rod, Replacement.**

REIMBURSEMENT

IMPORTANT NOTE:
Due to the nature of the Do Not Drive Recall, towing or technician travel may be considered on a case-by-case basis.

This repair is covered by an authorized Safety Recall. Reimbursement is obtained through the normal claim handling process.	
	UCHP Reimbursement
Claim Type (used only when uploading from the Dealer Business System)	40
Recall Status	
Vehicle repaired per instructions	1-Modified per instructions
Primary Labor Code	
Primary Labor Code: 1720-16-09-01 Campaign, General X 3	SRT (0.1 x 3) .3 hrs.
If needed:	
6438-03-02-01 Link Rod, Replacement X 1	Will vary by VIN
Causal Part	23685511
Authorization Number	C0376

Note: Dealers or the designated representatives are to perform Safety Recall on all subject vehicles at no charge to the vehicle owner regardless of mileage, age of vehicle or ownership (original purchaser or subsequent purchasers). Whenever vehicles that are subject to a Safety Recall are brought to your dealership for service, it is strongly recommended that every effort be made to perform the recall correction before the vehicle is released to the owner.