



# VOLUNTARY RECALL CAMPAIGN

Classification: EL24-007	Reference: NTB24-027	Date: June 20, 2024
-----------------------------	-------------------------	------------------------

## VOLUNTARY SAFETY RECALL CAMPAIGN 2023 ARIYA; TRACTION MOTOR

**CAMPAIGN ID #:** R24A3  
**APPLIED VEHICLES:** 2023 ARIYA (FE0)

**Check Service COMM or Dealer Business Systems (DBS)  
National Service History to confirm campaign eligibility.**

### INTRODUCTION

Nissan is conducting this voluntary safety recall campaign on certain specific model year 2023 ARIYA vehicles to replace the Traction Motor. This service will be performed at no charge to the customer for parts or labor.

### IDENTIFICATION NUMBER

Nissan has assigned identification number R24A3 to this campaign. This number must appear on all communication and documentation of any nature dealing with this campaign.

### DEALER RESPONSIBILITY

It is the dealer's responsibility to check Service COMM or Dealer Business Systems (DBS) National Service History for the campaign status on each vehicle falling within the range of this voluntary safety recall which for any reason enters the service department. This includes vehicles purchased from private parties or presented by transient (tourist) owners and vehicles in a dealer's inventory. **Federal law requires that new vehicles in dealer inventory which are the subject of a safety recall must be corrected prior to sale. Failure to do so can result in civil penalties by the National Highway Traffic Safety Administration.** While federal law applies only to new vehicles, Nissan strongly encourages dealers to correct any used vehicles in their inventory before they are retailed.

Bulletins are intended for use by qualified technicians, not 'do-it-yourselfers'. Qualified technicians are properly trained individuals who have the equipment, tools, safety instruction, and know-how to do a job properly and safely. **NOTE:** If you believe that a described condition may apply to a particular vehicle, DO NOT assume that it does. See your Nissan dealer to determine if this applies to your vehicle.

## REQUIRED SPECIAL TOOLS

New or replacement Essential Tools are available from Tech•Mate online: [www.techmatetools.com](http://www.techmatetools.com), or by phone: 1-833-397-3493.

When ordering, keep in mind that the tool part number prefix has changed from “J” to “NI”. For example, **J**-53355 is now **NI**-53355.

- Slinger Set – NI-53355
- Each EV dealer has been previously shipped one Slinger set (NI-53355).



Figure 1

- Lock Nut Cape Chisel (NI-52982)
- Each dealer has been previously shipped one Lock Nut Cape Chisel (NI-52982).



Figure 2

- Sling Belt (NI-50309)
- Each EV dealer has been previously shipped one Sling Belt (NI-50309).



Figure 3

## SERVICE PROCEDURE

### **⚠ DANGER**

Since hybrid vehicles and electric vehicles contain a high voltage battery, there is the risk of electric shock, electric leakage, or similar accidents if the high voltage component and vehicle are handled incorrectly. To avoid death be sure to follow the correct work procedures when performing inspection and maintenance.

### **⚠ WARNING**

- Be sure to remove the Service Plug in order to disconnect the high voltage circuits before performing inspection or maintenance of high voltage system harnesses and parts.
- The removed Service Plug must always be carried in a pocket of the responsible worker or placed in the tool box during the procedure to prevent the plug from being connected by mistake.
- Be sure to wear insulating protective equipment consisting of gloves, shoes, face shield and glasses before beginning work on the high voltage system.
- Never allow workers other than the responsible person to touch the vehicle containing high voltage parts. To keep others from touching the high voltage parts, these parts must be covered with an insulating sheet except when using them.
- Refer to the ESM: **ELECTRIC POWER TRAIN > TRACTION MOTOR SYSTEM > FRONT TRACTION MOTOR > PRECAUTION > HIGH VOLTAGE PRECAUTIONS**

### **⚠ CAUTION**

- Never bring the vehicle into the READY status with the Service Plug removed unless otherwise instructed in the Service Manual. A malfunction may occur if this is not observed.
- Never remove plug and gasket of front traction motor. If they are removed by mistake, replace the gasket with a new one and install them.

### **IMPORTANT:**

- Before removing the negative cable of the 12 volt battery, write down any vehicle presets on the repair order.
- The trip meter display will be reset to zero (0), so make a note of current vehicle range as necessary.



1. Turn ON the power switch and move both front seats fully forward to allow space to access the Service Plug.
2. Turn OFF the power switch and then open the hood.
3. Close all doors except the hood, confirm that the combination meter is OFF, and then wait for at least 5 minutes.

**HINT:** If one of the vehicle's door locks is operated or a door is opened and closed during the 5 minutes, the waiting period will need to be repeated.

**IMPORTANT:** The Intelligent Key should always be stored away from the vehicle to prevent unintentional activation of the Approach Unlock, or accidental use by others while working.

4. Remove the vehicle's front lifting point covers (Figure 5), from both the driver (LH) side and passenger (RH) side, and then place the vehicle on a lift.
  - Set the lift, but do not raise the vehicle yet.

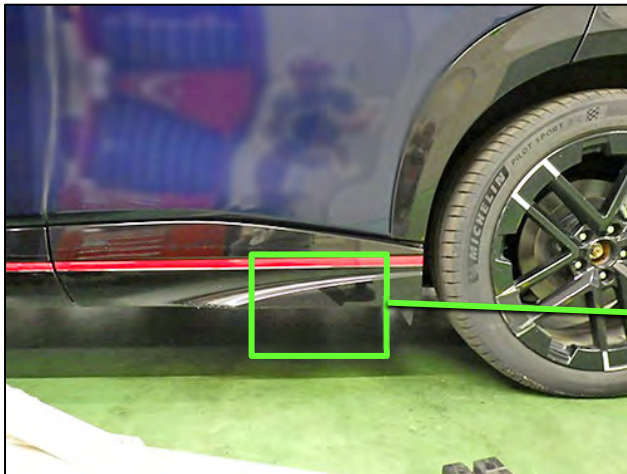

Figure 4

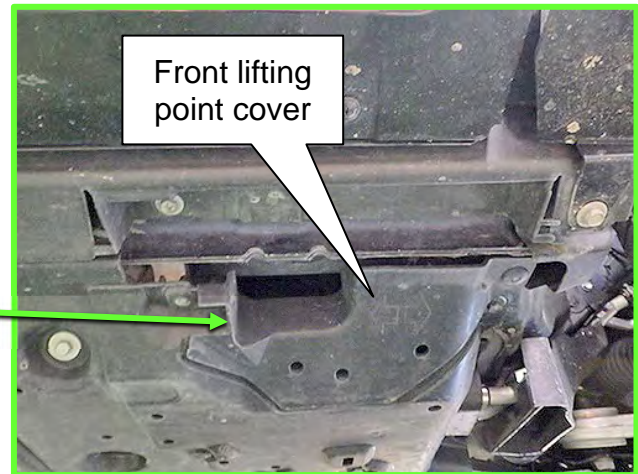

Figure 5

5. Disconnect both terminals of the 12 volt battery, negative first, and then remove the battery and both battery trays from the vehicle.
  - Refer to the **ESM: ELECTRICAL & POWER CONTROL > POWER SUPPLY, GROUND & CIRCUIT ELEMENTS > REMOVAL AND INSTALLATION > 12V BATTERY**

6. Disconnect the high voltage Service Plug (Figure 6).
  - Refer to the ESM: **GENERAL INFORMATION > GENERAL INFORMATION > PRECAUTIONS > CAUTIONS AS TO HIGH VOLTAGE > HOW TO DISCONNECT HIGH VOLTAGE : Precautions**

**⚠ WARNING**

To prevent personal injury:

- Wear insulating protective equipment.
- Immediately insulate removed high voltage connectors and terminals with insulating tape.
- Be sure to put the removed Service Plug in your pocket and carry it with you so that another person does not accidentally connect it while work is in progress.

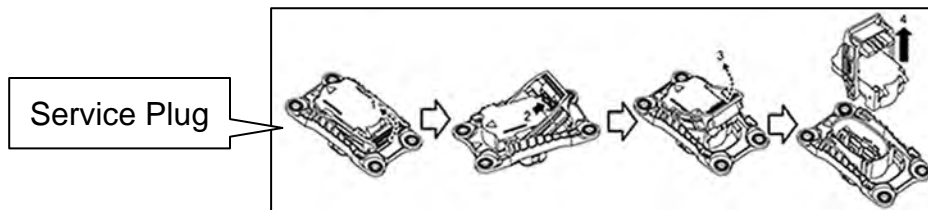

Figure 6

**⚠ WARNING**

Touching high voltage components without using the appropriate protective equipment will cause electrocution. Wear insulating protective equipment and wait at least 10 minutes after removing the Service Plug before starting the next task.

7. Check the High Voltage Circuit for voltage.
  - Refer to the ESM: **GENERAL INFORMATION > GENERAL INFORMATION > PRECAUTIONS > CAUTIONS AS TO HIGH VOLTAGE > CHECK VOLTAGE IN HIGH VOLTAGE CIRCUIT : Precautions**

# REMOVAL OF THE FRONT DRIVE MOTOR, INVERTER, AND REDUCTION GEAR WITH THE FRONT SUSPENSION MEMBER

8. Remove the driver (LH) side powertrain coolant reservoir cap.

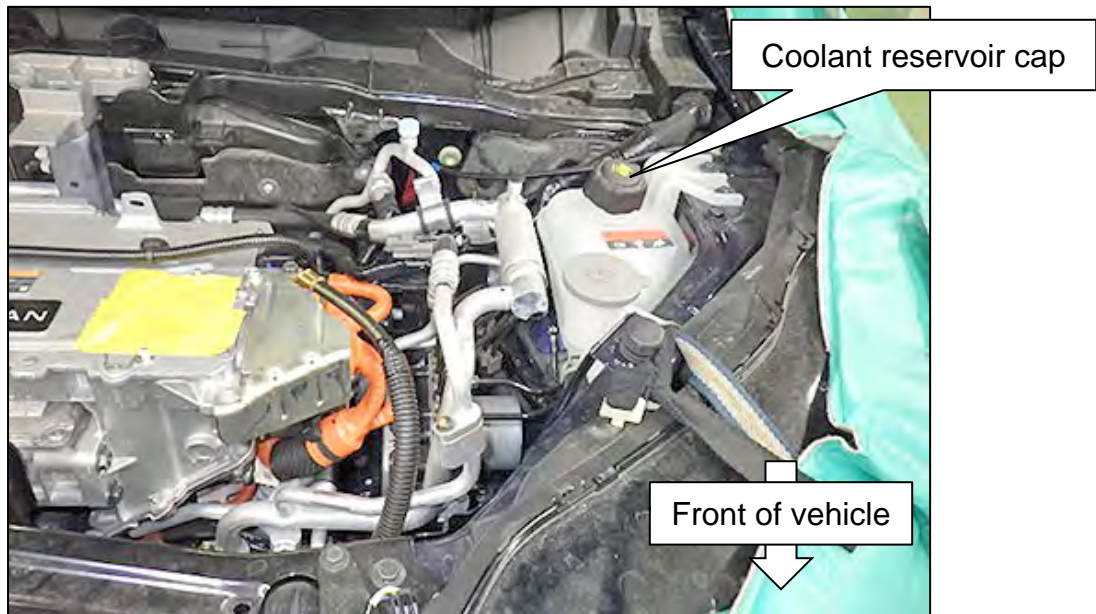

Figure 7

9. Raise the vehicle to a level so that the undercovers can be removed.
10. Remove the Front Under Cover Front and Front Under Cover Rear.

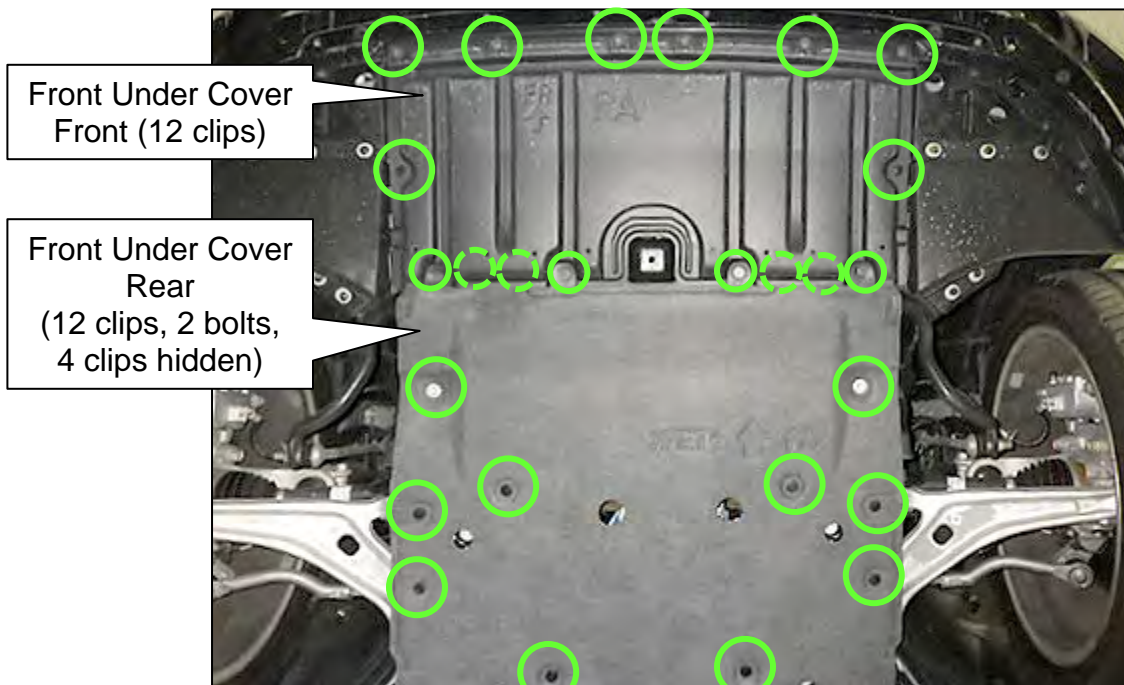

Figure 8



11. Remove the seven (7) plastic clips and twelve (12) bolts of the Li-ion Battery Under Cover (Front), and then remove the Li-ion Battery Under Cover (Front).

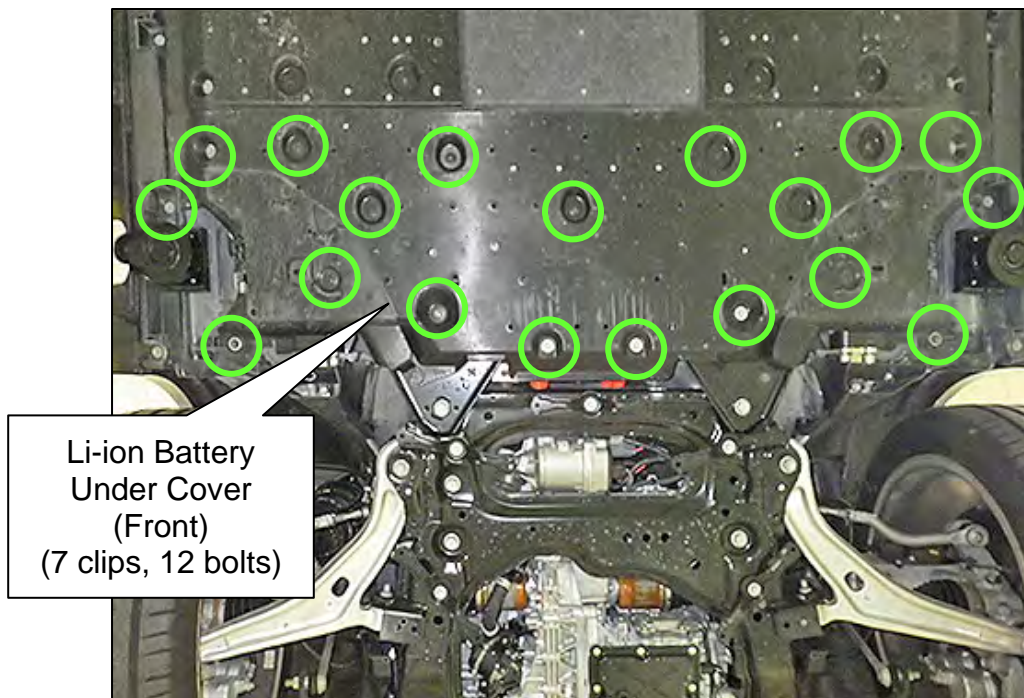

Figure 9

12. Remove the cooling system drain plug and drain the coolant into an appropriate container.

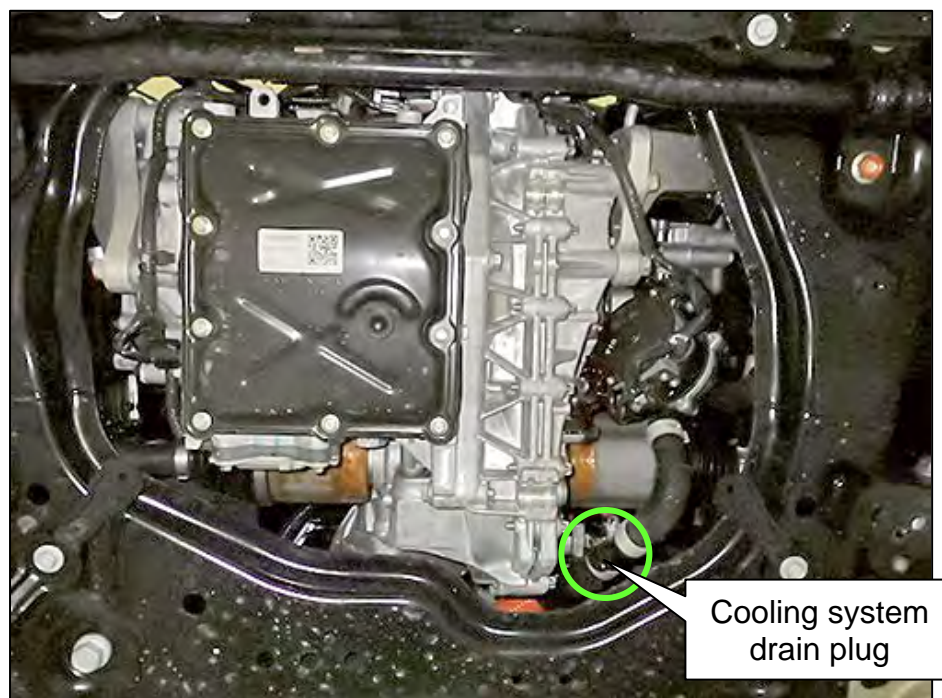

Figure 10



13. With the cooling system drain plug still removed, place the container on the floor under the drain and lower the vehicle to a comfortable level to access components under the hood.

**⚠ WARNING**

Never remove the reservoir tank cap if the drive motor or other high voltage part is hot. Hot coolant may spout out from the radiator, causing serious injury.

14. Wrap the Reservoir Tank outlet with a shop towel and gradually apply air pressure to the driver (LH) side coolant Reservoir Tank (for electric powertrain) to remove any remaining coolant from the system.

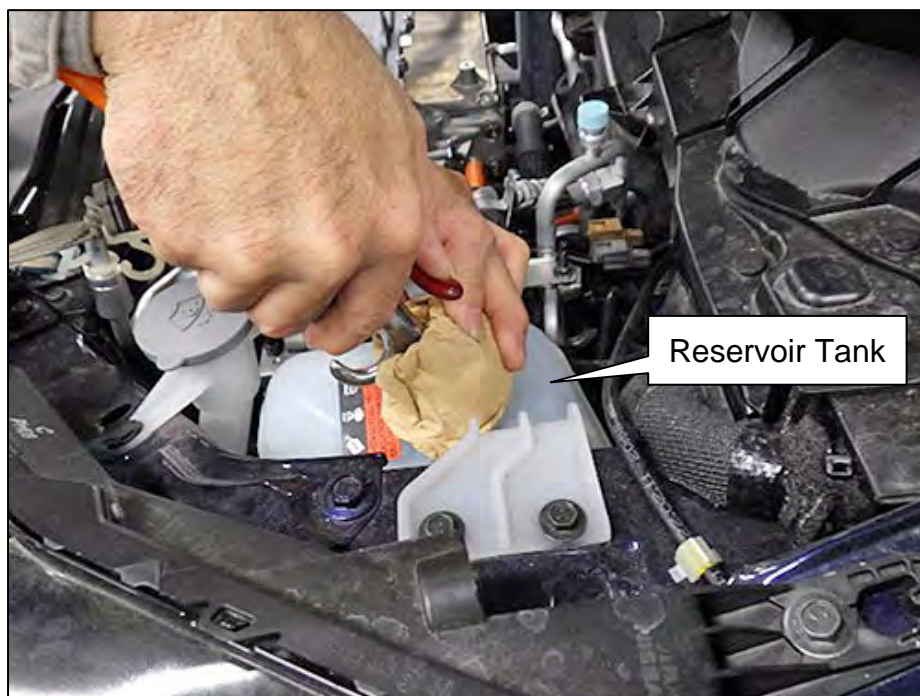

Figure 11

15. Raise the vehicle and then clamp the Radiator Hose Lower of the Electric Water Pump with hose pinch-off pliers.

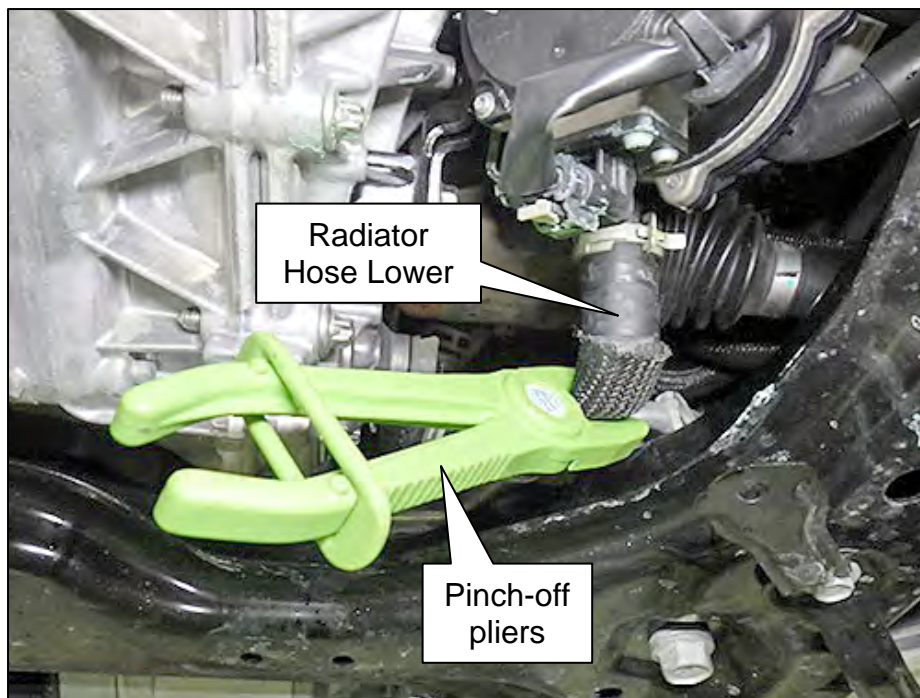

Figure 12

16. Lower the vehicle.
17. With the Reservoir Tank outlet still wrapped with the shop towel, blow air into the Reservoir Tank again as shown in Figure 11.
18. Raise the vehicle and remove the hose pinch-off pliers from the Radiator Hose Lower that were applied in step 15.
19. Lower the vehicle.
20. Blow air into the Reservoir Tank a third time as shown in Figure 11.
21. Raise the vehicle.
22. Replace the Drain Plug O-ring with a new one, and then reinstall the drain plug.

- Discard the removed O-ring.
- Refer to **PARTS INFORMATION** on page 110.
- Torque Drain Plug to 1.17 N•m (0.12 kg-m, **10 in.-lbs**)



Figure 13

23. Lower the vehicle.
24. Remove the High Voltage Power Delivery Assembly.
  - Refer to the ESM: **ELECTRIC POWER TRAIN > VEHICLE CHARGING SYSTEM > REMOVAL AND INSTALLATION > HIGH VOLTAGE POWER DELIVERY ASSEMBLY > HIGH VOLTAGE POWER DELIVERY ASSEMBLY : Removal & Installation**

**⚠ DANGER**

Since hybrid vehicles and electric vehicles contain a high voltage battery, there is the risk of electric shock, electric leakage, or similar accidents if the high voltage component and vehicle are handled incorrectly. To avoid death be sure to follow the correct work procedures when performing inspection and maintenance.

- Refer to the ESM: **ELECTRIC POWER TRAIN > TRACTION MOTOR SYSTEM > FRONT TRACTION MOTOR > PRECAUTION > HIGH VOLTAGE PRECAUTIONS**



25. Remove the High Voltage Harness Cover from the Inverter High Voltage Harness.
- Eight (8) bolts.

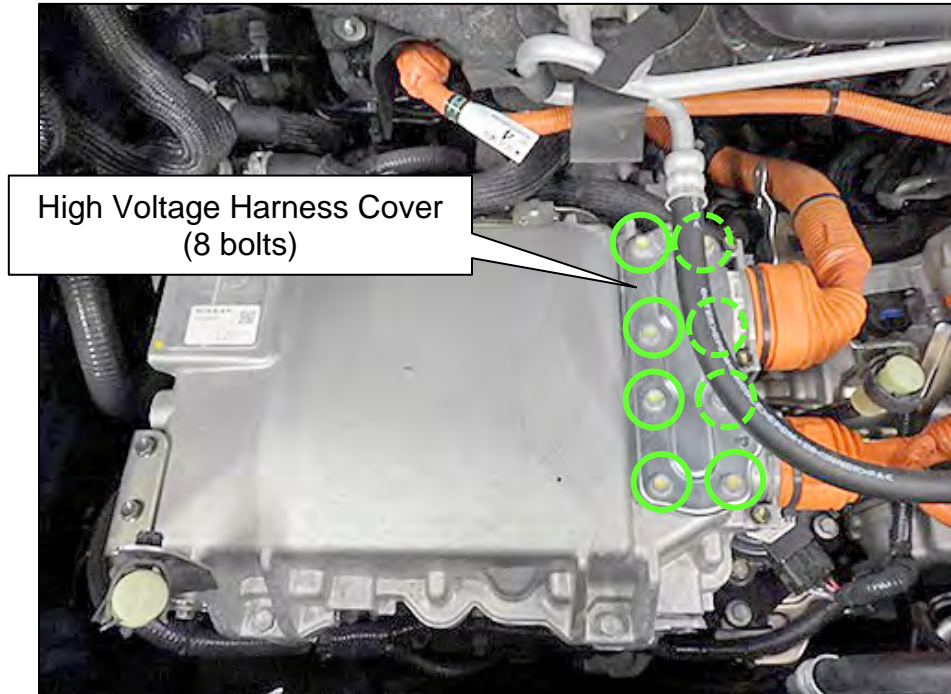

Figure 14

26. Remove the four (4) bolts that connect the Front High Voltage Harness to the Inverter.

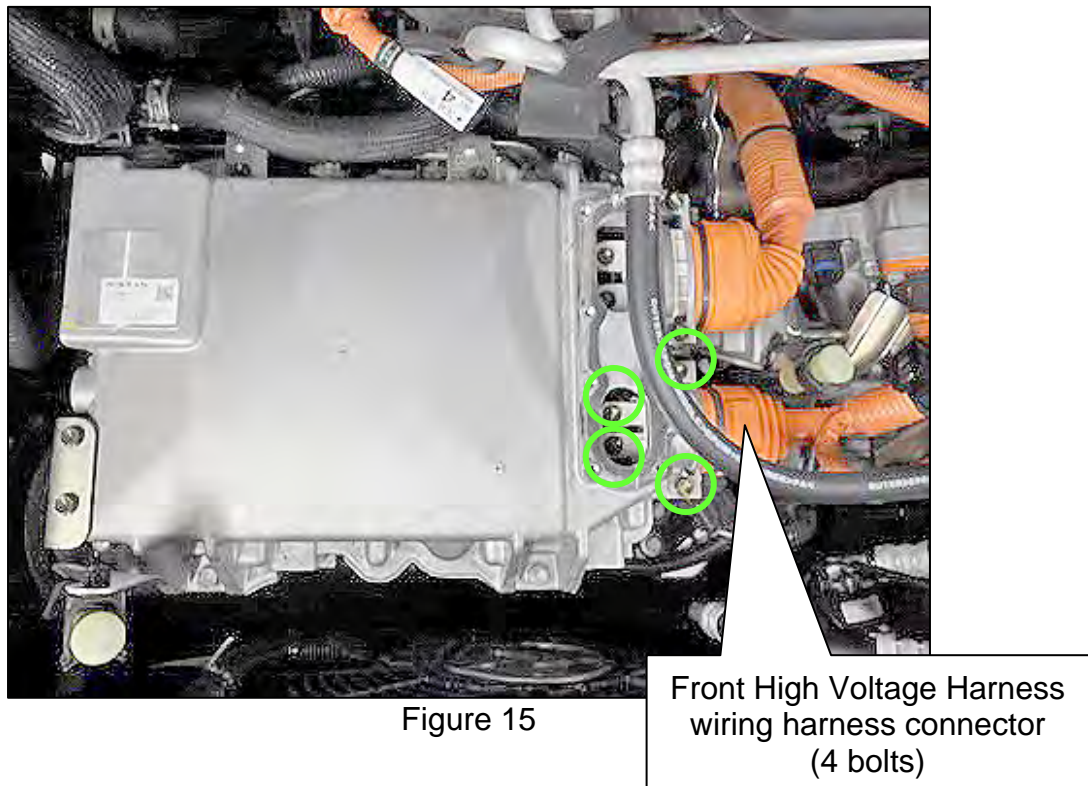

Figure 15

27. Detach the two (2) Front High Voltage Harness wiring harness clips.
28. Unplug the Front High Voltage Harness wiring harness connectors from the Inverter and the Air Conditioner's Electric Compressor.
29. Apply protective tape to cover all high voltage harness plug ends.

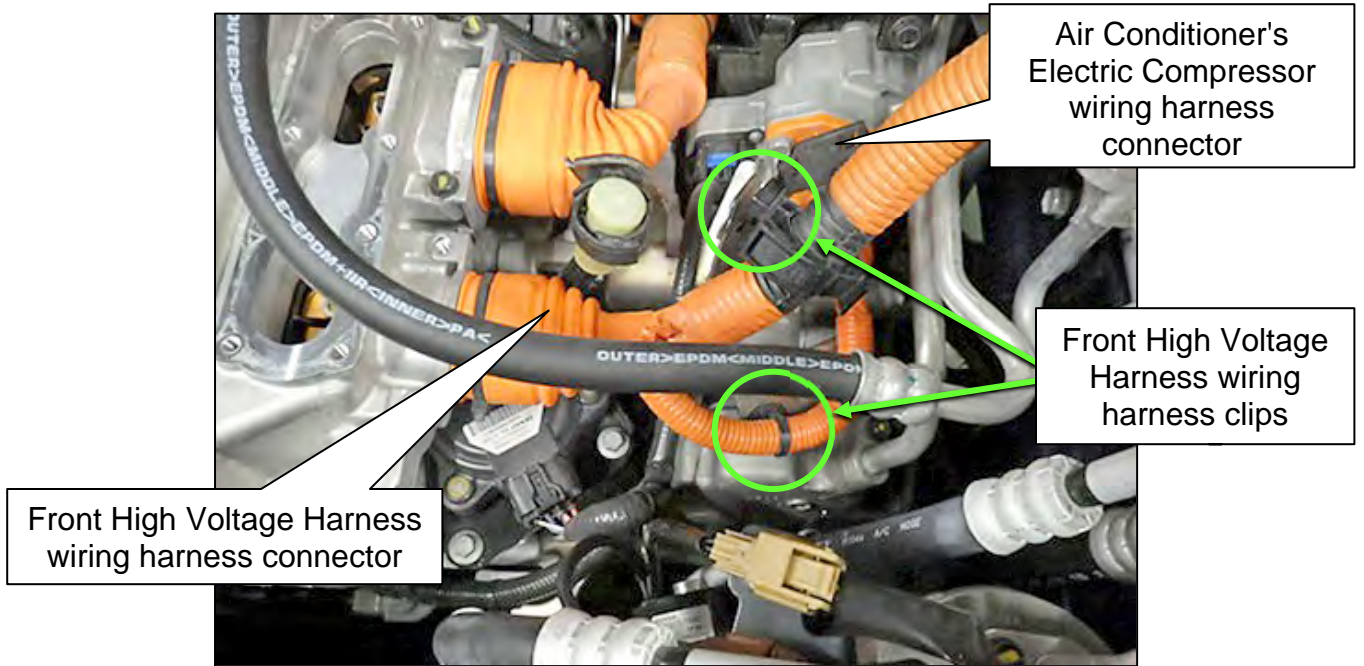

Figure 16

30. Remove the Front High Voltage Harness from the vehicle.
31. Remove the four (4) bolts that connect the Rear High Voltage Harness connector to the Inverter, and then remove the connector from the Inverter.

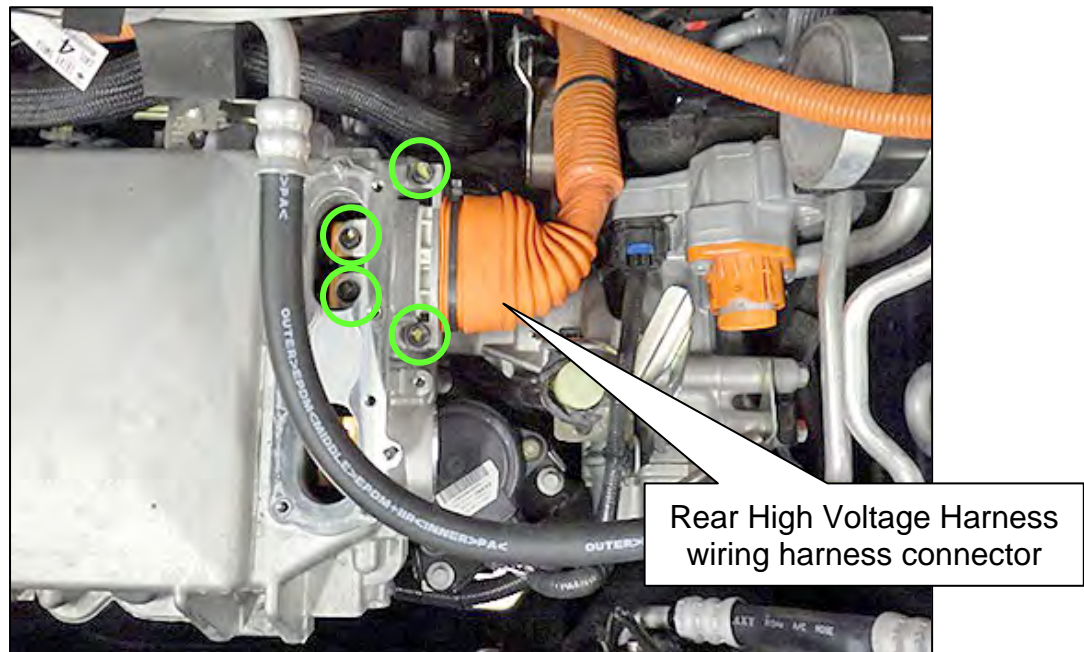

Figure 17



32. Apply protective tape to cover the high voltage harness plug ends and the high voltage sockets (Figure 18).
33. Apply protective tape to cover the high voltage connections of the Inverter.



Figure 18

34. Remove the bolt securing the Rear High Voltage Harness.
35. Disconnect the Electronic Power Steering (EPS) harness retainer from the Rear High Voltage Harness bracket.

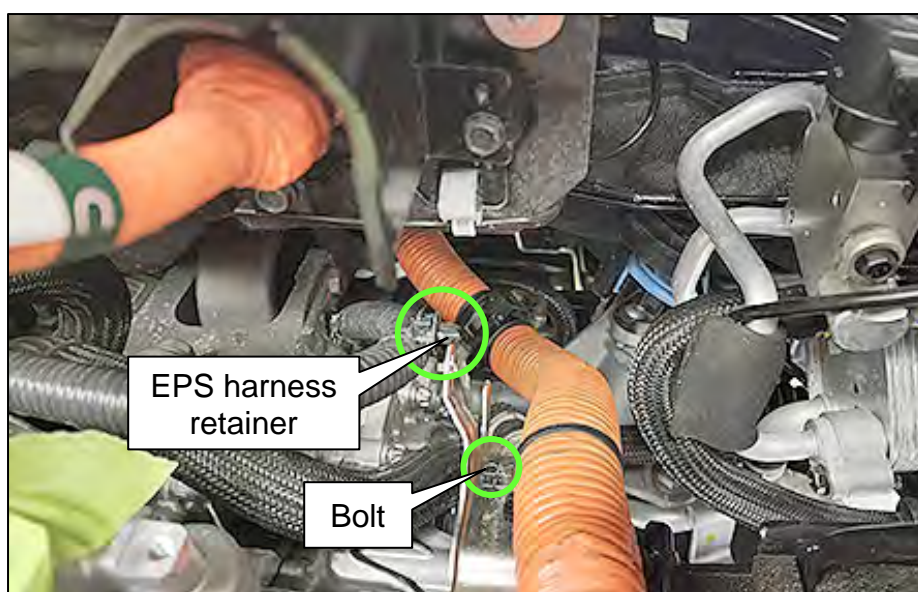

Figure 19



36. Detach the Rear High Voltage Harness clip.



Figure 20

37. Secure the Rear High Voltage Harness connector to the cowl top.

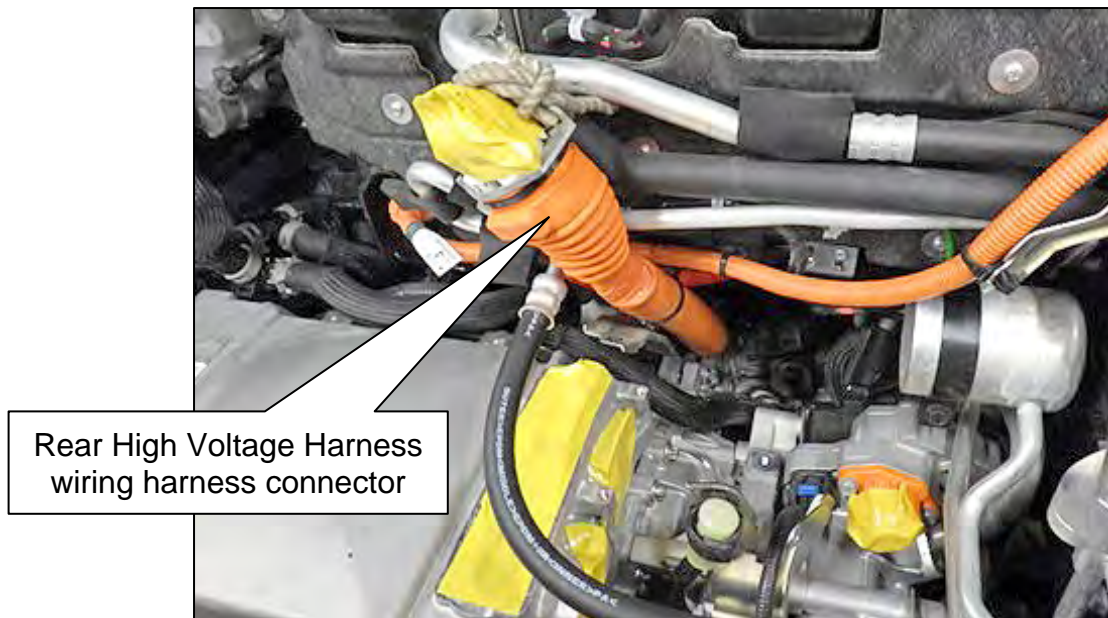

Figure 21

## Removal of the Air Conditioner's Electric Compressor from Traction Motor

38. Place an index mark across the High-Pressure Flexible Hose's "surge tank" and its bracket.

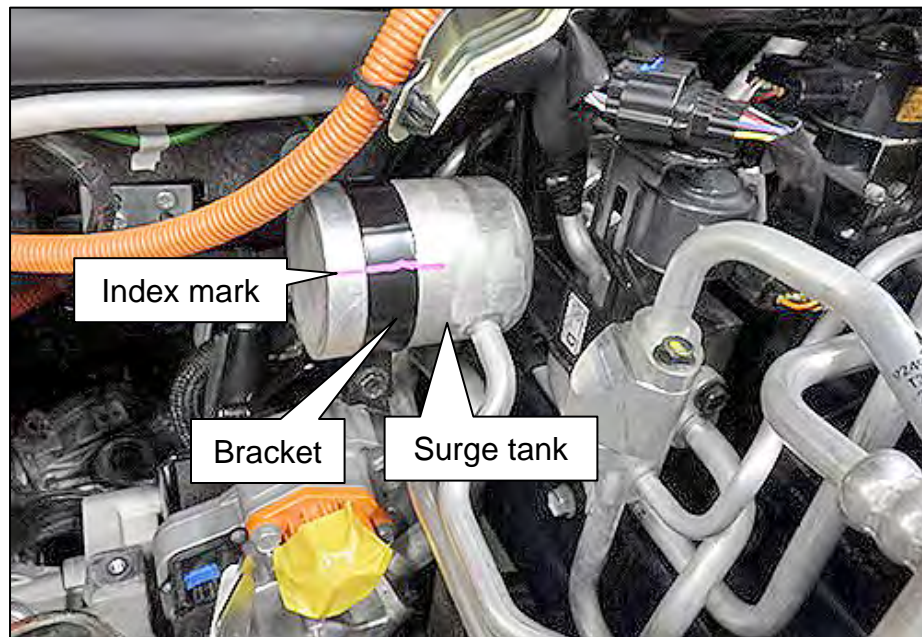

Figure 22

39. Remove the Surge Tank bracket's bolts, and then the Surge Tank bracket.
- Two (2) bolts.

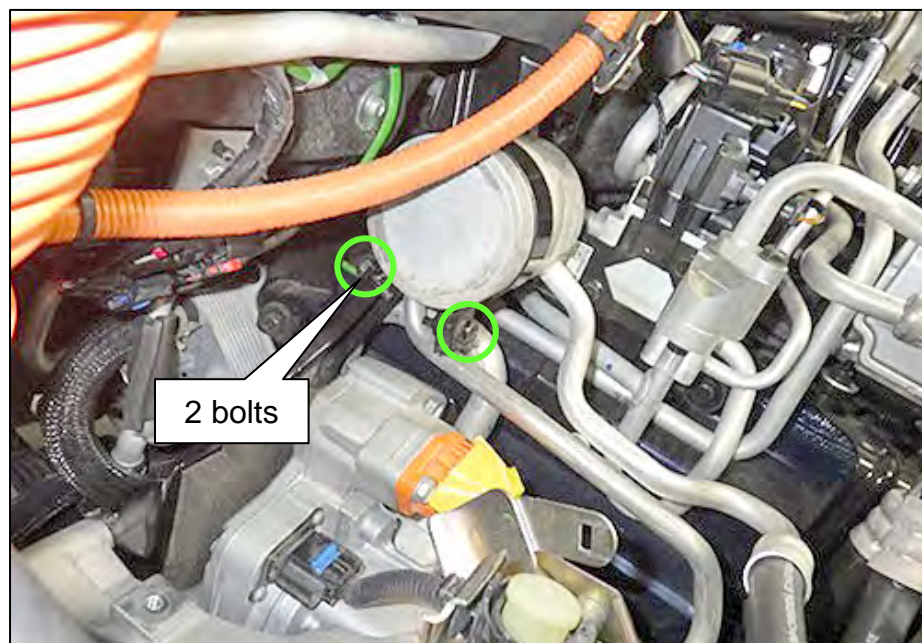

Figure 23



40. Disconnect the wiring harness connector of the Electric Compressor.

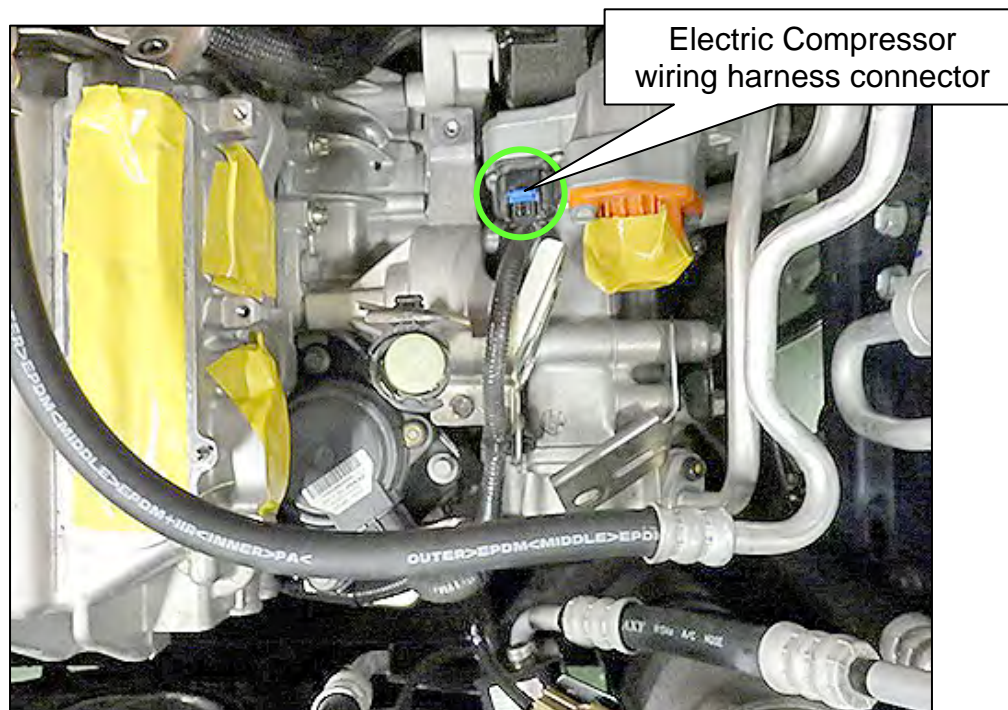

Figure 24

41. Raise the vehicle to a comfortable level to remove both front wheel and tire assemblies.
42. Remove both front wheel and tire assemblies.
43. Remove the driver (LH) side Air Guide (Figure 25).
  - Seven (7) screws and two (2) clips.

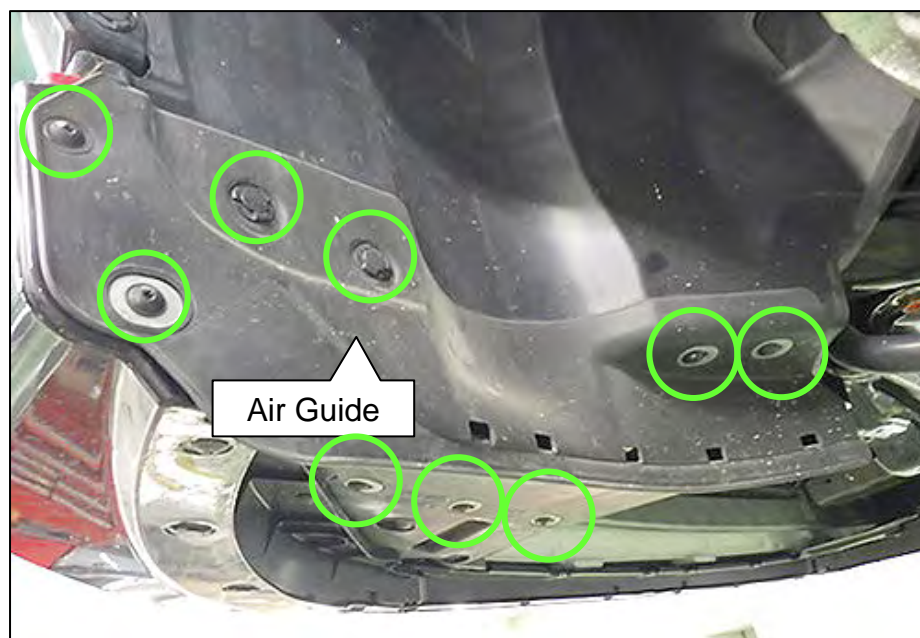

Figure 25



44. Remove the eight (8) screws that attach the front lower side of the driver (LH) side Fender Protector.

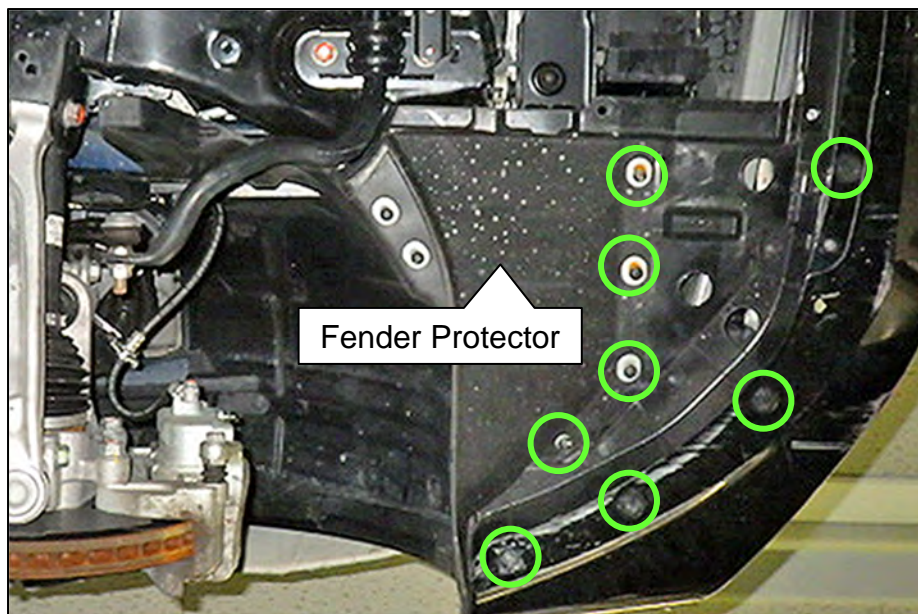

Figure 26

45. Remove the eight (8) clips that retain the Fender Protector and then move the Fender Protector down and towards the rear of the vehicle.

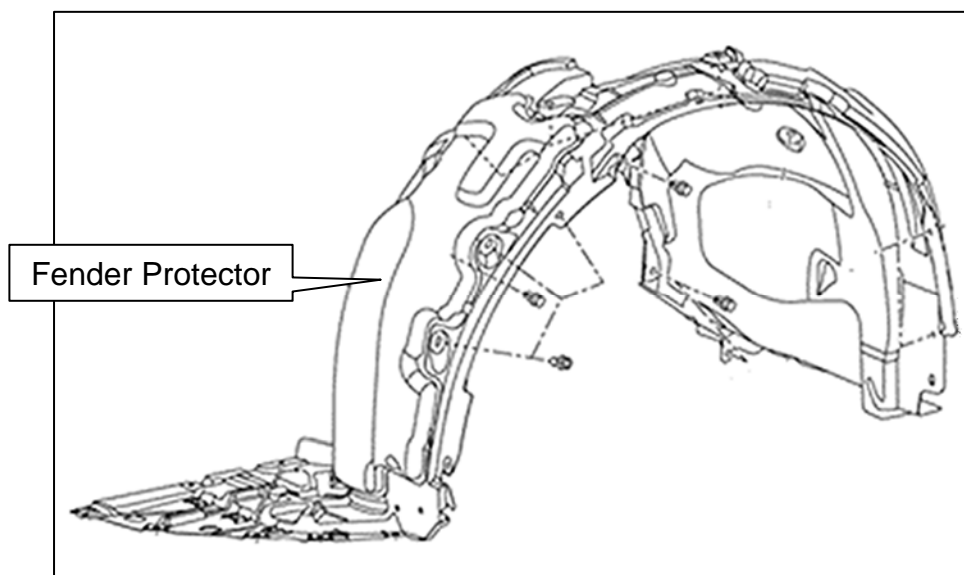

Figure 27

- Secure the Fender Protector out of the way with an appropriate retention device as shown in Figure 28 on page 19.

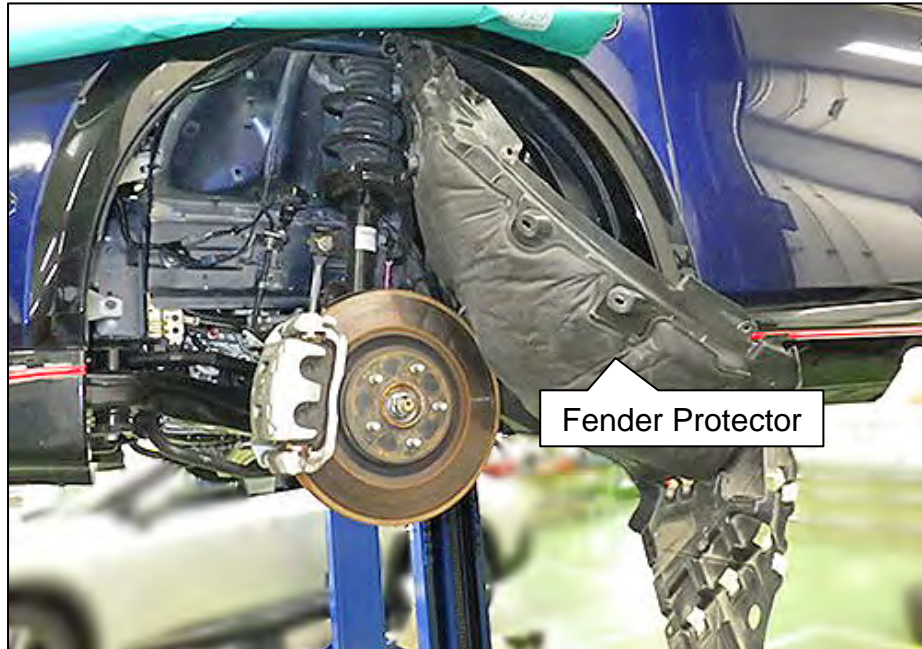

Figure 28

46. Disconnect the ground cable from the Front Traction Motor, and then move it out of the way.
- One (1) bolt.

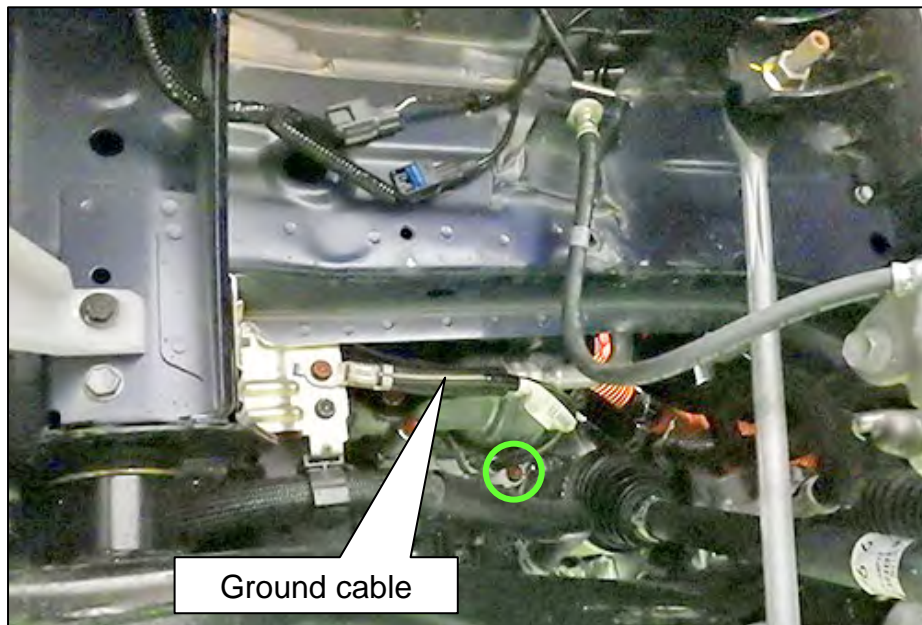

Figure 29



47. Remove the four (4) Compressor Stay mounting bolts from the air conditioning Electric Compressor.

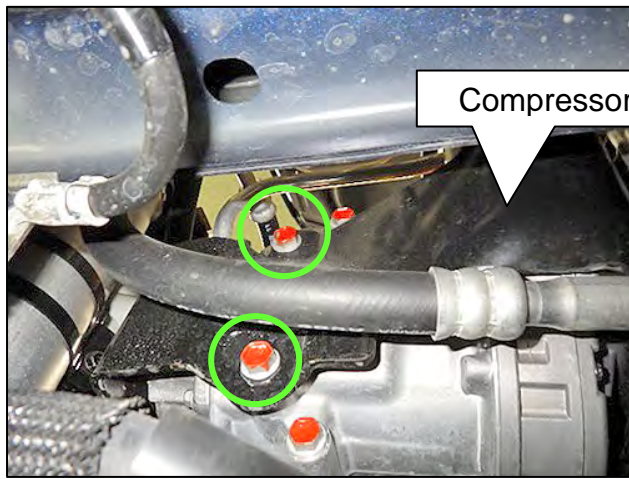

Figure 30

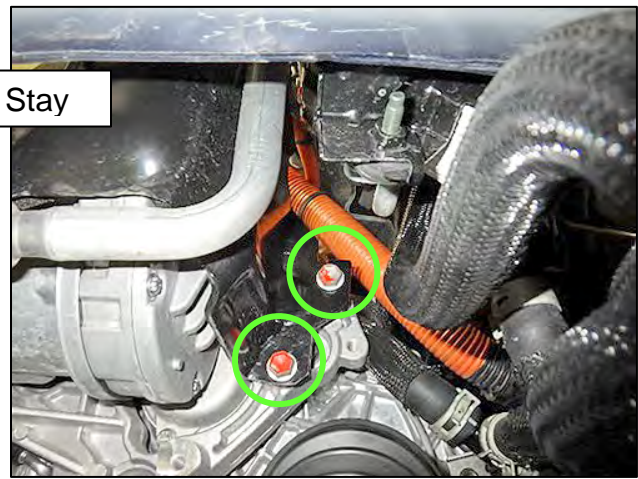

Figure 31

48. Slide the Compressor Stay to the rear of the vehicle to access the Electric Compressor mounting bolts.
49. Remove the two (2) lower mounting bolts of the Electric Compressor (Figure 32).

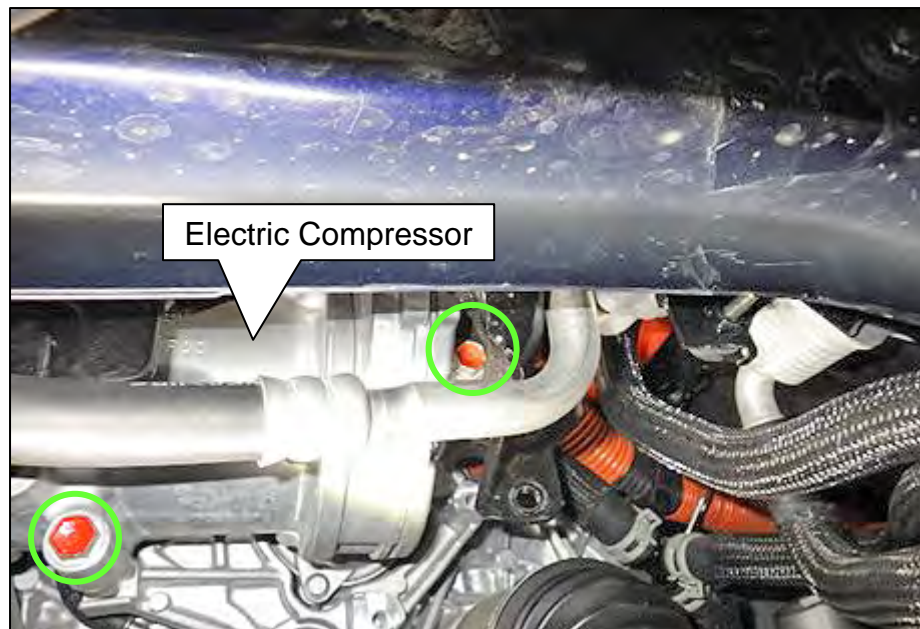

Figure 32



50. Lower the vehicle to work under the hood.
51. Slide the Compressor Stay out of the way, and then remove the upper mounting bolt of the Electric Compressor.

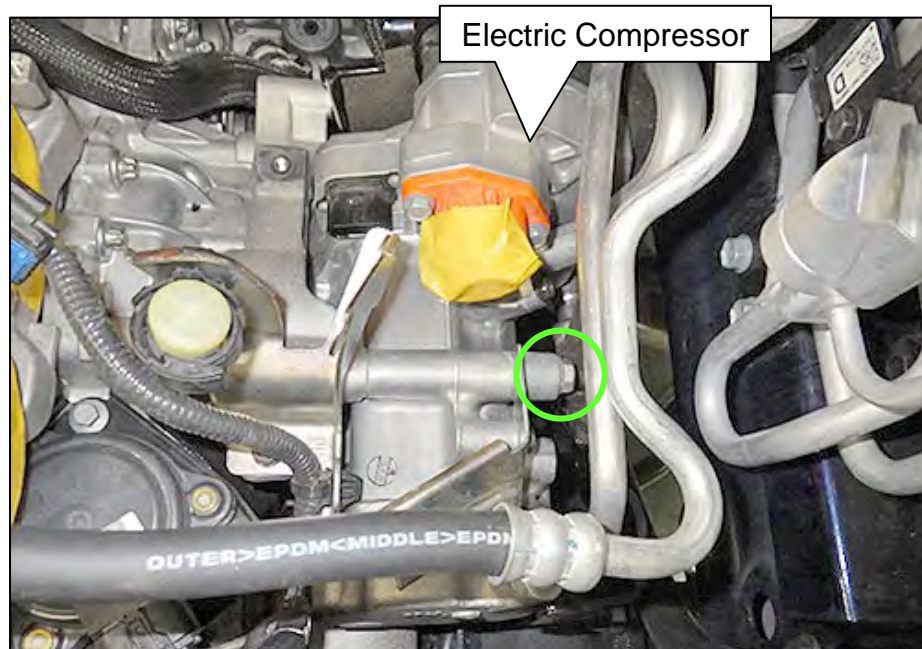

Figure 33

52. Secure the Electric Compressor to the cowl top with an appropriate retention strap, so that it is out of the way.

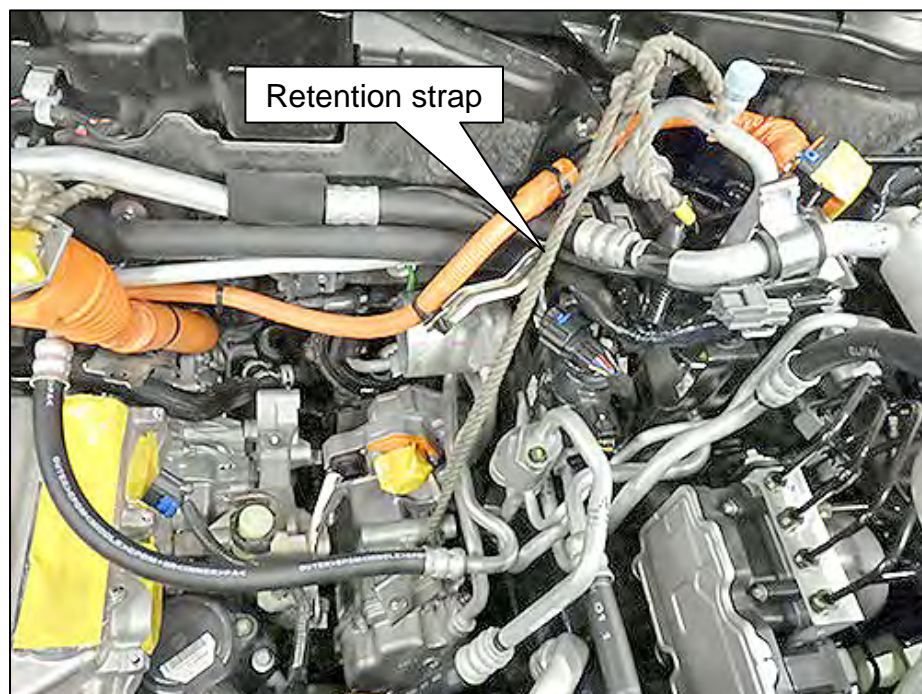

Figure 34

## Remove the Passenger (RH) Side Reservoir Tank

53. Remove the passenger (RH) side coolant Reservoir Tank (for Li-ion battery).
  - One (1) bolt.

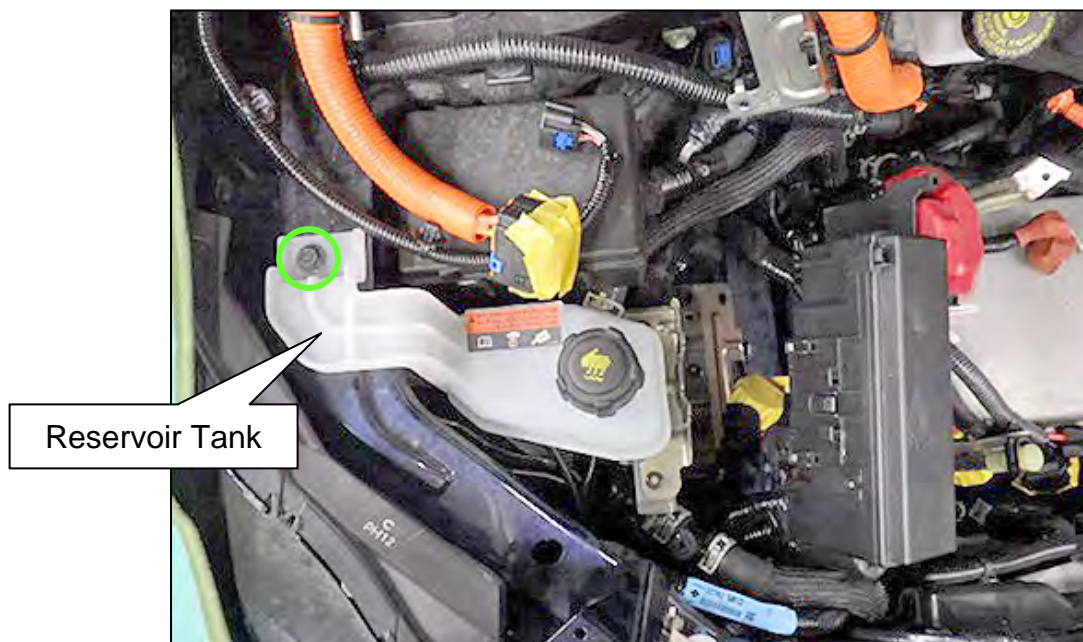

Figure 35

54. Move the Reservoir Tank so that it rests on top of the Inverter.
55. Place the Reservoir Tank in a small pan or tray to collect any spilled coolant.

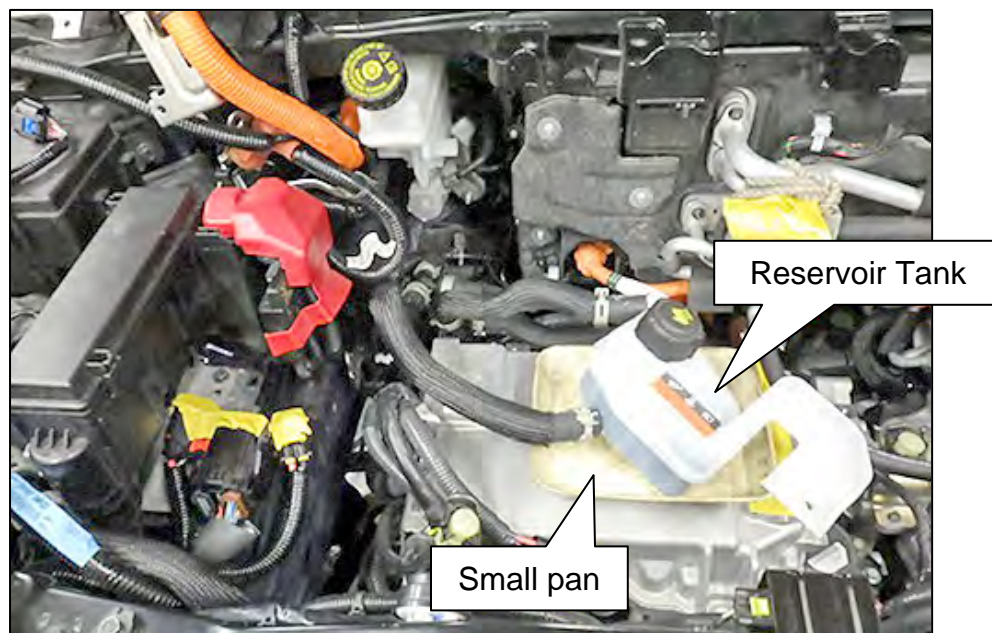

Figure 36



## Disconnect the Wiring Harness Connectors on the Passenger (RH) Side Harness

56. Detach the wiring harness from its bracket where shown in Figure 37.

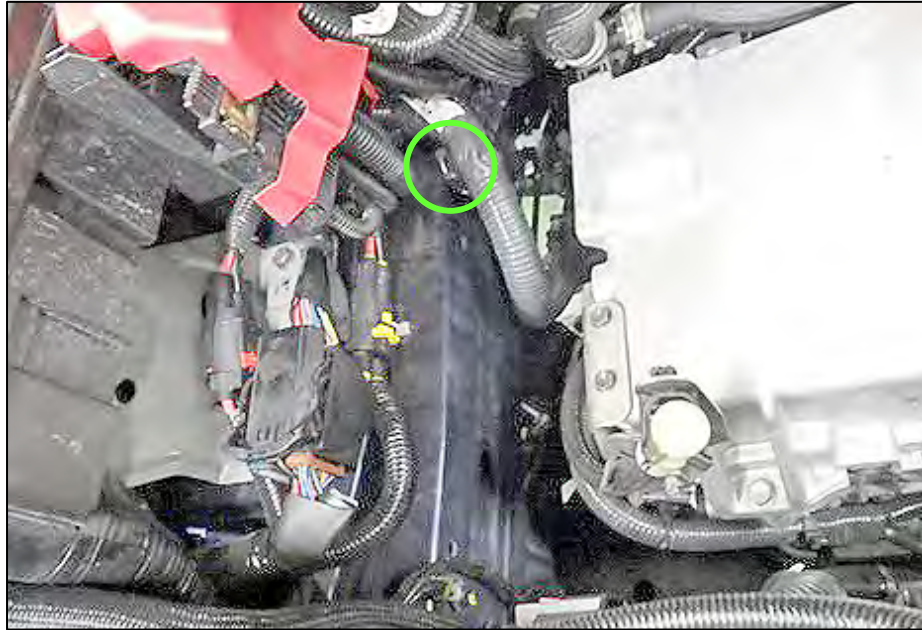

Figure 37

57. Disconnect three (3) wiring harness connectors (shown in Figure 38 below and Figure 40 on page 24).
- Push the upper two (2) wiring harness connectors toward the rear of the vehicle to release them from the bracket, and then disconnect the two (2) upper connectors.

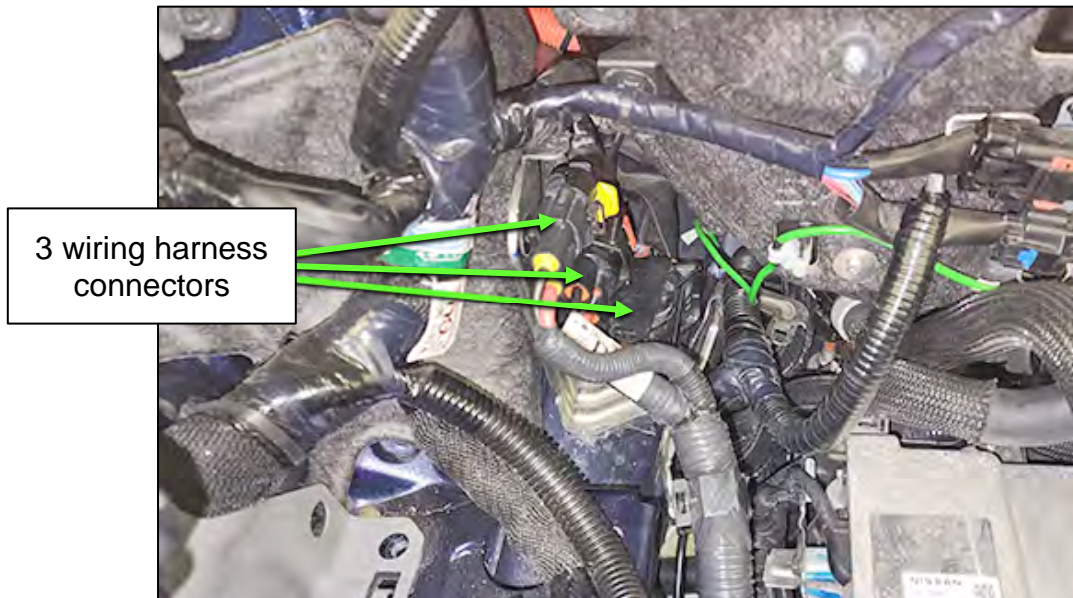

Figure 38

b. Disconnect the lower wiring harness connector.

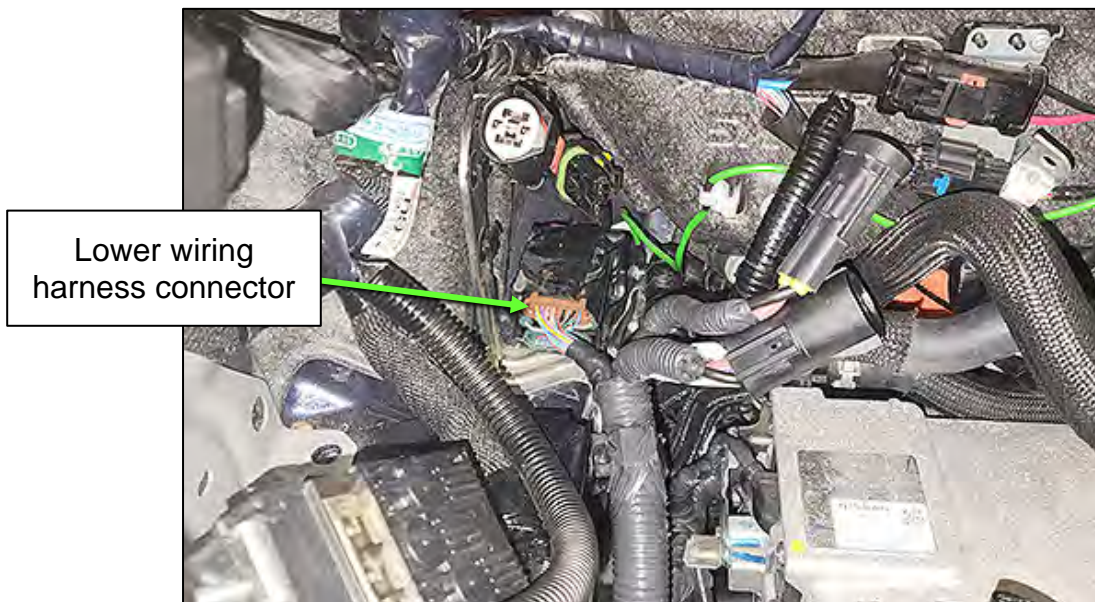

Figure 39

58. Apply protective tape to cover the wiring harness plug ends and the high voltage sockets.

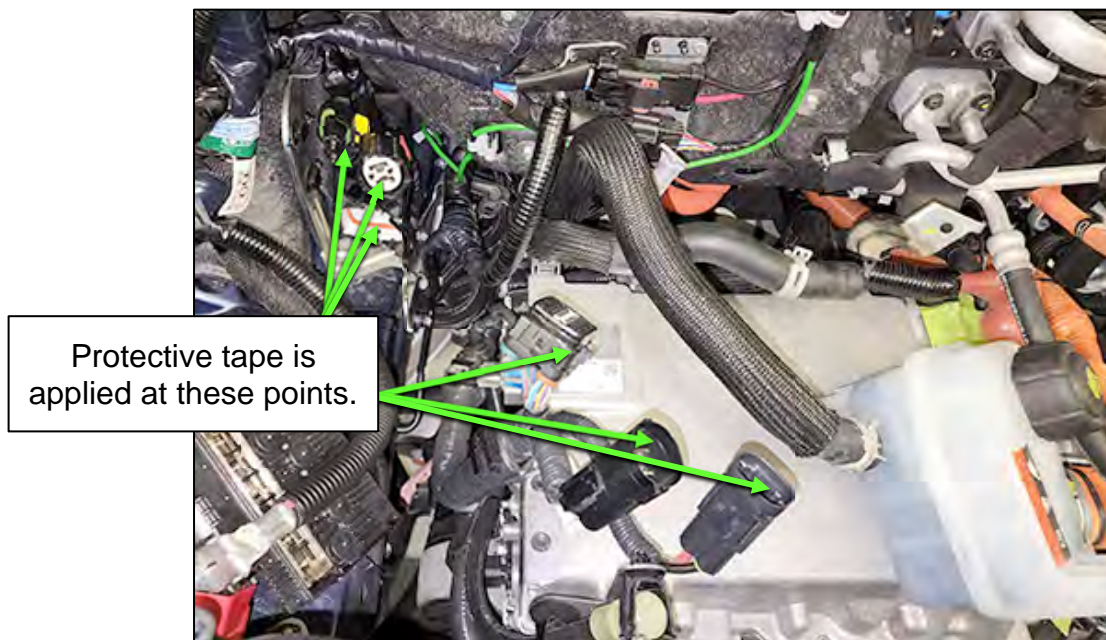

Figure 40



59. Disconnect the reservoir hose 3-way connector from its bracket.

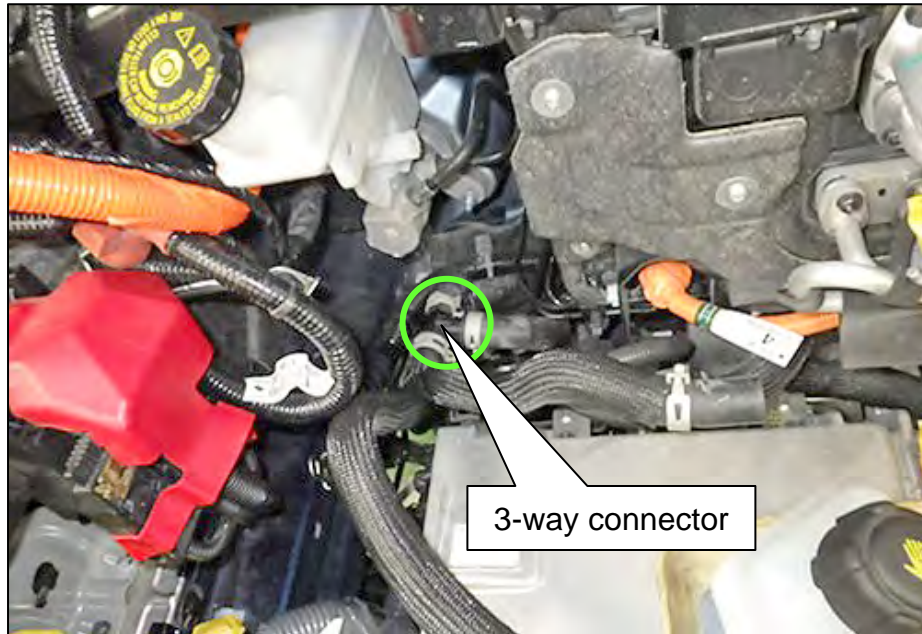

Figure 41

60. Secure the steering wheel so that it cannot turn.

61. Remove the Steering Shaft Lower Cover.

- Two (2) clips.



Figure 42

62. Disconnect the lower steering joint.
  - a. Mark the lower joint so that it can be reassembled in the same orientation.
  - b. Remove one (1) pinch bolt.
  - c. Disconnect the lower steering joint from the steering rack.

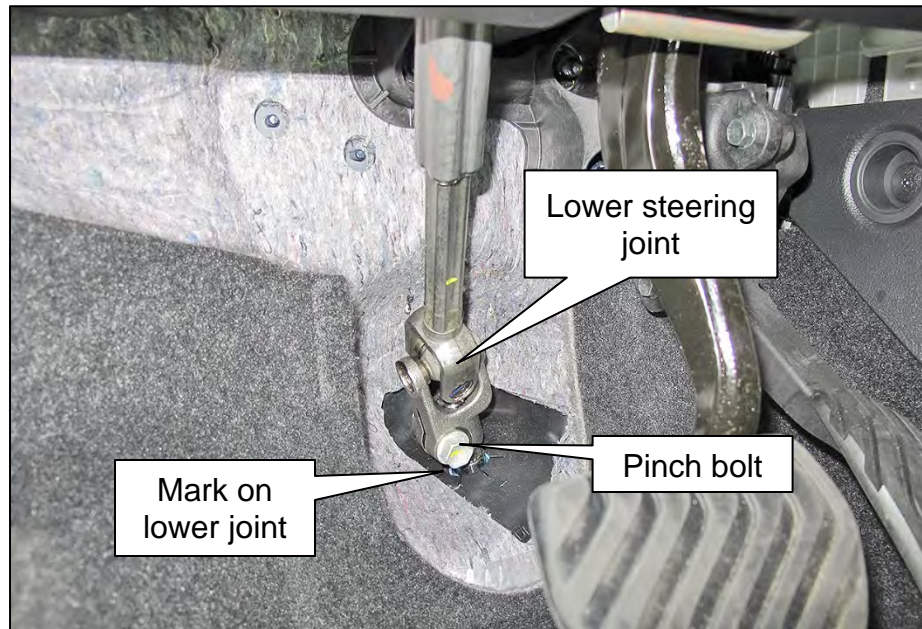

Figure 43

### Remove the Right Drive Shaft From the Steering Knuckle Assembly

63. Remove the passenger (RH) side Air Guide (Figure 44).
  - Seven (7) screws and two (2) clips.

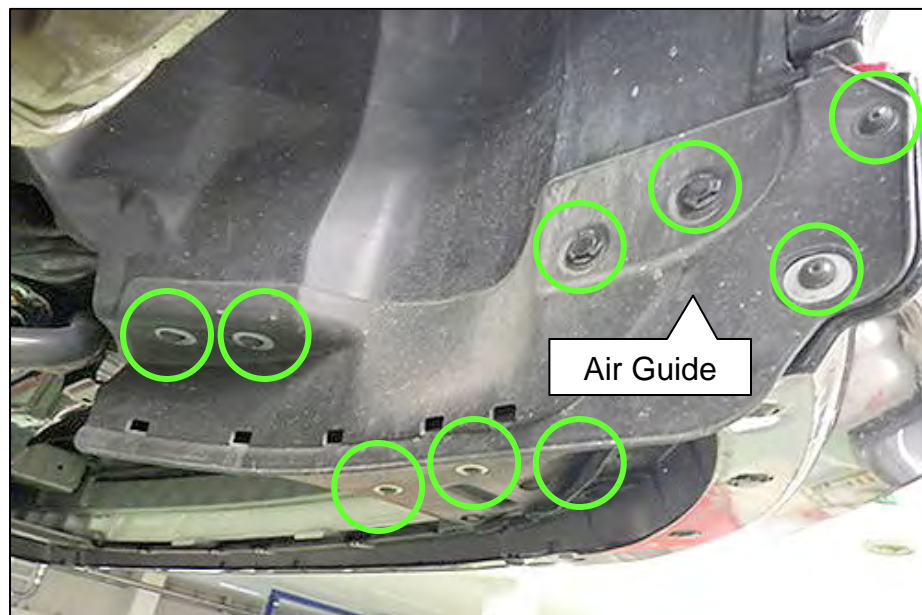

Figure 44



64. Remove the eight (8) screws that attach the front lower side of the passenger (RH) side Fender Protector.

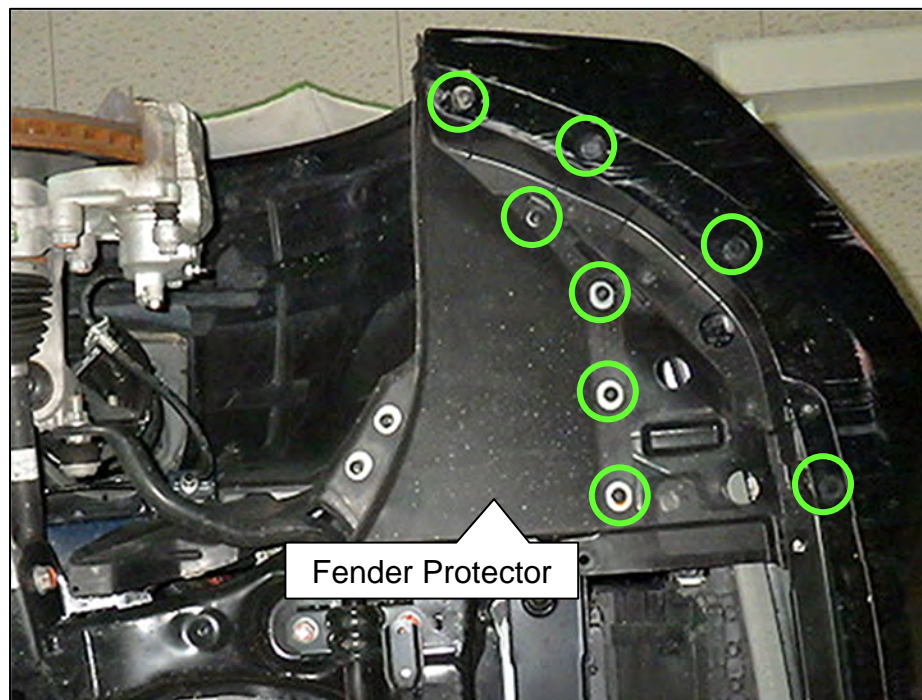

Figure 45

65. Remove the eight (8) clips that retain the Fender Protector, and then move the Fender Protector down and towards the rear of the vehicle.

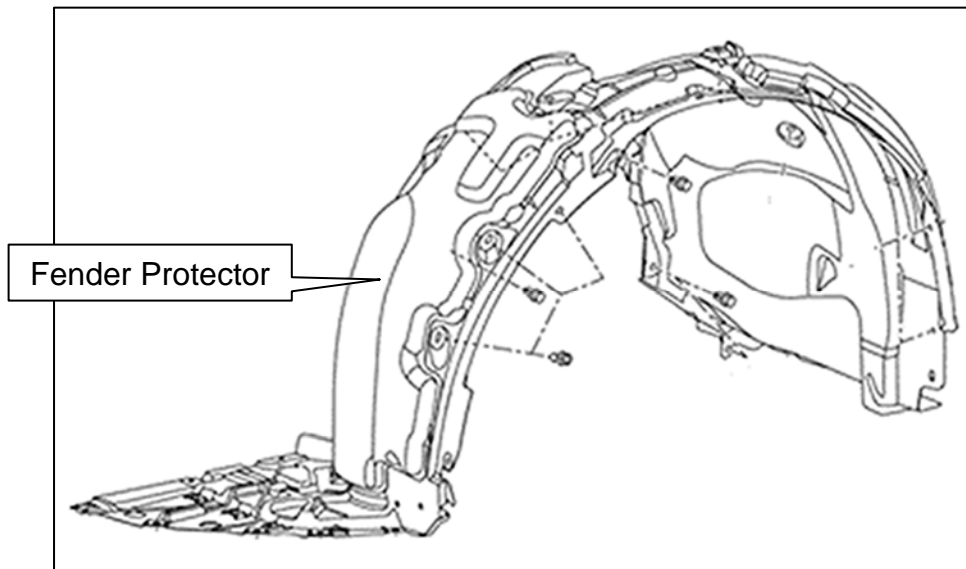

Figure 46



- Secure the Fender Protector out of the way with an appropriate retention device.

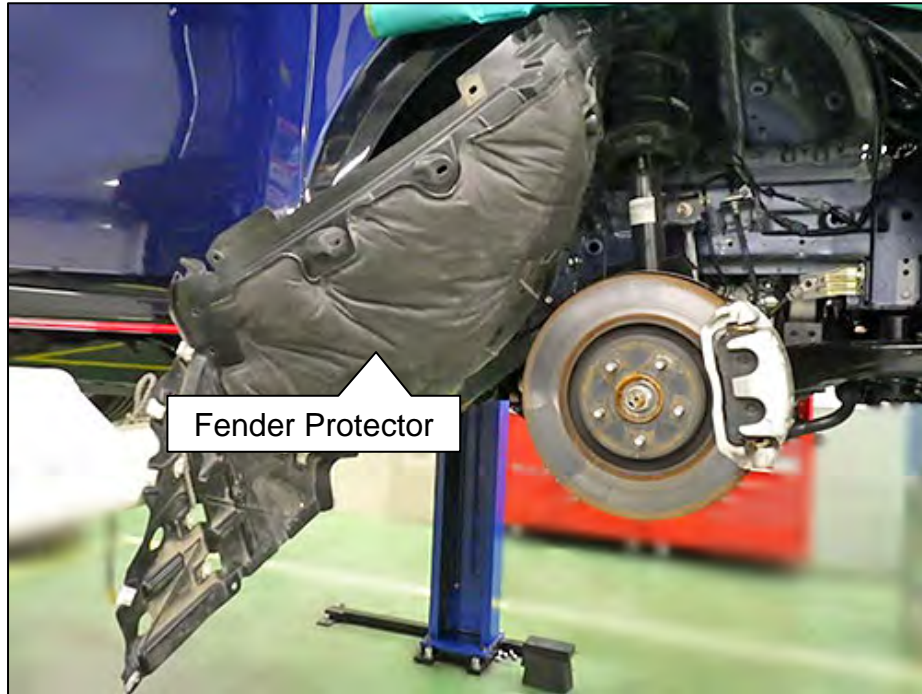

Figure 47

66. Disconnect the ground cable on the passenger (RH) side of the Traction Motor, and then move it out of the way.

- One (1) bolt.



Figure 48

67. Remove the passenger (RH) side Wheel Speed Sensor wiring harness from supports.
  - a. Remove the grommet from the bracket.
  - b. Remove the bolt.

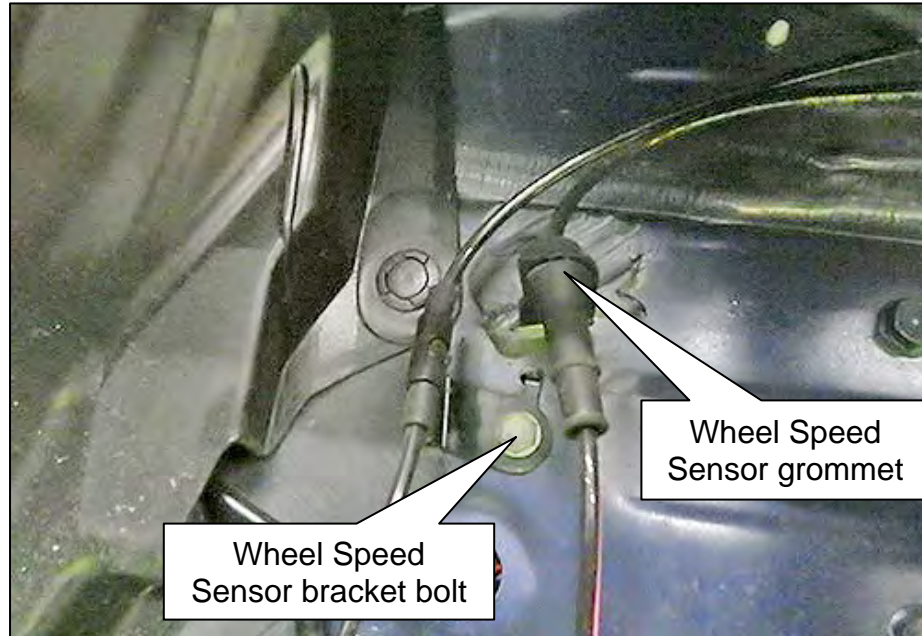

Figure 49

68. Remove the brake hose lock plate from the bracket.

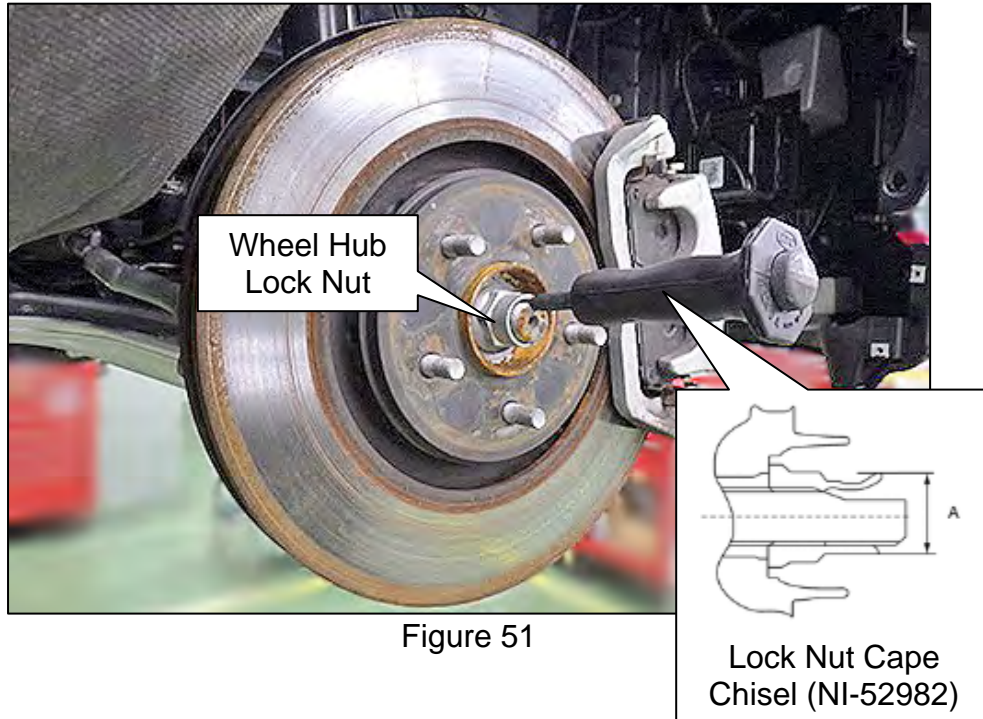

Figure 50



69. Remove the Wheel Hub Lock Nut from the passenger (RH) side Front Drive Shaft.
- Use Lock Nut Cape Chisel (NI-52982) to release the Wheel Hub Lock Nut from the Front Drive Shaft.

**HINT:** The crimping part (A) of the Wheel Hub Lock Nut should be 31 mm or more wide.



70. Remove the steering Outer Socket from the Steering Knuckle.

**NOTICE**

Use a ball joint remover to prevent damage to the joint's rubber boot.

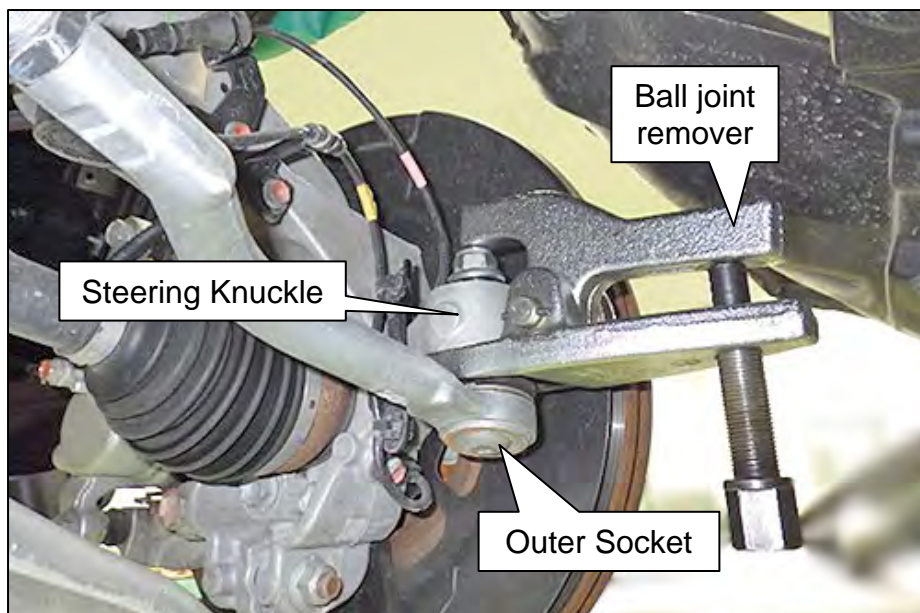



71. Disconnect the Stabilizer Connecting Rod from the Stabilizer Bar Assembly.
- One (1) nut.

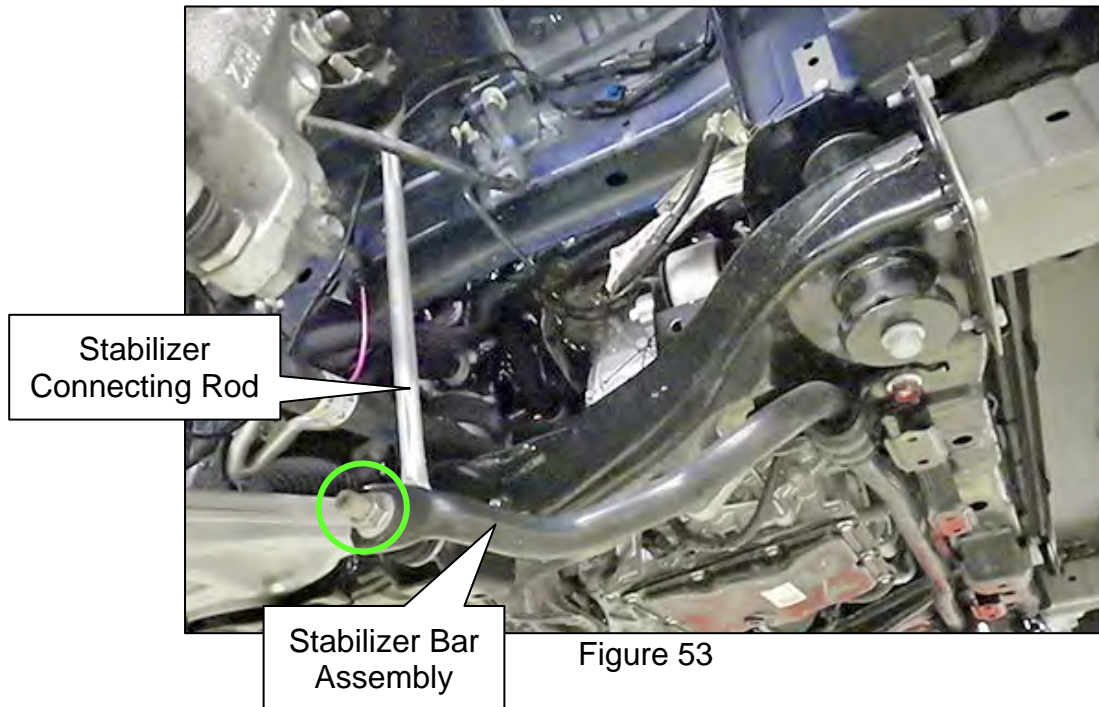

72. Unbolt the Transversal Link from the Front Suspension Member.
- Two (2) nuts and bolts.

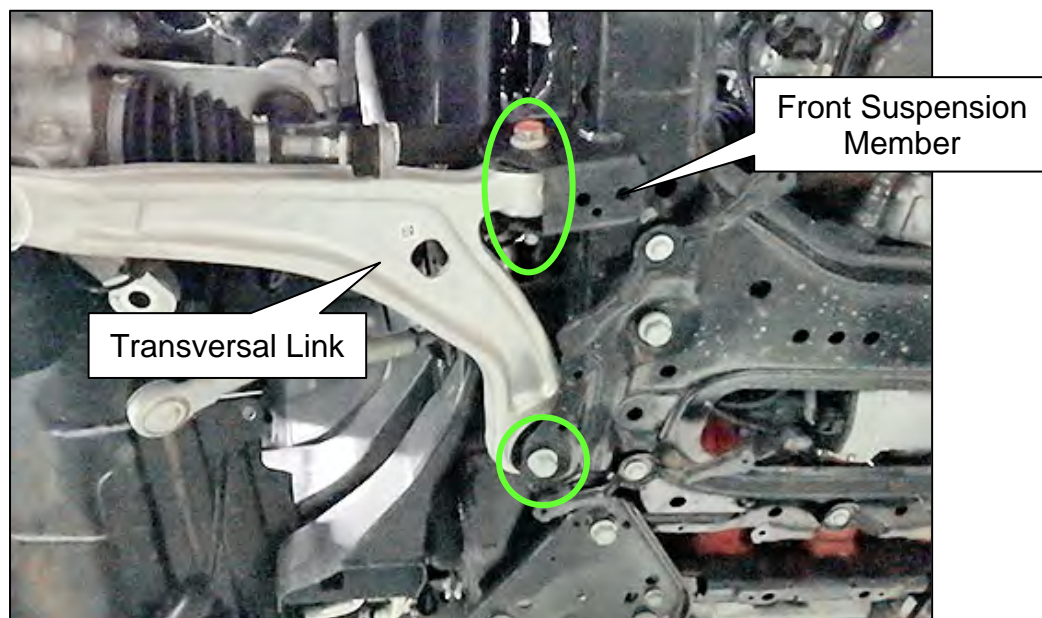

73. Remove the Front Drive Shaft from the Steering Knuckle and position it behind the Steering Knuckle.

**HINT:** Front Drive Shafts will NOT be removed from the reduction gear assembly for this repair.

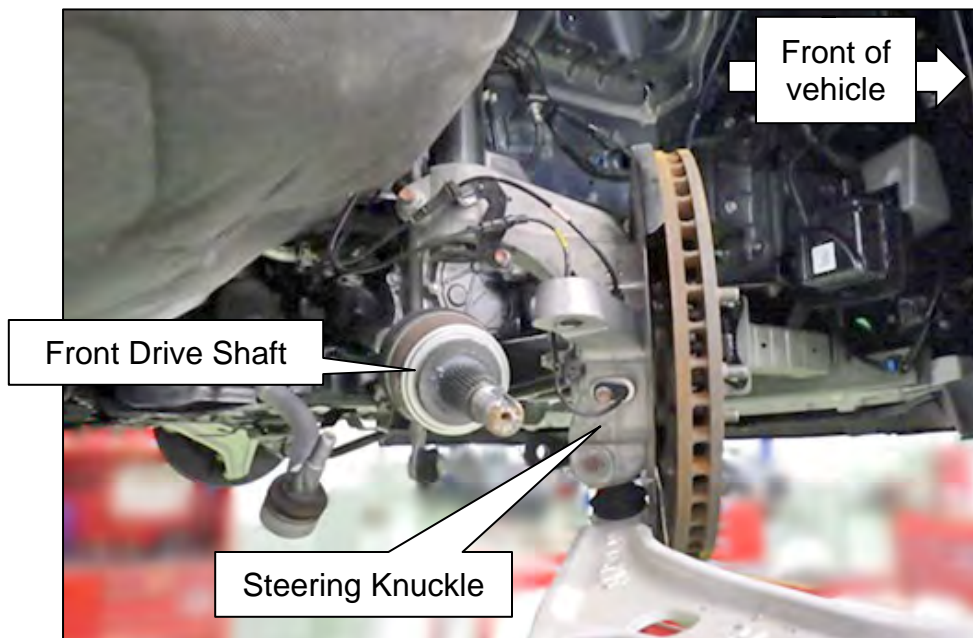

Figure 55

74. Repeat steps 67-73 on the driver (LH) side of the vehicle to separate the driver (LH) side Front Drive Shaft from the steering knuckle.
75. Raise the vehicle to a comfortable height to work under the vehicle.
76. Disconnect the passenger (RH) side coolant hose (water hose) from the lithium-ion battery and drain the coolant into an appropriate container.

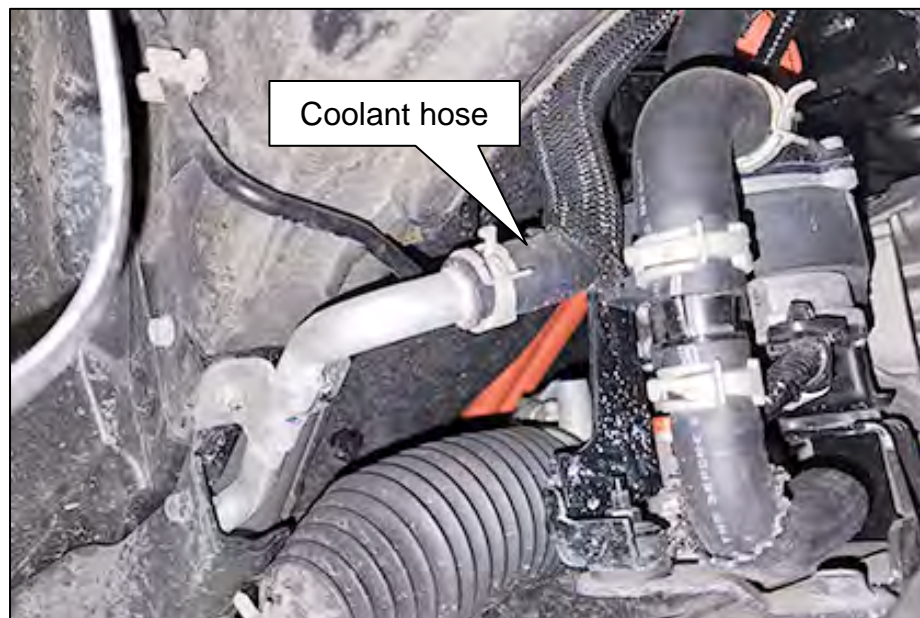

Figure 56



77. Disconnect the driver (LH) side coolant hose (water hoses) from the lithium-ion battery and drain the coolant into an appropriate container.



Figure 57

### Remove the Electric Water Pump from the Traction Motor

78. Disconnect both coolant hoses (Water Hose Lower) from the Electric Water Pump where shown in Figure 58 and Figure 59.

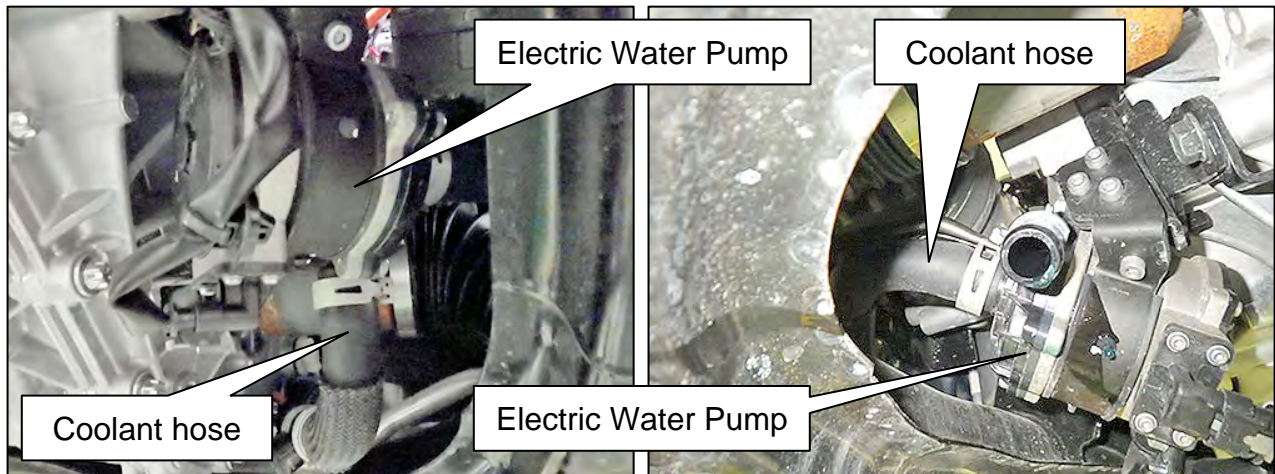

Figure 58

Figure 59



79. Disconnect the Electric Water Pump's wiring harness connector.

80. Detach two (2) wiring harness clips where shown in Figure 60.

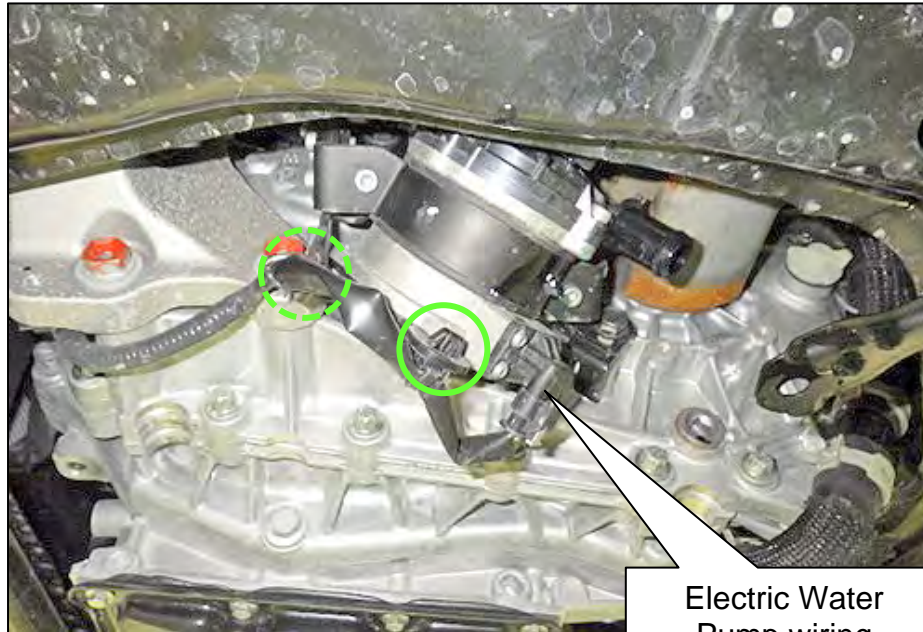

Figure 60

Electric Water Pump wiring harness connector

81. Remove the Electric Water Pump.

- Two (2) bolts.

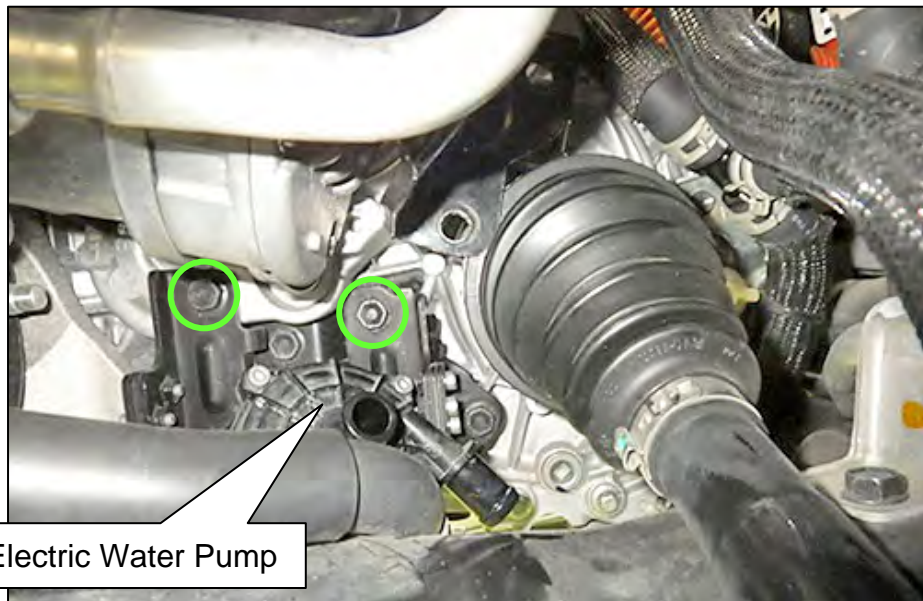

Figure 61

Electric Water Pump

## Remove the Front Suspension Member with Traction Motor from the Vehicle

82. Place a powertrain lift under the Front Suspension Member.
  - Place cushioning material at four (4) locations.

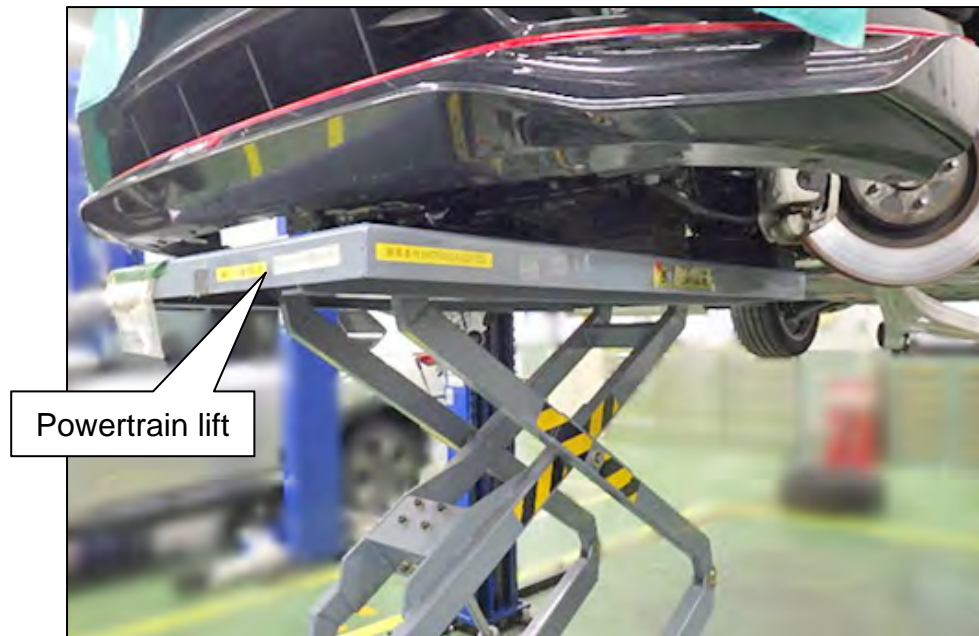

Figure 62

83. Remove the high voltage harness bracket mounting bolt.

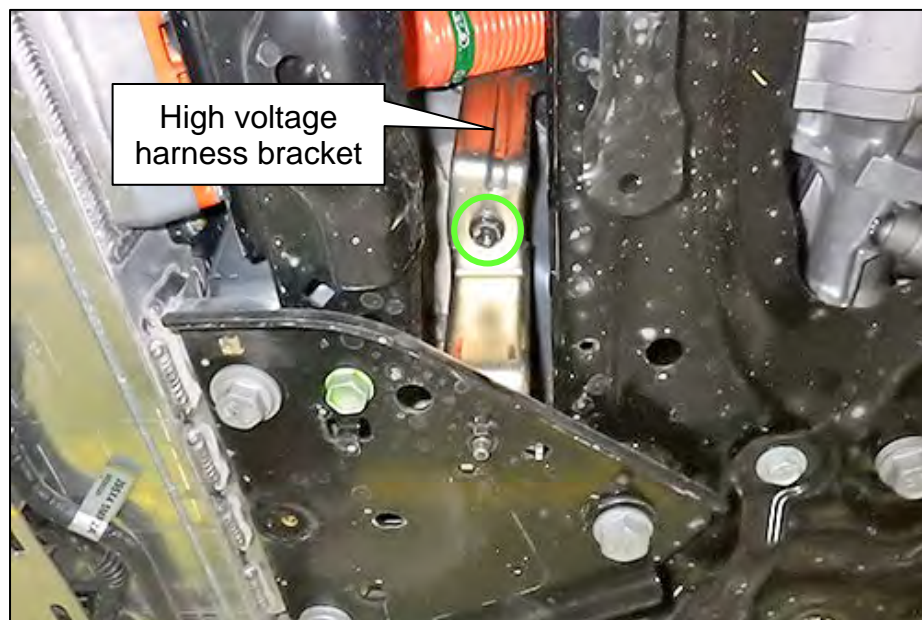

Figure 63



84. Remove the mounting bolts of both the Front Member Stay (right side) and the Front Member Stay (left side), and then remove them from the vehicle.

- Six (6) bolts.

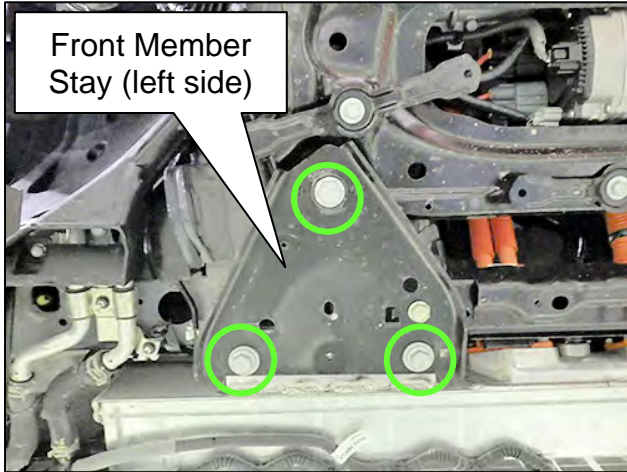

Figure 64

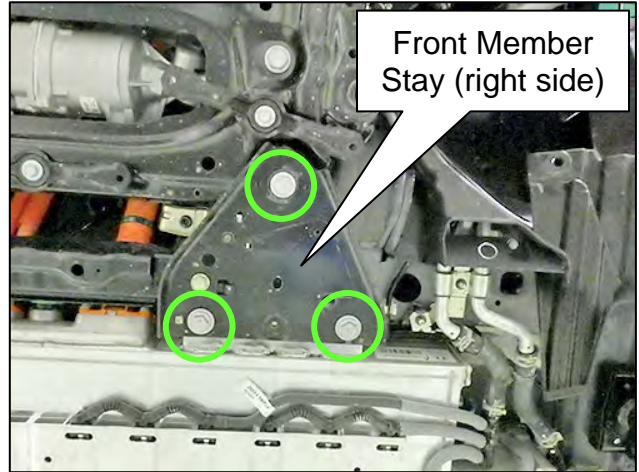

Figure 65

85. Remove both of the Front Suspension Member mounting bolts.

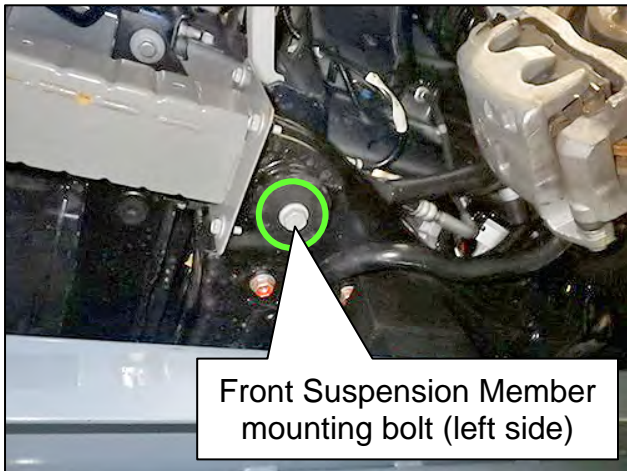

Figure 66

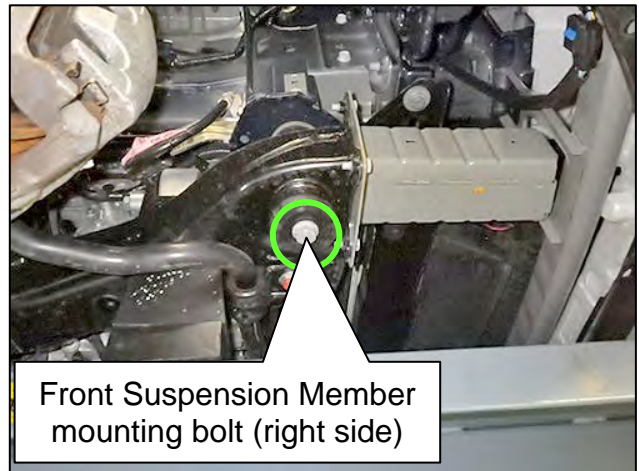

Figure 67

86. Lower the Front Suspension Member with Traction Motor away from the vehicle.



Figure 68

87. Secure the Front Suspension Member to the powertrain lift.

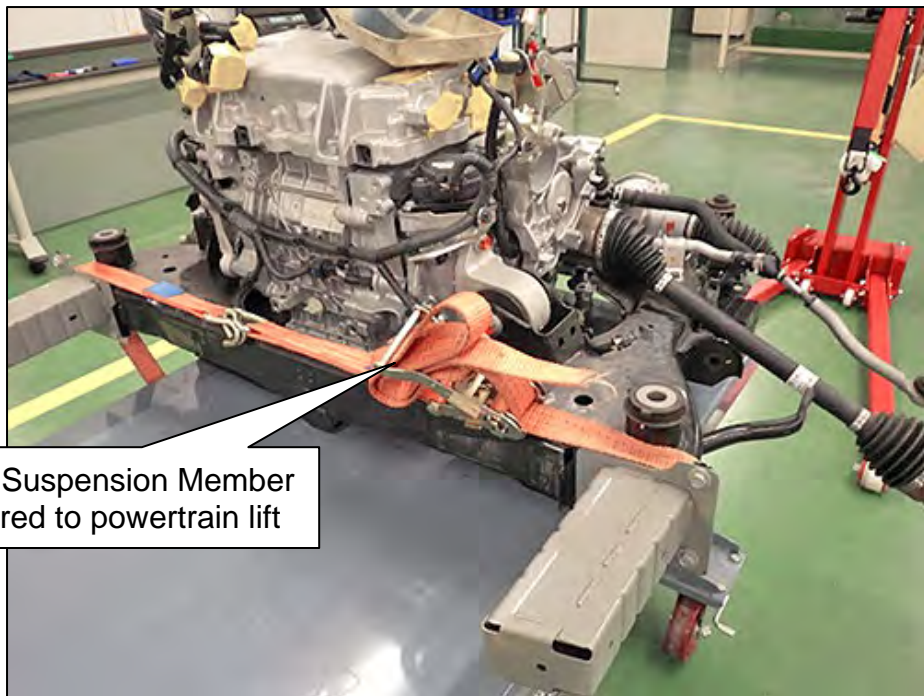

Front Suspension Member  
secured to powertrain lift

Figure 69



## Disconnect the Coolant Hoses (water hoses)

88. Remove the coolant Reservoir Tank's cap and drain the coolant into an appropriate container.

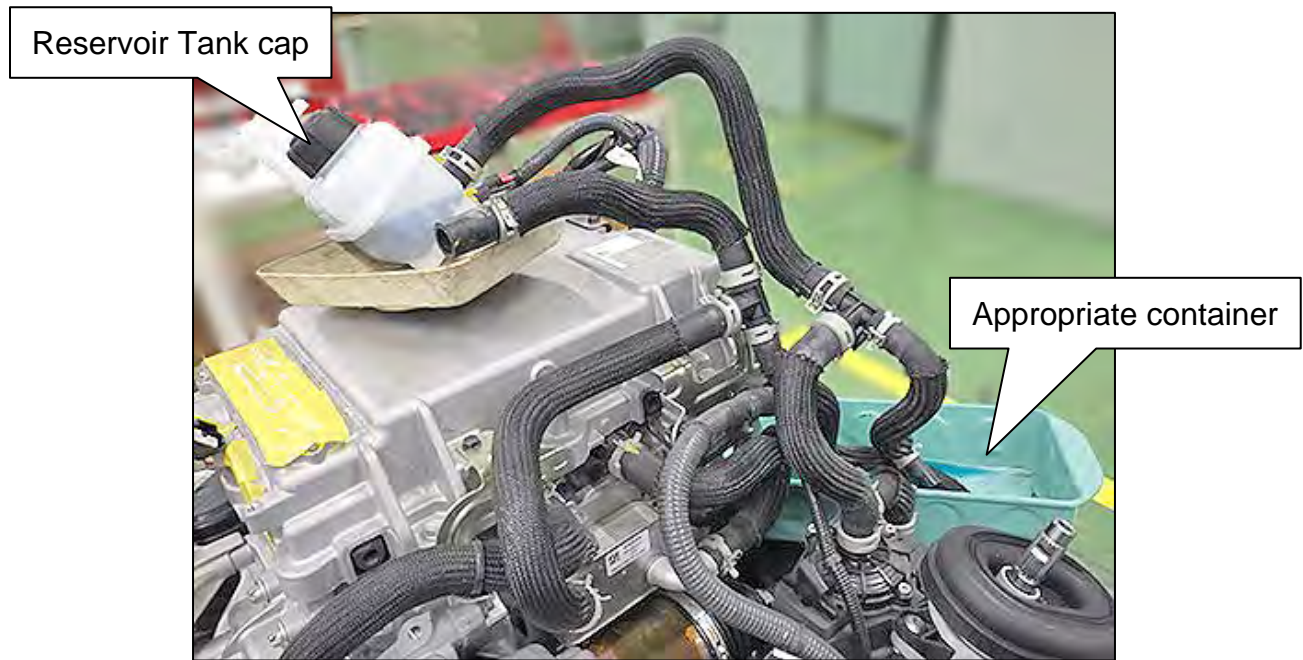

Figure 70

89. Detach the Traction Motor Inlet Hose (traction motor side) from its bracket at the 3-way connector where shown in Figure 71.
90. Disconnect the Traction Motor Inlet Hose (traction motor side) from the left side of the Water Cooler where shown in Figure 71.

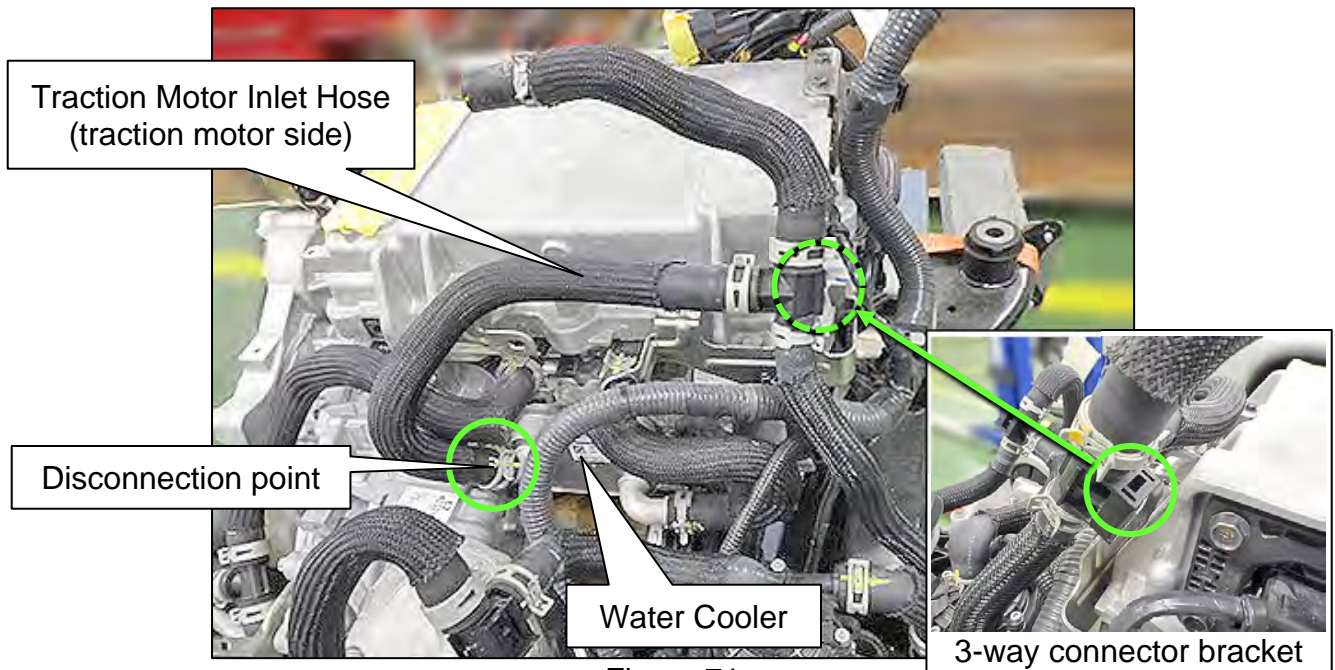

Figure 71

91. Unbolt the two (2) hose bracket bolts shown in Figure 72.
92. Disconnect the Radiator Hose Lower (between the Traction Motor Inverter and Electric Water Pump 3) directly above the hose that was disconnected in step 90.

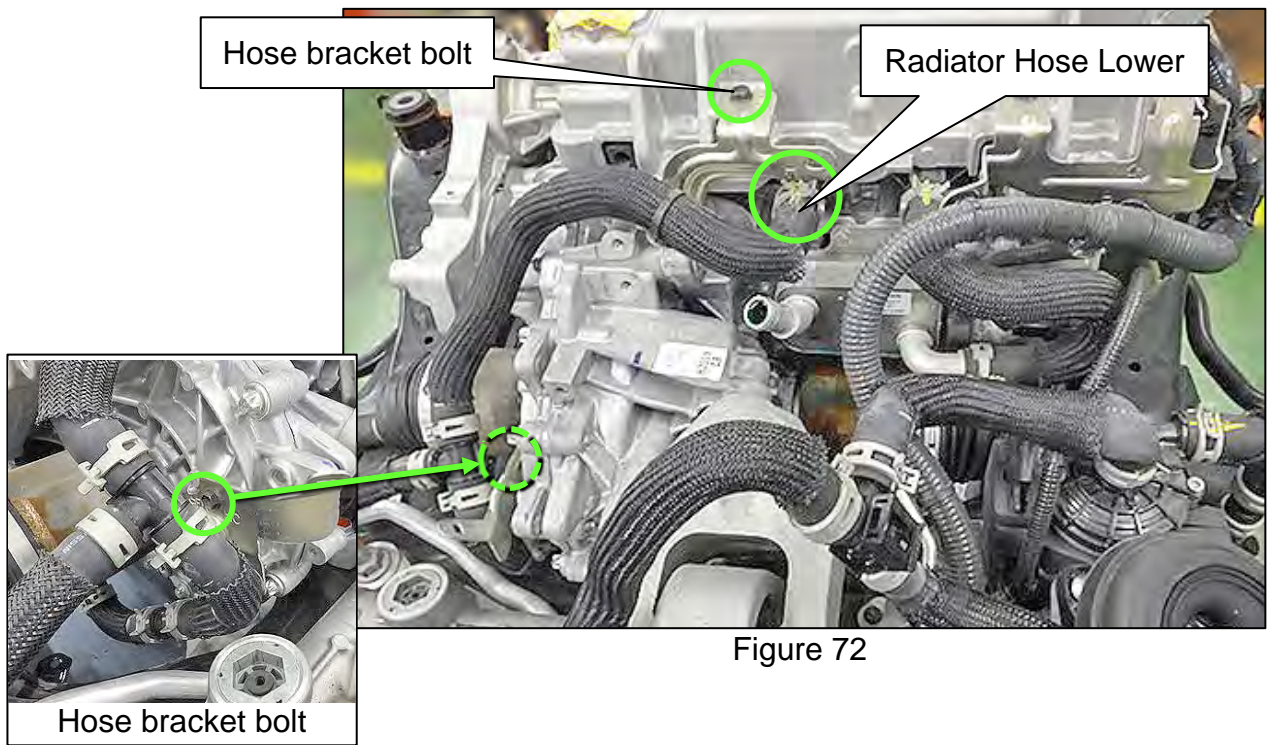

Figure 72

93. Completely remove the Traction Motor Inlet Hose, shown in Figure 73, completely.

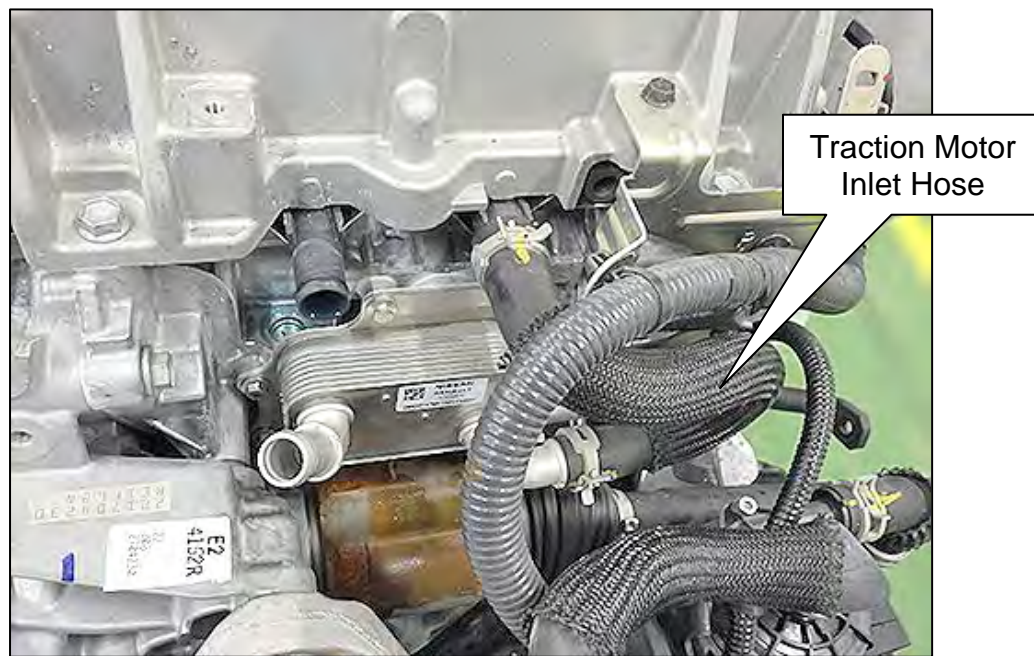

Figure 73



94. Disconnect the Electric Water Pump's wiring harness connector, and then detach the wiring harness clip from its bracket.

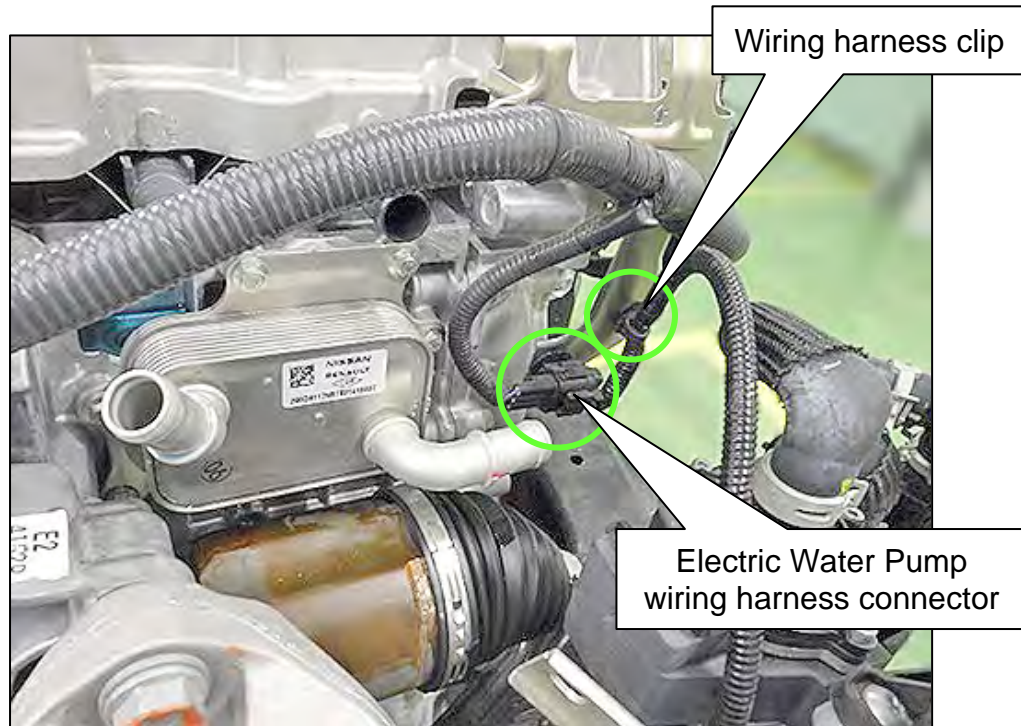

Figure 74

95. Remove the four (4) wiring harness plugs of the Electric Power Steering where shown in Figure 75.
96. Detach the two (2) Electric Power Steering wiring harness clips (1 hidden in Figure 75).

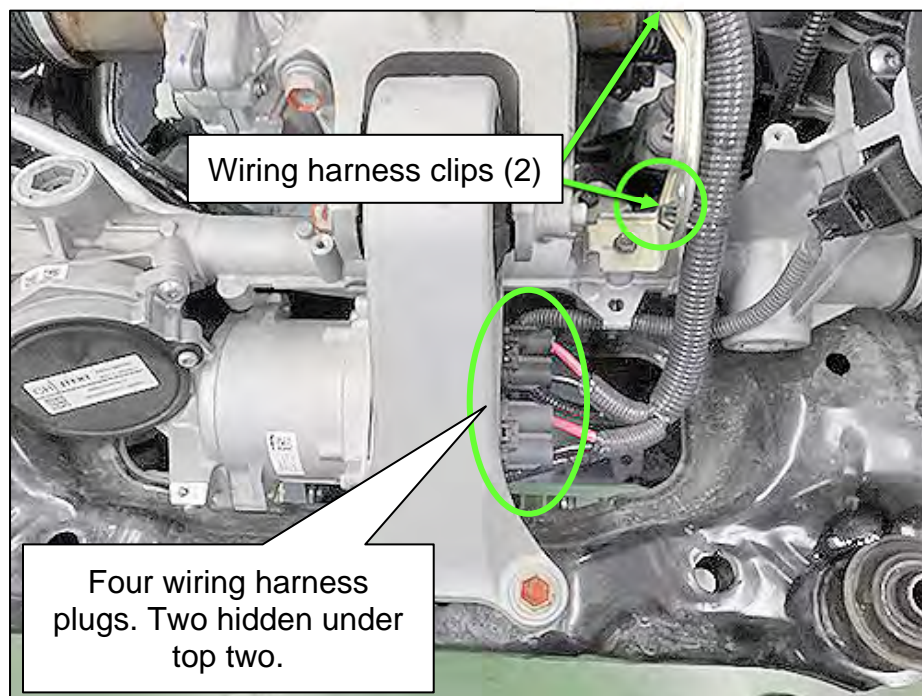

Figure 75

## REMOVAL OF THE TRACTION MOTOR, INVERTER, AND REDUCTION GEAR FROM THE FRONT SUSPENSION MEMBER

97. Install engine EV traction motor slinger brackets (part number NI-53355) at three (3) points on the Traction Motor (Figure 76).
98. Attach two (2) lifting belts (part number NI-50309) to the EV traction motor slinger brackets and connect to a hoist.

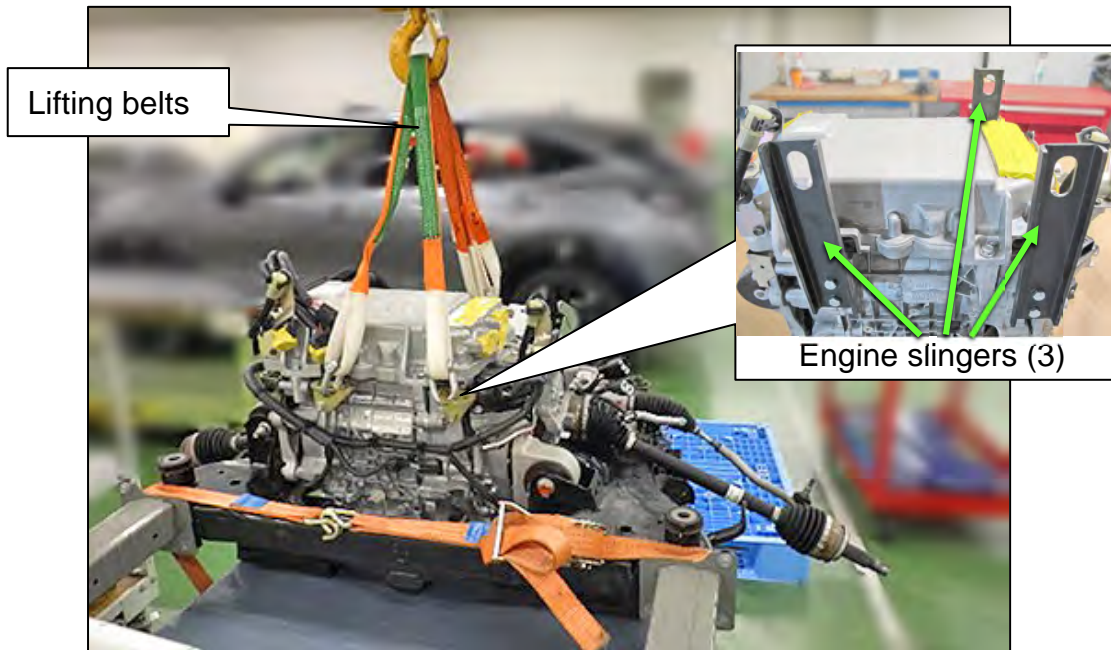

Figure 76

99. Remove the nuts and bolts from the motor mounts (3 locations shown in Figure 77, below, and Figure 78 and Figure 79 on page 42).

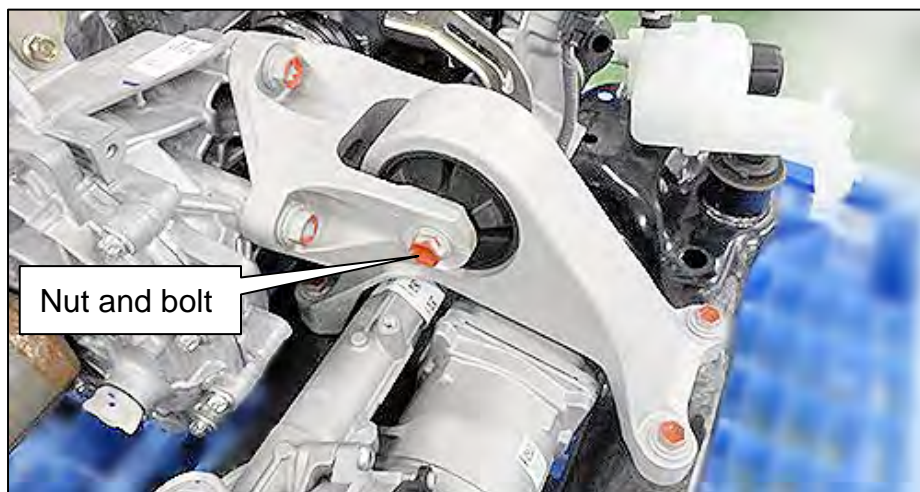

Figure 77





Figure 78

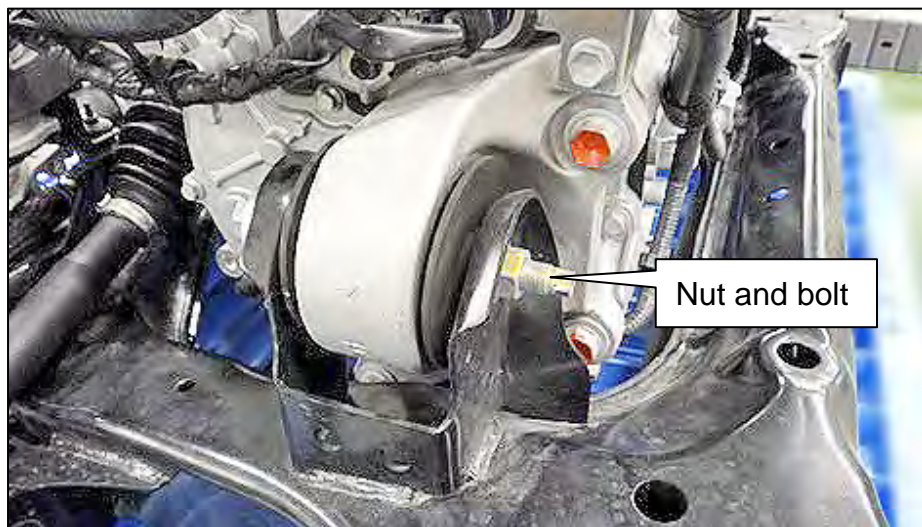

Figure 79

100. Lift the Traction Motor, Inverter, and Reduction Gear assembly with a hoist, and then move them to a workbench.

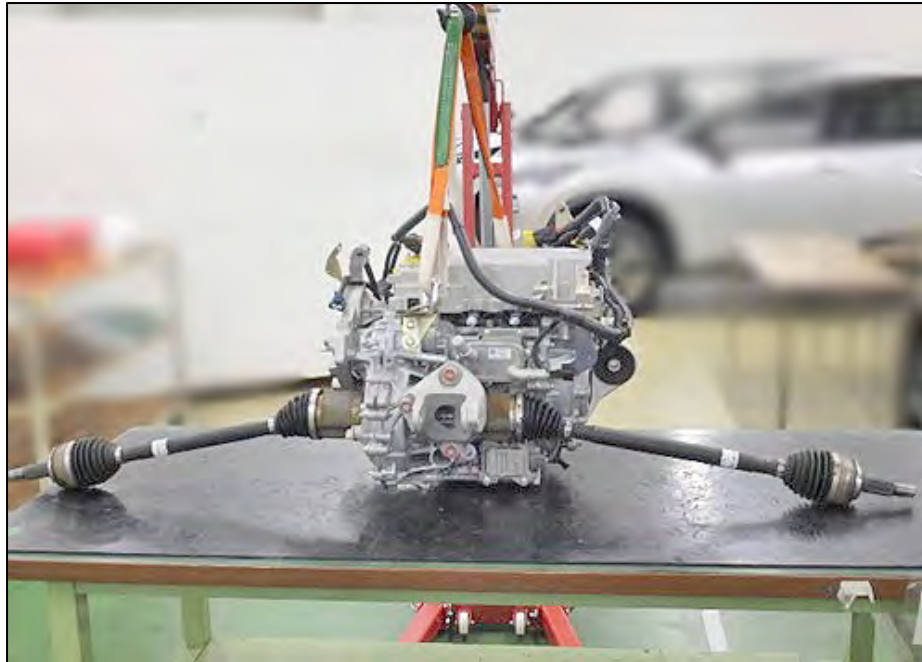

Figure 80

101. Place the Traction Motor, Inverter, and Reduction Gear assembly horizontally on the work bench with cushioning material to stabilize it.

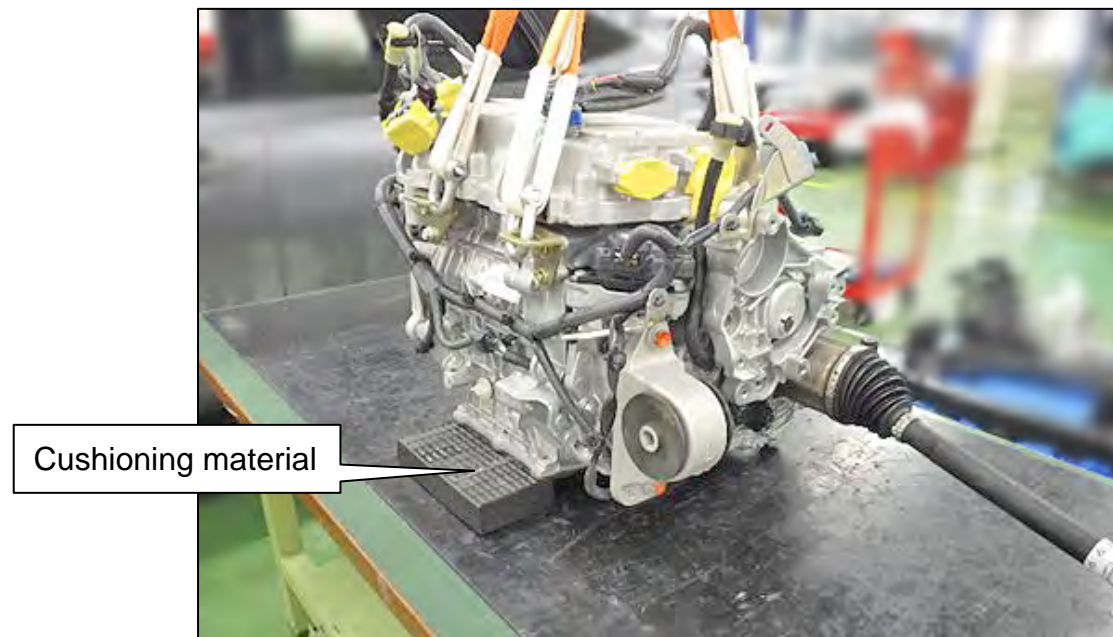

Figure 81

102. Remove the engine slingers (three locations) and move the hoist out of the way.



103. Disconnect the Parking Actuator wiring harness connector and three (3) associated wiring harness clips (Figure 82).

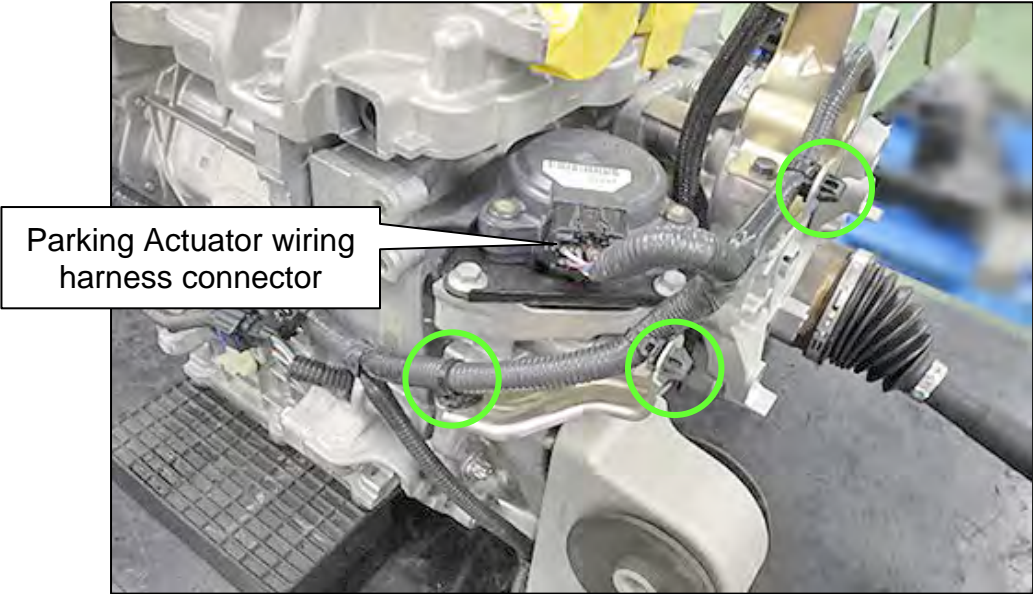

Figure 82

104. Disconnect the front wiring harness connector shown in Figure 83.

105. Unlock the five (5) harness clamps shown in Figure 83 to release the front wiring harness.

**HINT:** The wiring harness clamps must be unlocked for reuse.

**NOTICE**

If the wiring harness clamps are removed from their anchor points without releasing the locks first, the mounting part of the harness clamps will be damaged.

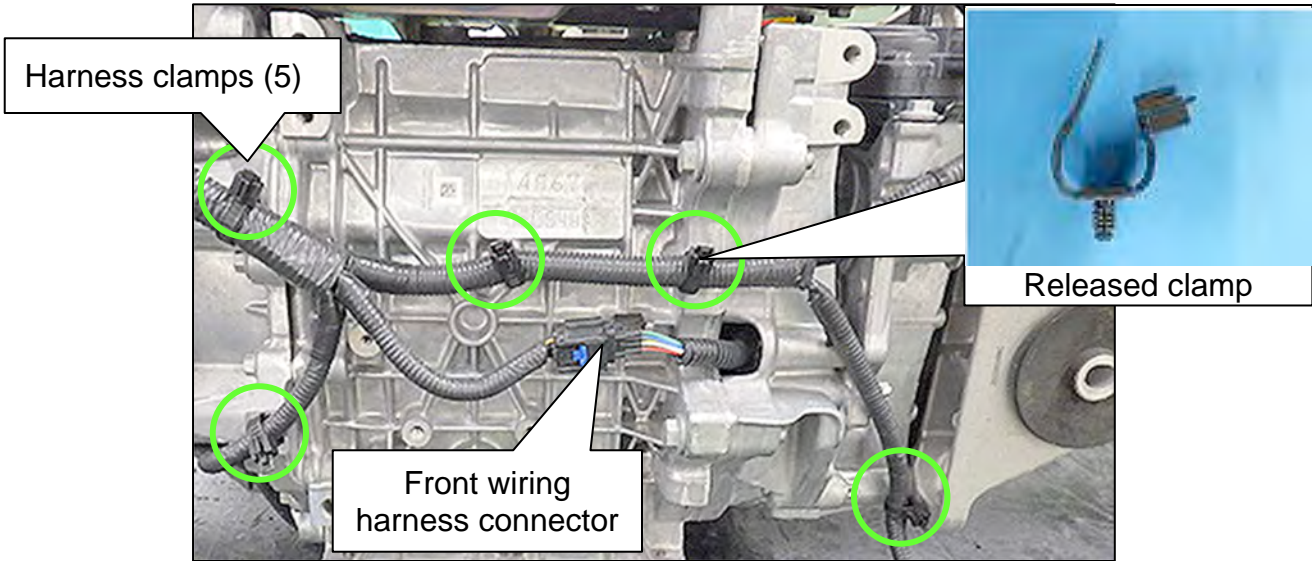

Figure 83

106. Disconnect the four (4) wiring harness connectors shown in Figure 84.

- Located on the passenger (RH) side wiring harness.

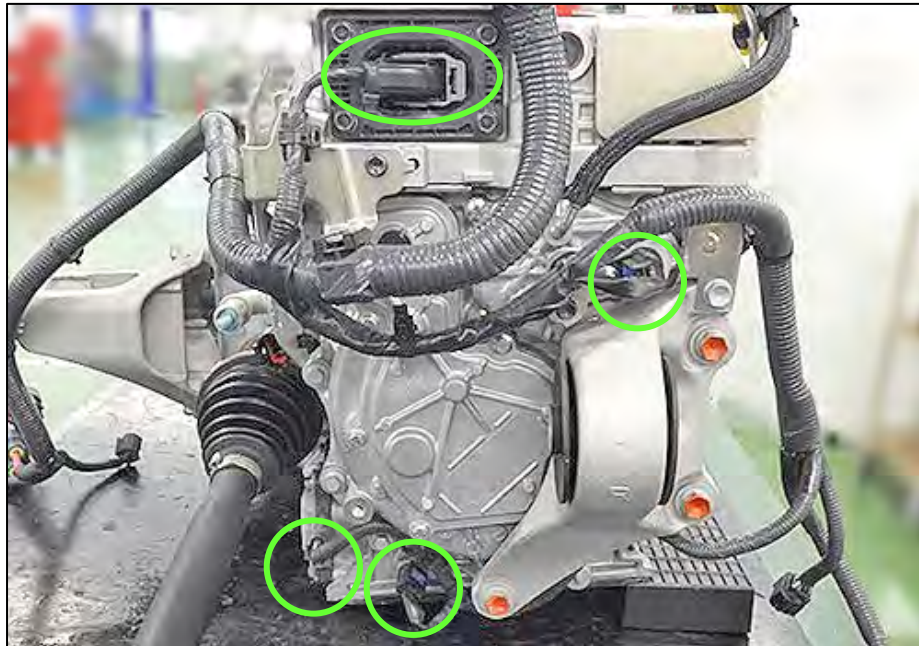

Figure 84

107. Unlock the four (4) wiring harness clamps on the passenger (RH) side wiring harness (Figure 85). Two (2) wiring harness clamps are hidden behind motor mount.

**HINT:** The wiring harness clamps must be unlocked for reuse.

**NOTICE**

If the wiring harness clamps are removed from their anchor points without releasing the locks first, the mounting part of the harness clamps will be damaged.

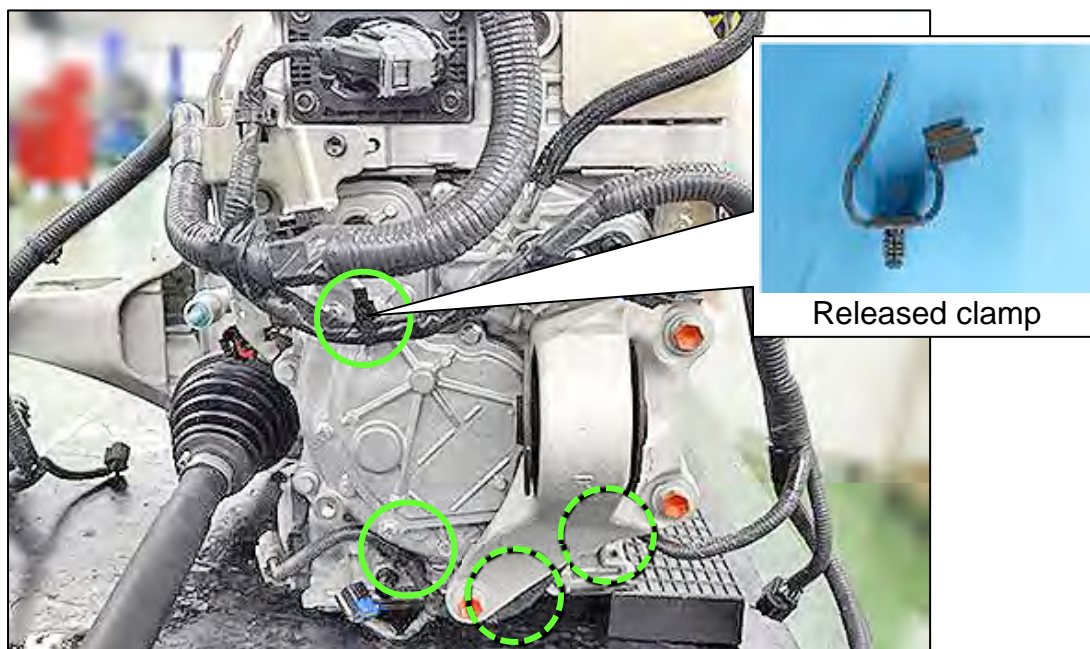

Figure 85



108. Remove the two (2) wiring harness brackets shown in Figure 86.

- Two (2) bolts for each bracket (one hidden in Figure 86).

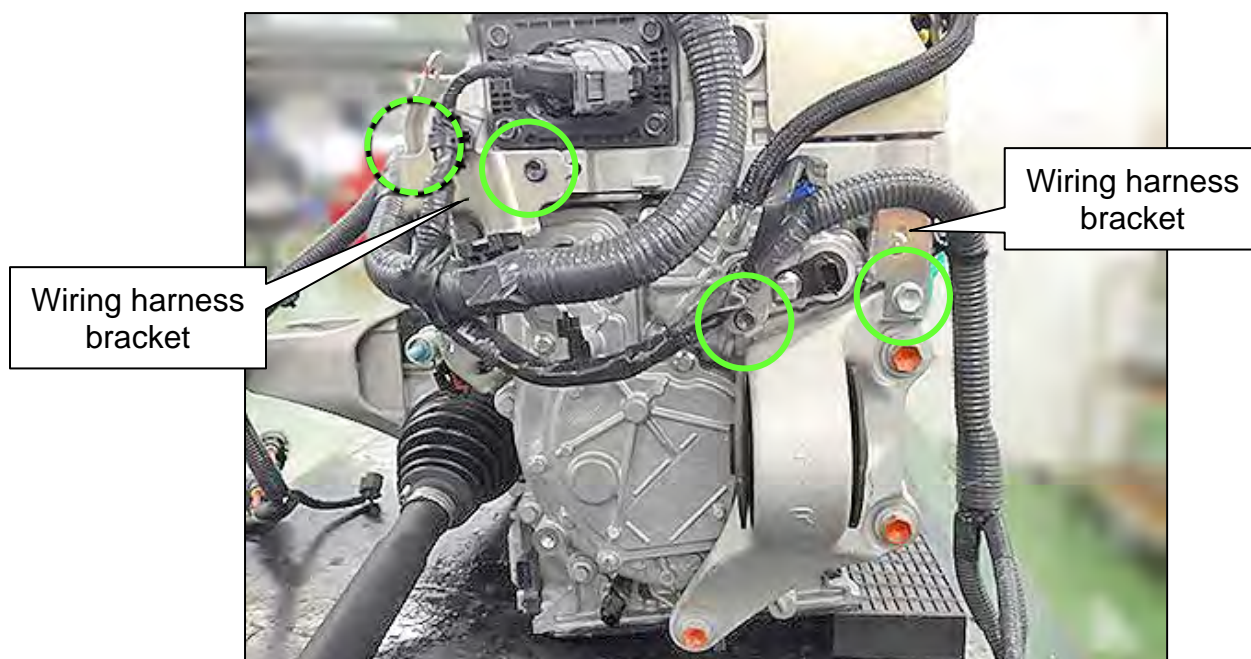

Figure 86

109. Remove the associated harness shown in Figure 86.

110. Remove the nine (9) unlocked wiring harness clamps shown in Figure 87, and Figure 88 on page 47.

**HINT:**

- Do not remove with a clip driver.
- Turn counterclockwise to remove them.

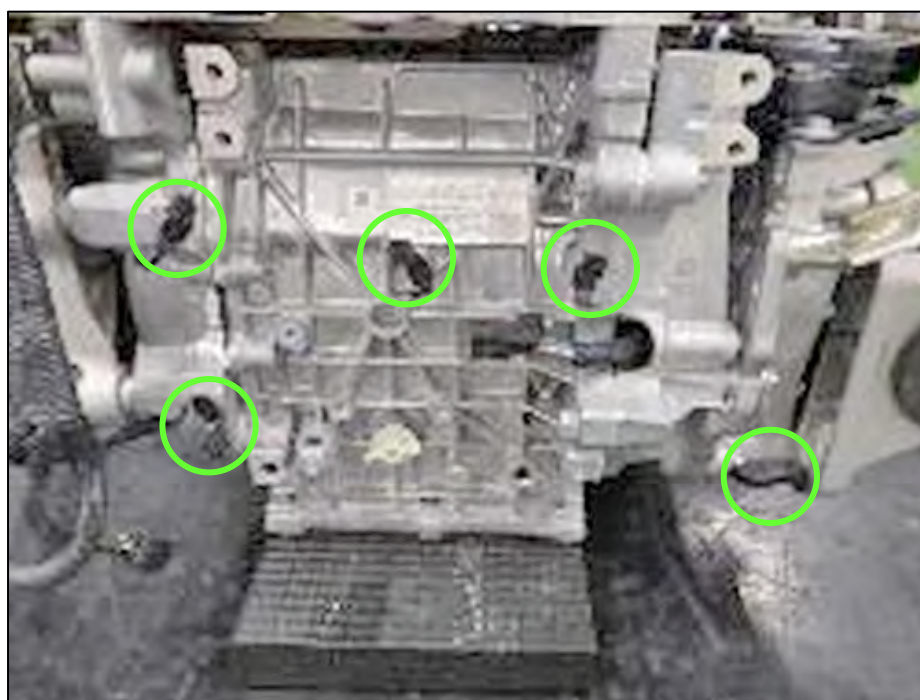

Figure 87

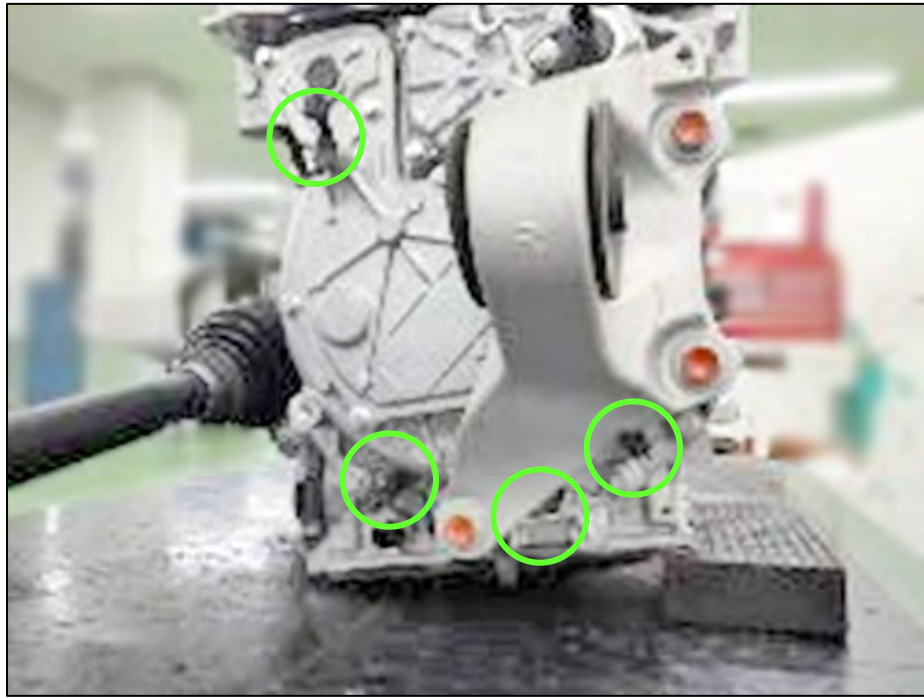

Figure 88

### Remove the Motor Mounts

111. Remove the passenger (RH) side Motor Mount.

- Three (3) bolts.

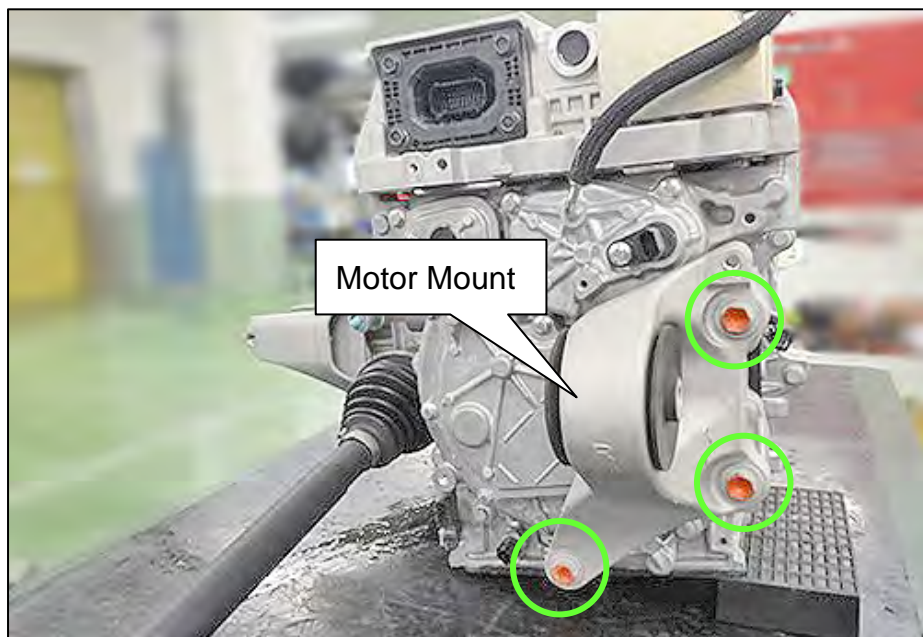

Figure 89



112. Remove the Motor Mounting Bracket Rear.

- Three (3) bolts.

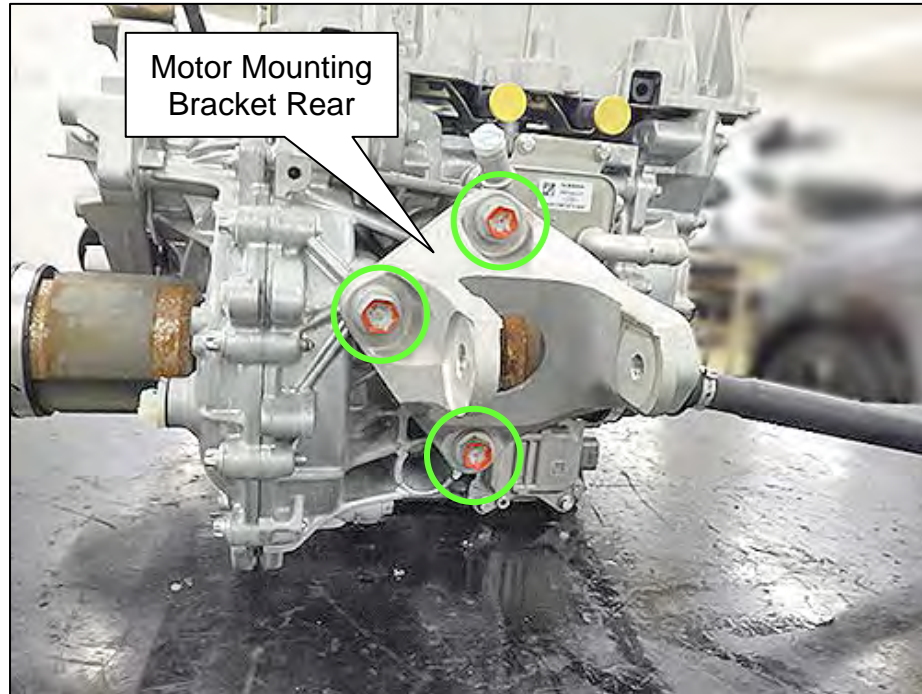

Figure 90

113. Remove the Air Breather Hose from its clamp.

114. Remove the Electric Compressor Bracket.

- Four (4) bolts.

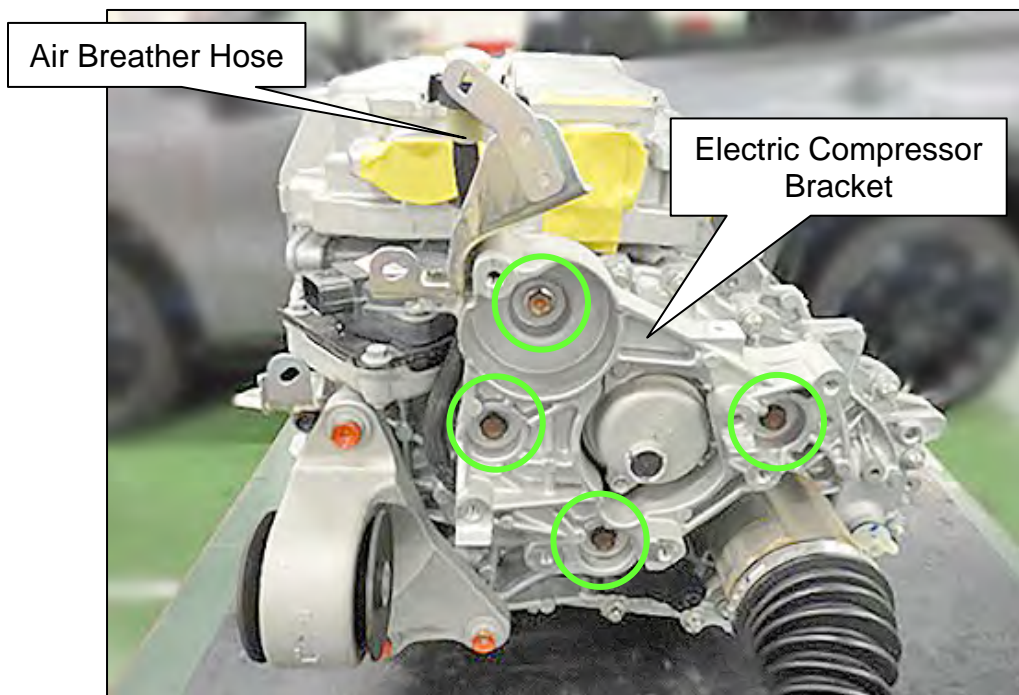

Figure 91

## Remove the Reduction Gear

115. Remove the eight (8) mounting bolts that retain the Reduction Gear to the Traction Motor.

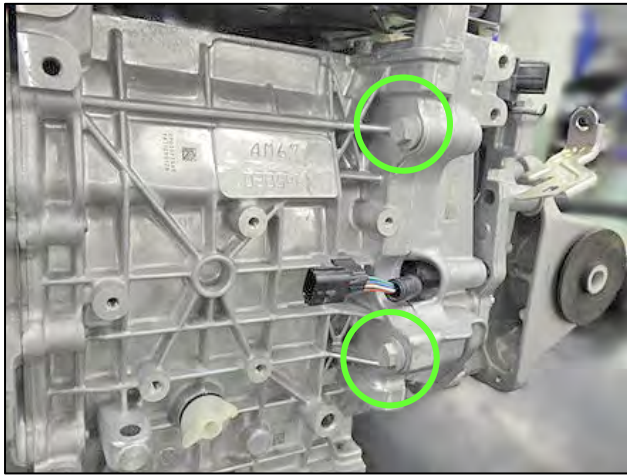

Figure 92

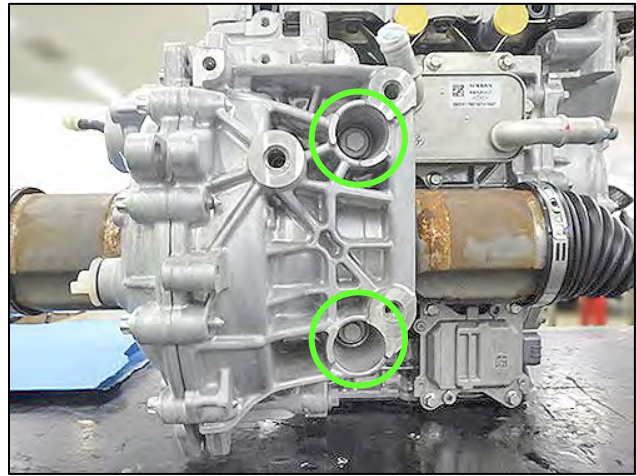

Figure 93

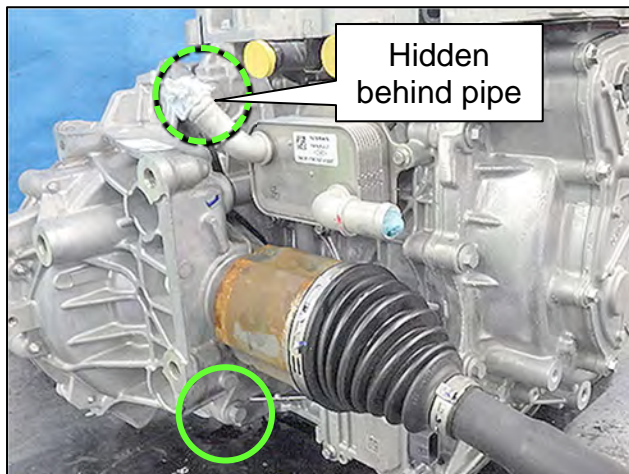

Figure 94

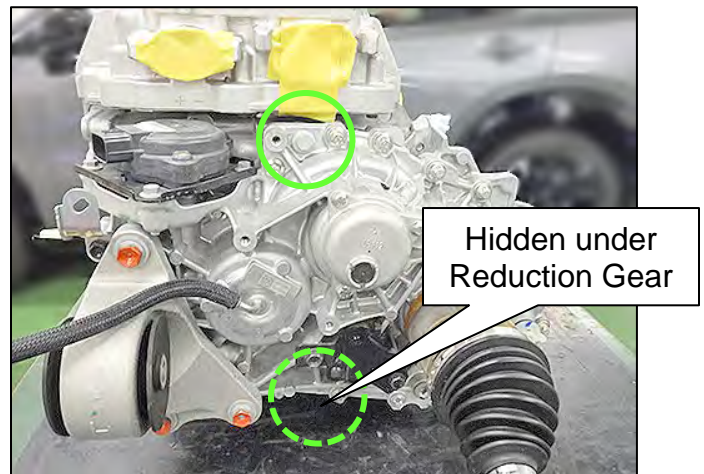

Figure 95

116. Separate the Reduction Gear away from the Traction Motor.

**IMPORTANT:** Ensure that the two (2) dowel pins remain with the Traction Motor (Figure 96).

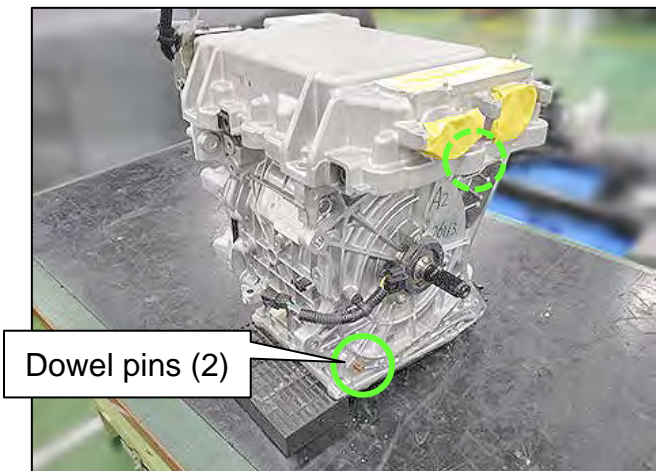

Figure 96



## Remove the Inverter

117. Detach the air breather hose from its bracket.

- Shown detached in Figure 97.

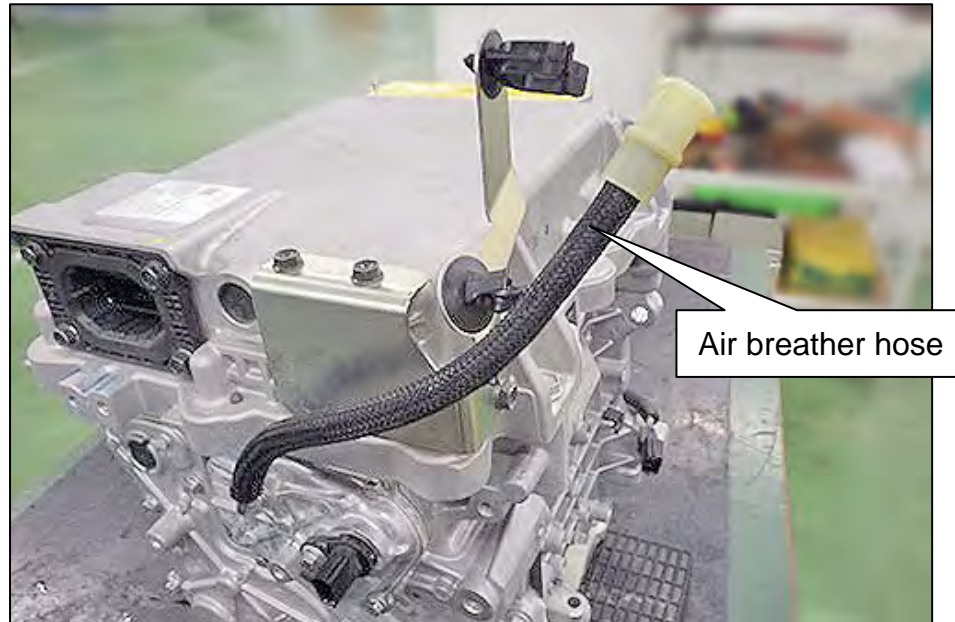

Figure 97

118. Remove Three-Phase Bus Bar Cover mounting bolts, and then remove Three-Phase Bus Bar Cover.

- Four (4) bolts.

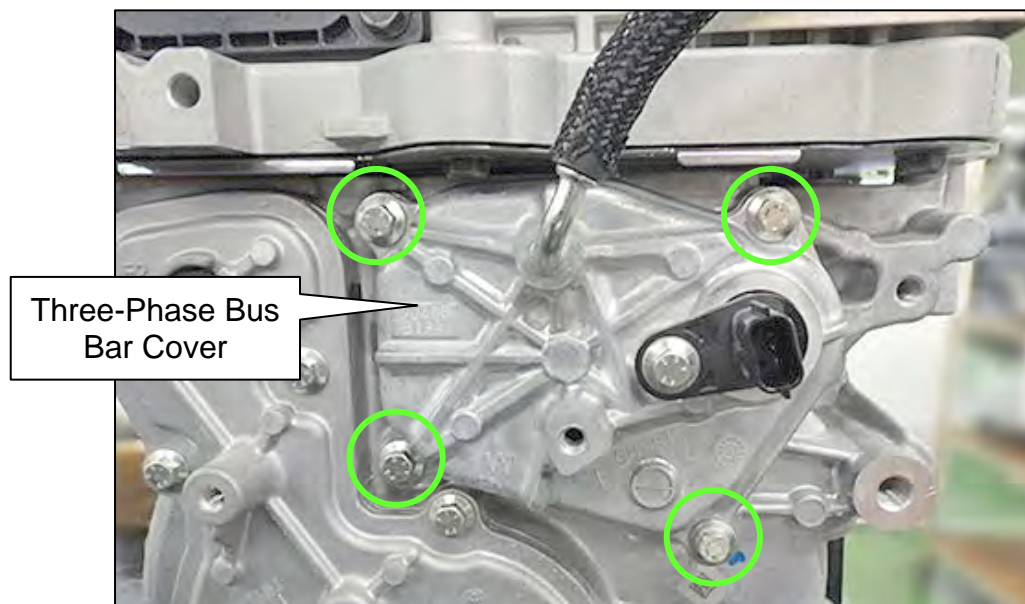

Figure 98

119. Disconnect the Front Traction Motor Stator Temperature Sensor wiring harness connector.

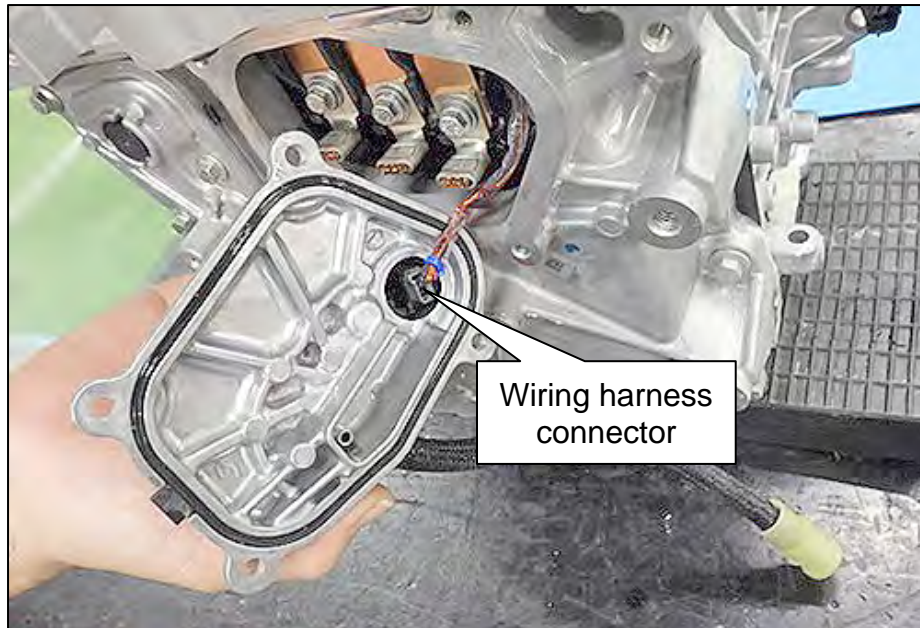

Figure 99

120. Remove Excitation Cover mounting bolts, and then remove Excitation Cover (Figure 100).

- Eight (8) bolts.

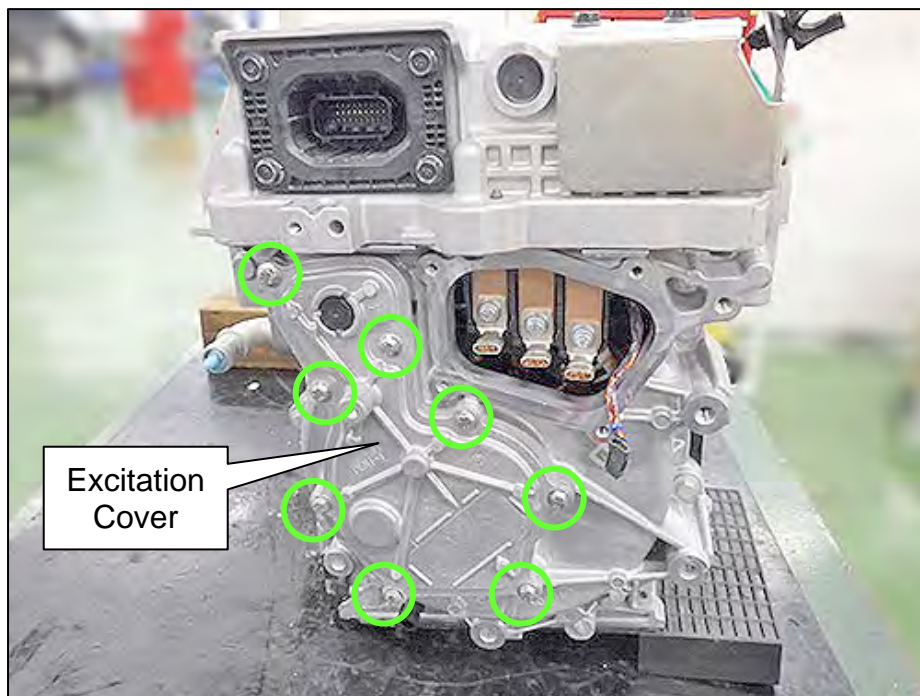

Figure 100



121. Remove Three-Phase Bus Bar Cover Terminal and the Excitation-Phase Bus Bar Terminal mounting bolts (Figure 101).

- Five (5) bolts.

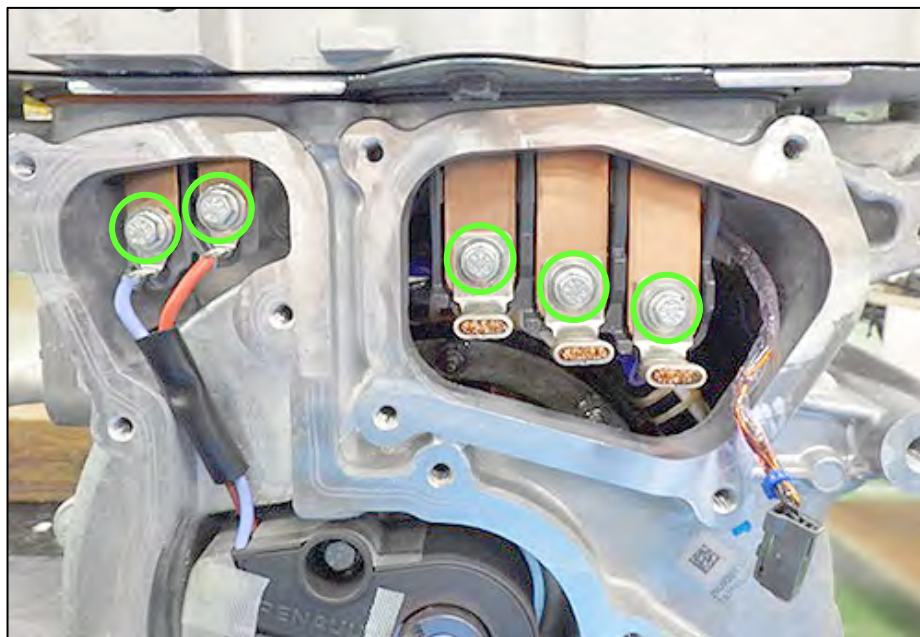

Figure 101

122. Remove the four (4) mounting bolts that retain the Inverter to the Traction Motor, and then remove the Inverter.

**NOTICE**

Ensure that the Inverter's bus bars are not damaged. Place the Inverter gently onto a cushioned surface until it is assembled onto the new Traction Motor.

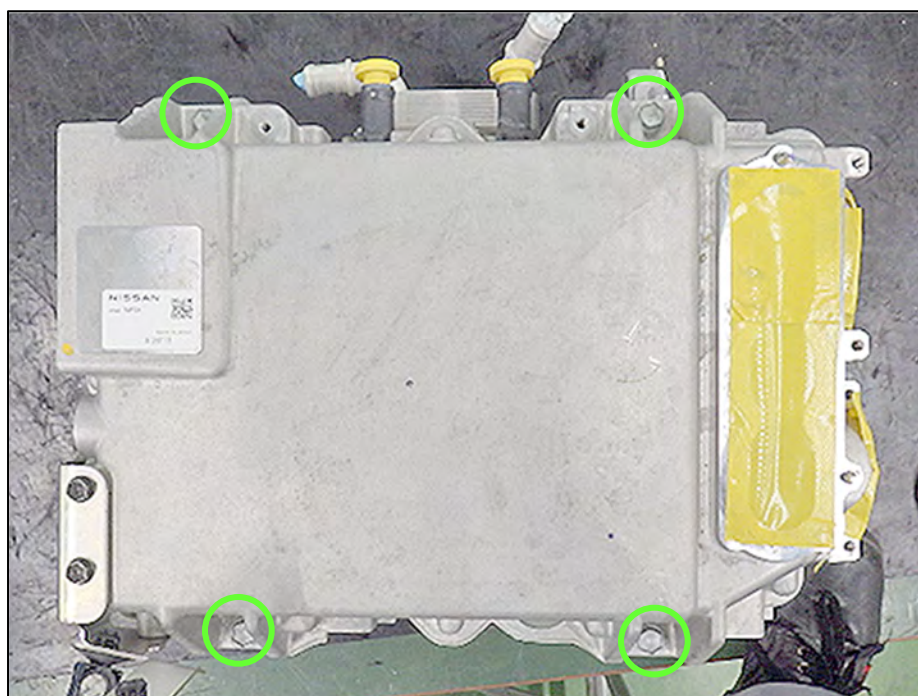

Figure 102

## Install the Inverter to the New Front Traction Motor

123. On the new Traction Motor, remove Three-Phase Bus Bar Cover mounting bolts, and then remove Three-Phase Bus Bar Cover.

- Four (4) bolts.
- Refer to Figure 98 on page 50.
- Refer to **PARTS INFORMATION** on page 110.

**IMPORTANT:** Be careful to not damage the Three-Phase Bus Bar Cover gasket during removal as it will be reused.

124. Disconnect the Front Traction Motor Stator Temperature Sensor wiring harness connector.

- Refer to Figure 99 on page 51.

125. Remove Excitation Cover mounting bolts, and then remove Excitation Cover.

- Eight (8) bolts.
- Refer to Figure 100 on page 51.

**IMPORTANT:** Be careful to not damage the Three-Phase Bus Bar Cover gasket during removal as it will be reused.

126. Install new gaskets into the Traction Motor.

- Refer to **PARTS INFORMATION** on page 110.

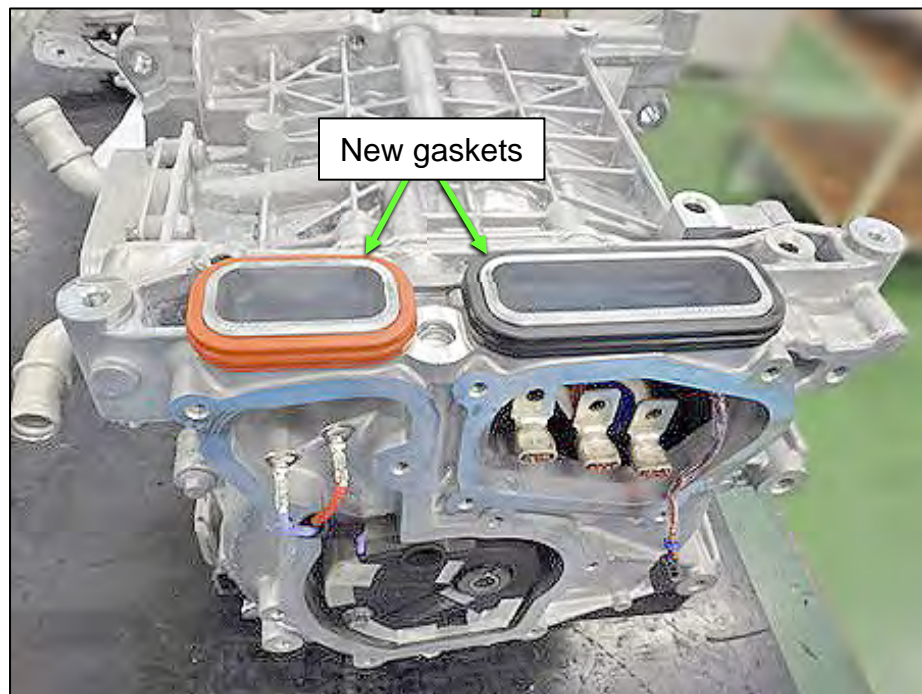

Figure 103



127. Install the Inverter to the new Traction Motor with four (4) bolts.

- Torque bolts to 25.0 N•m (2.6 kg-m, **18 ft-lb**).

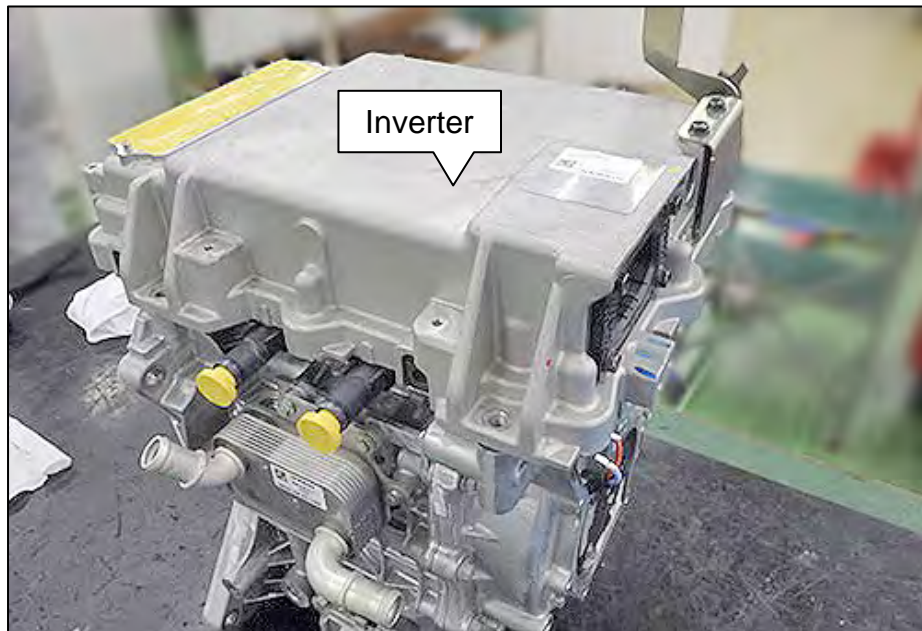

Figure 104

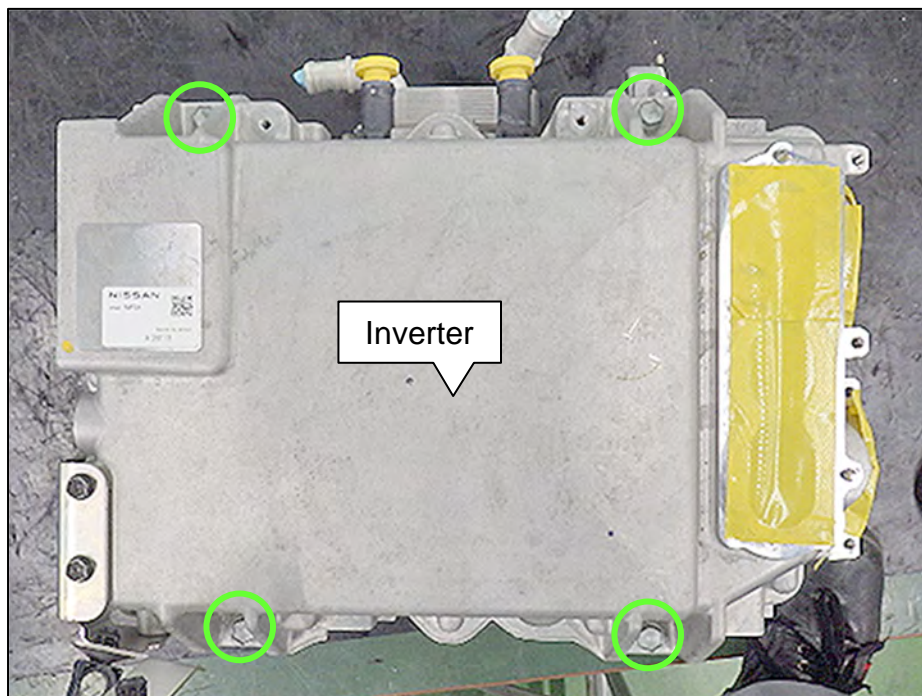

Figure 105

128. Connect all bus bar harness terminals in the orientation shown in Figure 106.

- Torque bolts to 8.0 N•m (0.8 kg-m, **71 in.-lb**).

**IMPORTANT:** The harness colors for the Excitation-Phase Bus Bar Terminals must be in correct locations.

- The left is blue and the right is red.

**CAUTION**

To prevent personal injury or vehicle damage, high voltage buss bar and terminal connection bolts must not be cross-threaded and must be torqued to the specified value.

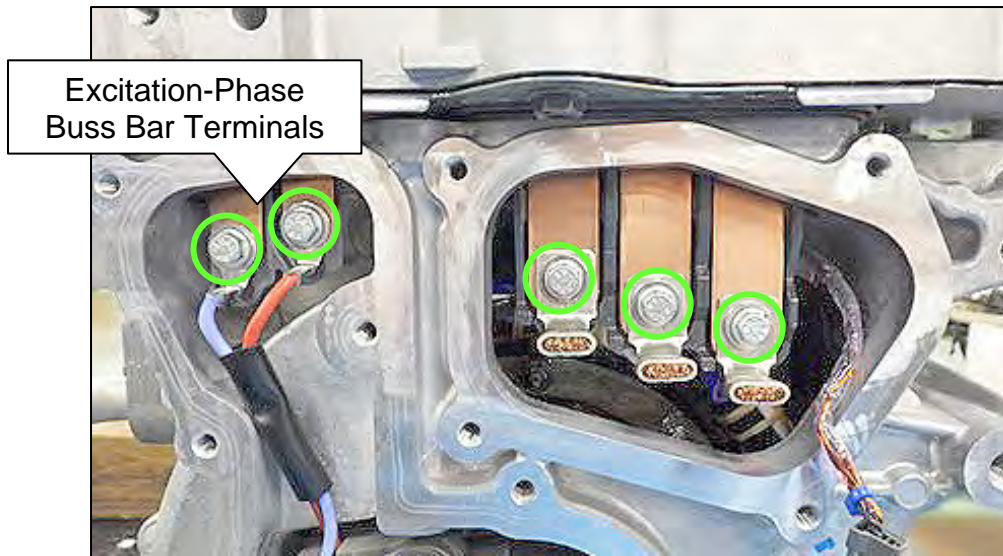

Figure 106

129. Install the Excitation Cover with gasket and bolts **finger tight**.

- Ensure that the gasket has not detached or twisted before installing it.
- Install the eight (8) bolts.

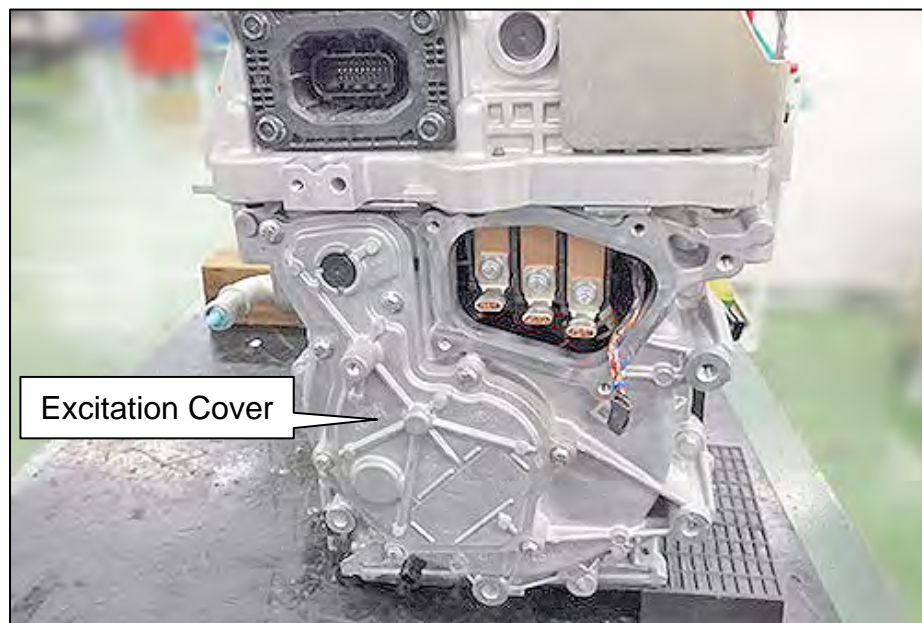

Figure 107



130. Tighten the Excitation Cover bolts in the sequence shown (1-8) in Figure 108.

- Torque bolts to 10.0 N•m (1.0 kg-m, **89 in.-lbs**).

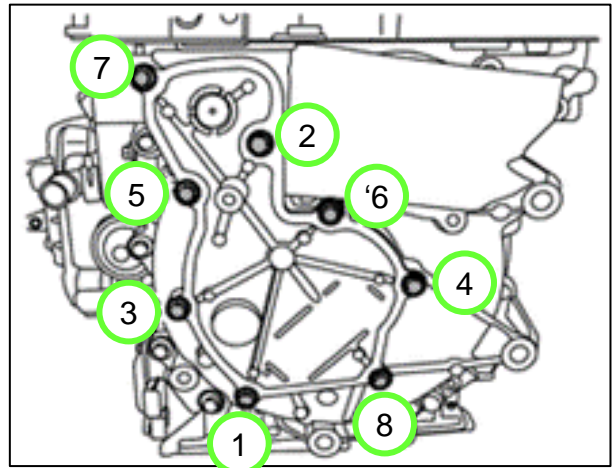

Figure 108

131. Connect the Front Traction Motor Stator Temperature Sensor wiring harness connector.

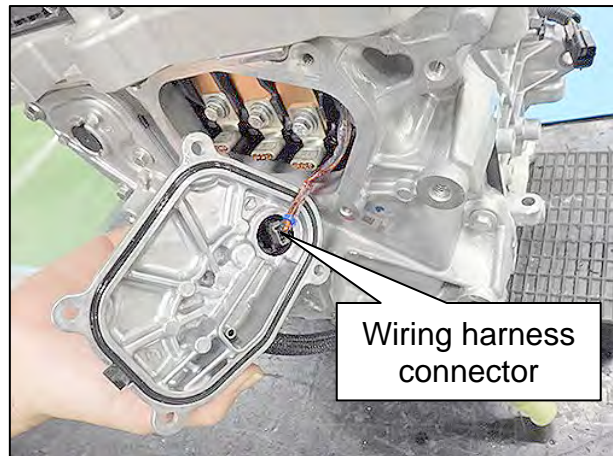

Figure 109

132. Install the Three-Phase Bus Bar Cover with gasket.

- Ensure that the gasket has not detached or twisted before installing it.
- Install the four (4) bolts **finger tight**.

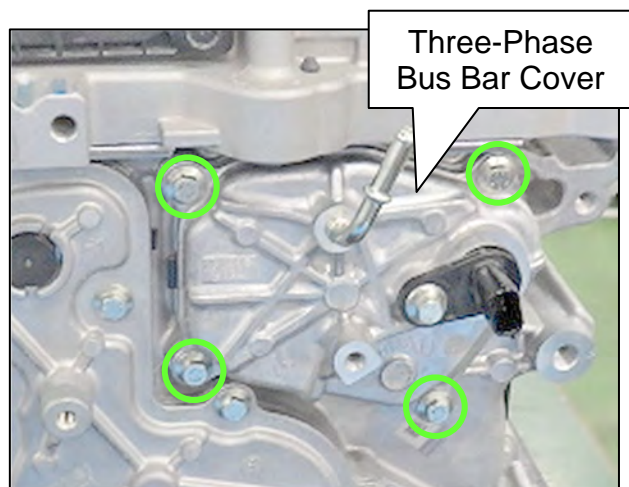

Figure 110

133. Tighten the Three-Phase Bus Bar Cover bolts in the sequence shown (1-4) in Figure 111.

- Torque bolts to 10.0 N•m (1.0 kg-m, **89 in.-lbs**).

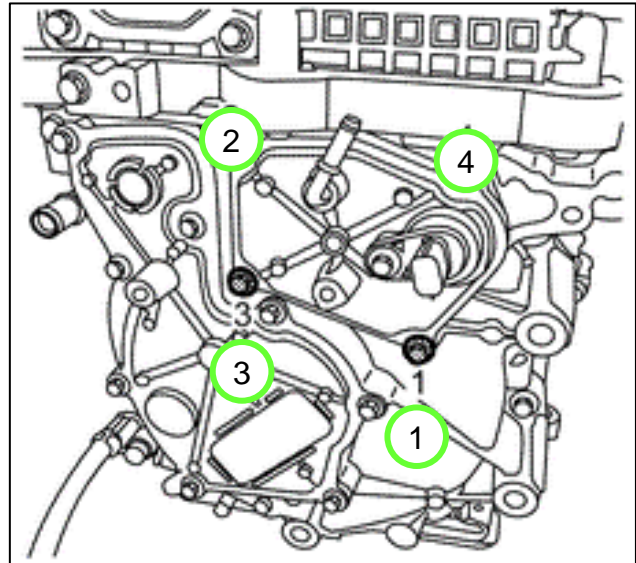

Figure 111

134. Install a new Air Breather Hose to the Three-Phase Bus Bar Cover and bracket.

- Refer to **PARTS INFORMATION** on page 110.

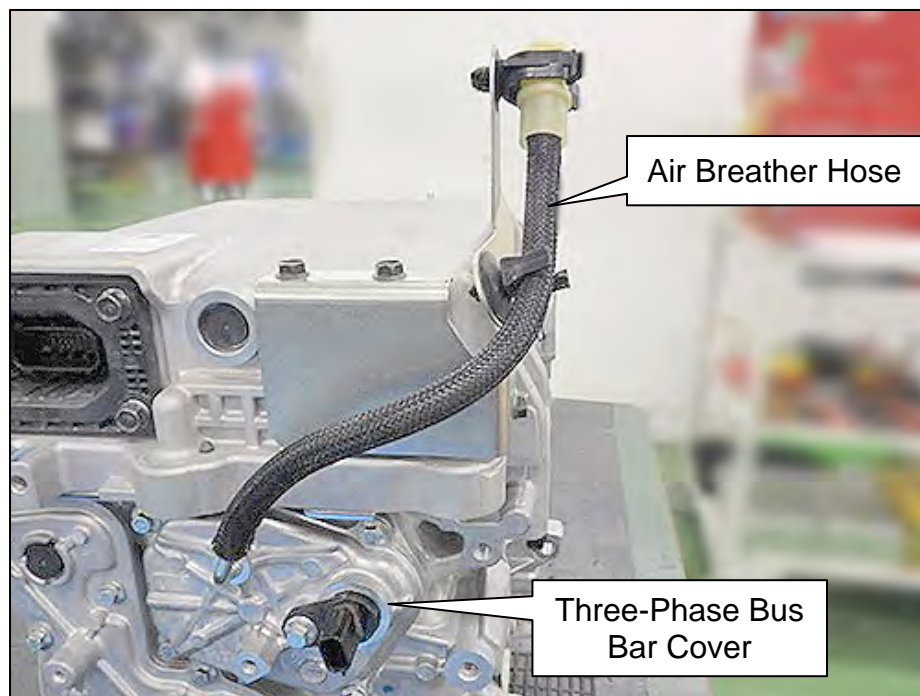

Figure 112



## Install the Reduction Gear

135. Apply a lithium-based grease that includes molybdenum disulfide to the O-ring inside lip of the Reduction Gear input seal.

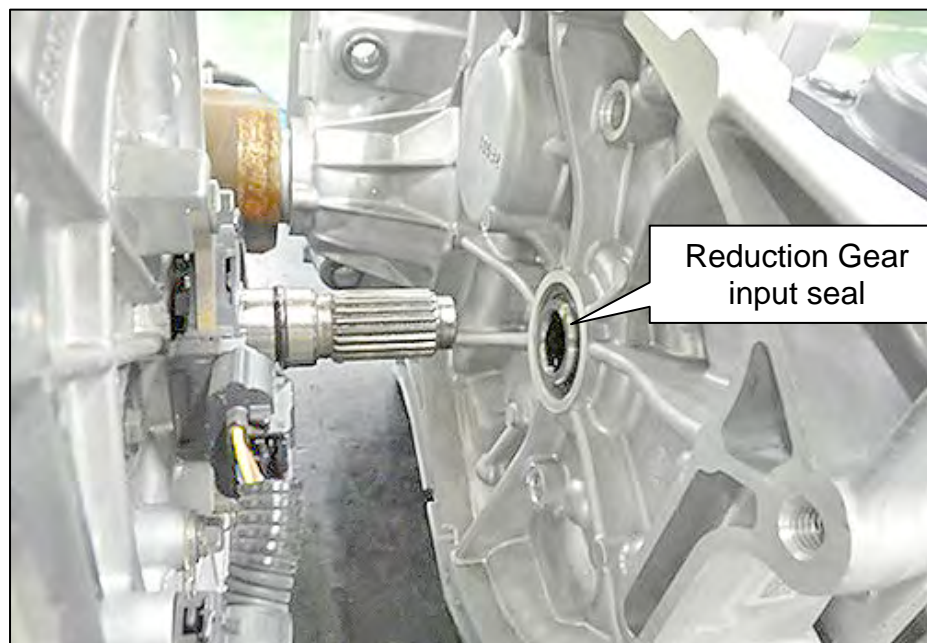

Figure 113

136. Install the Reduction Gear to the Traction Motor. Refer to Figure 92 – Figure 95 on page 49 for bolt locations.

- Eight (8) bolts.
- Torque bolts to 44.0 N•m (4.5 kg-m, **32 ft-lb**).

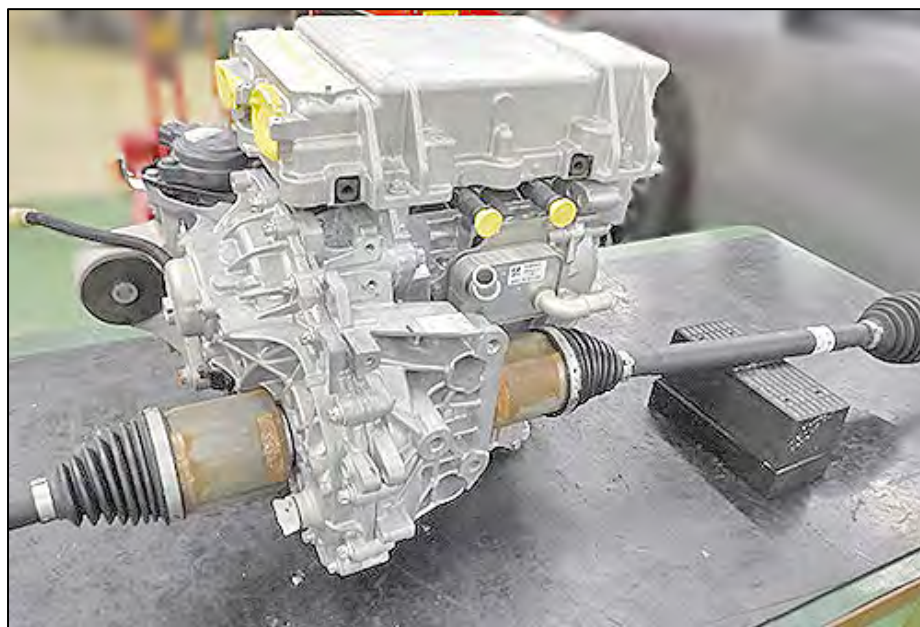

Figure 114

137. Install the Electric Compressor Bracket to the Reduction Gear.

- Four (4) bolts.
- Torque bolts to 25.0 N•m (2.6 kg-m, **18 ft-lb**).

138. Connect the Air Breather Hose into its bracket.

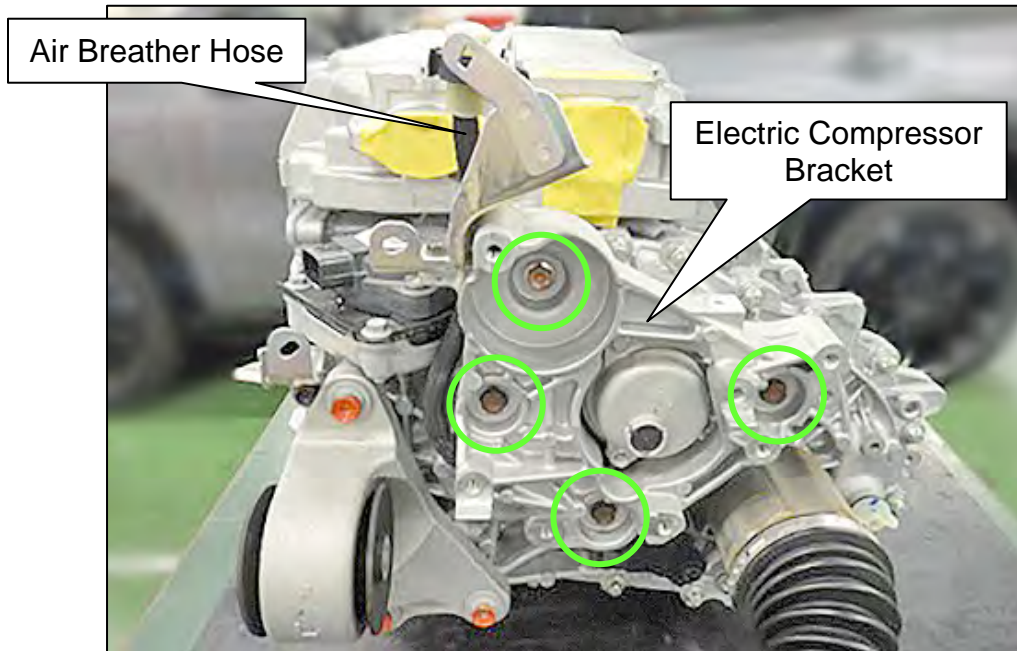

Figure 115

139. Install the Rear Motor Mount Bracket bolts **finger tight**.

- Three (3) bolts.

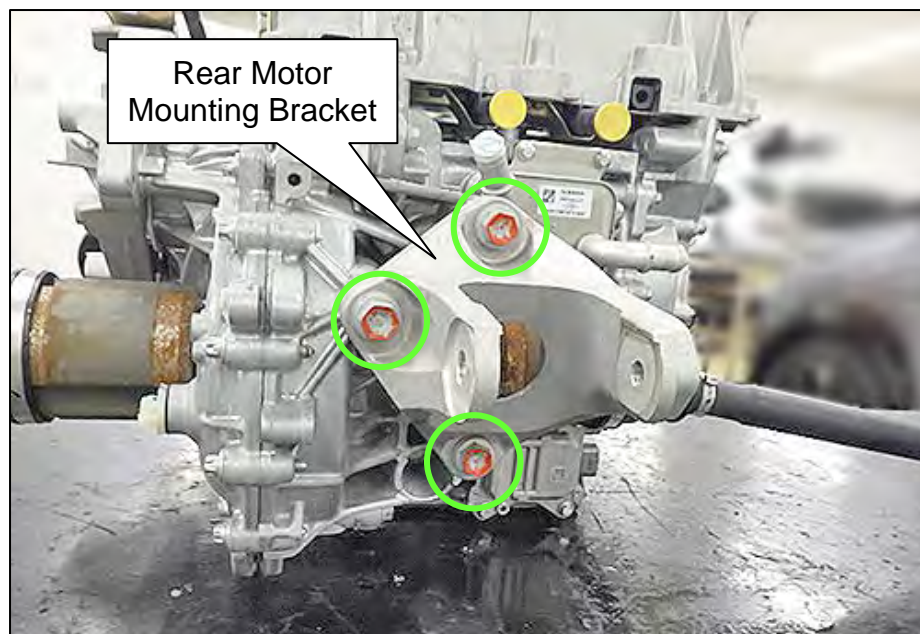

Figure 116



140. Torque the Rear Motor Mount Bracket bolts in the following order: **2 > 3 > 1**, refer to Figure 117.

- Torque bolts to 105.0 N•m (11.0 kg-m, **77 ft-lb**).

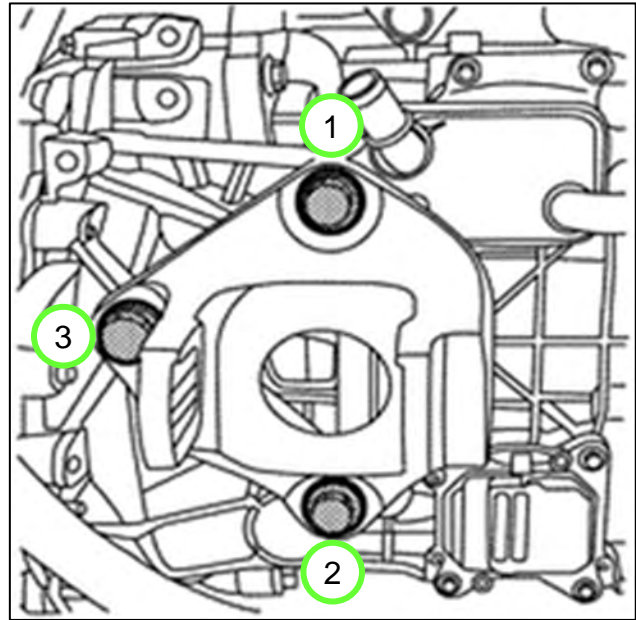

Figure 117

141. Install the passenger (RH) side Motor Mount bolts **finger tight**.

- Three (3) bolts.

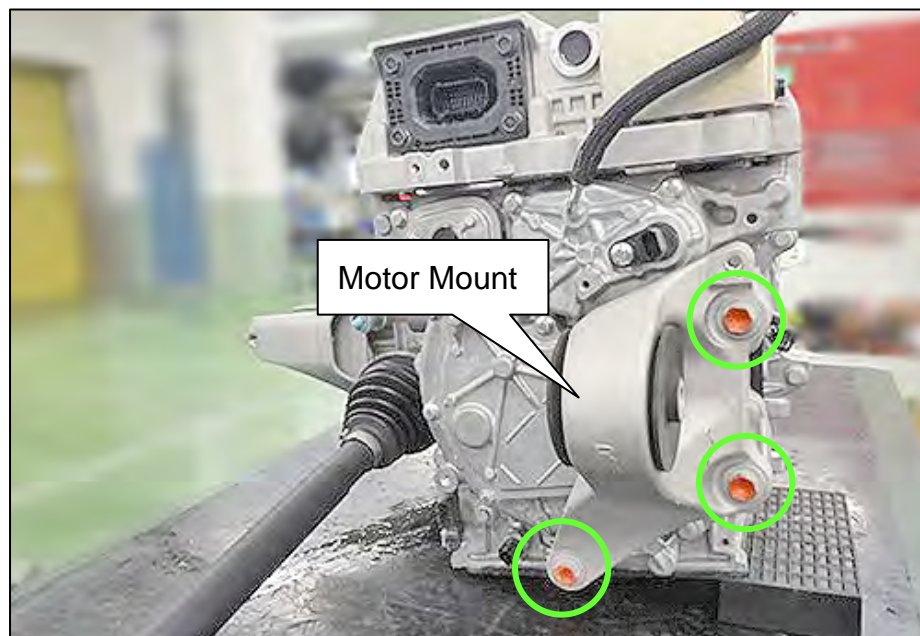

Figure 118

142. Torque the passenger (RH) side Motor Mount bolts in the following order: **2 > 3 > 1**, refer to Figure 119.

- Torque bolts to 62.0 N•m (6.3 kg-m, **46 ft-lb**).

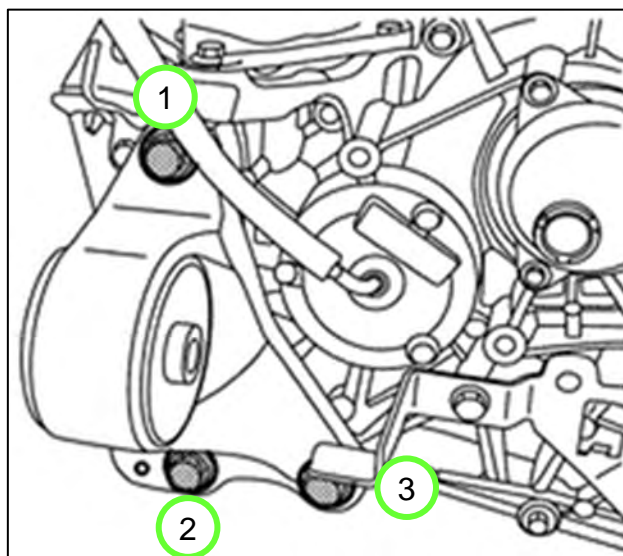

Figure 119



## Install the Wiring Harness

143. Install the nine (9) wiring harness clamps where shown in Figure 120 and Figure 121.

- Rotate the harness clamps clockwise to engage.

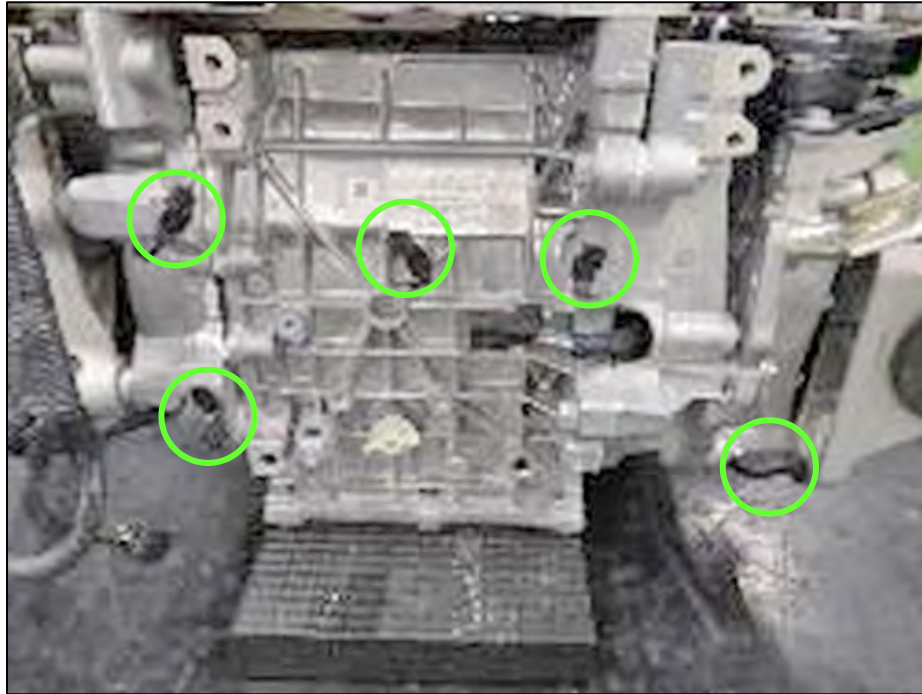

Figure 120



Figure 121

144. Attach the two (2) passenger (RH) side wiring harness brackets.
- Two (2) bolts for each bracket (one hidden in Figure 122).

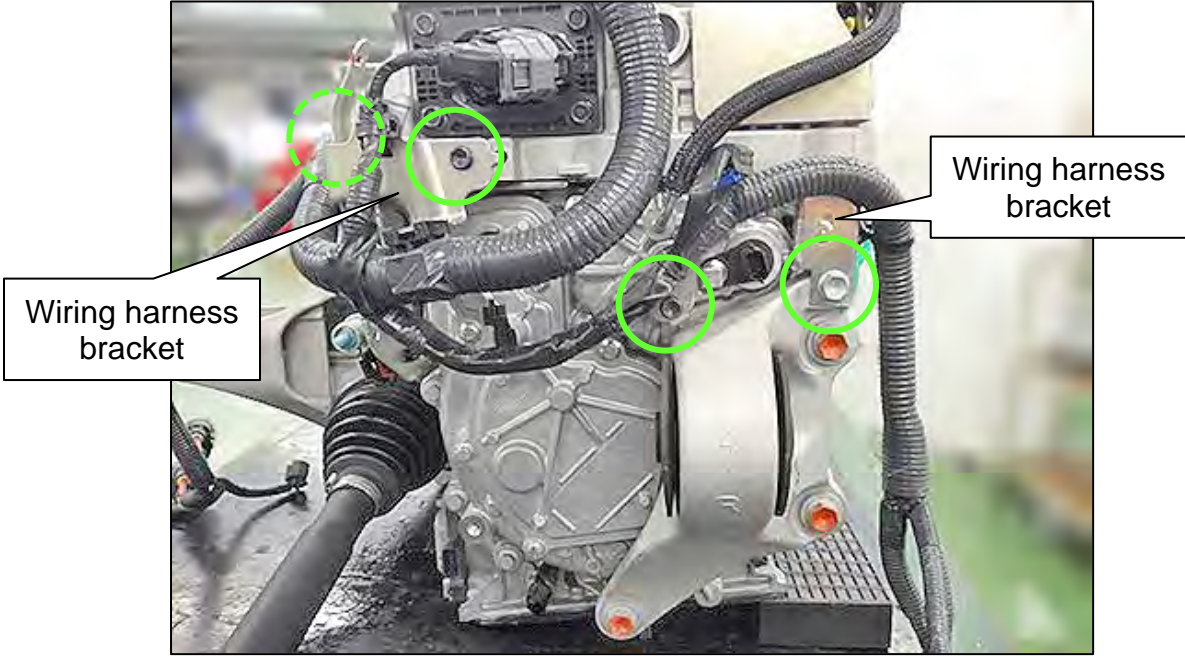

Figure 122

145. Attach the passenger (RH) side wiring harness into its four (4) harness clamps.

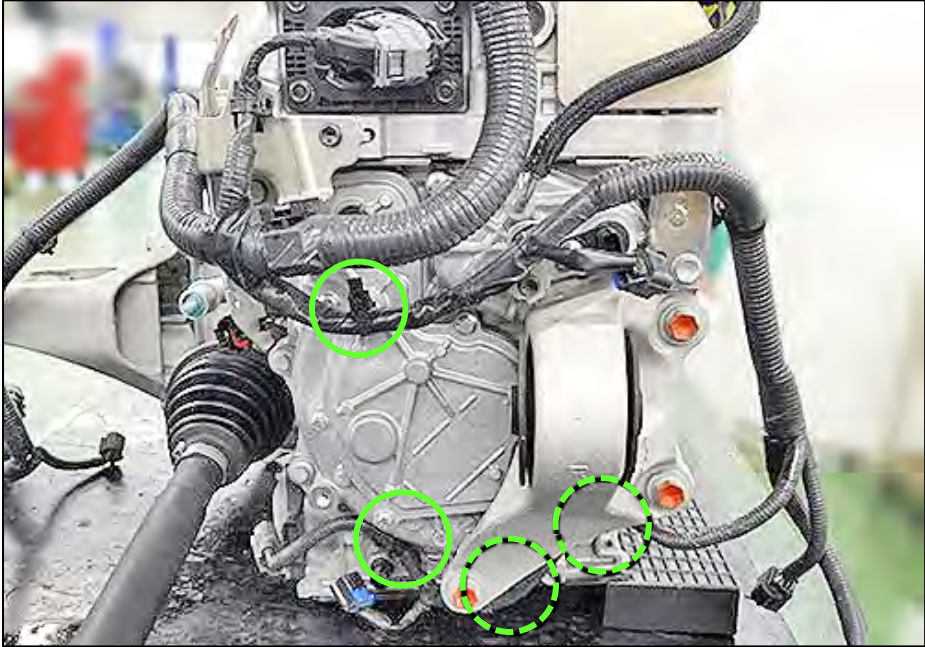

Figure 123



146. Connect the four (4) passenger (RH) side wiring harness connectors into their related components.

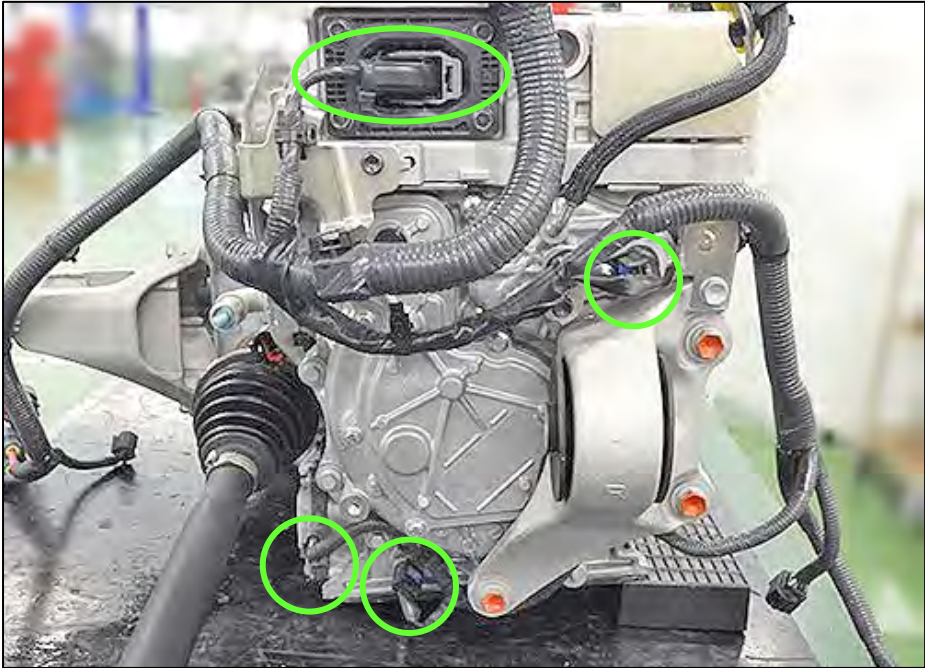

Figure 124

147. Attach the front wiring harness into its five (5) harness clamps, and then connect the harness connector shown in Figure 125.

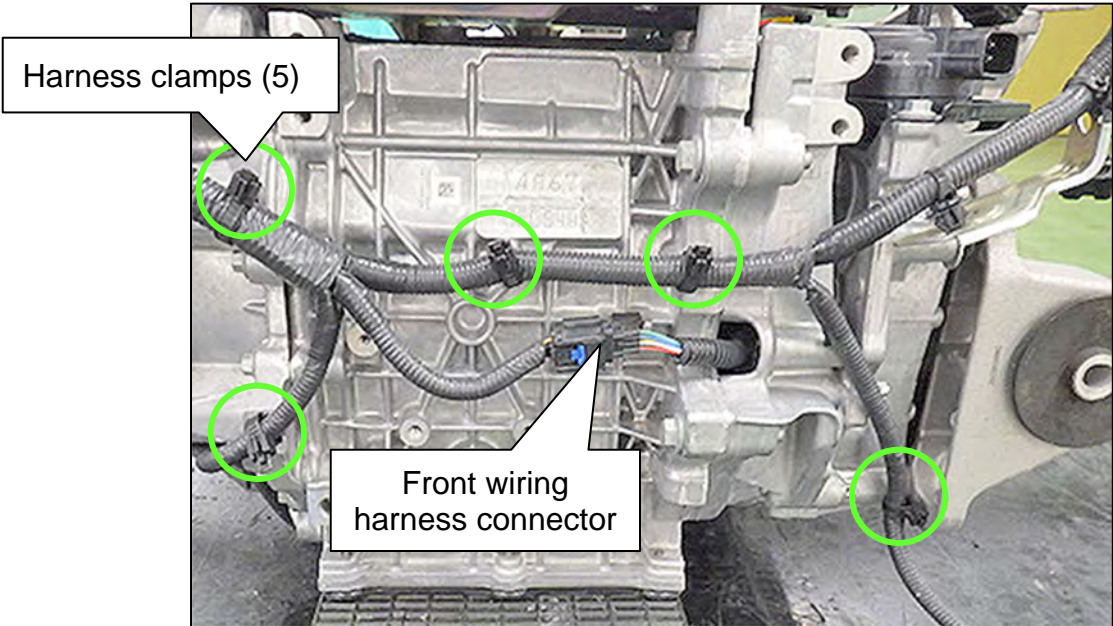

Figure 125

148. Connect the Parking Actuator wiring harness connector on the driver (LH) side, and then secure the three (3) wiring harness clamps.

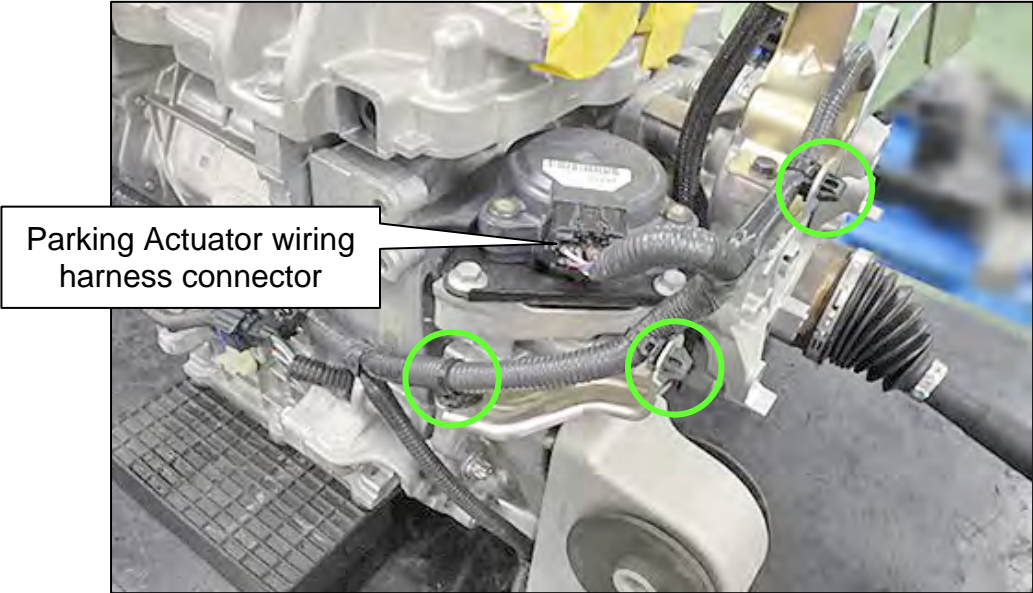

Figure 126

149. Write down the front Traction Motor's resolver correction value (A) and rotor resistance value (B) on the repair order (Figure 127).

**IMPORTANT:** When replacing a Traction Motor, it is necessary to write the Traction Motor resolver correction value and rotor resistance value to the vehicle for correct operation.

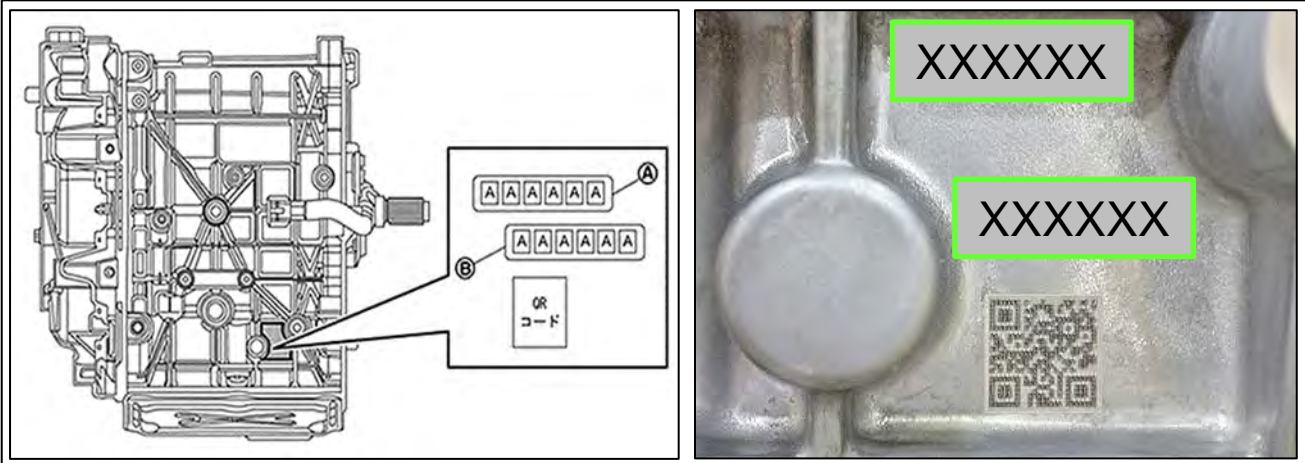

Figure 127



## Attach the Front Traction Motor, Inverter and Reduction Gear to the Front Suspension Member

150. Install the engine slingers at three (3) points on the Traction Motor.

151. Attach two (2) sling belts to the engine slingers.

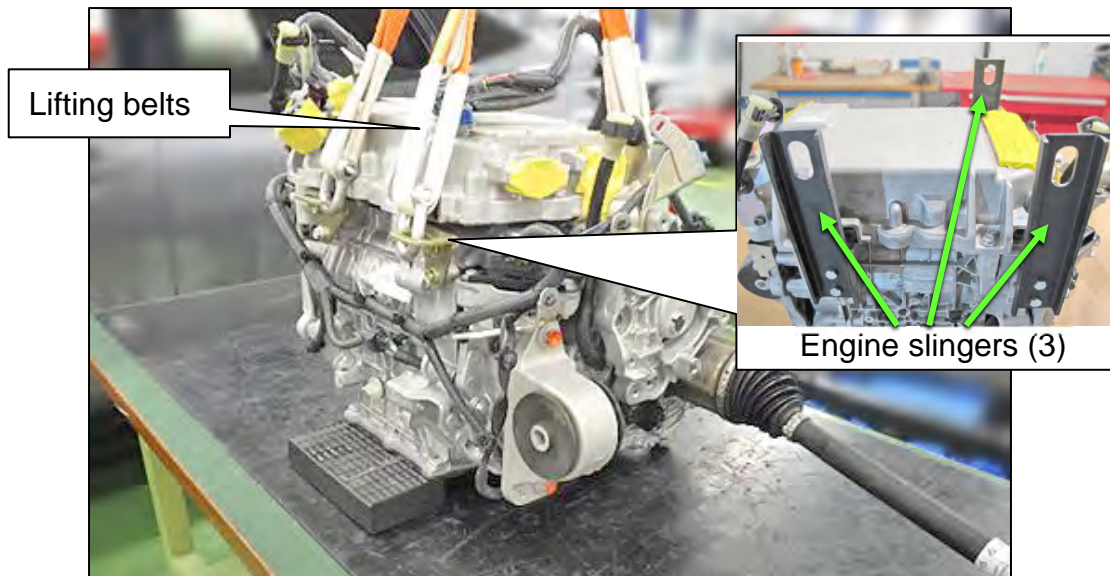

Figure 128

152. Lift the Traction Motor, Inverter, and Reduction Gear assembly with an engine hoist, and then move them to the Suspension Member.



Figure 129

153. Align the three (3) Motor Mounts of the Traction Motor assembly with the Suspension Member, and then install the bolts and nuts to the motor mounts (3 locations).
- Torque bolts to 105.0 N•m (11.0 kg-m, 77 ft-lb).

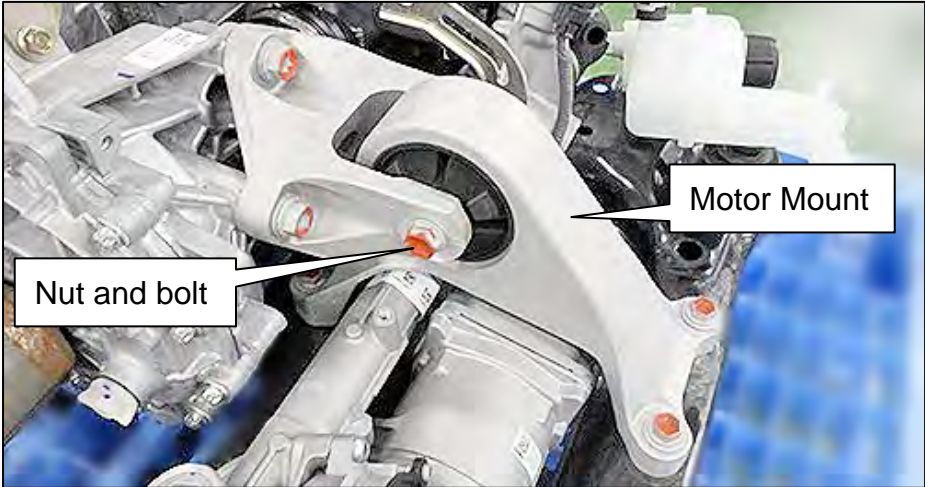

Figure 130

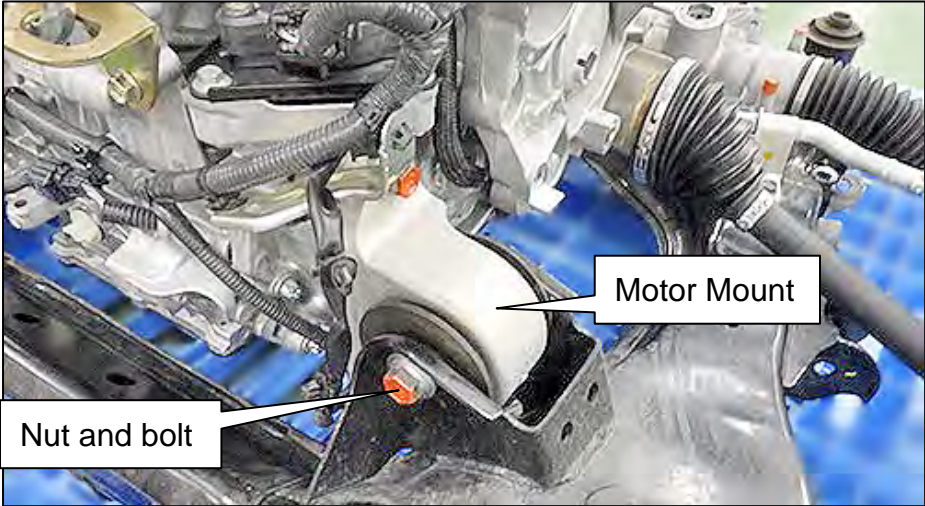

Figure 131



Figure 132



- 154. Remove the engine slingers (three locations) and move the engine hoist out of the way.
- 155. Confirm that the clearance of each Motor Mount (3 locations) is within A and B.
  - A dimensions: 11.0 +/- 1.0 mm
  - B dimension: 10.0 ± 1.0 mm

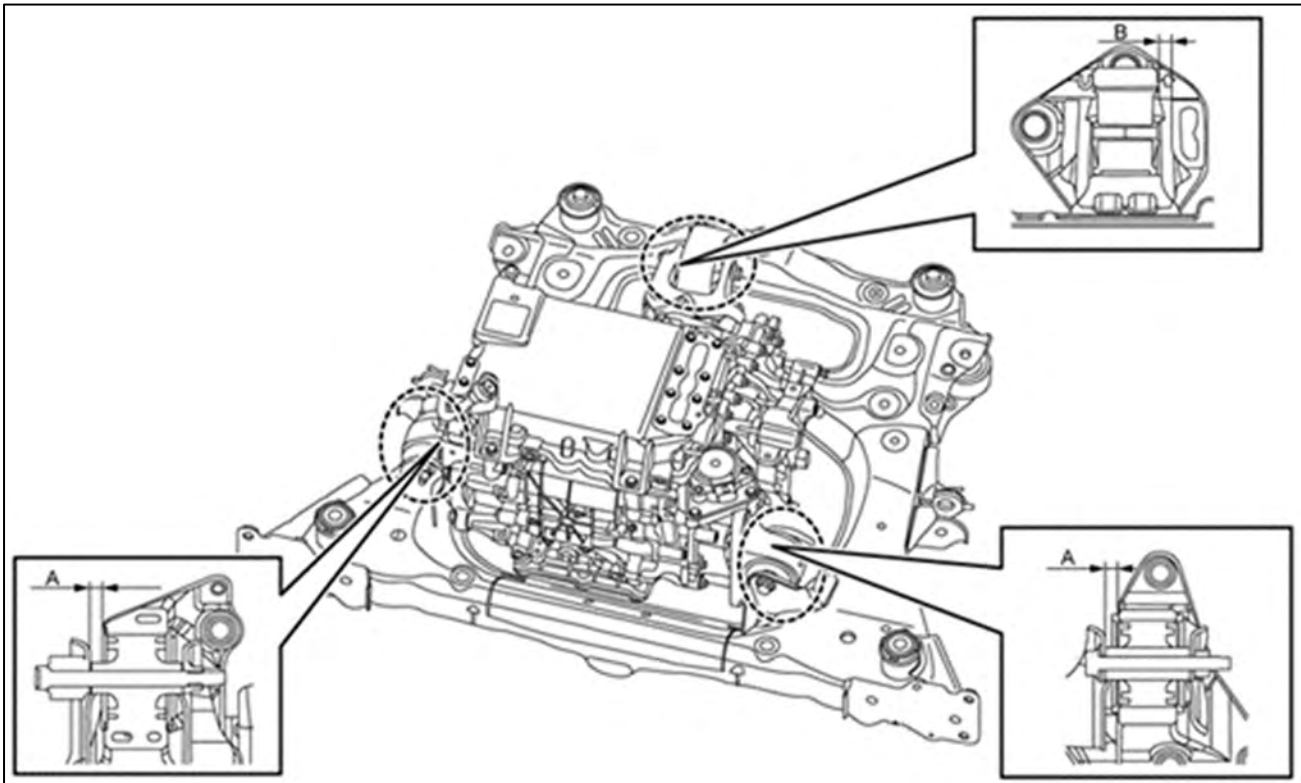

Figure 133

- 156. Connect the four (4) wiring harness plugs of the Electric Power Steering where shown in Figure 134.
- 157. Attach the two (2) Electric Power Steering wiring harness clips (1 hidden in Figure 134).

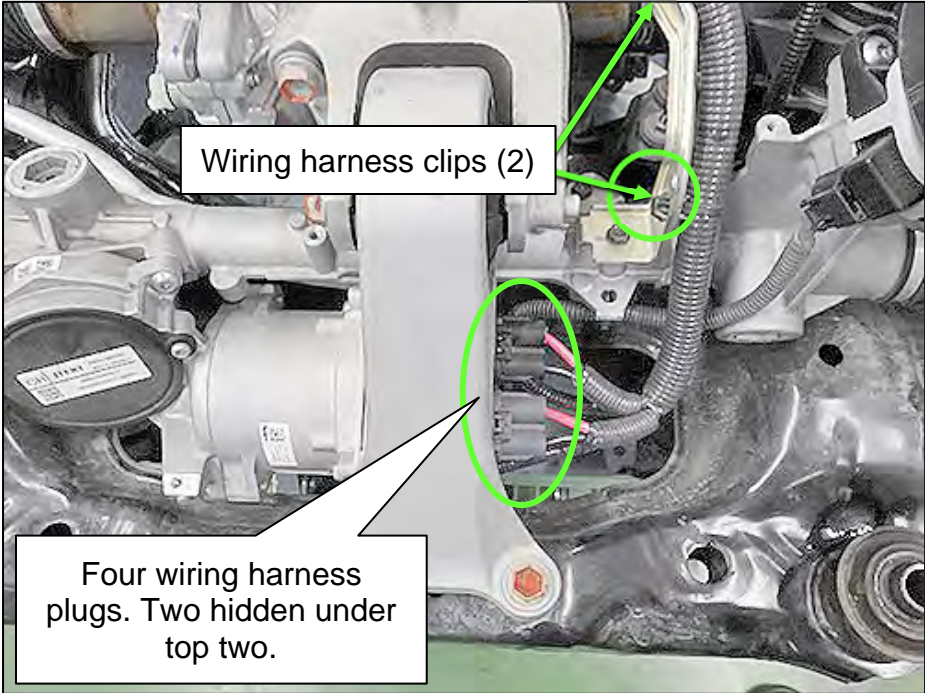

Figure 134

- 158. Connect the Electric Water Pump wiring harness connector, and then the Electric Water Pump harness clip to the bracket.

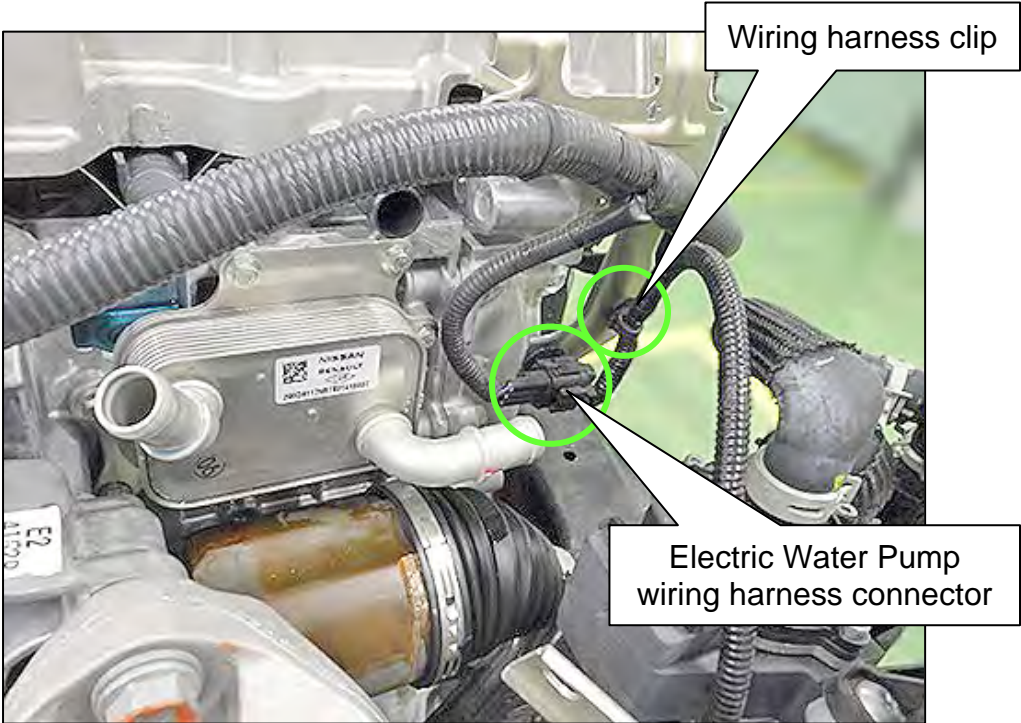

Figure 135



## Connect the Water Hoses

159. Install the Traction Motor Inlet Hose, shown in Figure 136.

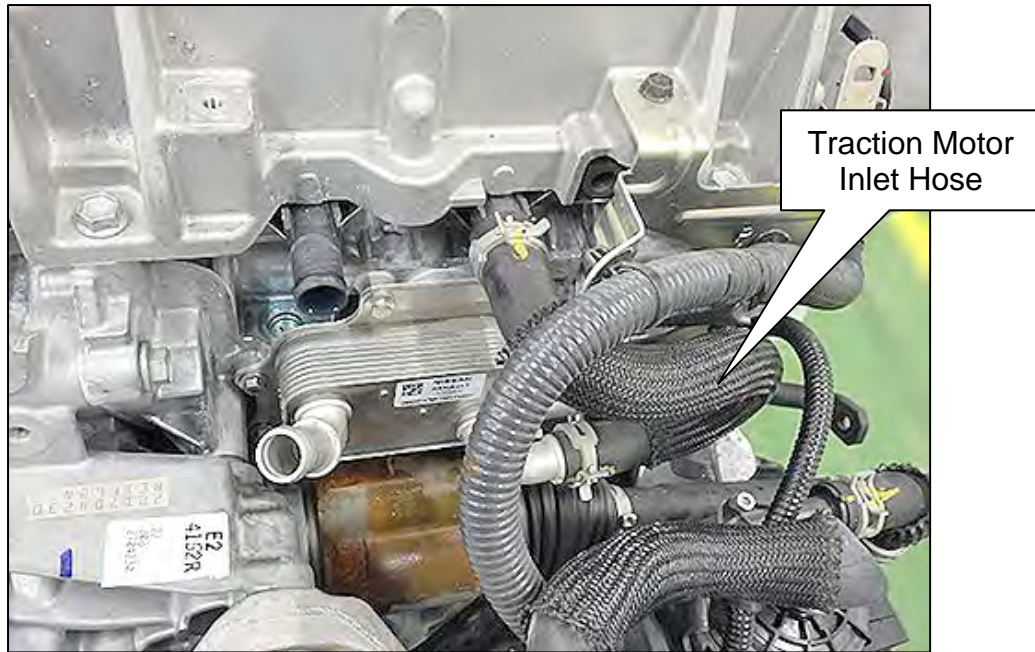

Figure 136

160. Install Radiator Hose Lower (Figure 137).

161. Attach the two (2) hose brackets shown in Figure 137.

- Torque bolts to 8 N•m (0.62 kg-m, 71 in.-lbs).

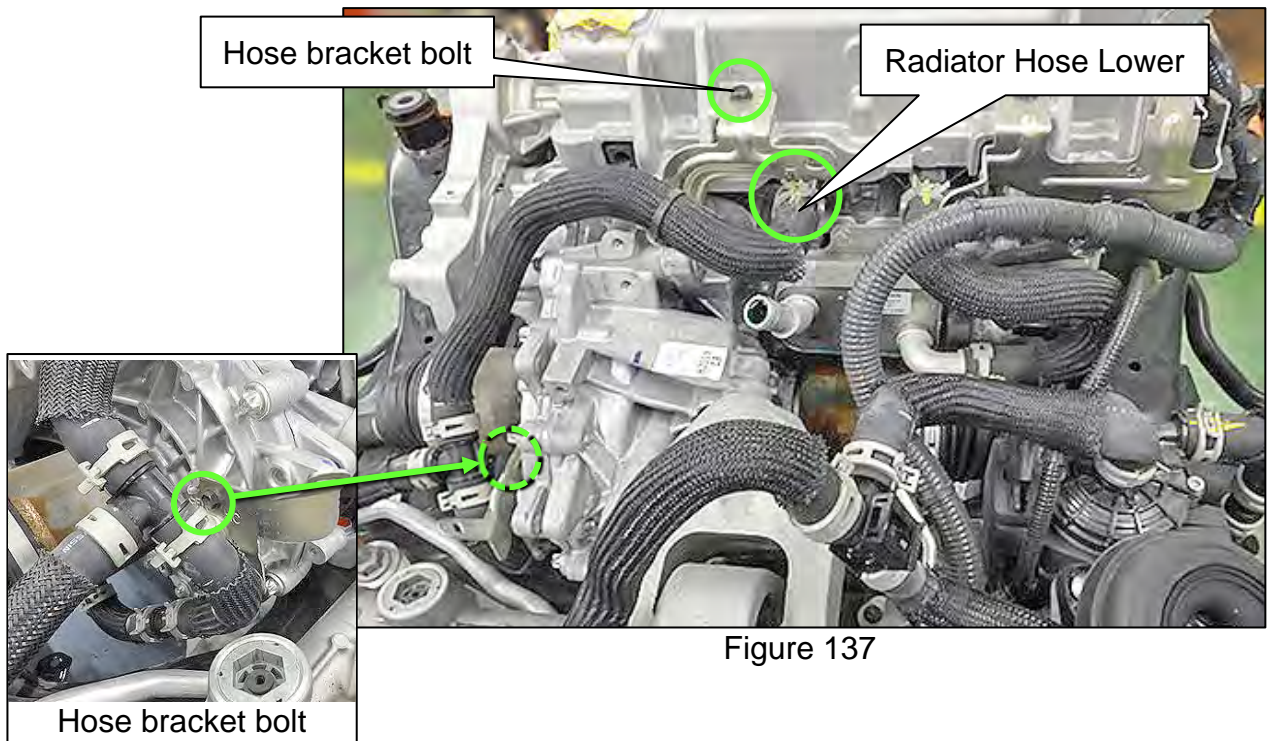

Figure 137

162. Connect the Traction Motor Inlet Hose 3-way connector to its bracket (Figure 138).

163. Connect the Traction Motor Inlet Hose (traction motor side) on the left side of the water cooler.

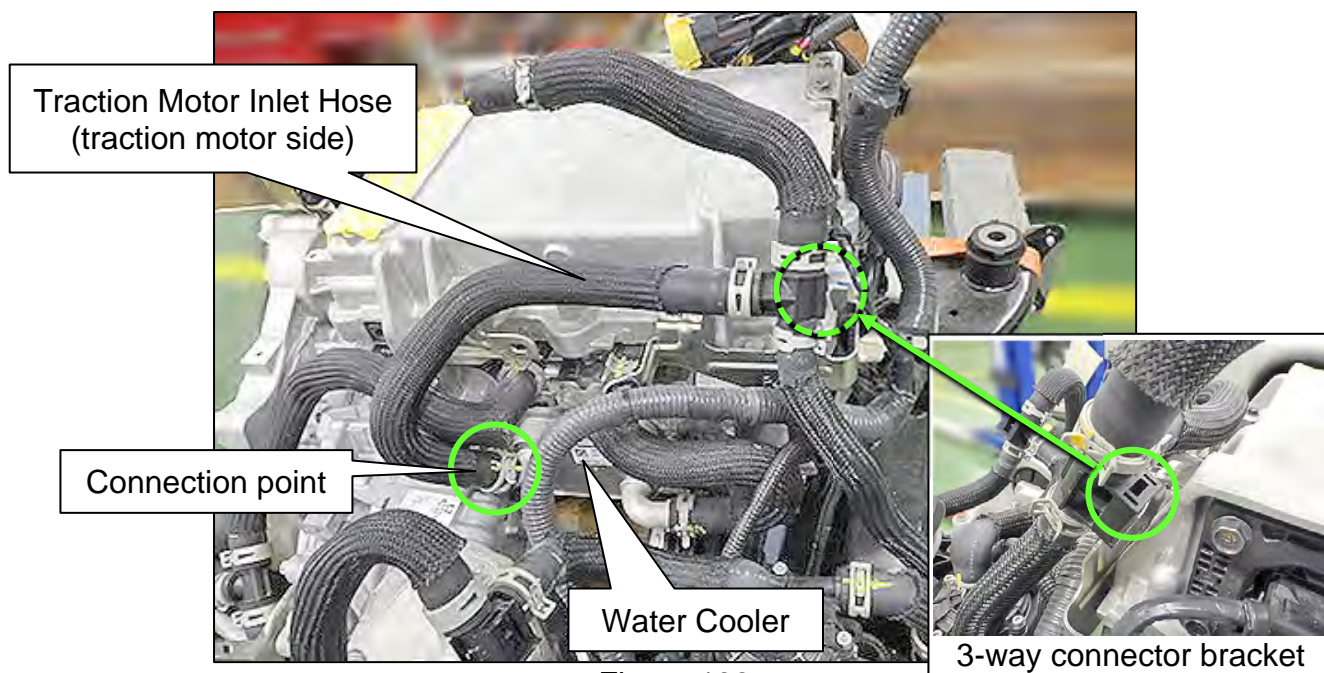

Figure 138

**Install the Front Suspension Member to the Vehicle** (with front drive motor, Inverter and reduction gear assembly)

164. Move the Front Suspension Member assembly to the underside of the vehicle (Figure 139).

165. Remove any devices that were used to secure the Front Suspension Member to the powertrain lift.



Figure 139



166. Raise the Front Suspension Member with Traction Motor carefully into the vehicle.

- Raise the powertrain lift while paying attention to interference with each part.

167. Install the front bolts **finger tight** to help guide alignment.

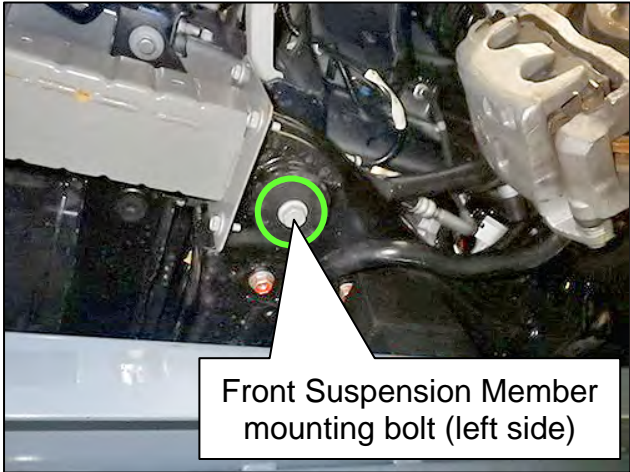

Figure 140

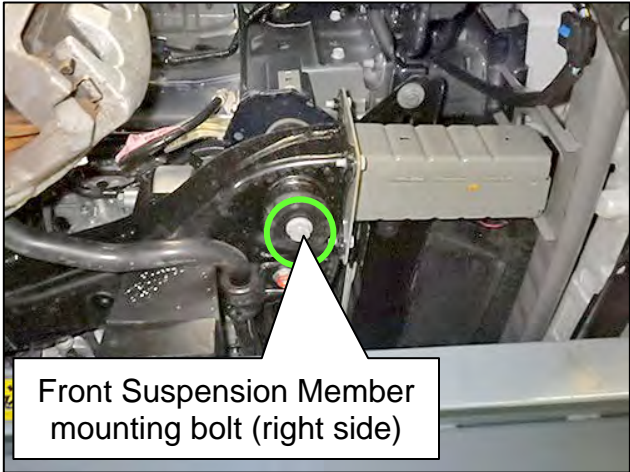

Figure 141

168. Place each Front Drive Shaft onto their related transverse links (Figure 142).



Figure 142

169. Install the Front Member Stay (right side) and the Front Member Stay (left side) into the vehicle, and then install the related mounting bolts of each **finger tight**.

- Six (6) bolts.

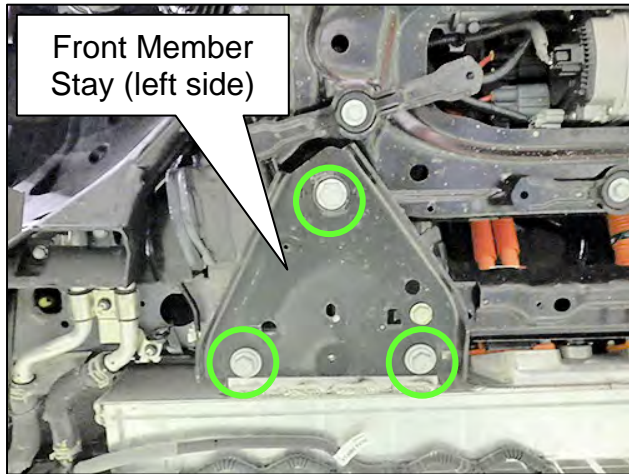

Figure 143

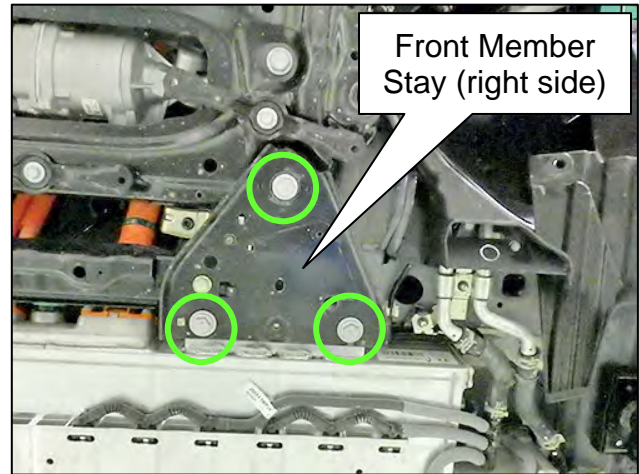

Figure 144

170. Lightly tighten the Front Suspension Member mounting bolts, and then tighten them with the specified torque in the following order (Figure 145):

- a. Lightly tightening order: 1 → 2 → 3 → 4
- b. Specified torque tightening order: 5 → 6 → 7 → 8
  - Torque bolts to 180 N•m (18.4 kg-m, **133 ft-lb**).

171. Tighten the four (4) rear Member Stay bolts to the specified torque.

- Torque bolts to 105 N•m (10.7 kg-m, **77 ft-lb**).

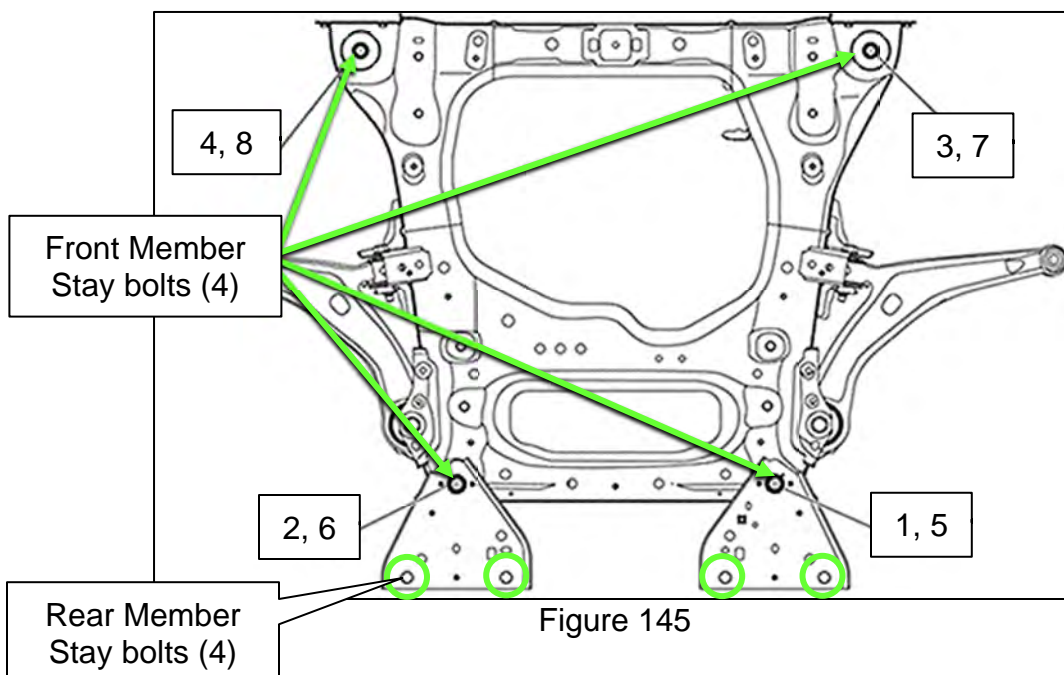

Figure 145



172. Install the high voltage harness bolt.

- Torque bolt to 21 N•m (2.1 kg-m, **15 ft-lb**).

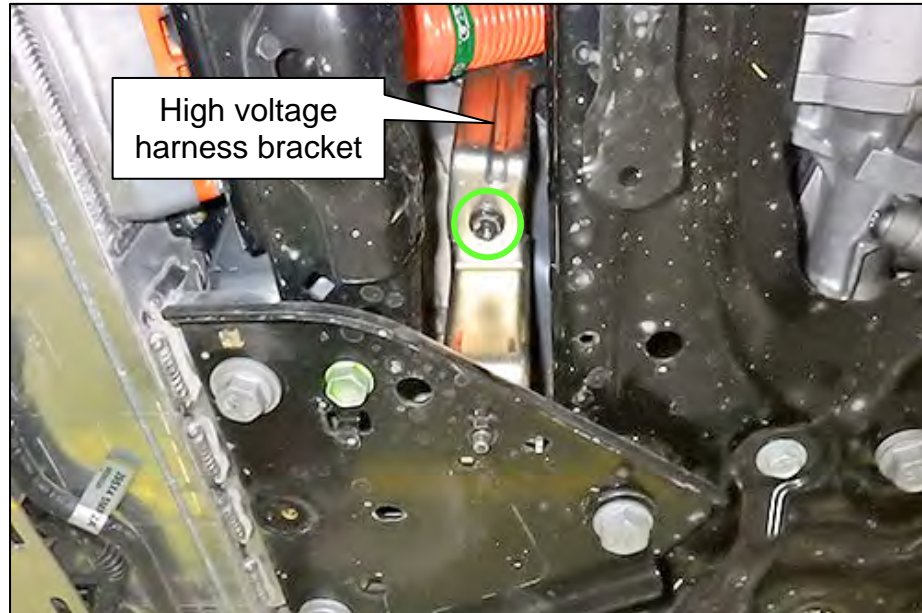

Figure 146

173. Lower the powertrain lift and relocate it outside the work space.

174. Install the Electric Water Pump.

- Two (2) bolts.
- Torque bolts to 21 N•m (2.1 kg-m, **15 ft-lb**).

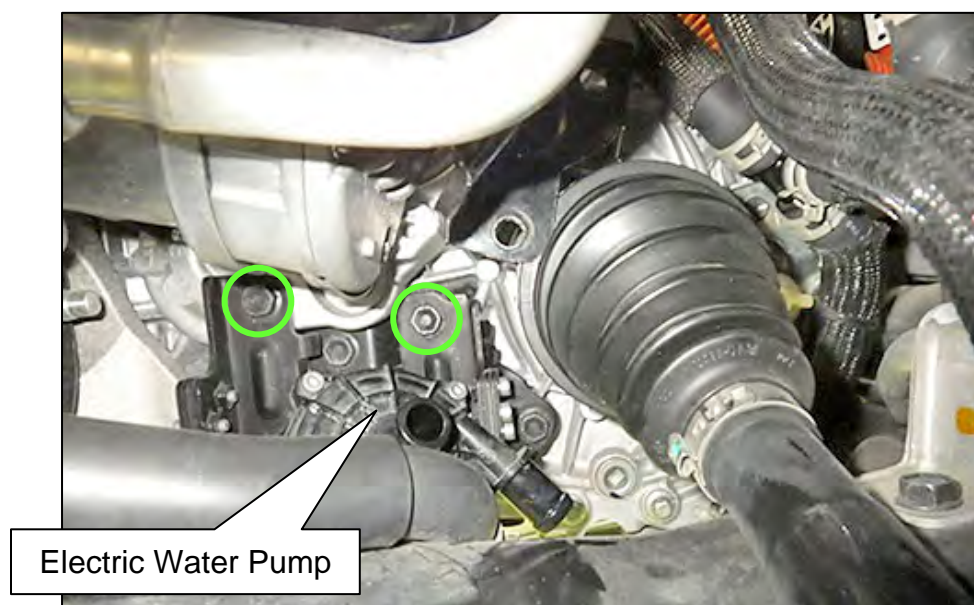
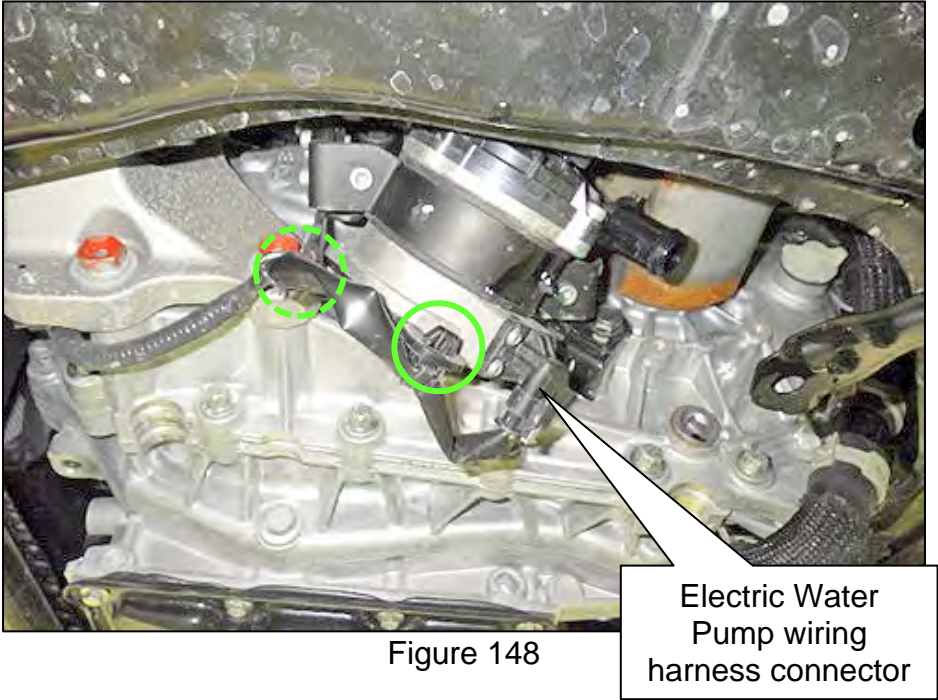

Figure 147

175. Attach two (2) wiring harness clips (Figure 148).

176. Connect the wiring harness connector to the Electric Water Pump.



177. Connect both coolant hoses to the Electric Water Pump.

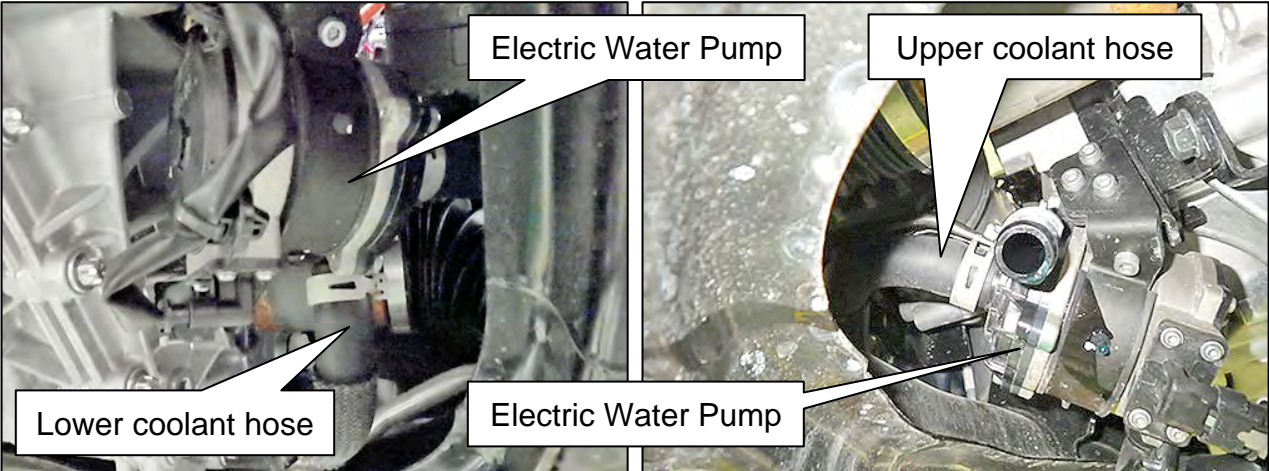



178. Connect the coolant hoses (water hoses) to the lithium-ion battery (Figure 151 and Figure 152).



Figure 151



Figure 152

## Install the Left Transversal Link

179. Lower the vehicle to a comfortable height to work with the Front Drive Shafts and Steering Knuckles.

180. Clean the contact surface (A), shown in Figure 153, between the Steering Knuckles and the Front Drive Shafts, and then apply the following amount of Molykote M-77.

- Molykote part number 44003-7S000
- Molykote coating amount: 1.0 to 3.0 g

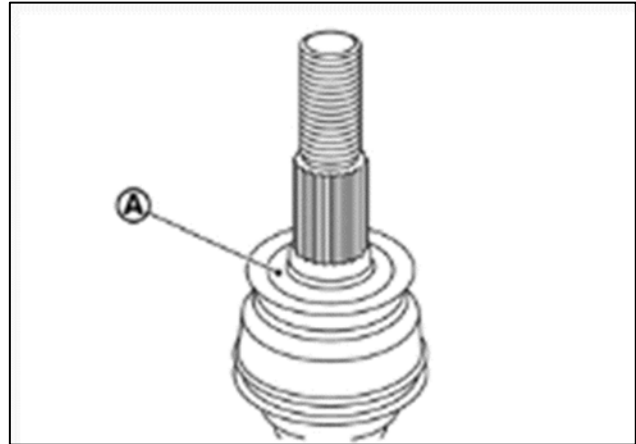

Figure 153

181. Insert the passenger (RH) side Front Drive Shaft into its Steering Knuckle assembly.

**HINT:** Place the indentation of the draft shaft (A) between the wheel studs (B). This will allow easy access to stake the lock nut later in this procedure.

**IMPORTANT:** Do not install or torque the Front Drive Shaft lock nuts. This will be completed later in this procedure.

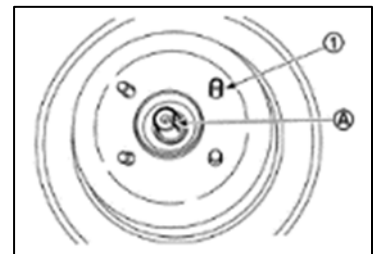

Figure 154

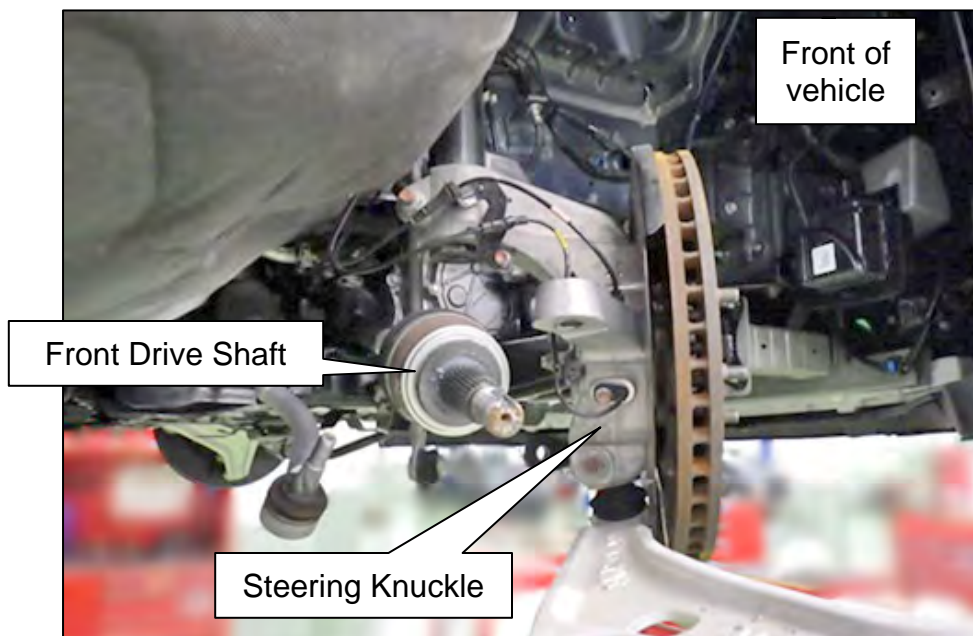

Figure 155



182. Attach the passenger (RH) side Transverse Link to the Front Suspension Member.
- a. Align the front horizontal Transverse Link's attachment point to the Front Suspension Member, and then install the bolt and nut **finger tight**.
    - Replace the nut with a new one from **PARTS INFORMATION** on page 110.
  - b. Place a jack under the passenger (RH) side ball joint and raise the ball joint until the rear vertical Transverse Link's attachment point aligns with the Front Suspension Member, and then install the bolt and nut **finger tight**.
    - Replace the nut with a new one from **PARTS INFORMATION** on page 110.
  - c. Raise the jack again to load suspension.
  - d. Tighten both bolts to their specified torque:
    - Torque front bolt to 175 N•m (18 kg-m, **129 ft-lb**).
    - Torque rear bolt to 190 N•m (19 kg-m, **140 ft-lb**).

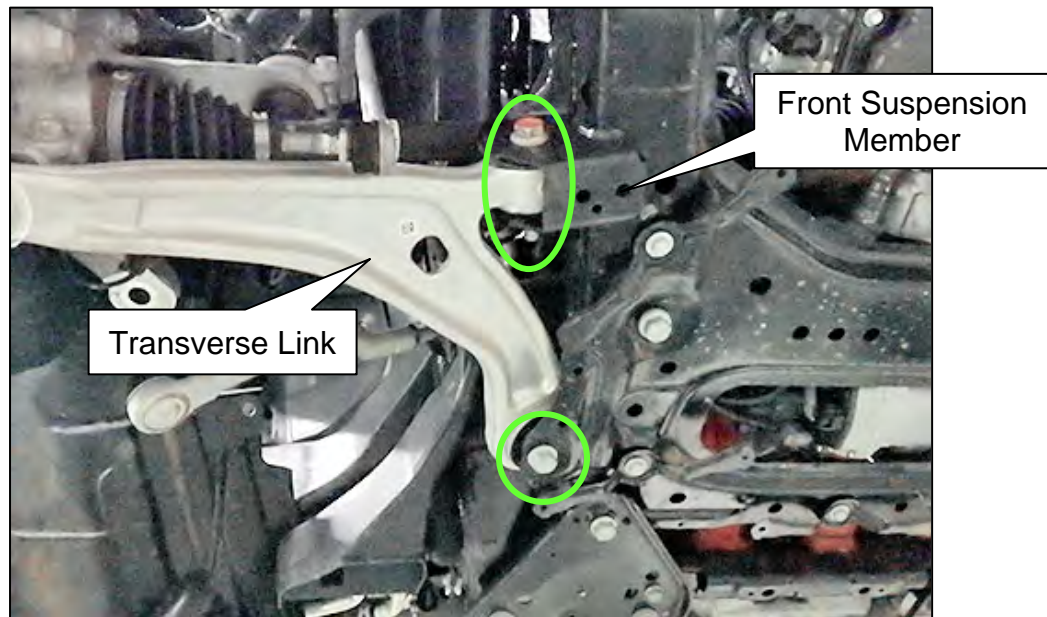

Figure 156

183. Remove the jack and reconnect the Stabilizer Connecting Rod to the Stabilizer Bar Assembly.

- Torque nut to 74 N•m (7.5 kg-m, **55 ft-lb**).

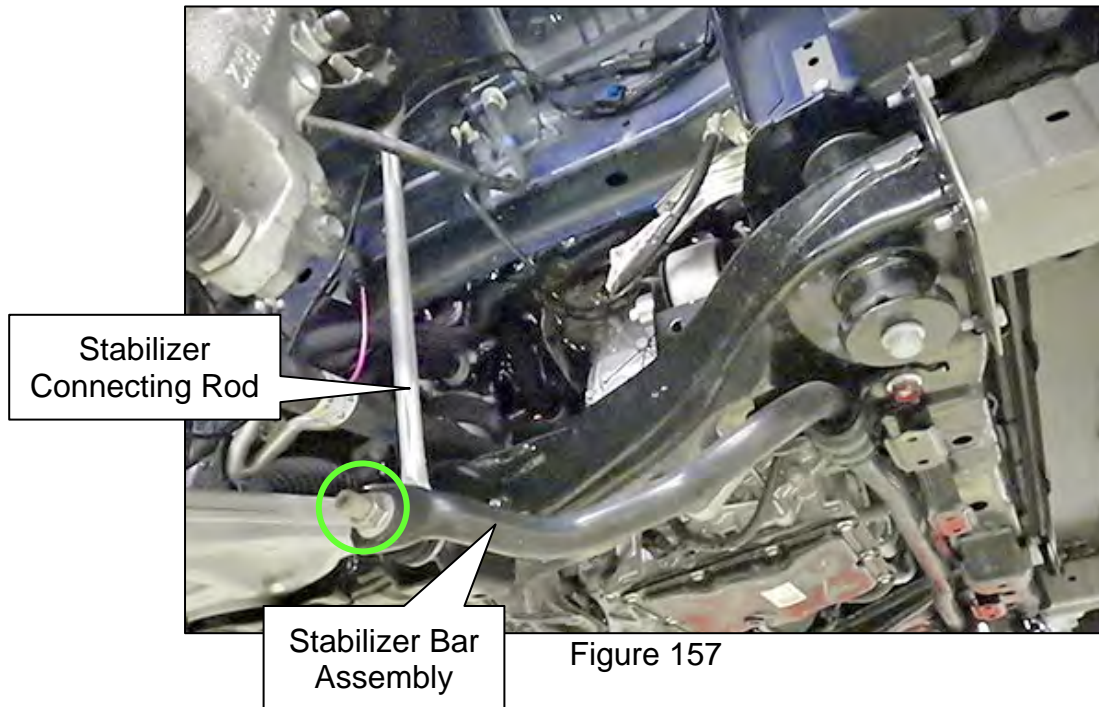

Figure 157

184. Attach the steering Outer Socket to the Steering Knuckle with new nuts.

- Refer to **PARTS INFORMATION** on page 110.
- Torque nuts to 54.5 N•m (5.6 kg-m, **40 ft-lb**).

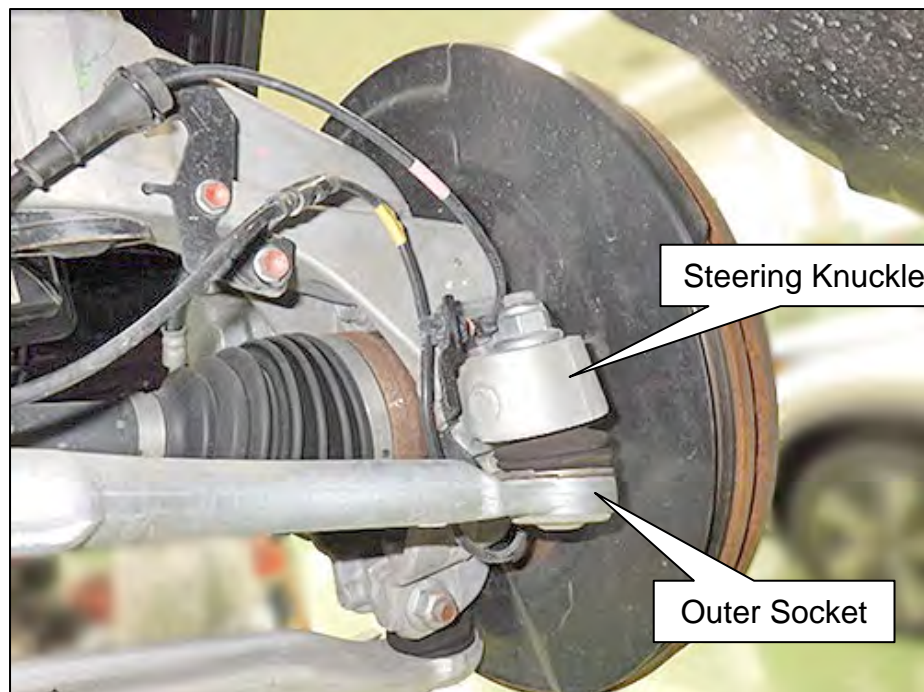

Figure 158



185. Attach the brake hose to its bracket, and then install the lock plate.



Figure 159

186. Install the passenger (RH) side Wheel Speed Sensor wiring harness connector.

- a. Attach the grommet to its bracket.
- b. Install the bolt.
  - o Torque bolt to 8 N•m (0.62 kg-m, **71 in.-lbs**).

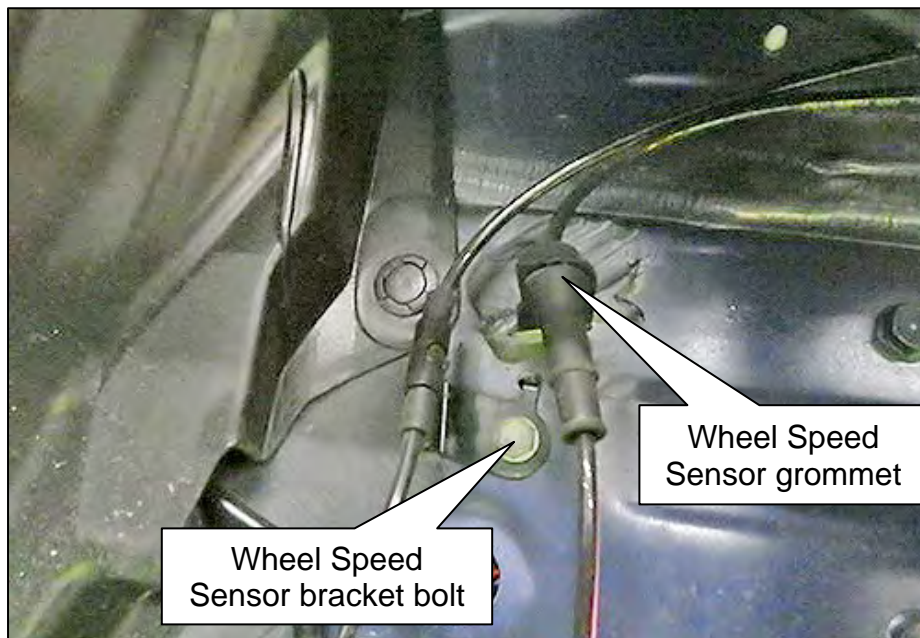

Figure 160

187. Repeat steps 180-186 on the driver (LH) side of the vehicle.

188. Attach the ground cable on the passenger (RH) side of the Traction Motor.

- Torque bolt to 21 N•m (2.1 kg-m, **15 ft-lb**).

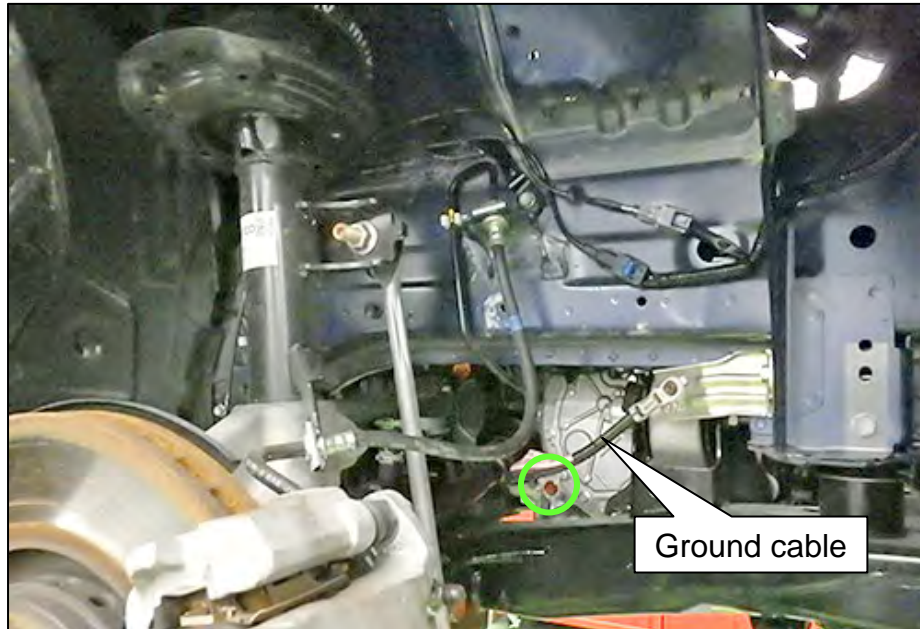

Figure 161

189. Install the passenger (RH) side upper Fender Protector.

- Eight (8) clips.
- Figure 162 below, and Figure 163 on page 82.

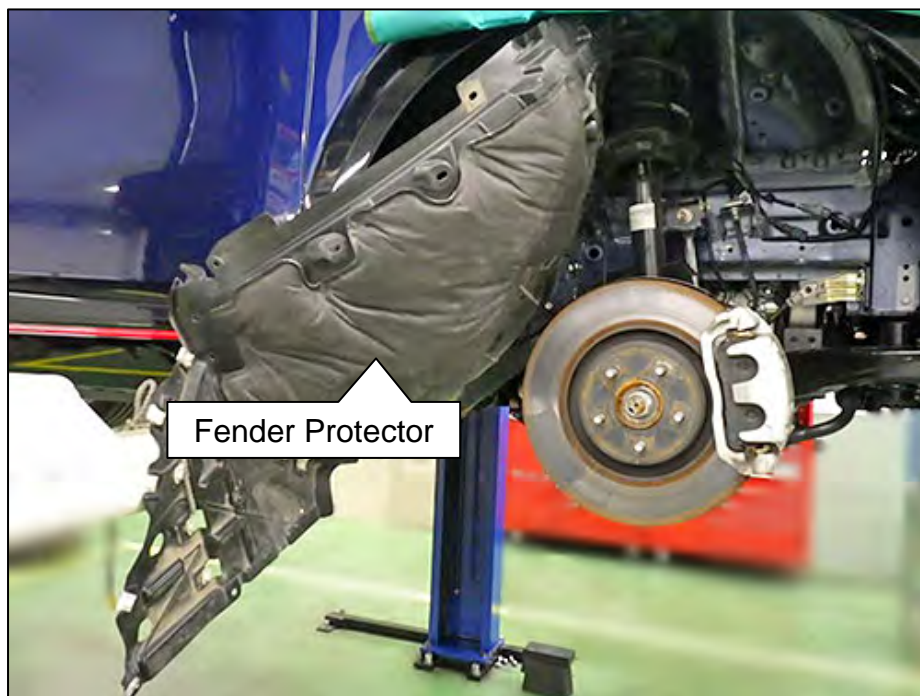

Figure 162



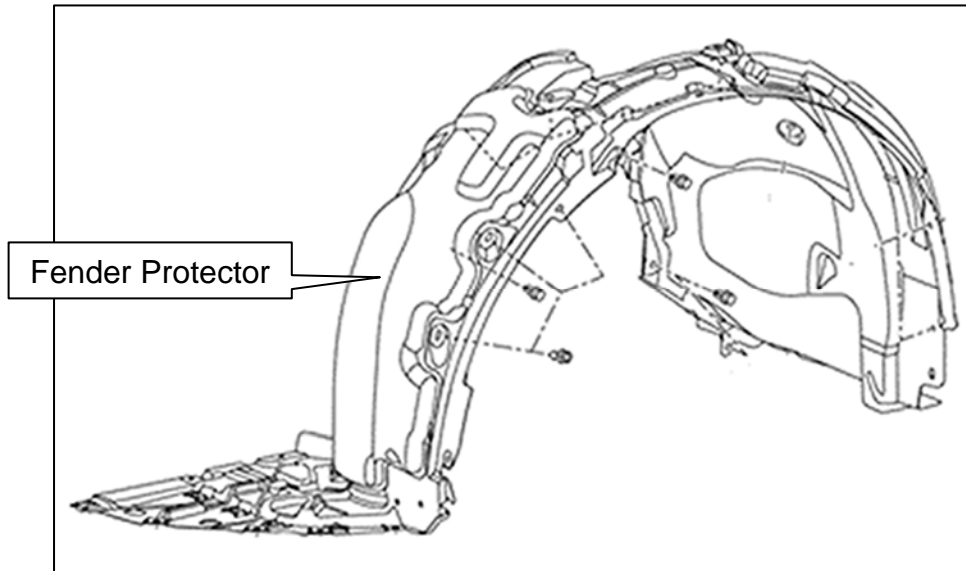

Figure 163

190. Install the front lower side of the passenger (RH) side Fender Protector.

- Eight (8) screws.

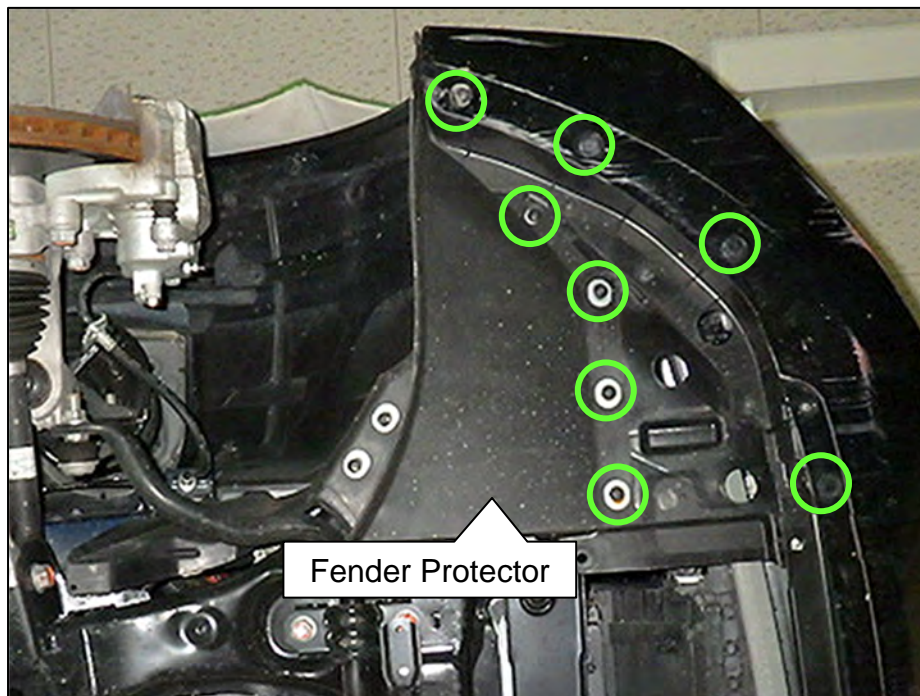

Figure 164

191. Install the passenger (RH) side Air Guide (Figure 165).

- Seven (7) screws and two (2) clips.

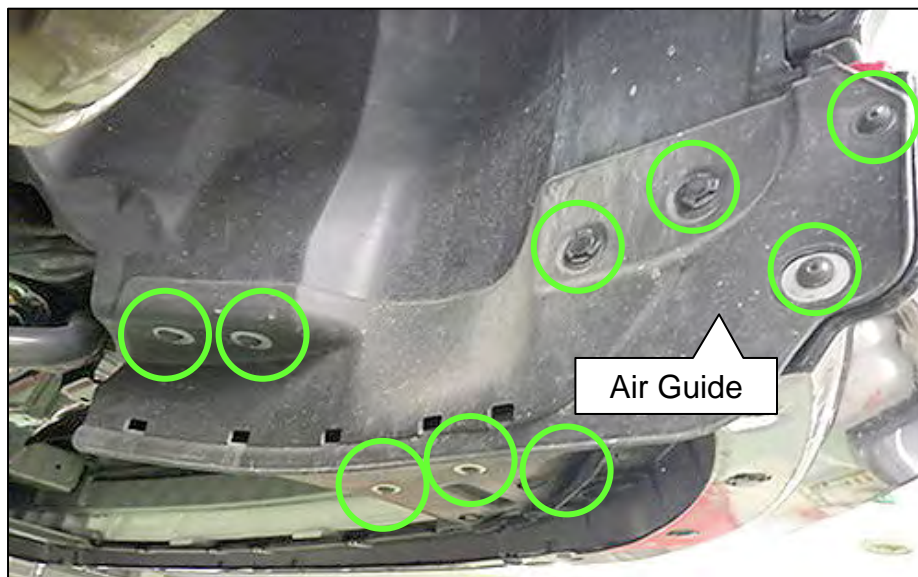

Figure 165

### Install the Right Reservoir Tank

192. Lower the vehicle to a comfortable level to work under the hood.

193. Attach the reservoir hose 3-way connector to its bracket (Figure 166).

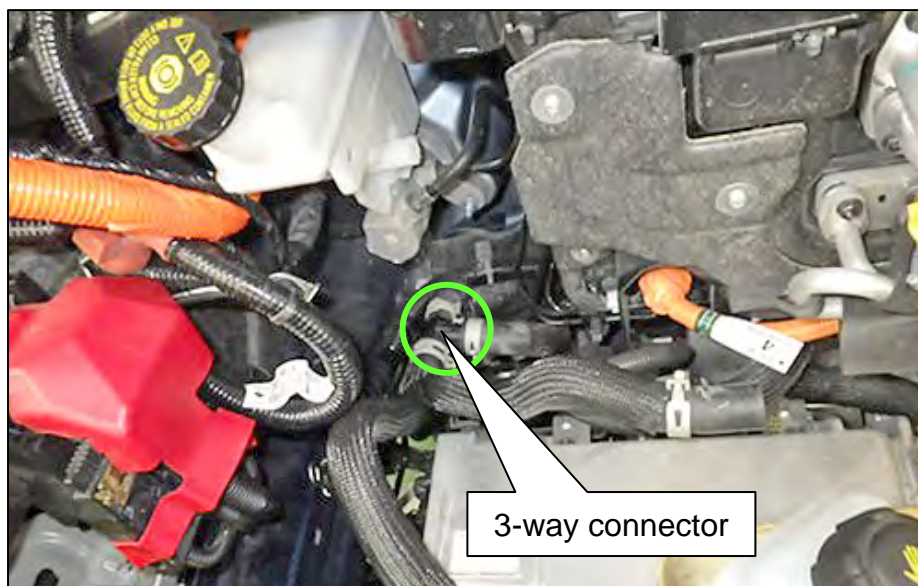

Figure 166



194. Install the passenger (RH) side coolant Reservoir Tank (for Li-ion battery).
- One (1) bolt.
  - Torque bolt to 4 N•m (0.4 kg-m, **35 in.-lbs**).



Figure 167

195. Remove the protective tape, and then connect the wiring harness connectors on the passenger (RH) side.

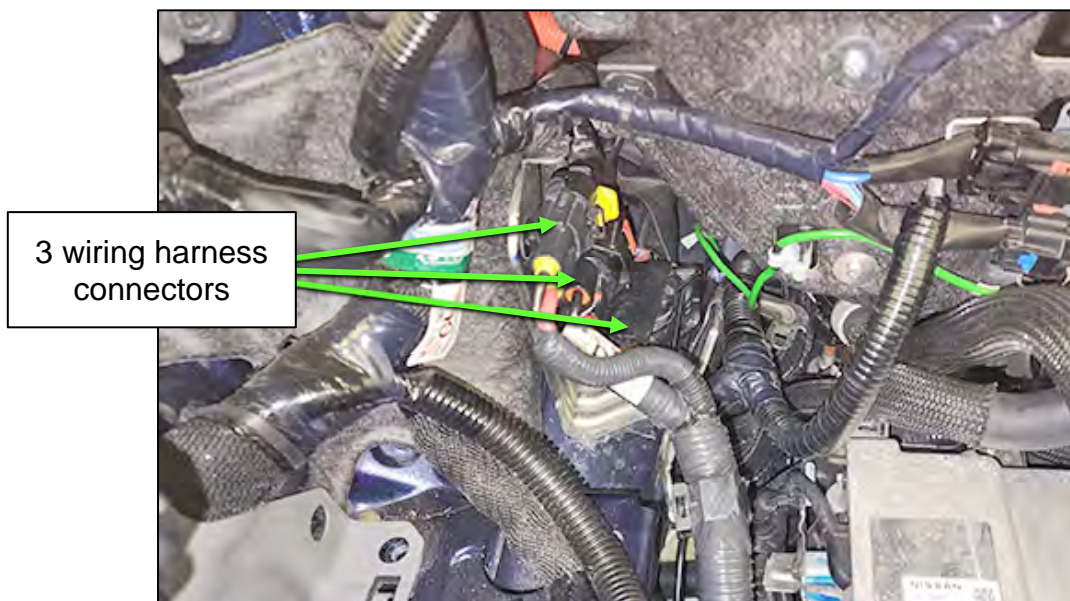

Figure 168

196. Attach the wiring harness clamp to its bracket (Figure 169).



Figure 169

197. Remove the strap used to secure the Electric Compressor to the vehicle.

198. Attach the Electric Compressor to its mount using the upper mounting bolt, **finger tight**.

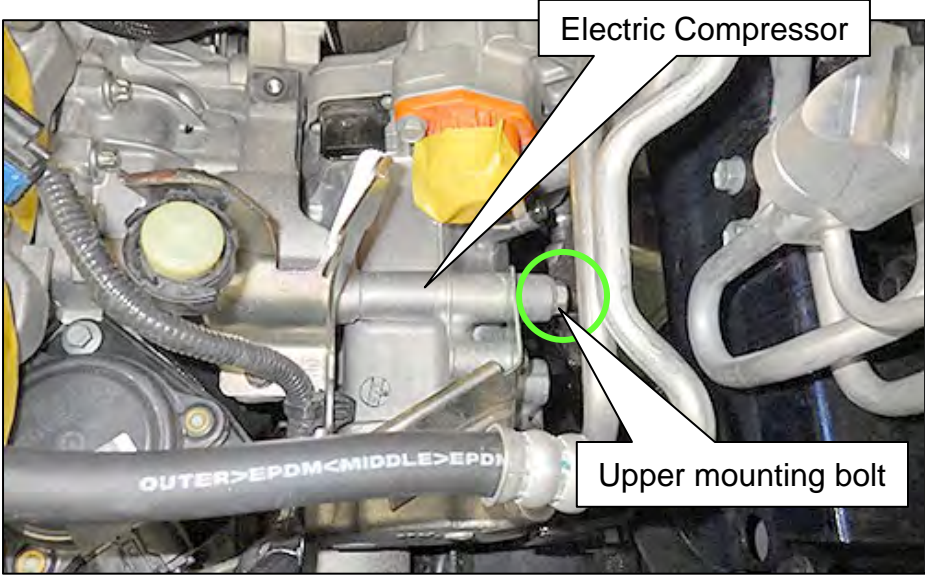

Figure 170



199. Raise the vehicle to allow access to the Electric Compressor mounting bolts through the driver (LH) side wheel area.
200. Install a second mounting bolt to the front of the Electric Compressor, **finger tight**.
201. Slide the Compressor Stay to the rear of the vehicle and install the rear mounting bolt of the Electric Compressor, **finger tight**.

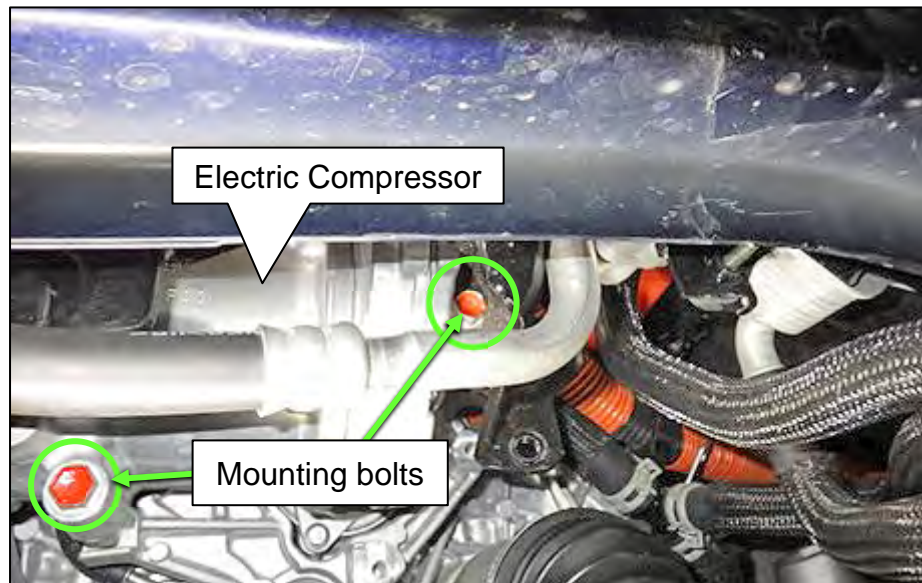

Figure 171

202. Tighten the front and rear mounting bolts of the Electric Compressor to the specified torque.
  - Torque bolts to 25 N•m (2.6 kg-m, **18 ft-lb**).
203. Lower the vehicle and then tighten the upper mounting bolt of the Electric Compressor to the specified torque.
  - Torque bolt to 25 N•m (2.6 kg-m, **18 ft-lb**).

204. Remove the protective tape and then connect the Electric Compressor's wiring harness connector.

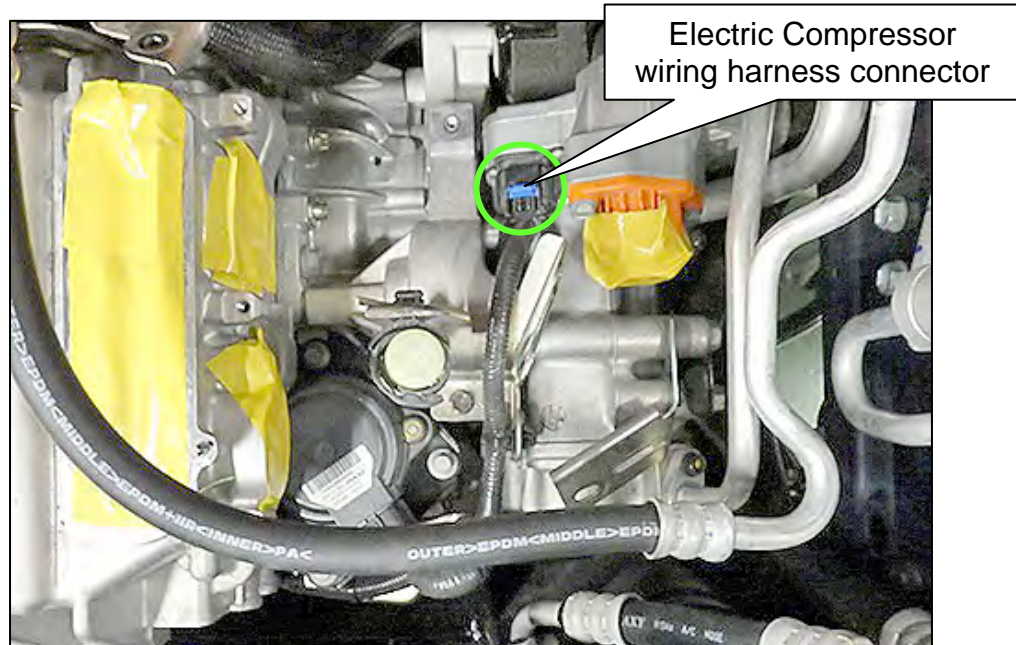

Figure 172

205. Raise the vehicle, attach the Compressor Sustain to the Electric Compressor with its four (4) mounting bolts, and then tighten to the specified torque.

- Torque bolts to 25 N•m (2.6 kg-m, 18 ft-lb).

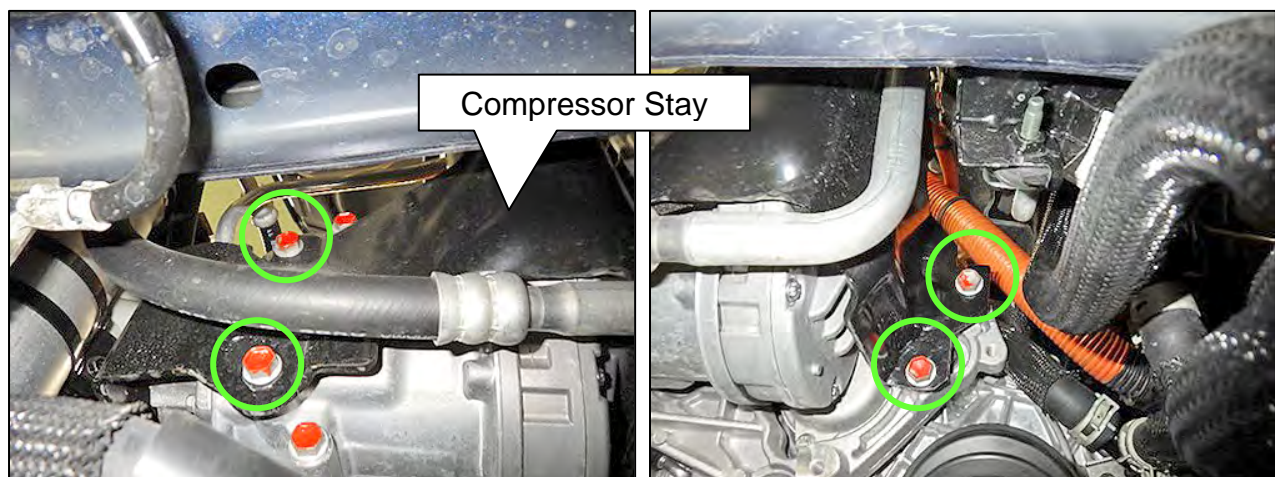

Figure 173

Figure 174



206. Attach the driver (LH) side ground cable to the Front Traction Motor.

- Torque bolt to 21 N•m (2.1 kg-m, **15 ft-lb**).

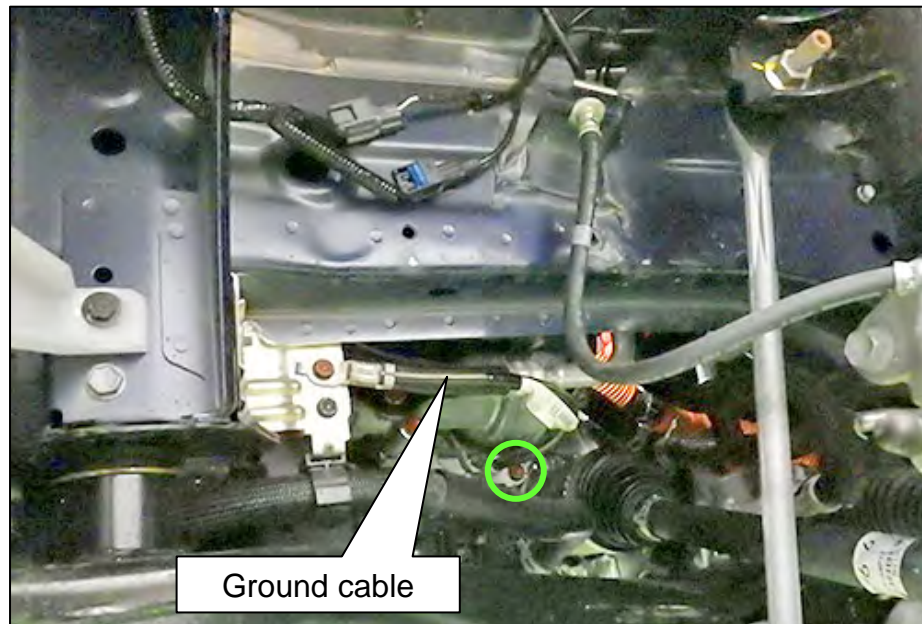

Figure 175

207. Install the driver (LH) side upper Fender Protector.

- Eight (8) clips.
- Figure 176 below, and Figure 177 on page 89.

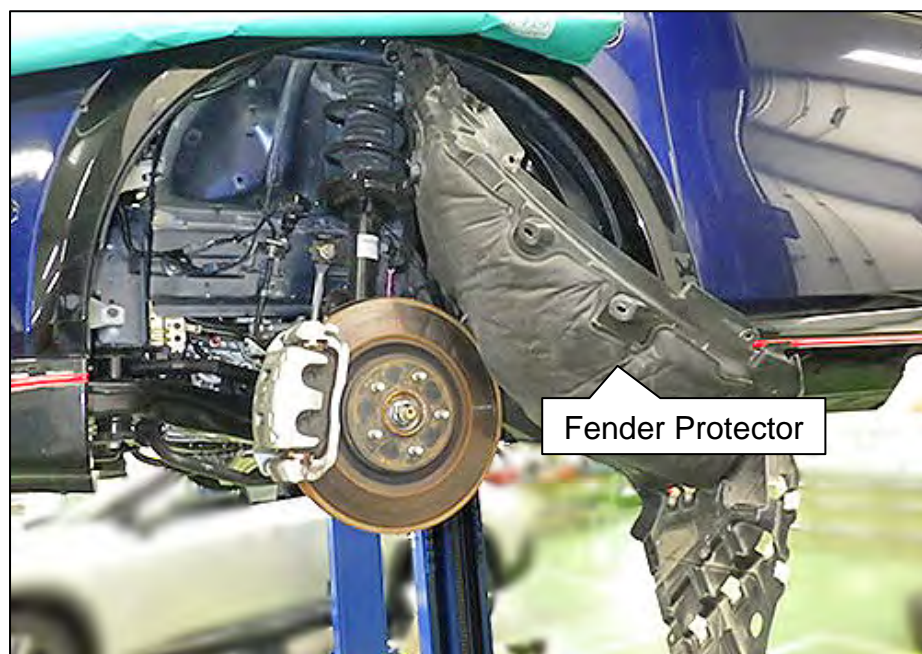

Figure 176

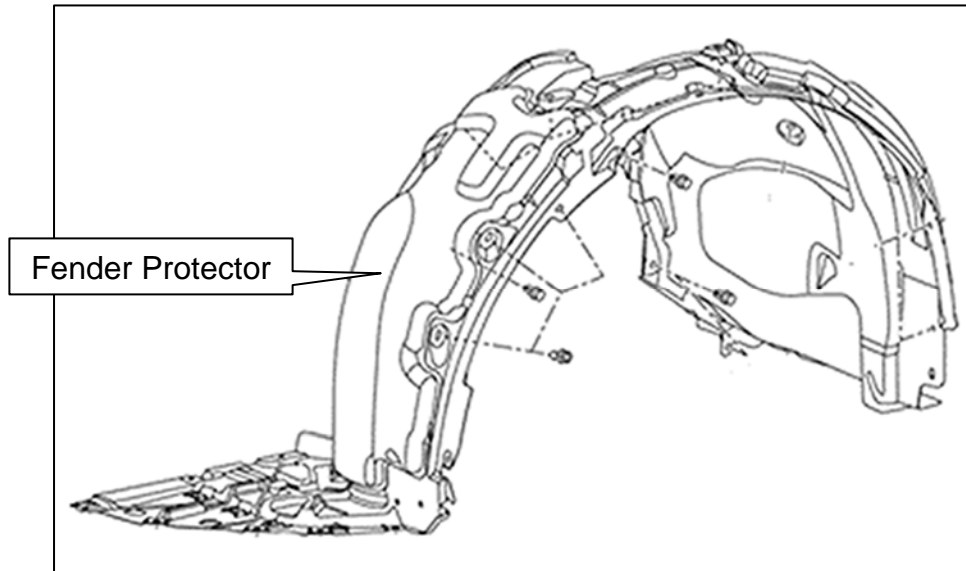

Figure 177

208. Install the front lower side of the driver (LH) side upper Fender Protector.
- Eight (8) screws.

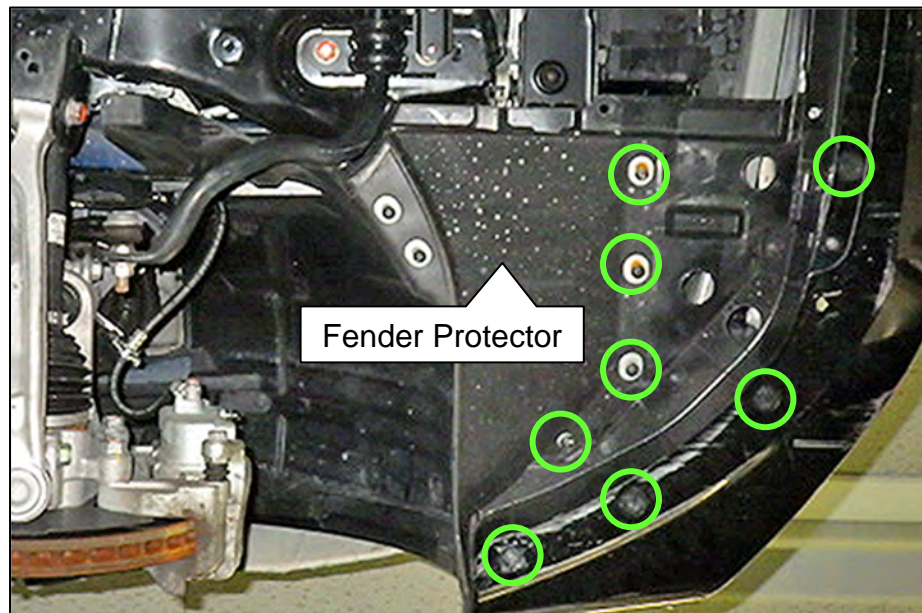

Figure 178



209. Install the driver (LH) side Air Guide (Figure 179).

- Seven (7) screws and two (2) clips.

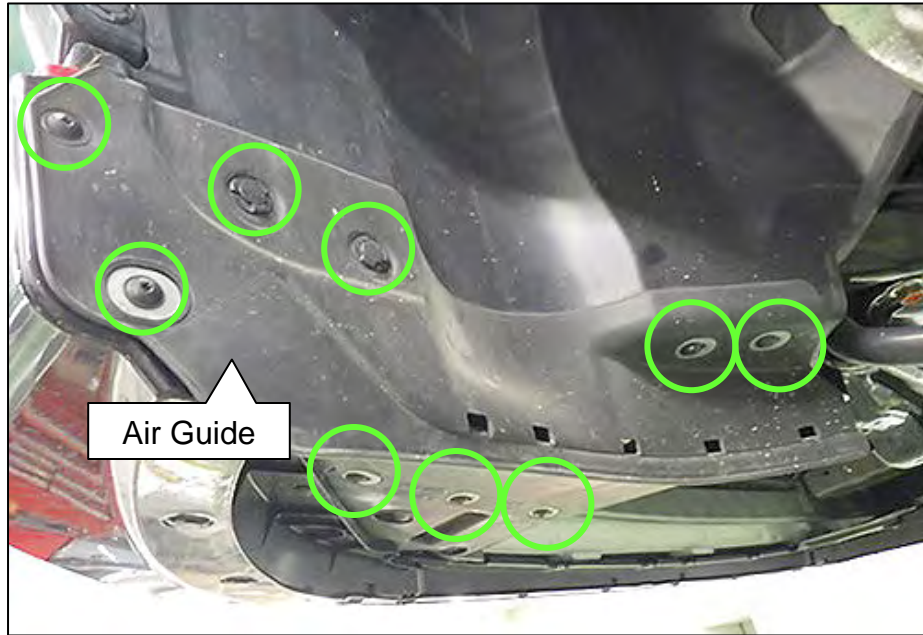

Figure 179

210. Lower the vehicle to a comfortable level to work under the hood.

211. Match the index mark that was created in step 38 on the High-Pressure Flexible Hose's "surge tank", and then attach the Surge Tank bracket.

- Two (2) bolts shown in Figure 181.
- Torque bolts to 8 N•m (0.62 kg-m, **71 in.-lbs**).

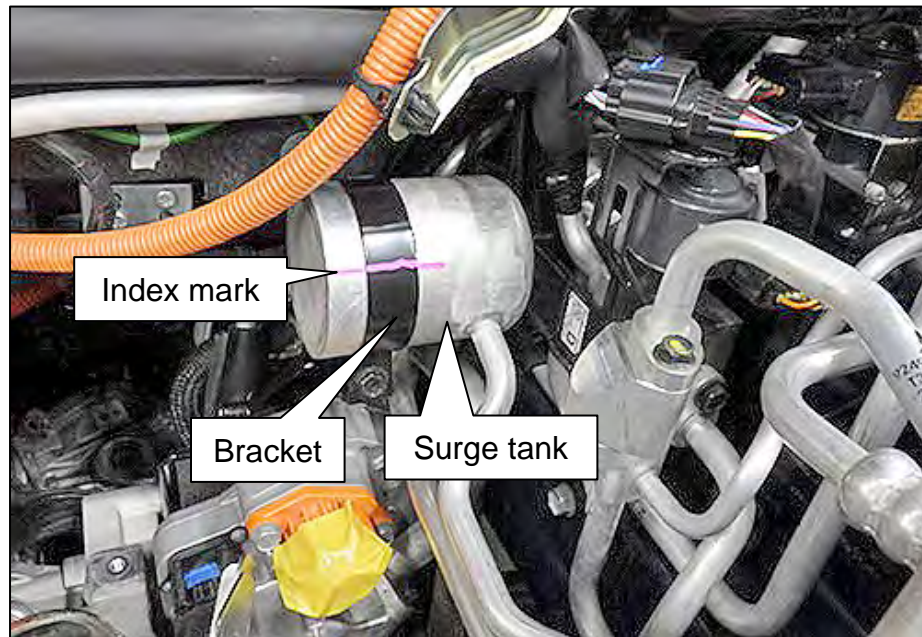

Figure 180

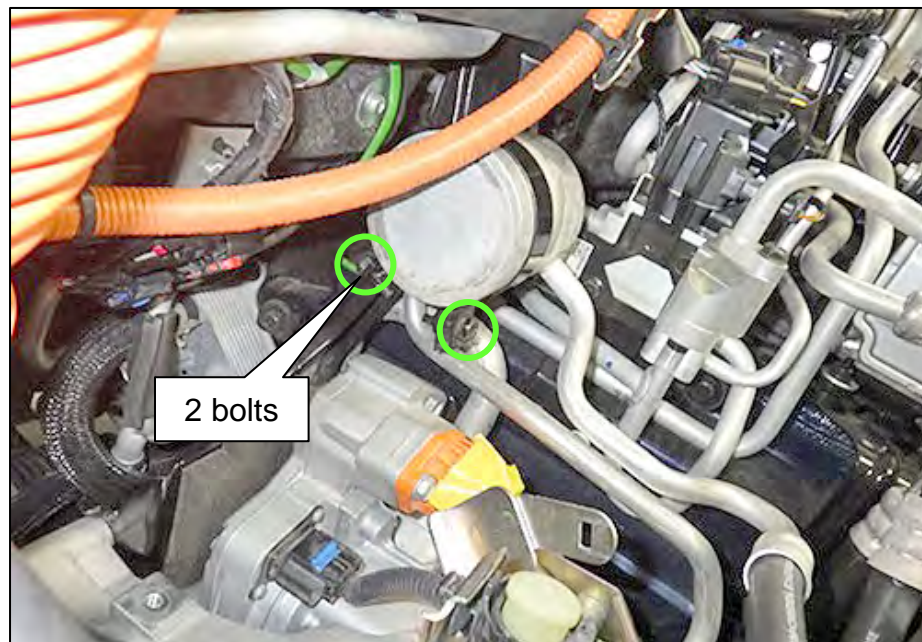

Figure 181



212. Remove the retention strap that is securing the High Voltage Harness to the vehicle.

213. Attach the wiring harness clip to its bracket.



Figure 182

214. Attach the wiring harness bracket shown in Figure 183.

- One (1) bolt.
- Torque bolt to 8 N•m (0.8 kg-m, **71 in.-lbs**).

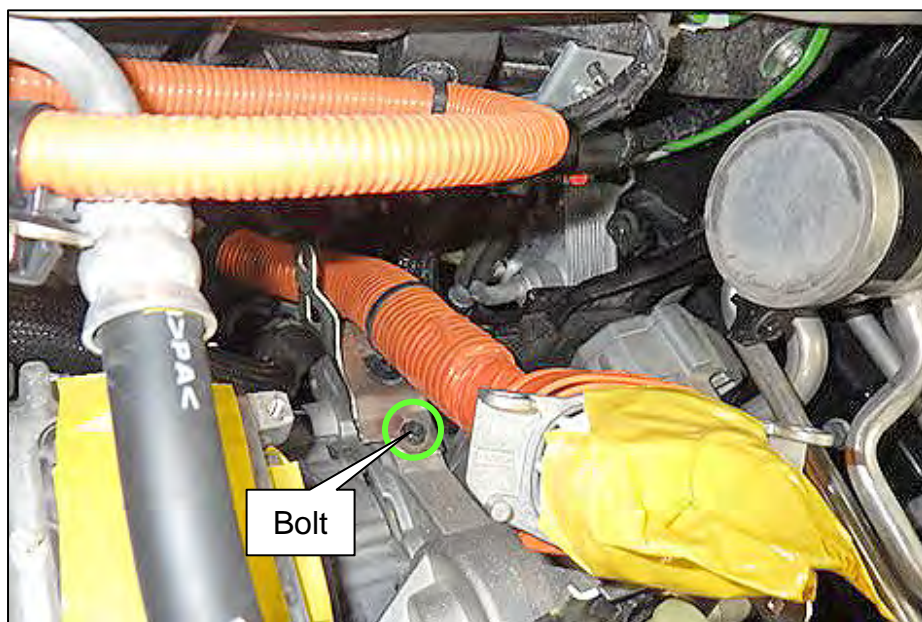

Figure 183

215. Remove the protective tape from the Inverter and High Voltage Harnesses.

216. Attach the Rear High Voltage Harness to the Inverter.

- Four (4) bolts.
- Torque bolts to 8 N•m (0.8 kg-m, **71 in.-lbs**).

**CAUTION**

To prevent personal injury or vehicle damage, high voltage buss bar and terminal connection bolts must not be cross-threaded and must be torqued to the specified value.



Figure 184

217. Attach the bottom Front High Voltage Harness connector to the Inverter.



Figure 185



218. Connect the Electric Compressor wiring harness connector.

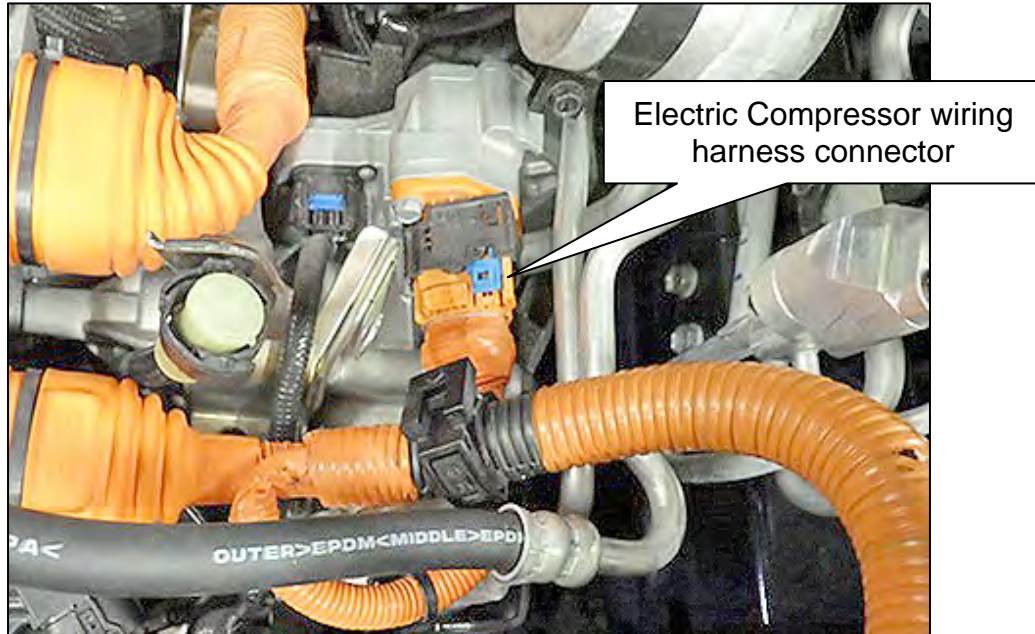

Figure 186

219. Attach the Front High Voltage Harness to the Inverter.

- Four (4) bolts.
- Torque bolts to 8 N•m (0.8 kg-m, **71 in.-lbs**).

**⚠ CAUTION**

To prevent personal injury or vehicle damage, high voltage buss bar and terminal connection bolts must not be cross-threaded and must be torqued to the specified value.

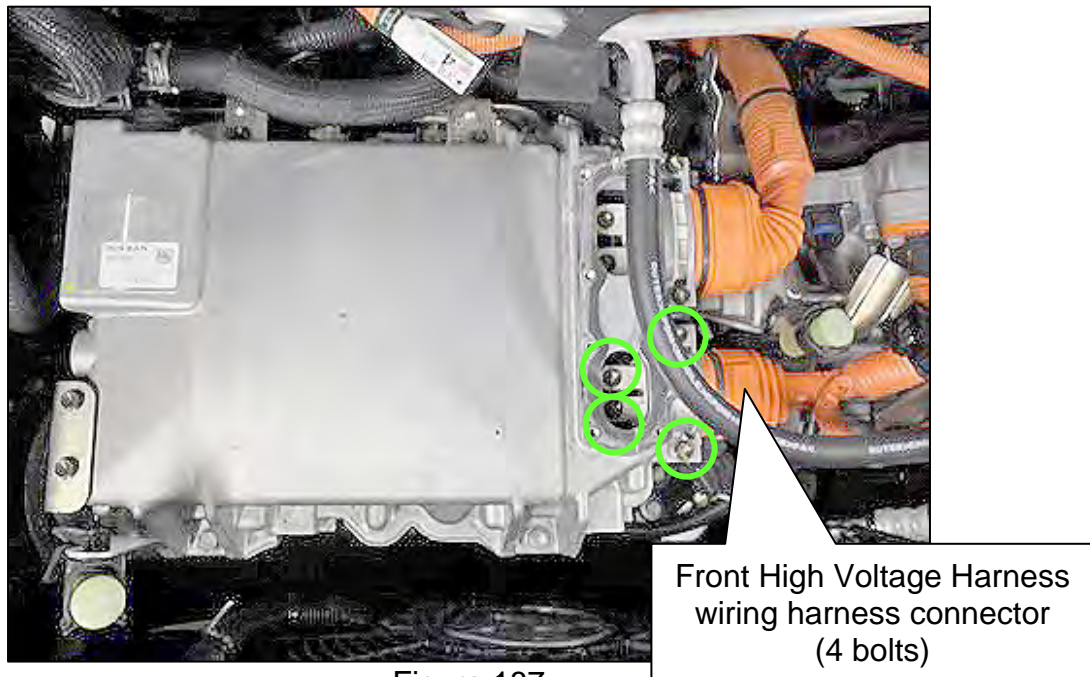

Figure 187

220. Attach the two (2) related wiring harness clips.

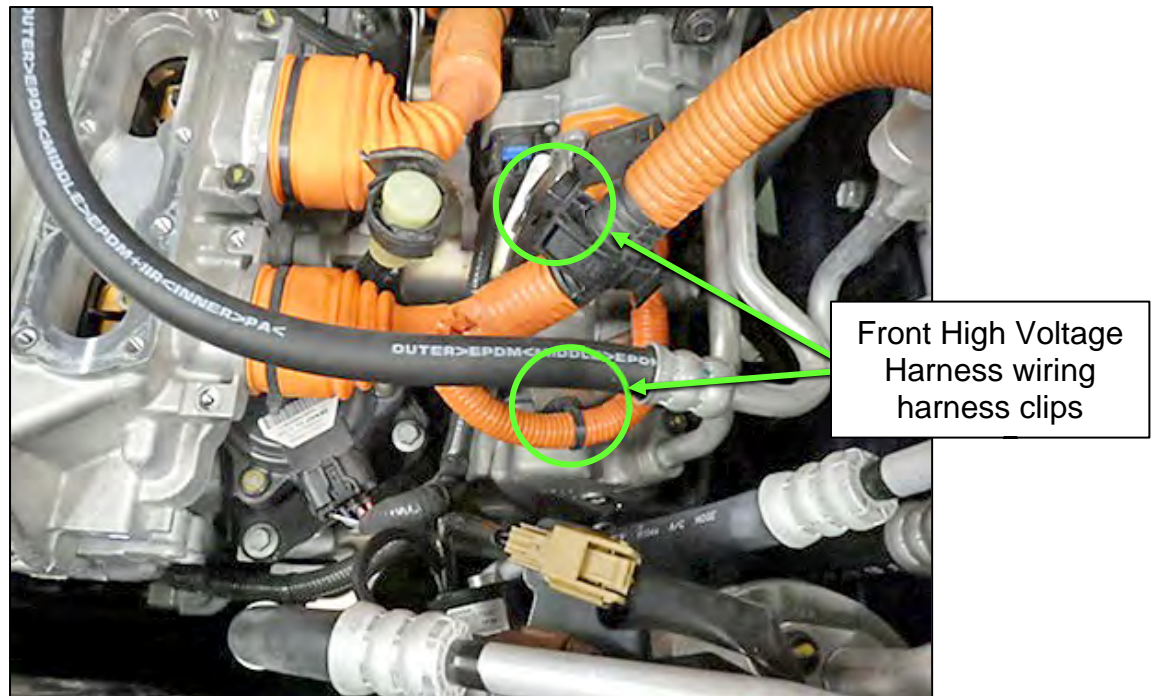

Figure 188

221. Install a new gasket for the Inverter to High Voltage Harness Cover.

- See **PARTS INFORMATION** on page 110.



Figure 189



222. Install the High Voltage Harness Cover to the Inverter.

- Eight (8) bolts.
- Torque bolts to 8 N•m (0.8 kg-m, 71 in.-lbs).

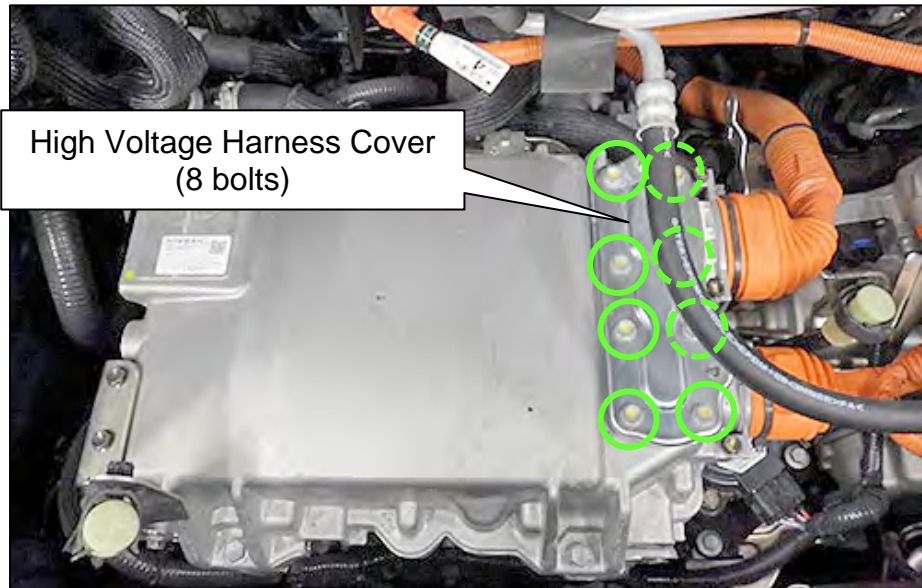

Figure 190

223. Install the High Voltage Power Delivery Assembly.

- Refer to the **ESM: ELECTRIC POWER TRAIN > VEHICLE CHARGING SYSTEM > REMOVAL AND INSTALLATION > HIGH VOLTAGE POWER DELIVERY ASSEMBLY > HIGH VOLTAGE POWER DELIVERY ASSEMBLY : Removal & Installation**

224. On the passenger (RH) side hub position a large pry bar between the wheel studs and the floor.

- Temporarily install the wheel lug nuts to protect the wheel studs.

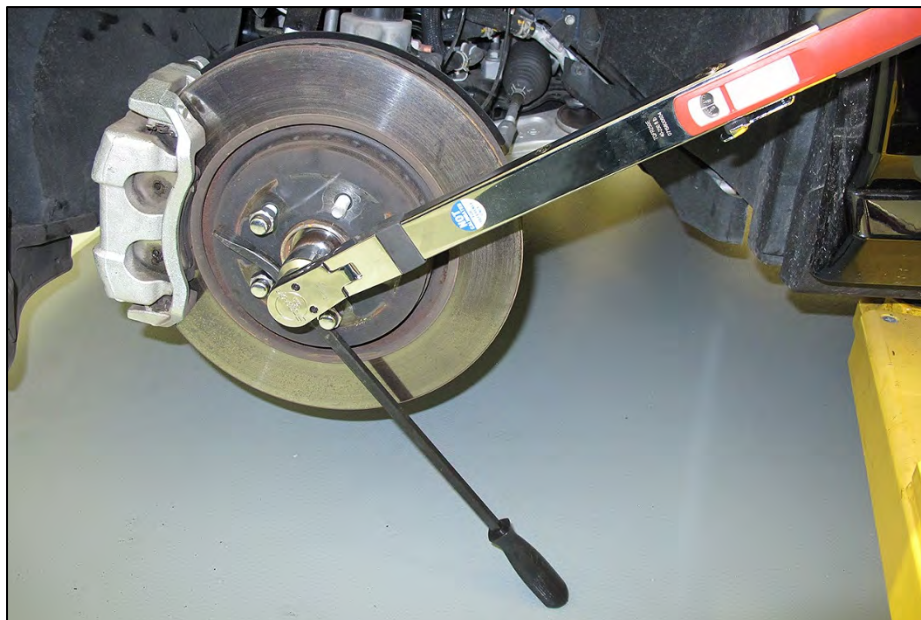

Figure 191

225. Install a new Front Drive Shaft Lock Nut and tighten to the specified torque.

- Torque nut to 217.5 N•m (22.2 kg-m, **160 ft-lb**).

226. Use a lock nut crimping punch (special tool: KV 40108700 or equivalent) to crimp the Front Drive Shaft Lock Nut.

- Crimp the wheel lock nut within the following range.
  - A: 6.2 mm
  - B: 26.4 -27.8 mm

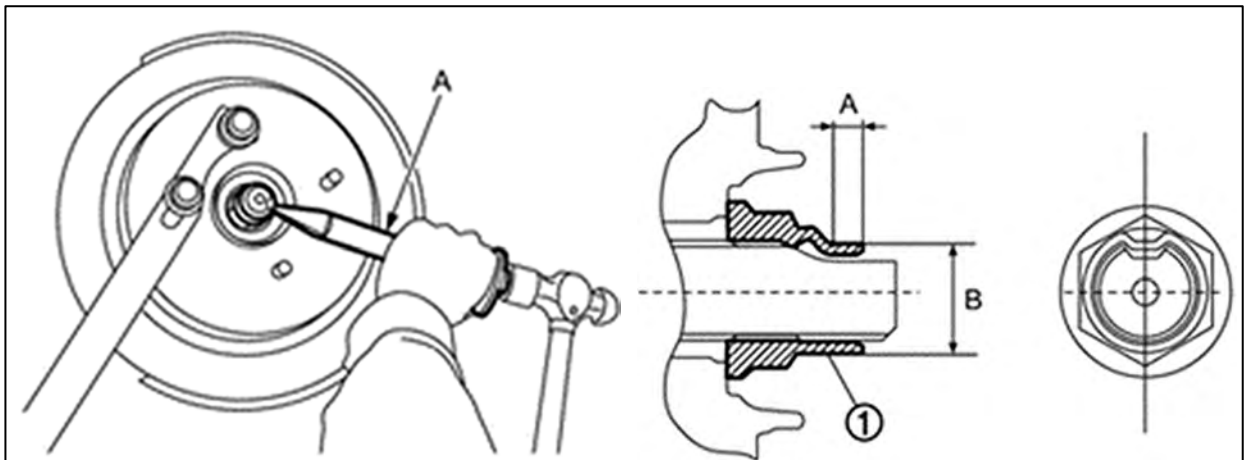

Figure 192

227. Repeat steps 224-226 on the driver (LH) side hub.

228. Install both front wheel and tire assemblies.

- Torque the wheels nuts to:
  - 19 inch wheel: 112.6 N•m (11.5 kg-m, **83 ft-lb**).
  - 20 inch wheel: 108 N•m (11.0 kg-m, **80 ft-lb**).



229. Align the lower steering joint markings as shown in Figure 193, and then install and tighten a new bolt to the specified torque.

- Refer to **PARTS INFORMATION** on page 110.
- Torque bolt to 62 N•m (6.3 kg-m, **46 ft-lb**).

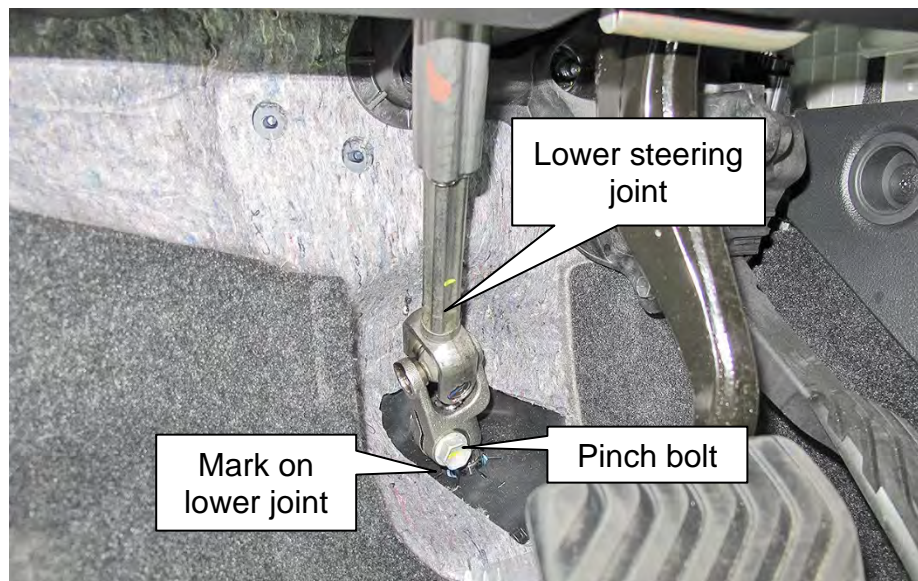

Figure 193

230. Install the Steering Shaft Lower Cover.



Figure 194

231. Remove the device that is holding the steering wheel.

## High Voltage Circuit Connection

### **DANGER**

Since hybrid vehicles and electric vehicles contain a high voltage battery, there is the risk of electric shock, electric leakage, or similar accidents if the high voltage component and vehicle are handled incorrectly. To avoid death be sure to follow the correct work procedures when performing inspection and maintenance.

### **CAUTION**

Never bring the vehicle into the READY status with the Service Plug removed unless otherwise instructed in the Service Manual. A malfunction may occur if this is not observed. Never remove plug and gasket of front traction motor. If they are removed by mistake, replace the gasket with a new one and install them.

232. Reconnect the High Voltage Service Plug.

- Refer to the ESM: **GENERAL INFORMATION > GENERAL INFORMATION > PRECAUTIONS > CAUTIONS AS TO HIGH VOLTAGE > PROCEDURE FOR CONNECTING HIGH VOLTAGE**

### **WARNING**

Touching high voltage components without using the appropriate protective equipment will cause electrocution. Wear insulating protective equipment and wait at least 10 minutes after removing the Service Plug before starting the next task.



233. Reinstall the vehicle's 12 volt battery.

- Refer to the **ESM: ELECTRICAL & POWER CONTROL > POWER SUPPLY, GROUND & CIRCUIT ELEMENTS > REMOVAL AND INSTALLATION > 12V BATTERY > Removal & Installation**

234. Clear the lift and reinstall the vehicle's front lifting point covers (Figure 196).

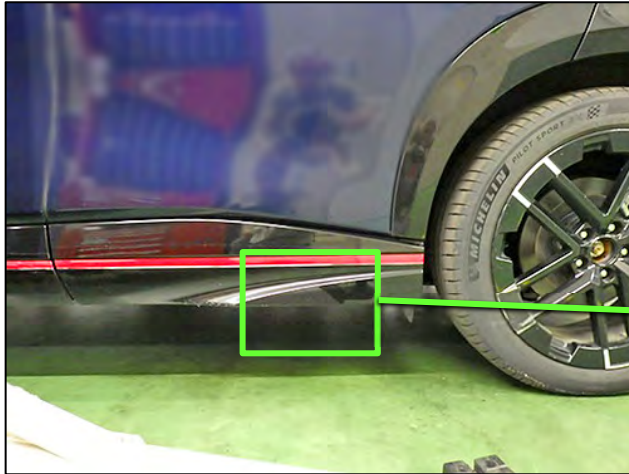

Figure 195

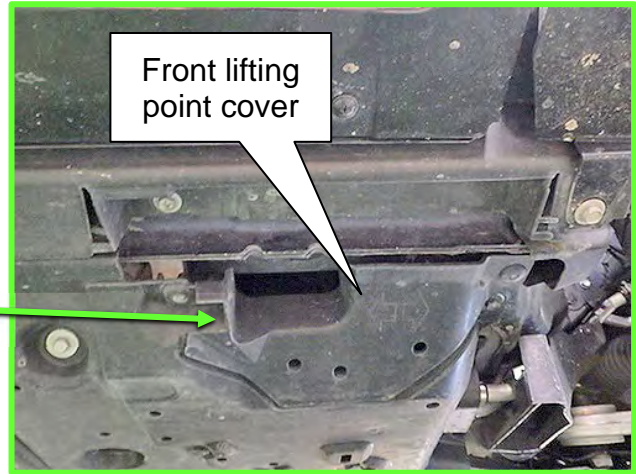

Figure 196

### Coolant Refill and CONSULT Operation

235. Using coolant refill tool NI-45695-A (or equivalent), refill the powertrain cooling system and HV battery cooling system (Figure 197).



Figure 197

236. Connect a suitable battery maintainer/smart charger to the vehicle's 12 volt battery.
237. Connect VI3 to the vehicle and press the vehicle's power switch one time without depressing the brake pedal (NOT ready mode).
238. Open CONSULT 4 on the CONSULT PC, and then login.

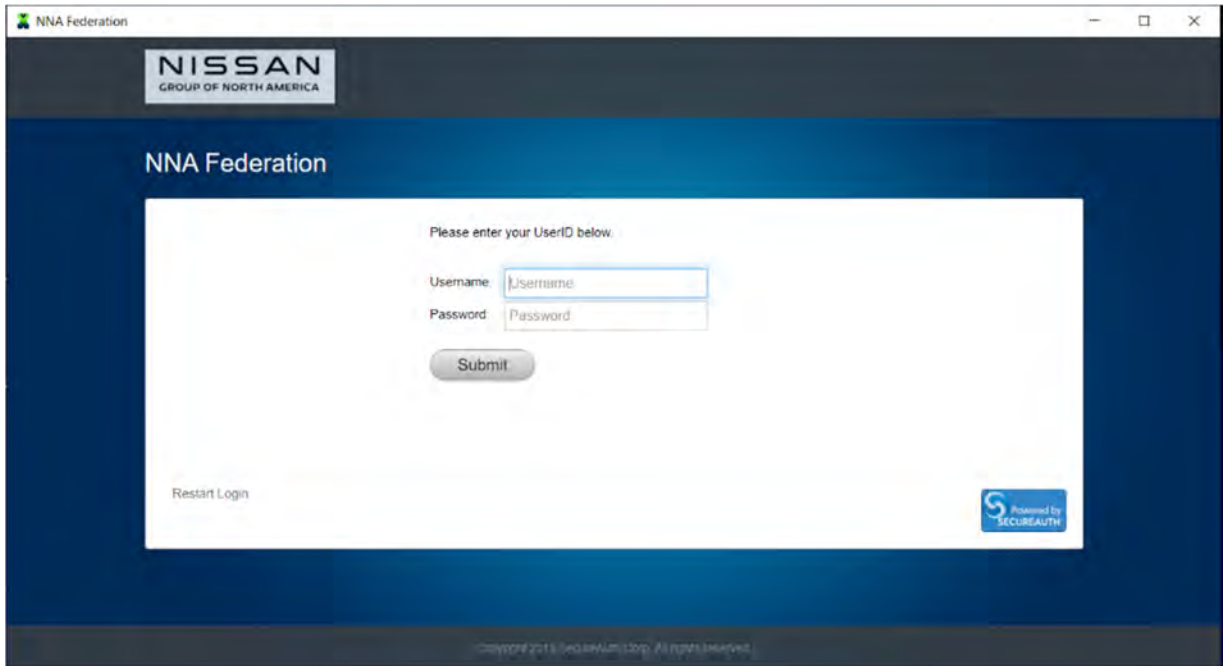

Figure 198

239. Allow system call to complete (Figure 199 below, and Figure 200 on page 102).

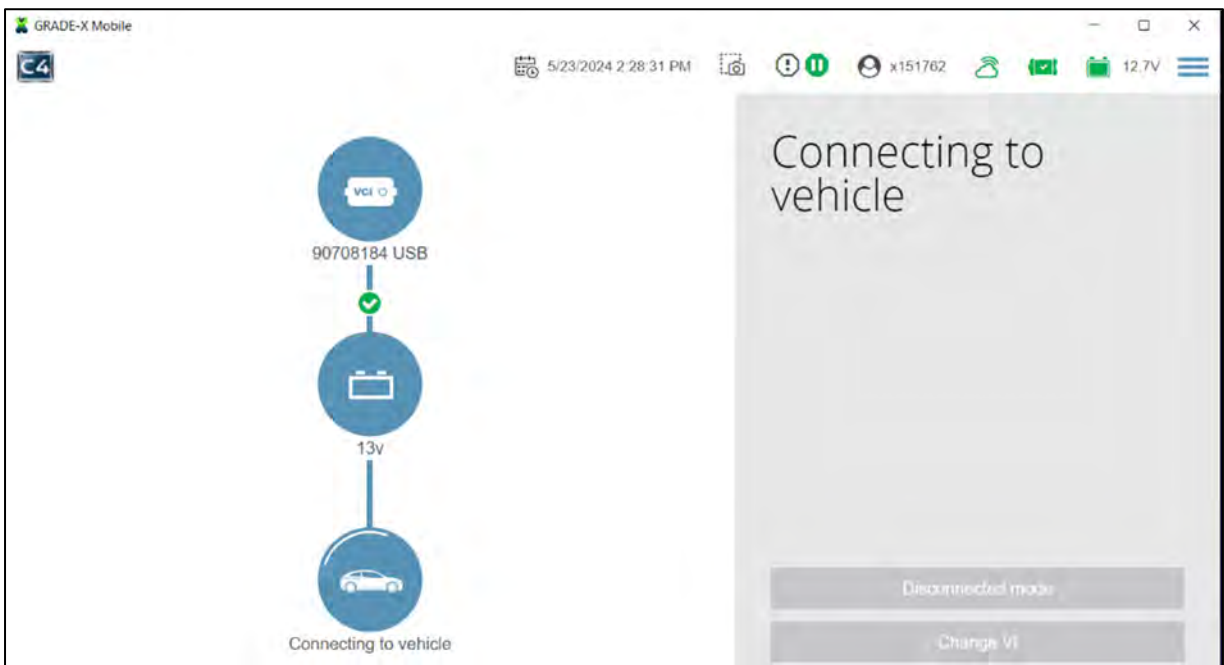

Figure 199



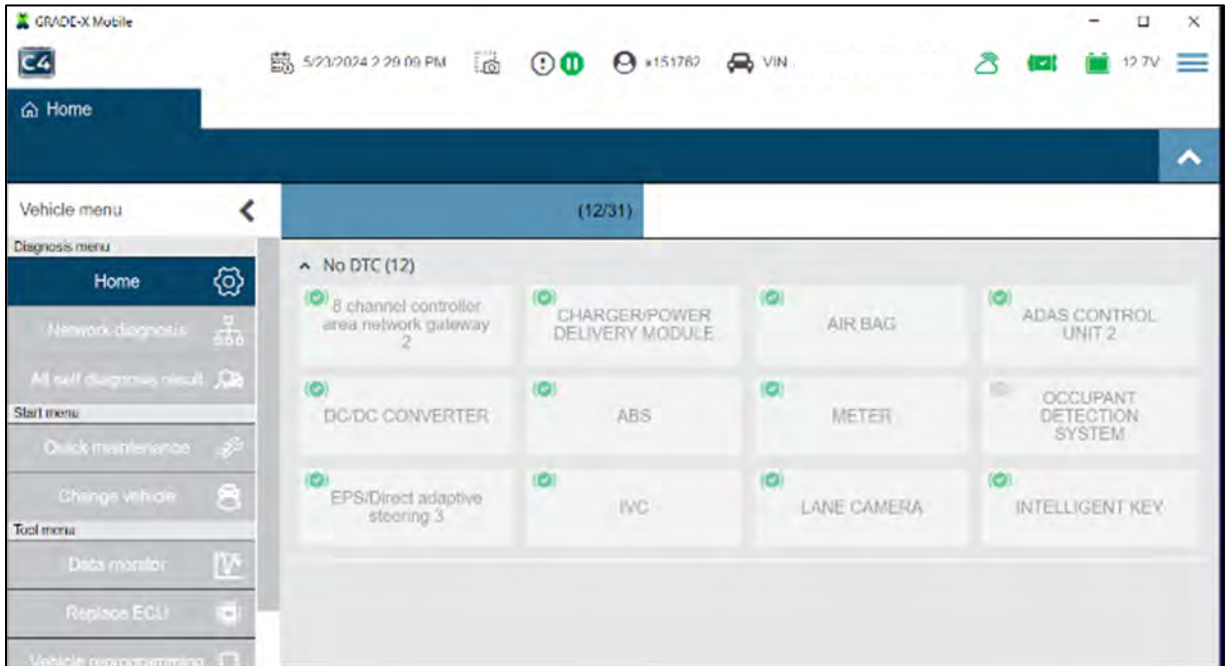

Figure 200

240. Select **VCM**.

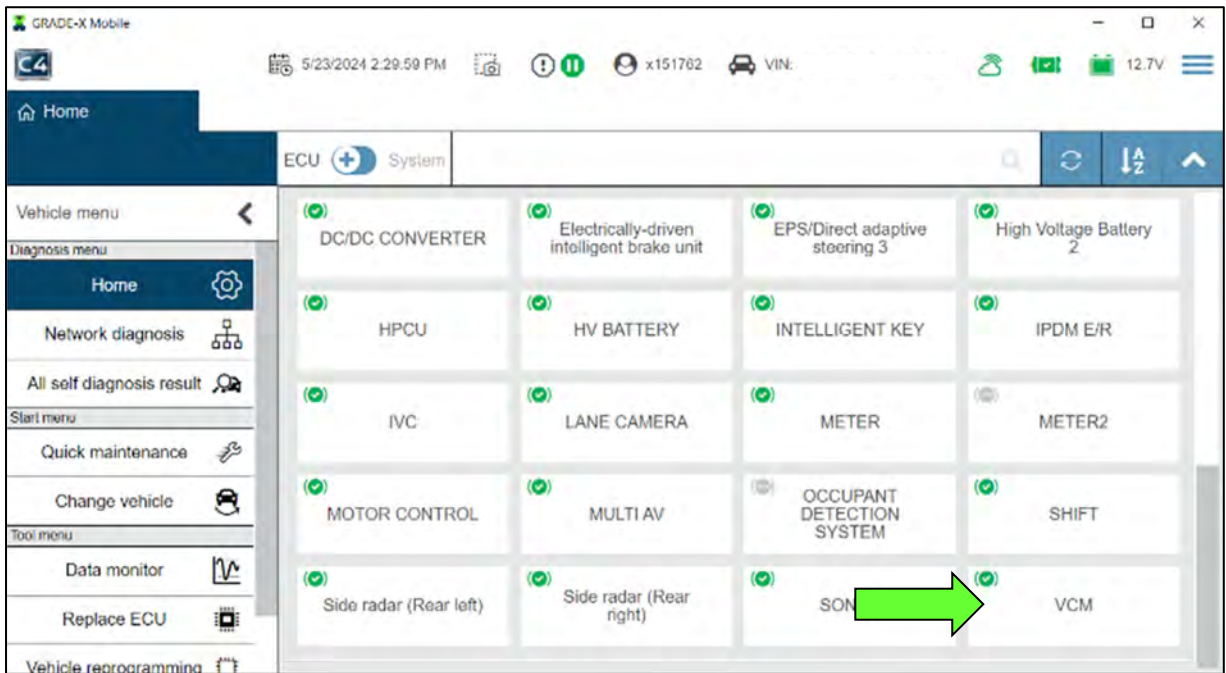

Figure 201

241. Select **Active test**.

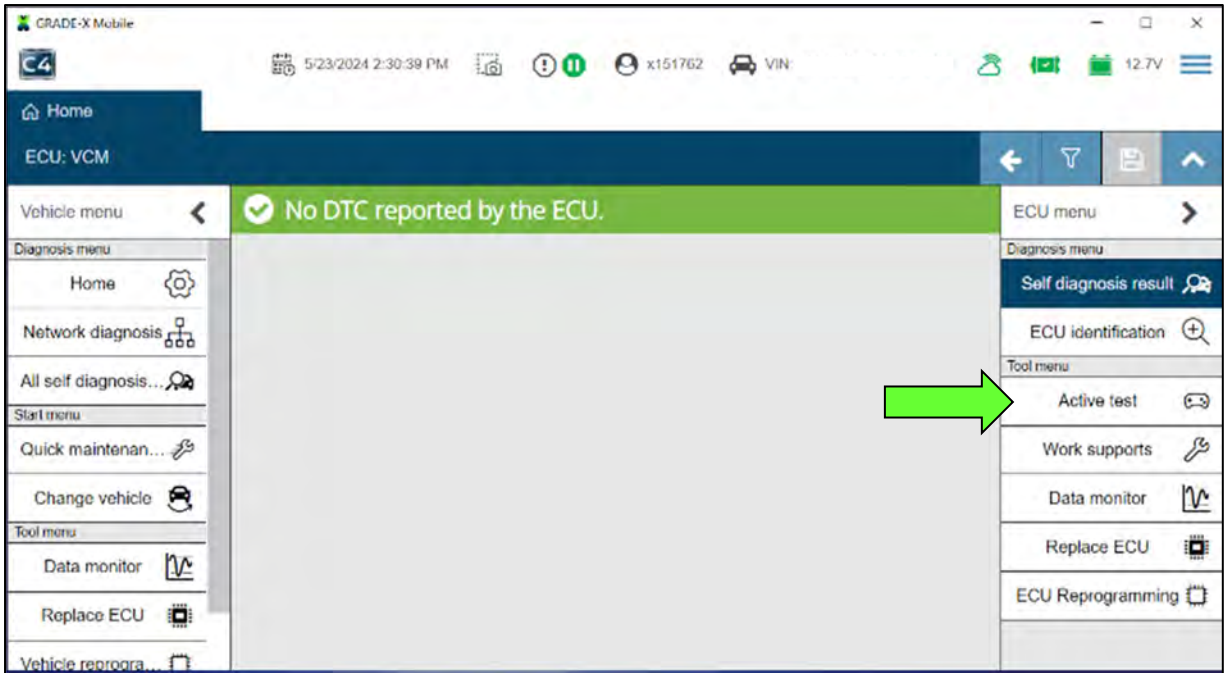

Figure 202

242. Select **ELECTRIC WATER PUMP 1**, and then select **Start**.

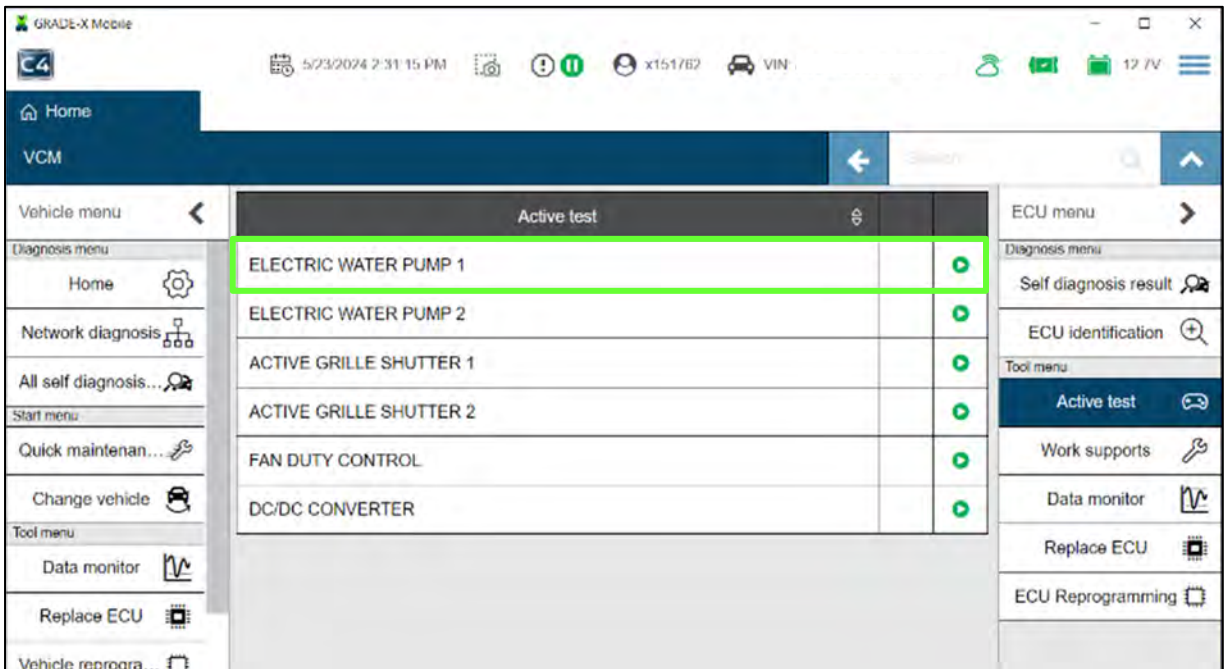

Figure 203



243. Select **Qu** to set the “Current status” to **60%**, and then run the ELECTRIC WATER PUMP 1 for 10 minutes.

- If the coolant level drops below the minimum level, stop the ELECTRIC WATER PUMP 1, fill the Coolant Reservoir to MAX level, and then continue operating the coolant pump at **60%** for 10 minutes.

**NOTICE**

Be sure to monitor and top off the coolant reservoir as the coolant level may drop when the ELECTRIC WATER PUMP 1 is activated.

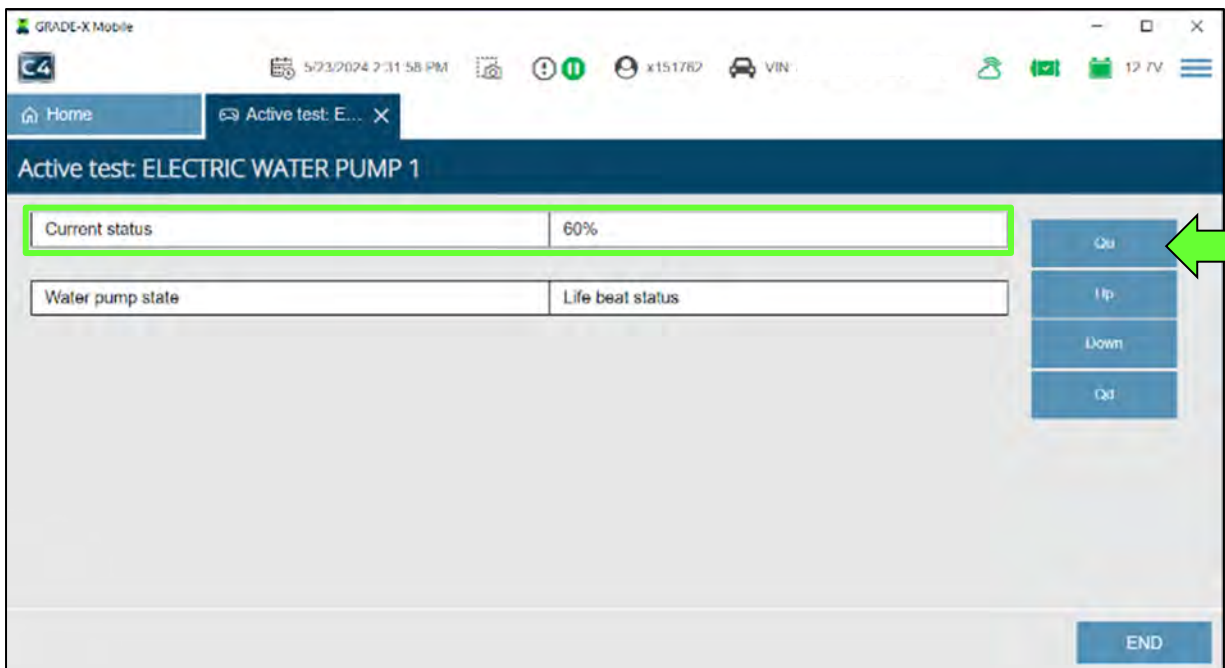

Figure 204

244. Select **Qd** to set ELECTRIC WATER PUMP 1 “Current Status” to **10%**, then select **Qu** to set “Current status” to **80%**, and allow the ELECTRIC WATER PUMP 1 to run for 10 minutes.

**NOTICE**

Be sure to monitor and top off the coolant reservoir as the coolant level may drop when the ELECTRIC WATER PUMP 1 is activated.

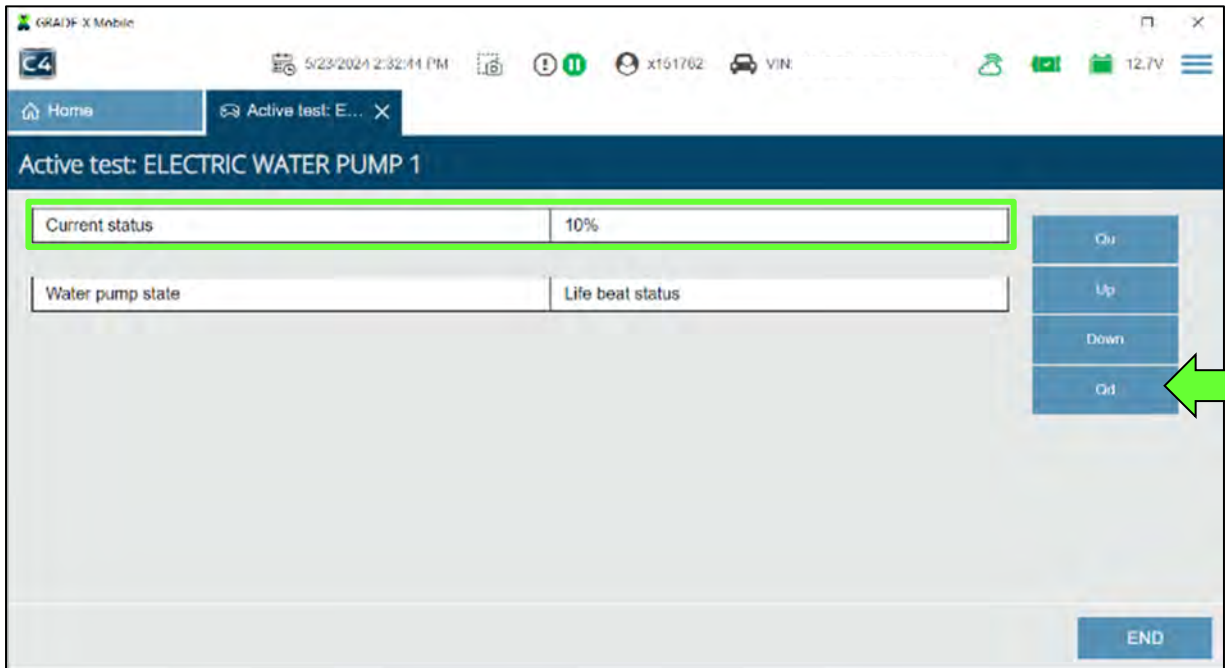

Figure 205

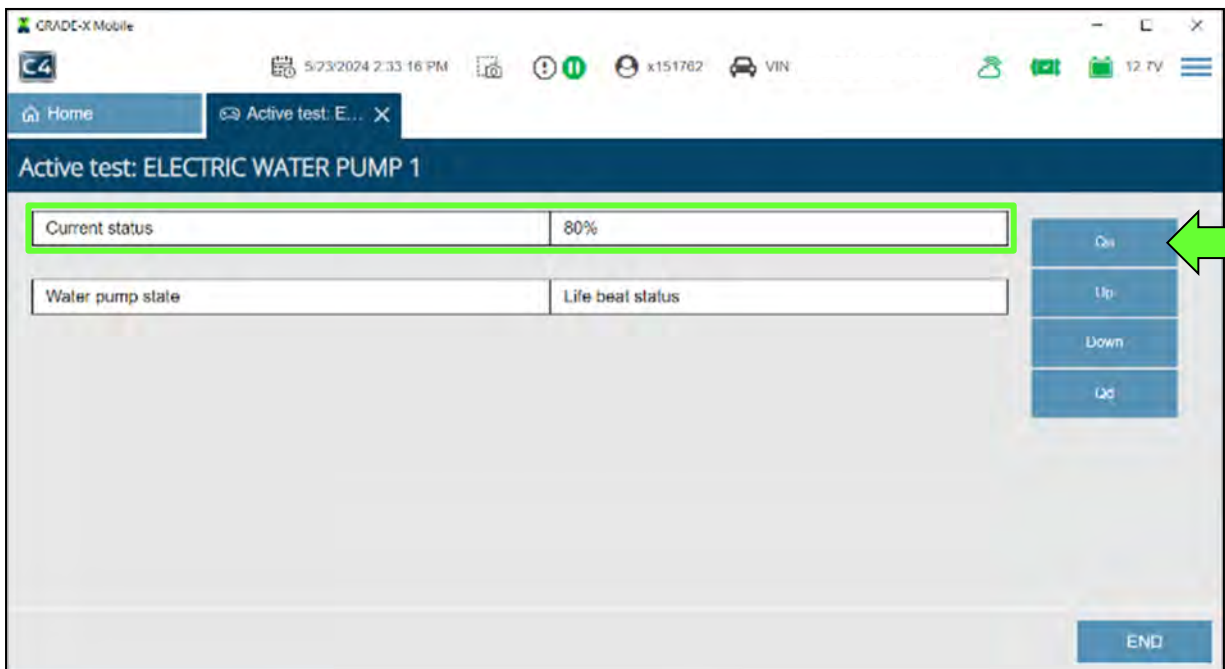

Figure 206



245. Select **Qd** to set “Current status” to **0%**, and then select **END**.

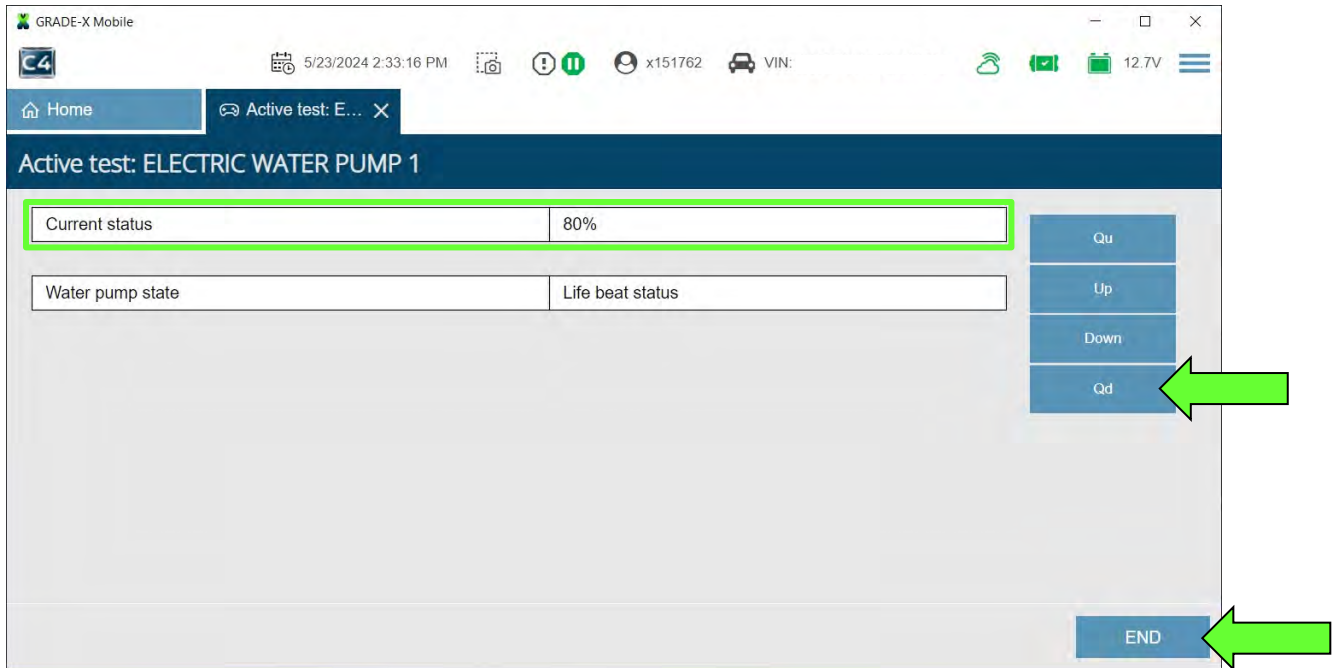

Figure 207

246. Select **Home** > **Active test** > **ELECTRIC WATER PUMP 2**, repeat steps 243-245, and then proceed to step 247.

247. Select **Home**.

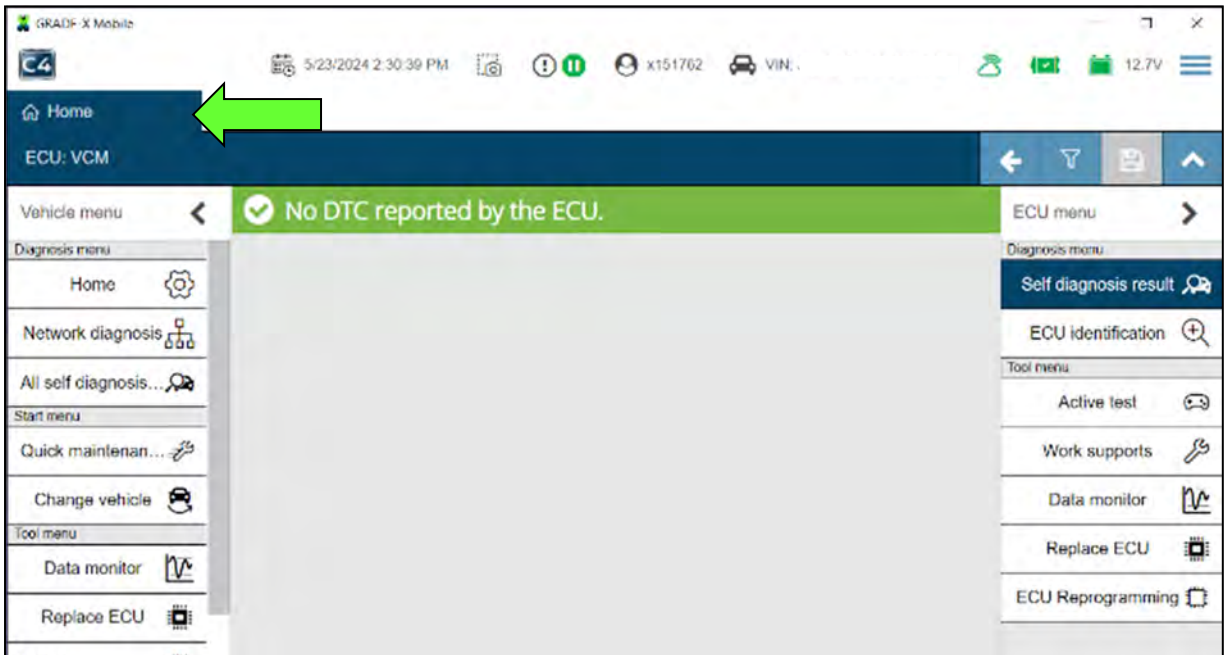

Figure 208

## Write Resolver Correction Value and Rotor Resistance Value

248. Select **MOTOR CONTROL**.

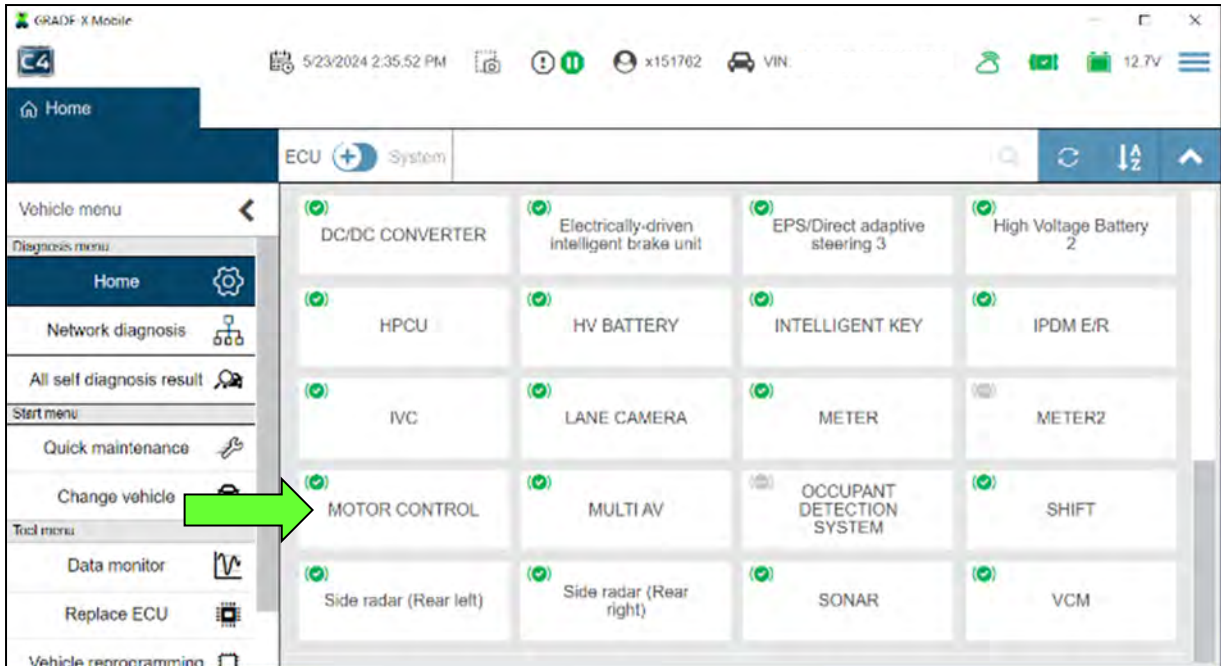

Figure 209

249. Select **Work Supports**.

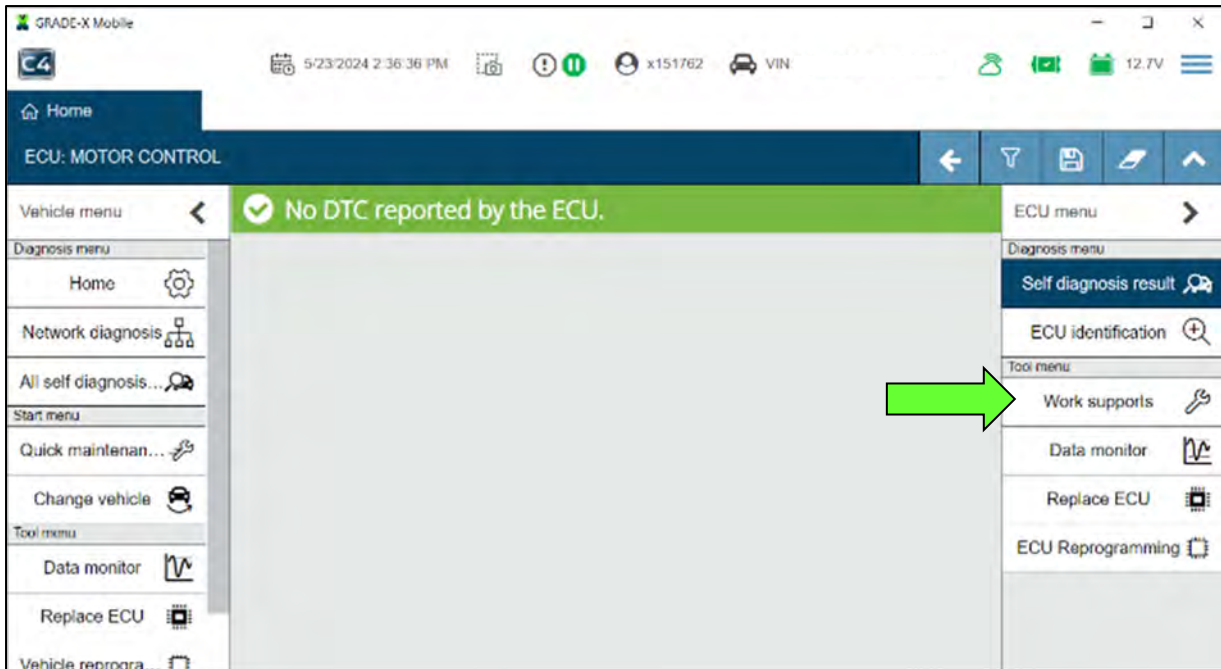

Figure 210



250. Select **Writing Resolver Offset Value and Rotor Resistance Value**.

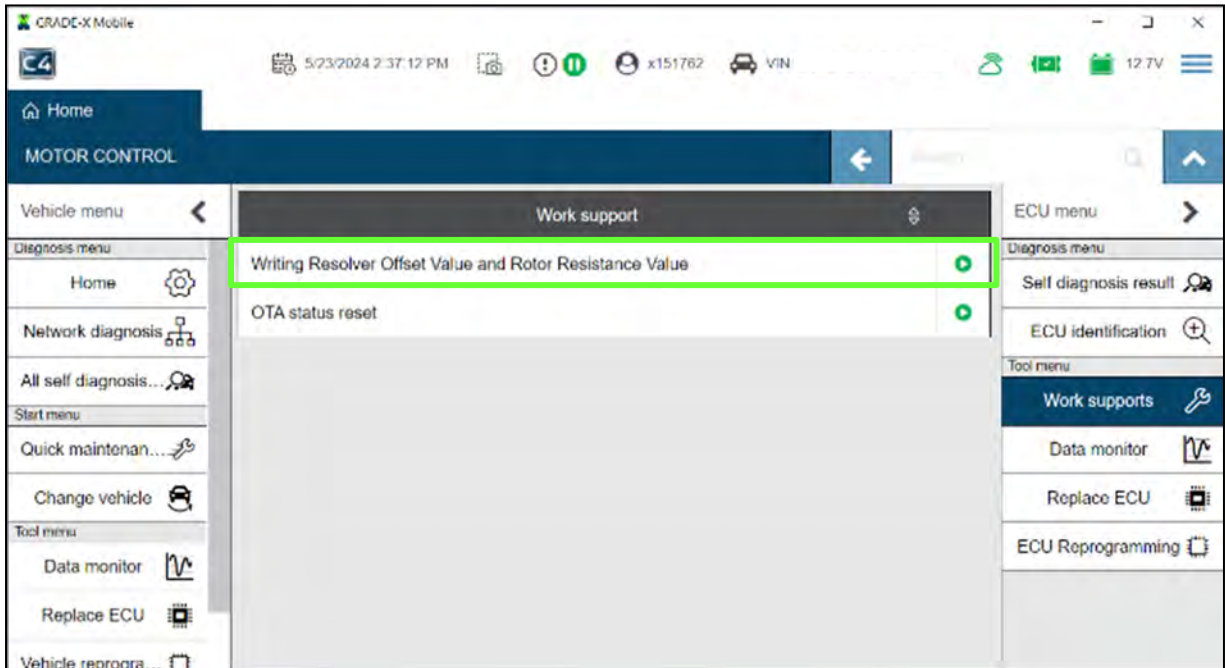

Figure 211

251. Enter the “Resolver offset value” and “Rotor resistance value” that were written on the repair order in step 149 on page 65.

252. Select **Write**.

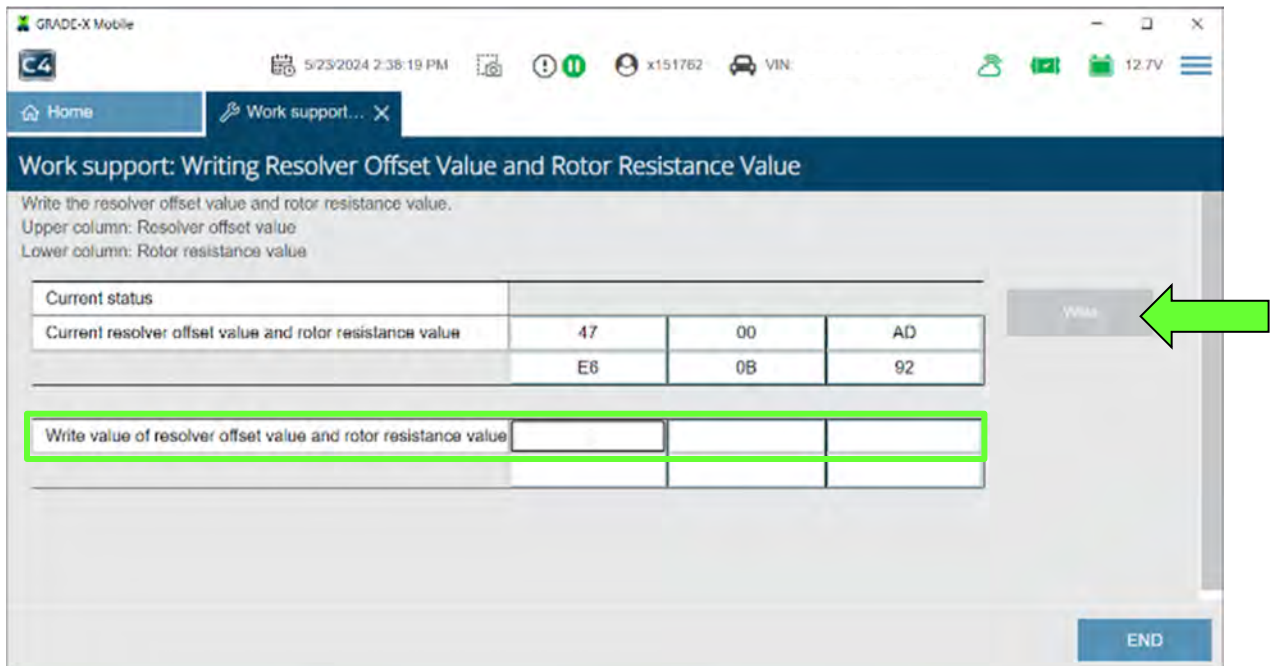

Figure 212

253. Confirm that "Write completed" is displayed.

**HINT:** If "Write completed" is not displayed, repeat steps 251 and 252 on page 108.

254. Turn OFF the vehicle's power switch.

255. Turn ON the vehicle's power switch and wait for at least 2 seconds.

256. Confirm that it is switched to the correction value entered in "Writing Resolver Correction Value and Rotor Resistance Value".

257. Select **END**.

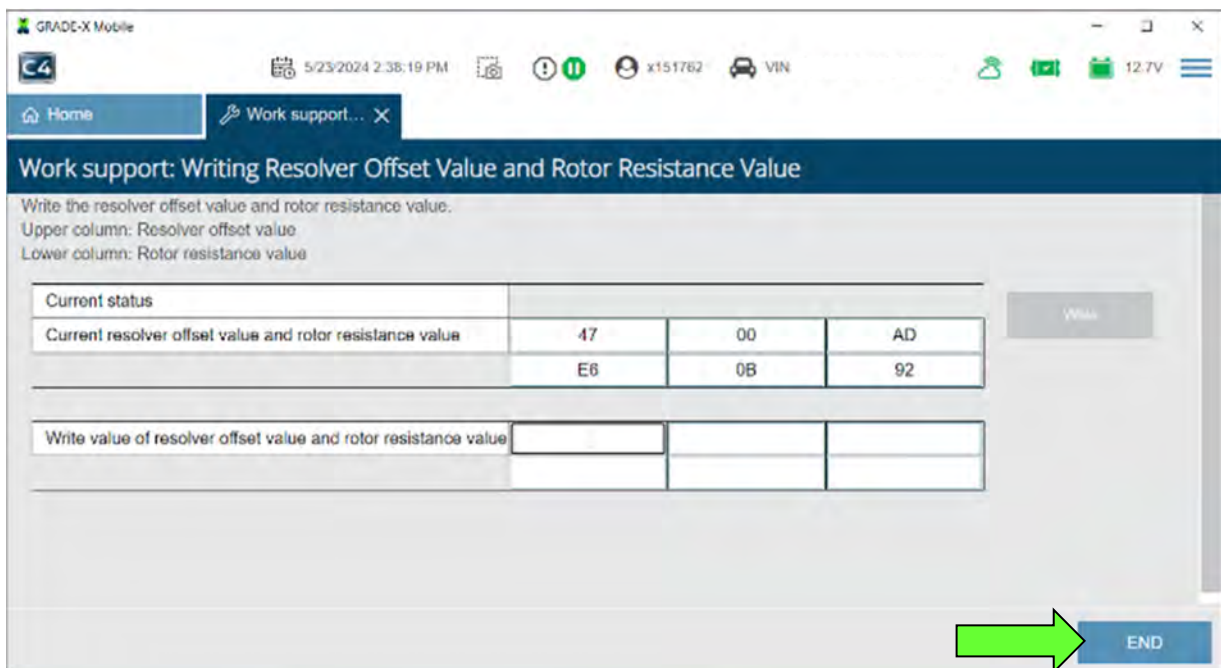

Figure 213

258. Perform Inspection after installation of the Front Suspension Member.

- Refer to the ESM: **SUSPENSION > FRONT SUSPENSION > REMOVAL AND INSTALLATION > FRONT SUSPENSION MEMBER > FRONT SUSPENSION MEMBER > Inspection**
  - Check Wheel speed sensor connections.
  - Perform alignment.
  - Perform steering angle sensor adjustment.



## PARTS INFORMATION

DESCRIPTION	PART NUMBER	QUANTITY
MOTOR ASSY-TRACTION	B90A0-5MP0F	1
HOSE-BREATHER	17335-00Q0B	1
GASKET (Red, upper)	290H9-0634R	1
GASKET (Black, bottom)	290H9-4362R	1
SEAL-O RING	290X6-5239R	1
GASKET (High voltage supply unit bus bar cover)	294J8-7519R	1
SEAL-POWER HEAD INVERTER	XBGA1-5MP0A	1
PACKING-DRAIN COCK (Electric pump cooling drain plug O-ring)	21481-89900	1
BOLT (Steering column shaft)	01125-A1051	1
NUT-LOCK,FRONT WHEEL BEARING	40262-4GA0D	2
NUT-LOCK,FRONT WHEEL BEARING	40262-6RA1A	2
Seal-0-Ring	92472-3NF0B	2
Seal-0-Ring	92474-3NF0B	2
NUT	01223-A2031	2
NUT	01225-A2011	2
NUT	54588-EN00A	4

## CLAIMS INFORMATION

Submit a "CM" line claim using the following claims coding:

CAMPAIGN ("CM") ID	DESCRIPTION	OP CODE	FRT
R24A3	Replace Traction Motor 2WD	R24A30	10.5

## AMENDMENT HISTORY

PUBLISHED DATE	REFERENCE	DESCRIPTION
June 20, 2024	NTB24-027	Original bulletin published