

RECALL 24V324 / 2024-266 REMEDY INSTRUCTIONS

	Make(s): MANY, SEE BELOW Model(s): MANY, SEE BELOW Model Year(s): 2024	Repair Code: Allotted Time: Inspection Code: Allotted Time:
	Concern: GO-ES Space Save Foldaway Seat: The seat back may not support an FMVSS 210 shoulder belt load when it is in the fully reclined position.	Photo(s) Required: N/A Prior Authorization Required: N/A Part(s) Kit Number: N/A Part(s) Return: N/A

Place vehicle in (P) Park and engage the Parking Brake. Disconnect the vehicles' battery Positive and Negative. Block any tires/wheels to prevent the vehicle from rolling. Failure to do so may result in electrocution, fire or other personal injury, property damage and/or death.

CERTAIN 2024: GLAVAL UNIVERSAL – G9074 & G9082
 CERTAIN 2024: MOBILITY TRANS SAFETBUS – MTR3XC, MTU4XE, MTW3XC & MTX2CG
 CERTAIN 2024: SENATOR II - ST93083, ST93084, ST93112, ST93135 & ST93211
 CERTAIN 2024: SENATOR II HD – ST93163
 CERTAIN 2024: STARCRAFT ALLSTAR – ST93102

**PLEASE REFERENCE THE INCLUDED INSTRUCTIONS BELOW FROM
 FREEDMAN SEATING**



GO-ES SpaceSaver Foldaway Service Instructions

20240130

© Freedman Seating Company. All rights reserved. Information contained in this document is indicative only. No representation or warranty is given or should be relied on that it is complete or correct or will apply to any particular project. This will depend on the technical and commercial circumstances. It is provided without liability and is subject to change without notice. Reproduction, use or disclosure to third parties, without express written authorization, is strictly prohibited.

www.freedmanseating.com



Overview

Inspection

Rework

© Freedman Seating Company. All rights reserved. Information contained in this document is indicative only. No representation or warranty is given or should be relied on that it is complete or correct or will apply to any particular project. This will depend on the technical and commercial circumstances. It is provided without liability and is subject to change without notice. Reproduction, use or disclosure to third parties, without express written authorization, is strictly prohibited.

3/21/20
24

2

Inspection Step 1

Bring seat back cushion from stowed position (seat back cushion is folded down against seat cushion) to first engagement point of the back lock (most upright position of the seat back cushion)

Add a piece of tape on the dump cover shroud so that it touches the handle

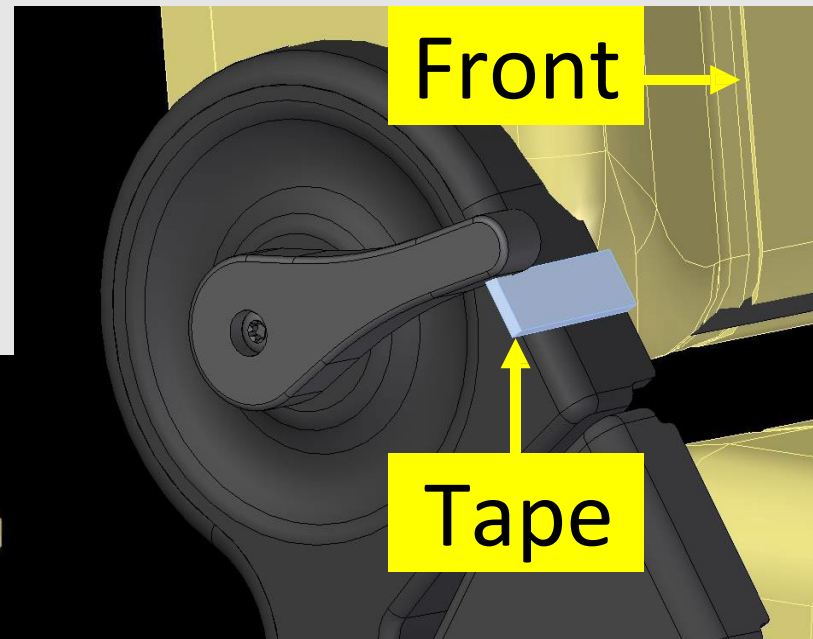
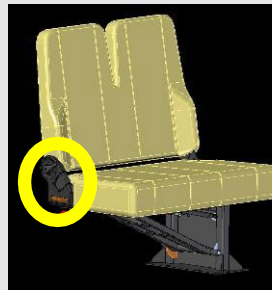

© Freedman Seating Company. All rights reserved. Information contained in this document is indicative only. No representation or warranty is given or should be relied on that it is complete or correct or will apply to any particular project. This will depend on the technical and commercial circumstances. It is provided without liability and is subject to change without notice. Reproduction, use or disclosure to third parties, without express written authorization, is strictly prohibited.

Inspection

Step 2

Pull the handle to release the seat back and actuate the back into the most reclined position

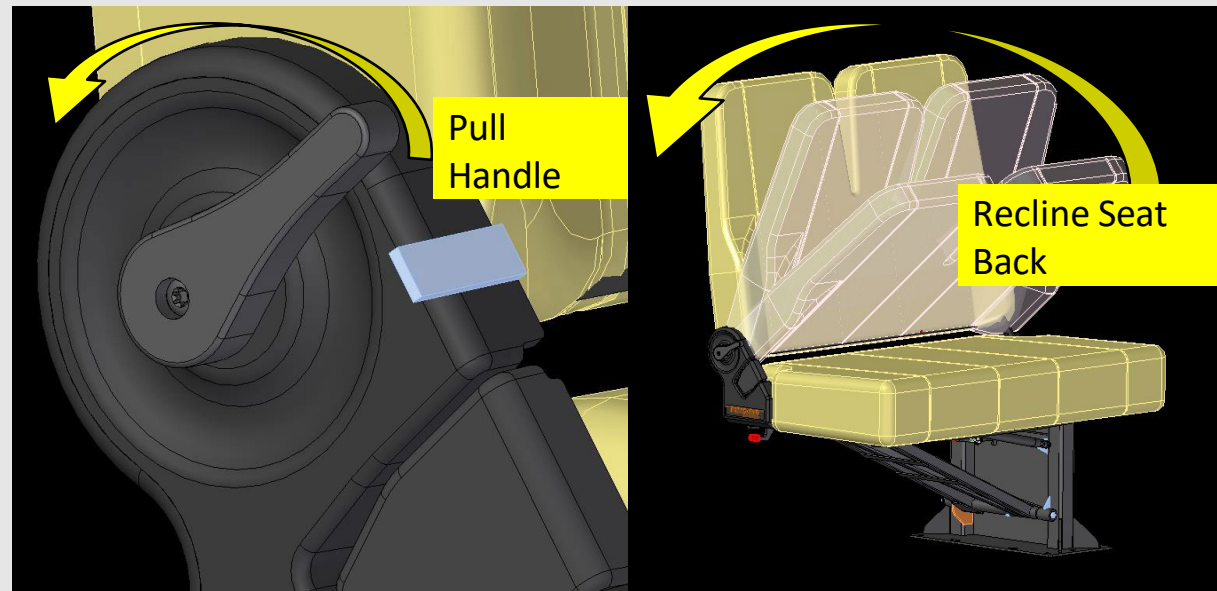

© Freedman Seating Company. All rights reserved. Information contained in this document is indicative only. No representation or warranty is given or should be relied on that it is complete or correct or will apply to any particular project. This will depend on the technical and commercial circumstances. It is provided without liability and is subject to change without notice. Reproduction, use or disclosure to third parties, without express written authorization, is strictly prohibited.

Inspection Step 3

Release handle and pull seat back forward

If handle returns back to original position, no additional work needed

If handle does not return back to the original position then seat will need to be reworked

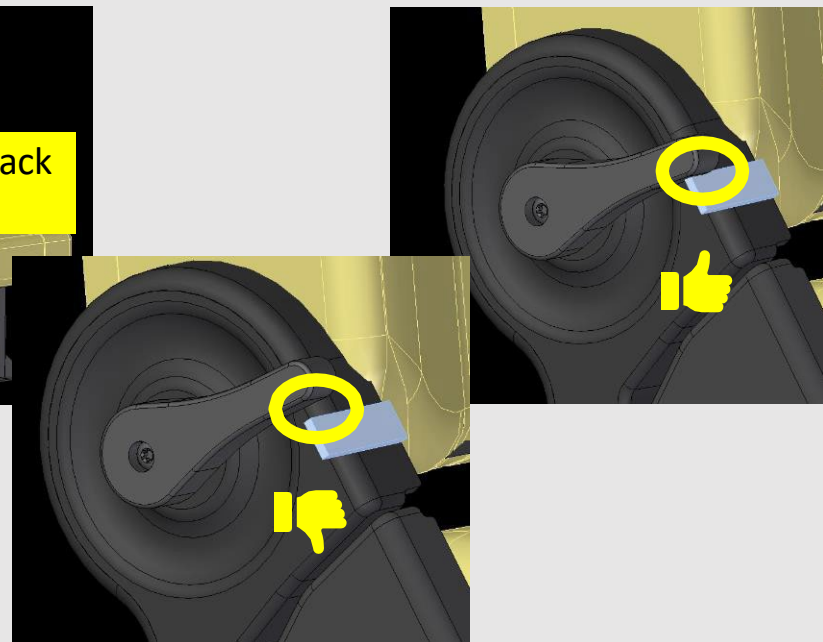
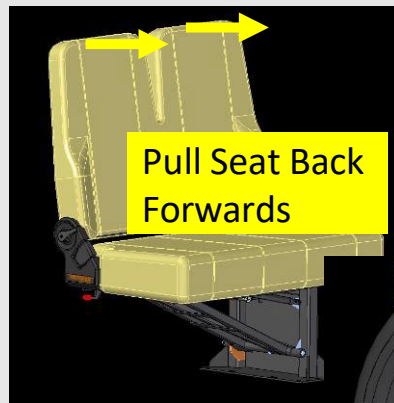

© Freedman Seating Company. All rights reserved. Information contained in this document is indicative only. No representation or warranty is given or should be relied on that it is complete or correct or will apply to any particular project. This will depend on the technical and commercial circumstances. It is provided without liability and is subject to change without notice. Reproduction, use or disclosure to third parties, without express written authorization, is strictly prohibited.

Rework Step 4

Fold the seat back down to the cushion to expose the stop brackets

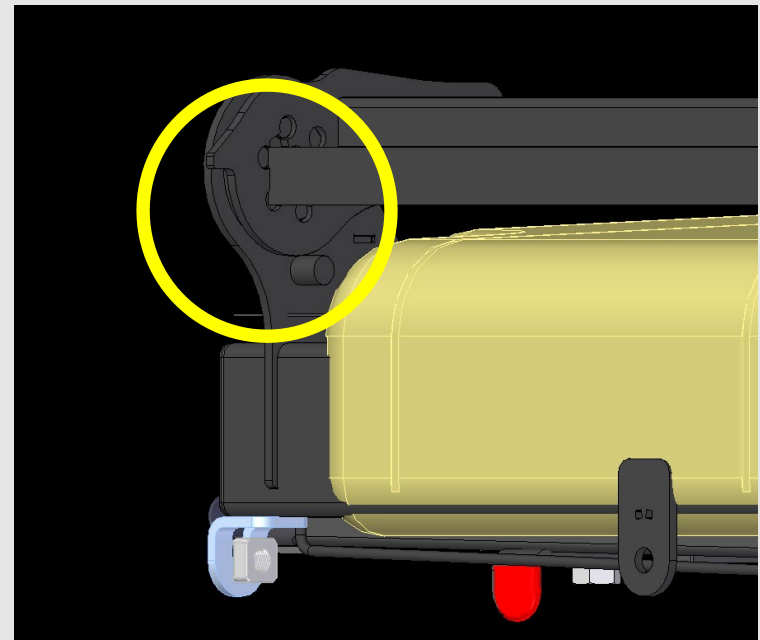

© Freedman Seating Company. All rights reserved. Information contained in this document is indicative only. No representation or warranty is given or should be relied on that it is complete or correct or will apply to any particular project. This will depend on the technical and commercial circumstances. It is provided without liability and is subject to change without notice. Reproduction, use or disclosure to third parties, without express written authorization, is strictly prohibited.

Rework Step 5

On the stop bracket adjacent to pin, use a Dynafile or similar tool to grind off up to 1/32" off of the face of the stop

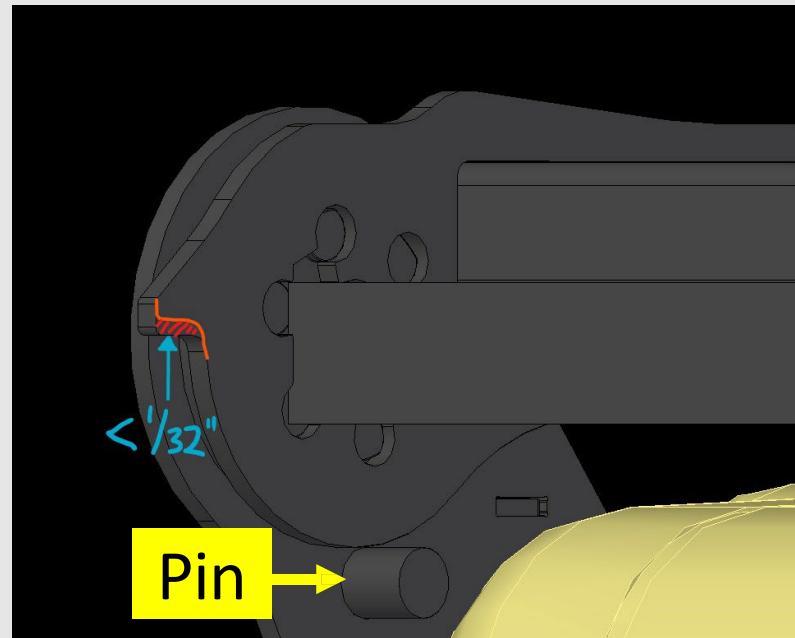

© Freedman Seating Company. All rights reserved. Information contained in this document is indicative only. No representation or warranty is given or should be relied on that it is complete or correct or will apply to any particular project. This will depend on the technical and commercial circumstances. It is provided without liability and is subject to change without notice. Reproduction, use or disclosure to third parties, without express written authorization, is strictly prohibited.

Rework and Final Inspection Step 6

Repeat step 3 to recheck handle and if necessary repeat steps 4-5 to get handle to appropriately lock

© Freedman Seating Company. All rights reserved. Information contained in this document is indicative only. No representation or warranty is given or should be relied on that it is complete or correct or will apply to any particular project. This will depend on the technical and commercial circumstances. It is provided without liability and is subject to change without notice. Reproduction, use or disclosure to third parties, without express written authorization, is strictly prohibited.



Thank you

Will O'Connor

Lead Engineer – New Product Design

(773)- 524 -2440x321 / Will.OConnor@FreedmanSeating.com

© Freedman Seating Company. All rights reserved. Information contained in this document is indicative only. No representation or warranty is given or should be relied on that it is complete or correct or will apply to any particular project. This will depend on the technical and commercial circumstances. It is provided without liability and is subject to change without notice. Reproduction, use or disclosure to third parties, without express written authorization, is strictly prohibited.

www.freedmanseating.com

